





# ASSEMBLY GUIDE

## **Easy Assembly Guide**







# Unboxing your new piano

Remove the Piano Stand and the piano from its packaging.

## Also Included in the box:

A:		X18	M4*12
B:		X2	
C:		X4	
D:		X4	M4X25
E:		X4	M66 (M6X20)

### Bench Contents:

	A:		X8
	B:		X8
	C:		X8

Piano

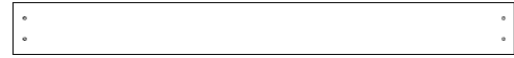
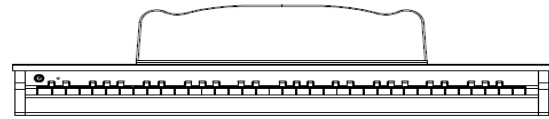

Crosspiece

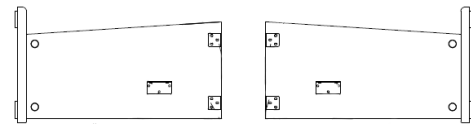

Legs (2)

*Be sure to unpack the enclosed hardware from the box and check it with the list above.*

## Piano Assembly

### Attaching the brackets:

Begin assembly by attaching the brackets to the legs as shown here.

- Attach each bracket using three (A) screws.
- Make sure that the (C) Brackets are facing the top of the leg.
- Make sure the (B) brackets are facing the front of the leg.

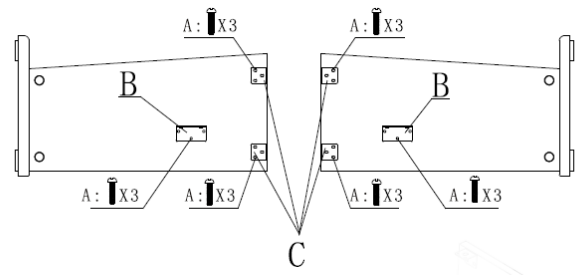

## Assembling the stand:

Begin assembling the piano by attaching the legs of the stand with the back panel:

- A. Insert 2 (D) bolts into the each side of the crosspiece.
- B. Screw bolts into the brackets on each leg, make sure that the crosspiece and the feet are all facing toward you.
- C. Tighten until the crosspiece is flush with the leg brackets, and the legs are firmly attached.

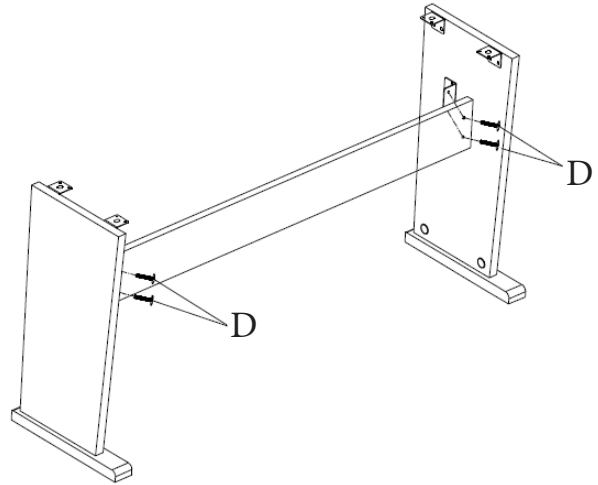

## Attaching the piano:

Attach the piano body to the stand using four (E) bolts

- A. Rest the piano on the stand and line up the hole in the bottom of the piano with the holes in the brackets on the leg.
- B. Make sure that the piano and legs are facing the same way.
- C. Tighten (E) bolts into each hole until the piano sits flush on the legs and is firmly attached.

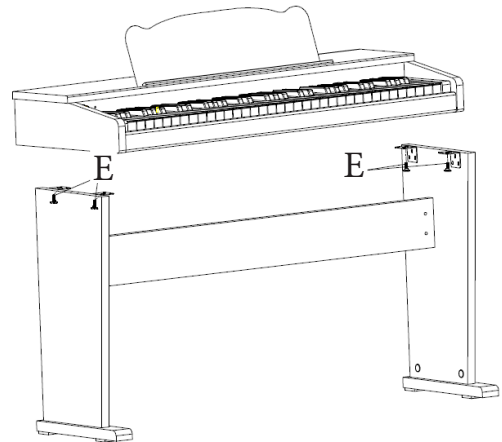

## Assembling the bench:

The bench is assembled using kernel locking joiners.

A. Insert a kernel screw into the four holes in the bottom of the seat, and two center holes in each leg. Tighten with a screwdriver.

B. Insert a locking nut into each hole in the back panel. Insert the two screws from each leg and tighten the locking nut to secure.

C. Repeat step B to attach seat.

D. Finish assembly by covering the locking nuts with plastic covers (C)

