

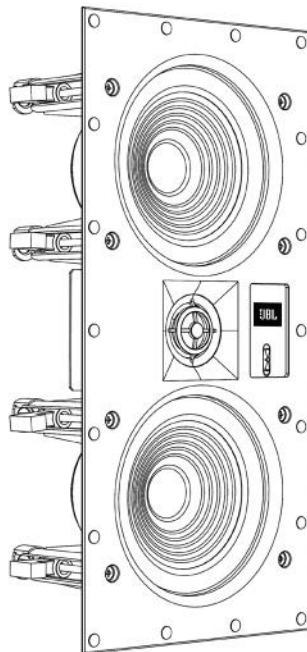

STUDIO 2 6IW, STUDIO 2 8IW, STUDIO 2 55IW
In-Wall Architectural Loudspeaker
Instruction Manual

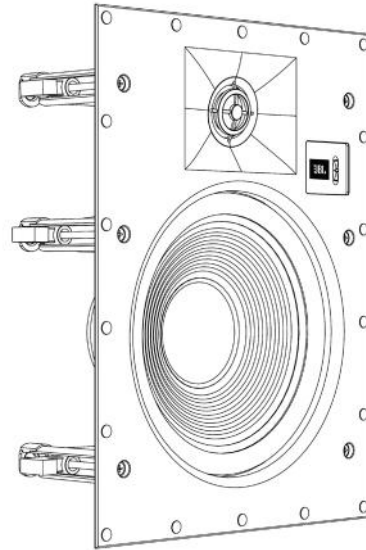
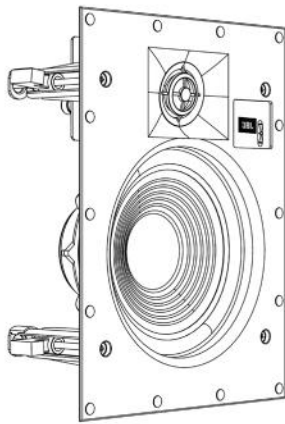

DOCUMENTATION CONVENTIONS

This document contains general safety, installation and operation instructions for the JBL STUDIO 2 6IW, 8IW and 55IW in-wall loudspeakers. It is important to read this document before attempting to use this product. Pay particular attention to:

WARNING: Calls attention to a procedure, practice, condition or the like that, if not correctly performed or adhered to, could result in injury or death.

CAUTION: Calls attention to a procedure, practice, condition or the like that, if not correctly performed or adhered to, could result in damage to or destruction of part of or the entire product.

Note: Calls attention to information that aids in the installation or operation of the product.

ABOUT JBL® IN-WALL SPEAKERS

For more than 68 years, JBL® engineers have been involved in every aspect of music and film recording and reproduction, from live performances to the recordings you play on-the-go and in your home, car or office. We're confident that the JBL system you have chosen will provide every note of enjoyment you expect – and that when you think about purchasing additional audio equipment, you will once again choose JBL products.

IN-WALL LOUDSPEAKER HIGHLIGHTS

- Long-throw woofers with rubber surrounds provide high output with low distortion.
- 1-inch (25mm) CMMD Lite tweeter with an integrated waveguide provides optimized response both on and off axis.
- High-order crossover network delivers accurate timbre reproduction.

PRODUCT REGISTRATION

Please take a moment to register your product on our Web site at www.jbl.com. You'll enable us to keep you posted on our latest advancements and help us to understand our customers and build products that meet their needs and expectations.

BOX CONTENTS

Your JBL in-wall loudspeaker box should contain the following items:

- 1 x JBL in-wall loudspeaker
- 1 x grille
- 1 x extra scrim cloth for grille
- 1 x mounting template
- 1 x instruction manual

UNPACKING THE SPEAKER

Carefully unpack the speaker. If you suspect damage from transit, report it immediately to your dealer and/or delivery service. Keep the shipping carton and packing materials for future use.

INSTALLATION CONSIDERATIONS

Your new JBL loudspeakers have been engineered to provide extremely accurate performance. However, any speaker's ultimate performance will be affected by the speaker's placement in the listening room and the acoustics of the room. Not all listening spaces can accommodate the ideal conditions of these two factors. Therefore, careful attention to the placement of your JBL in-wall loudspeakers will have a significant impact on the general performance of the loudspeakers.

LOUDSPEAKER PLACEMENT FOR DISTRIBUTED SOUND

- Since distributed sound is general sound throughout an area, place the loudspeakers as uniformly as possible for even sound coverage throughout the area.
- Place the left and right loudspeakers roughly the same distance from the primary listener locations.
- To avoid “hot spots” where the sound is too loud, plan to use more loudspeakers, with each set to play at a lower volume.

LOUDSPEAKER PLACEMENT FOR TWO-CHANNEL STEREO

Place the left and right loudspeakers the same distance from the primary listening area (or as close to the same distance as possible). The distance from each speaker to its nearest side wall should also be as close to the same distance as possible.

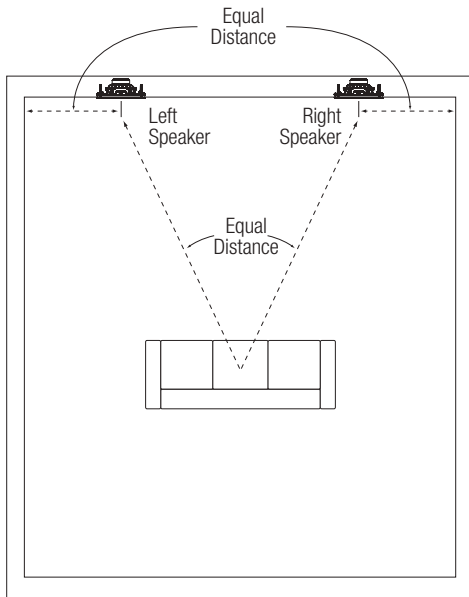

Ideally, the distance between the left and right loudspeakers should be slightly less than their distance from the primary listening area.

LOUDSPEAKER PLACEMENT FOR HOME THEATER

The front left and front right loudspeakers should be located on either side of the video display, with their tweeters as close to ear level as possible.

- The front left and front right loudspeakers should be relatively close to the sides of the video display. For example, front left and front right loudspeakers used with a 50-in (1.3m) video display should generally not be more than 80 in (2m) apart.
- The center loudspeaker should be aligned with the center of the video display. Its tweeter should be no more than 2 ft (0.6m) above or below the tweeters of the front left and front right speakers.
- The JBL HDI waveguide will maintain even sound dispersion and a high-performance listening experience even when the front in-wall loudspeakers are installed above ear-level. This permits more flexible speaker placement during installation.

5.1-Channel Speaker Placement

- In a 5.1-channel system, the surround left and surround right loudspeakers should be located to the sides of the main listening area, 5 ft – 7 ft (1.5m – 2.1m) from the floor.

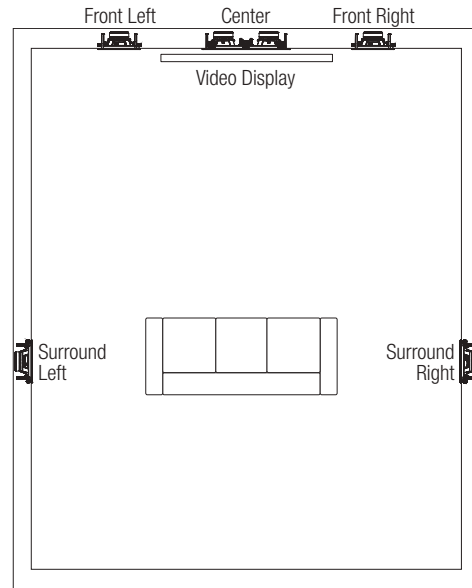

7.1-Channel Speaker Placement

- In a 7.1-channel system, the surround left and surround right loudspeakers should be located directly to the sides of the main listening area, 5 ft – 7 ft (1.5m – 2.1m) from the floor.
- In a 7.1-channel system, the surround back left and surround back right loudspeakers should be located on the rear wall, 3 ft – 6 ft (0.9m – 1.8m) apart and at 5 ft – 7 ft (1.5m – 2.1m) from the floor.

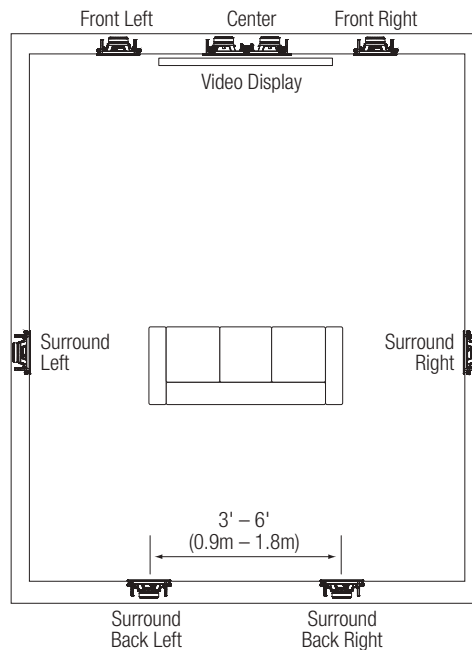

INSTALLATION INSTRUCTIONS

JBL architectural speakers are extremely easy to install. However, if you are unable to understand and follow the instructions in this manual clearly and fully, or if you are unsure of your ability to install these loudspeakers properly, please contact your dealer or a qualified installer.

WARNING: HARMAN International assumes no responsibility for improper installation of hardware or for any personal injuries or product damages resulting from improper installation or a fallen loudspeaker.

CONNECTING TO THE AMPLIFIER

CAUTION: REMOVE POWER

You must connect the speaker wires before the speaker is fully installed. To protect the audio system and yourself from damage or injury through accidental electrical shorting and surges during installation, turn all audio system power OFF before beginning the speaker installation.

Speaker Wire

Use high-quality speaker wire to obtain the best performance from your JBL in-wall speakers.

- For wire lengths of less than 50 ft (15m), use at least 16-gauge speaker wire.
- For wire lengths between 50 ft and 100 ft (15m – 30m), use at least 12-gauge speaker wire.
- For wire lengths of greater than 100 ft (30m), use at least 10-gauge speaker wire.

Note: All speaker wires must comply with all local building and safety codes for use in in-wall applications.

Making Connections

Connect each channel's positive (+) terminal on the back of the amplifier or receiver to the positive (red) terminal on the corresponding speaker; connect each channel's negative (–) terminal on the back of the amplifier or receiver to the negative (black) terminal on the corresponding speaker. Do not reverse polarities (that is, do not connect + to –, or – to +) when making connections. Doing so will cause poor imaging and diminished bass response.

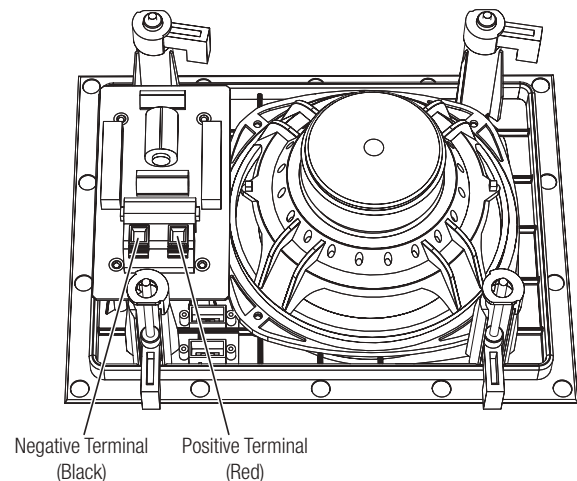

Press down on the post to open the hole; insert the bare end of the wire into the hole and release the post to secure the wire.

CAUTION: To avoid short circuits that may damage your equipment, be certain that positive and negative wire strands do not touch each other and do not touch metal parts such as the speaker frame.

MOUNTING THE SPEAKERS

For New Construction

If you wish to pre-install a rough-in frame for the speakers before the drywall is installed in new construction, you will need to purchase the correct rough-in frame kit for your loudspeaker model from your authorized JBL dealer. Detailed mounting instructions are supplied with the rough-in kit. After the drywall is installed, follow the installation instructions in *For Existing Construction*, below.

For Existing Construction

Note: The installation procedure is the same for all models covered by this manual.

1. Ensure that the drywall, plywood or other wall material is 1/2" – 2" (13mm – 51mm) thick and capable of withstanding the weight of the speaker being installed.

Make sure to allow at least 1" (25.4mm) between the edge of the supplied installation template and any rafters or other obstructions behind the wall, so the speaker's locking mechanism will have room to engage fully. Perform an obstruction survey to be sure that there are no studs, lengths of conduit, pipes, heating ducts or air returns in the wall cavity that will interfere with the speaker.

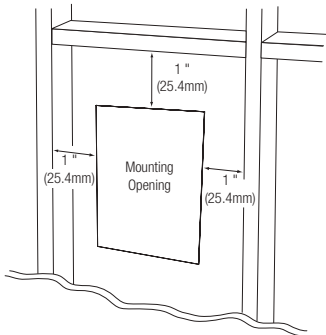

2. Determine the correct speaker location and use the template included with the speaker to mark the wall material.

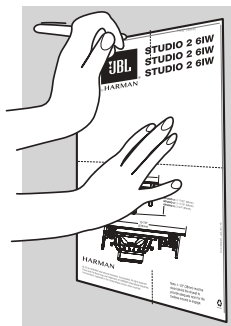

3. Cut the drywall along the mark you made in Step 2 to create the mounting opening.

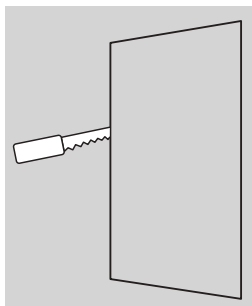

4. Connect the speaker to the amplifier as explained in *Connecting to the Amplifier*, on page 4.

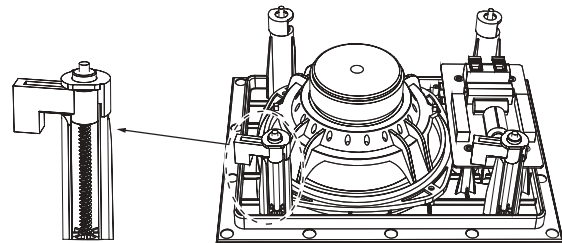
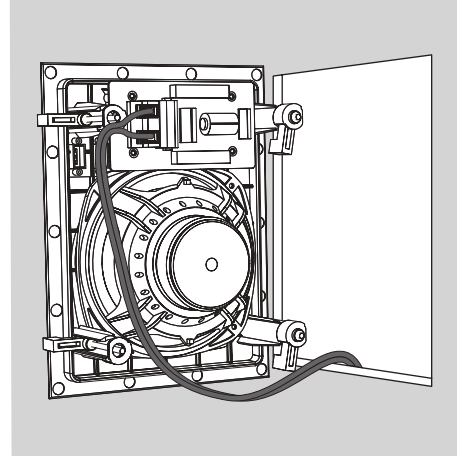

Speaker Clamps in Ready-to-Mount Position

5. Make sure all four speaker clamps are in their "ready-to-mount" position.

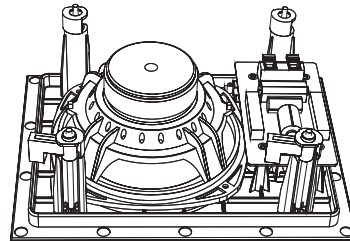

Speaker Clamps in Ready-to-Mount Position

6. Insert the speaker straight into the mounting opening. Tighten the speaker clamp screws on the front of the speaker baffle. The speaker clamps will automatically rotate into position and begin clamping the speaker.
- When you notice resistance on the screws the speaker has been clamped successfully.

IMPORTANT: Always use low-torque settings. NEVER over-tighten the clamp screws

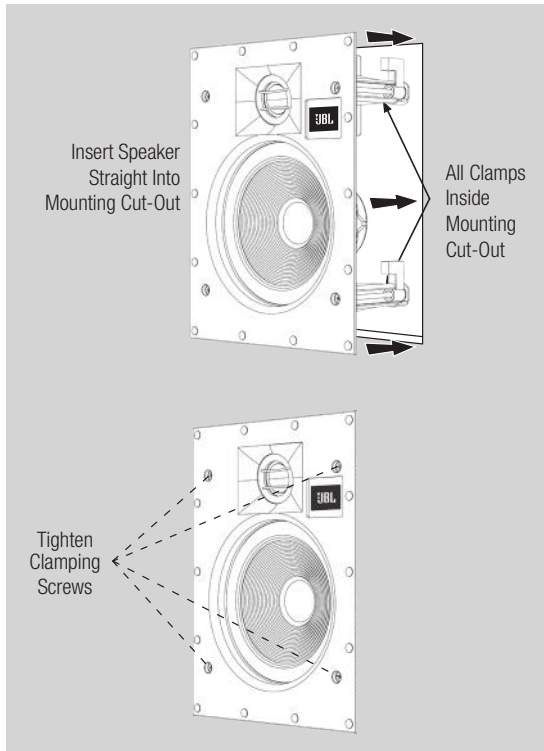

7. Attach the supplied grille. Powerful magnets in the speaker frame will securely hold the grille in place.

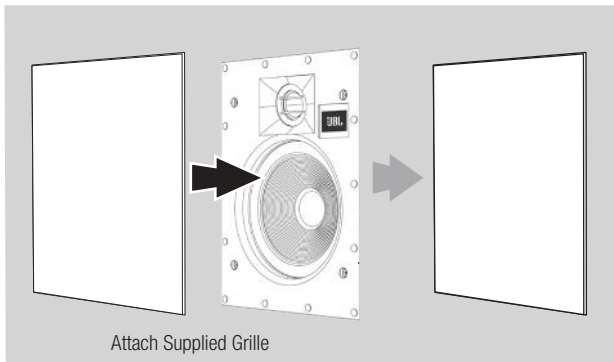

Painting the Grille

JBL architectural loudspeaker grilles can be painted to match any décor. If you wish to change the grille's color, its satin finish will function as a primer coat. For the best results follow this procedure:

1. Gently remove the scrim cloth from the back side of the grille before painting.
2. Use a high-quality spray paint and apply a thin coat of color. Ensure that the grille perforations remain free of paint. Filling them with paint will diminish the speaker's sound quality. If any perforations are plugged, use compressed air to blow the paint out of the perforations.

Note: If you find any grille perforations that are plugged with paint after the paint has dried, carefully use a straight pin or sewing needle to remove the paint.

3. We have included replacement scrim cloths. After the paint has dried, apply a light coat of spray adhesive to the inside of the perforated grille and attach a new scrim cloth. **IMPORTANT:** Never spray adhesive on the cloth.

ADJUSTMENTS

ADJUSTABLE ANGLE TWEETER

The JBL Studio 2 in-wall speaker models allow you to adjust the angle of the tweeter. To change the angle, press on the tweeter's outer ring as shown in the illustration below. Be careful not to touch the tweeter diaphragm or suspension.

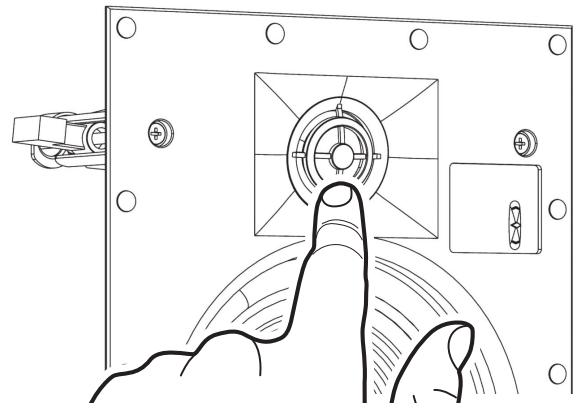

HIGH-FREQUENCY LEVEL CONTROL

The High-Frequency Level control lets you fine-tune the speaker's high frequency output to compensate for various acoustical environments. The control has three settings:

+: **Increases high-frequency output.** Set the switch to this position if the room has many features that absorb high-frequency sound energy, such as thick carpeting, drapes and fabric-covered furniture.

0: **Normal high-frequency output.** Set the switch to this position for most installations.

-: **Decreases high-frequency output.** Set the switch to this position if the room has many features that reflect high-frequency sound energy, such as large uncovered windows, bare tile floors and large expanses of bare walls, or if the speakers are used without grilles.

EXCESSIVE OUTPUT LEVELS

Your JBL loudspeakers feature custom-designed transducers and high-quality network components featuring high-order filters with steep cutoffs that reduce the potential of damage to individual speaker drivers and help the loudspeakers maintain their performance even under extreme operating conditions. However, all loudspeakers have limits when it comes to continuous playback. To extend these limits, avoid playback at volume levels that result in distorted or strained sound.

OBTAINING SERVICE

To obtain service, contact an authorized JBL dealer. Refer to *Limited Warranty*, below for more information.

DIMENSIONS

	Mounting Opening Dimensions	Mounting Depth	Overall Dimensions (w/grille)
STUDIO 2 6IW	(H x W): 9-13/16" x 7-9/32" (249mm x 185mm)	3-19/32" (91mm)	(H x W): 10-7/8" x 8-11/32" (276mm x 212mm)
STUDIO 2 8IW	(H x W): 11-15/16" x 8-15/16" (303mm x 227mm)	3-13/16" (97mm)	(H x W): 13" x 10" (330mm x 254mm)
STUDIO 2 55IW	(H x W): 14-1/8" x 6-13/32" (359mm x 163mm)	3.0" (76mm)	(H x W): 15-1/8" x 7-13/32" (384mm x 188mm)

Dimensions are subject to change without notice.

For complete performance specifications, please go to the JBL Web site: www.jbl.com.

LIMITED WARRANTY

In the USA, this product is covered by a limited 5-year warranty. Other countries may have different product warranty periods, which are governed by local regulations. For more information about product warranty please visit www.jbl.com or contact your dealer.