

Osmium

OSMB800/2-S

Design Highlights

- In built swivel bracket
- Titanium coloured shelf highlights create floating effect
- Toughened coloured glass tested to British and European standards
- Cable management
- Furniture glides to protect flooring
- Ideal as both a corner unit or flat to wall
- EAN: 5030752014647



Small but mighty, the Osmium TV Stand features a swivel bracket and excellent cable management. The floating shelf design and furniture glides ensure this versatile TV stand looks perfect either as a corner unit or flat to the wall.



Black

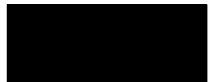

www.alphasondesigns.com



CSEurope@Dorel.com



01942 524100



Dorel Home Furnishings Europe Ltd, 244 Swan Lane, Hindley Green, Wigan, UK, WN2 4EY

alphason

Osmium

OSMB800/2-S

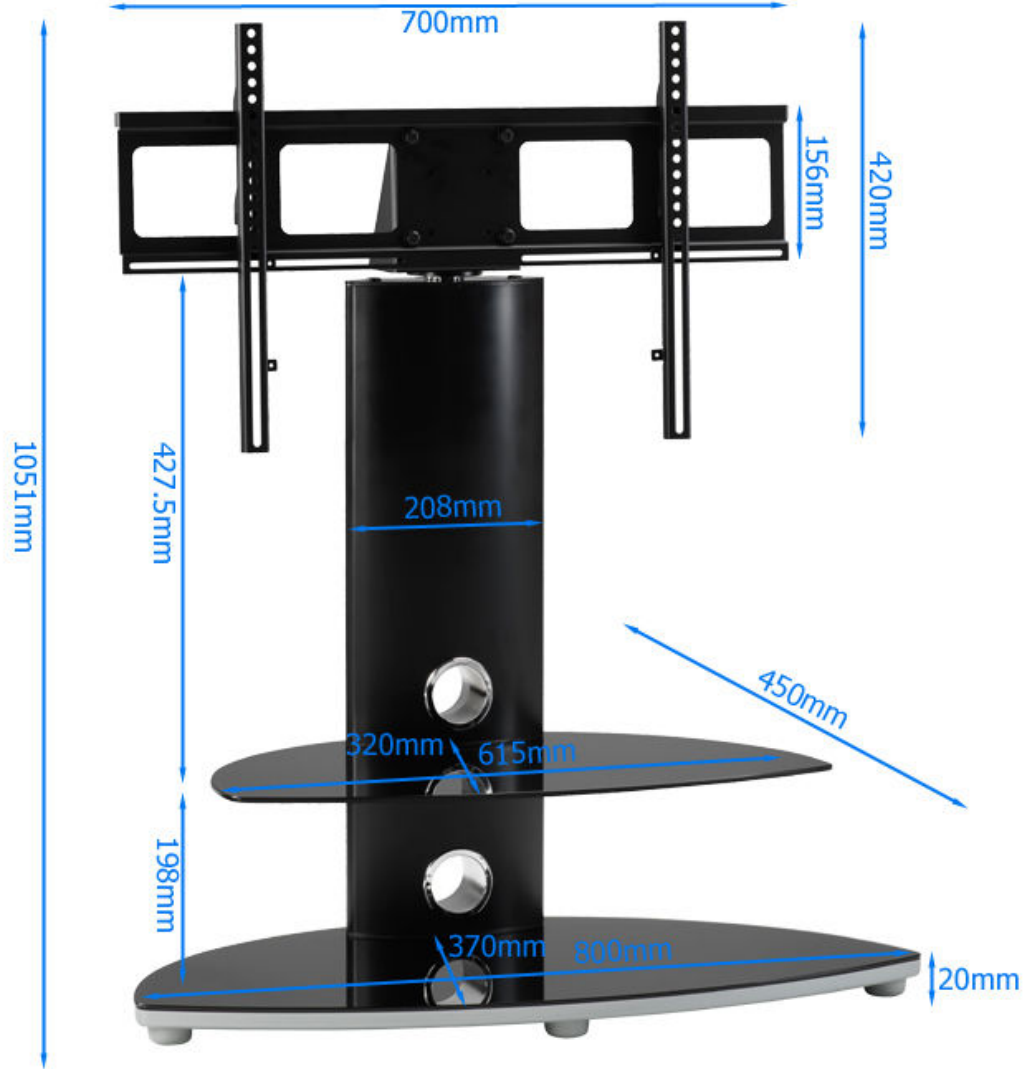

SPECIFYING

Max screen size (mm)	36"
Maximum load (kg)	40
Shelf load weights (kg)	Top: 15 Bot.: 30
Safety glass thickness (mm)	Top: 6 Bot: 5
Product Weight (kg)	14.5
Dims: H 1051 x W 800 x D 450 (mm)	

PACKAGING

Number of Boxes	1
Width (mm)	920
Height (mm)	150
Depth (mm)	520
Weight (kg)	17