

The JVC logo is displayed in a bold, red, sans-serif font in the top left corner of the advertisement.

**D-ILA Projectors**

DLA-NZ900, DLA-NZ800, DLA-NZ700, DLA-NZ500

The background of the advertisement features two JVC D-ILA projectors. The projector on the left is shown in a close-up, highlighting its lens and the side grille. The projector on the right is shown from a wider angle, showing its front grille and lens. Both projectors are dark in color, likely black or dark grey, and are set against a light, neutral background. The lighting is soft, creating a professional and high-quality aesthetic.

**D-ILA**

**The ART of PROJECTION**  
A True Cinematic Experience

*For more information on the new D-ILA projectors, scan or click  
on the QR code to access the Official Website*



# D-ILA The ART of PROJECTION



## 8K Home Theater Projectors

**8K**  
e-shift X



D-ILA home theater projectors in remarkable 8K resolution were made possible with over a quarter century of JVC engineering and technology. Discover the art of projection.



DLA-NZ900

**D-ILA** *BLU Escent Laser* **HDR** **HDR10+** **PURECOLOR HD**

100mm HQ Lens

Native contrast 150,000:1, Peak brightness: 3,300 lumens



DLA-NZ800

**D-ILA** *BLU Escent Laser* **HDR** **HDR10+** **PURECOLOR HD**

Native contrast 100,000:1, Peak brightness: 2,700 lumens

# VISION A True Cinematic Experience

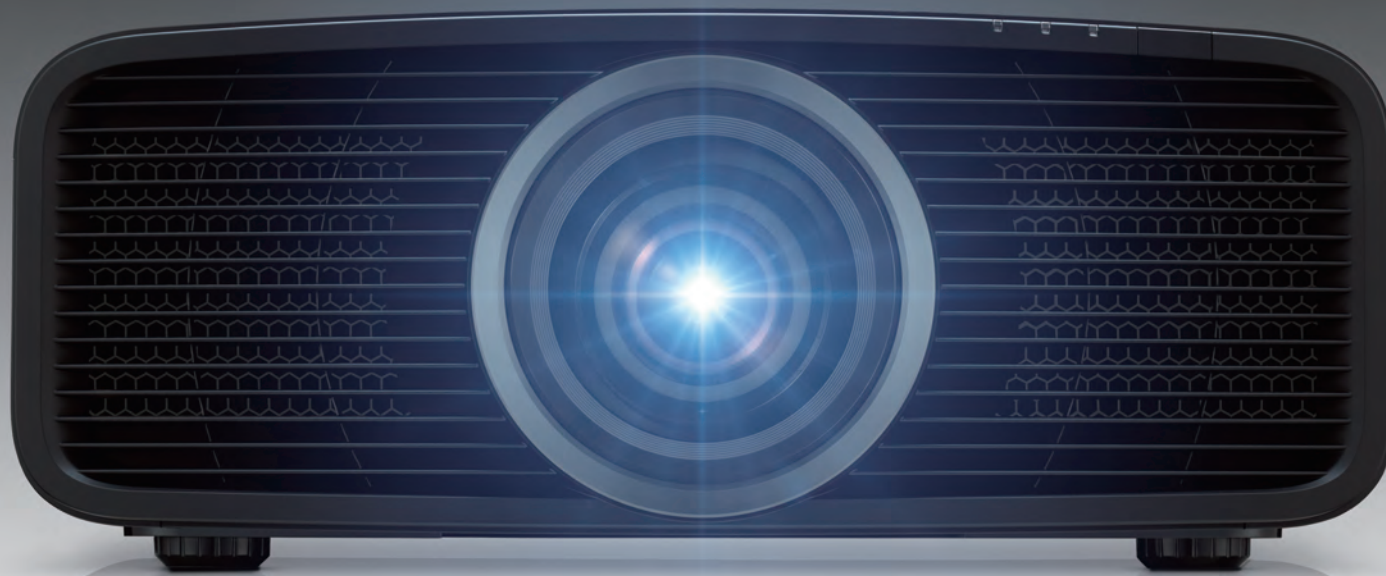

## Native 4K Home Theater Projectors

**4K**

All new native 4K resolution models featuring the world's smallest body\* satisfy a wider group of users with solid quality. Encounter a true cinematic experience.

\*As of September 2024 for projectors featuring native 4K panel.



DLA-NZ700

**D-ILA** *BLU Escent Laser* **HDR** **HDR10+**

 Native contrast 80,000:1, Peak brightness: 2,300 lumens



DLA-NZ500

**D-ILA** *BLU Escent Laser* **HDR** **HDR10+**

 Native contrast 40,000:1, Peak brightness: 2,000 lumens

# Exceptional Contrast, High Brightness, and Superior Resolution JVC Delivers Visual Excellence and Total Immersion

# 8K

8,192 x 4,320 pixels

## Exceptional Contrast

### Third-generation, Native 4K D-ILA Device

D-ILA device is the heart of projectors that plays an important role in projecting beautiful images. Device perfection continues to date – the third generation (Gen3) 0.69-inch native 4K D-ILA device has improved its alignment control of liquid crystals and enhanced the flatness of image pixels to offer 1.5-times\* the native contrast ratio on the DLA-NZ900 compared to the Gen2 device.

\*1.25-times on the DLA-NZ800

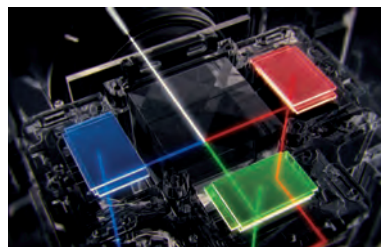

**4K D-ILA**

### Unparalleled Black Level and High Luminance

The DLA-NZ900 boasts the industry's highest native contrast of 150,000:1\* with the Gen3 0.69-inch 4K D-ILA device and wire-grid optical engine, however in combination with the dynamic laser light control, which analyzes the incoming video signal to automatically control the amount of outgoing laser light, a dynamic contrast level of  $\infty$ :1 (infinity to 1) can be achieved in scenes with pitch blackness by completely shutting off the light source.

\*100,000:1 on the DLA-NZ800



Starry sky with a sense of contrast

# High Brightness

## Light Source for Exceptional Brightness

Another essential aspect of projectors lies in their light source. JVC's D-ILA projectors feature "BLU-Escent Laser" light source to achieve exceptional peak brightness of 3,300 lumens on the DLA-NZ900 and 2,700 lumens on the DLA-NZ800, both with longevity of 20,000 hours. Power efficiency improvements made on the BLU-Escent Laser also contributes to saving power.

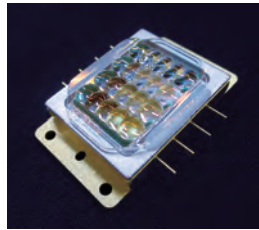

**BLU-Escent Laser**

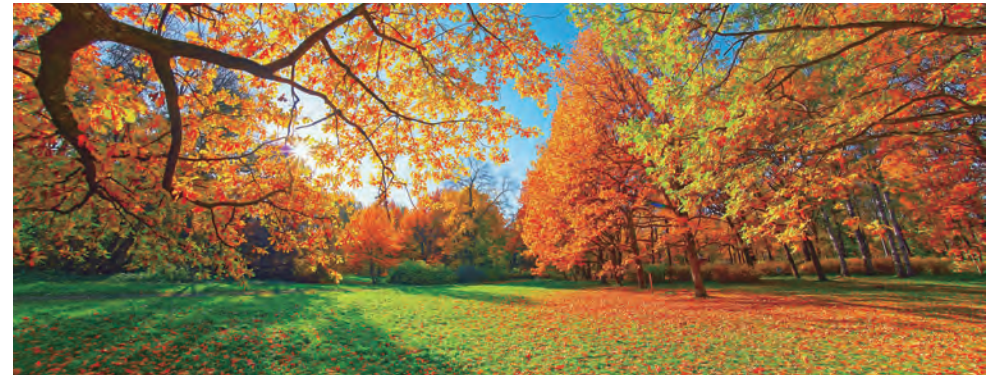

# Superior Resolution

## 8K Resolution Display with Gen2 8K/e-shiftX

Combining "e-shift technology" – a high-resolution display technology that doubles the resolution by shifting a pixel by 0.5 pixels in four directions up, down, left, and right – and "native 4K D-ILA devices", the second generation 8K/e-shiftX has made significant progress. Featuring the latest scaling engine, the Gen2 8K/e-shiftX drastically improves the projector's sharpness and detail across a wide range of content.



See how the native 4K image becomes sharper as if it is alive with the newest 8K/e-shiftX processing.

## 8K60p Input for 8K Content, 4K120p Input for Games and More

The 8K projectors support a variety of inputs including full 48Gbps 8K60p. By adopting LSIs developed with the latest technology, it is now possible to process four times the amount of information from input to D-ILA device instantly and correctly display 8K signals. As a result, users can enjoy stable high-quality 8K images at all times. Also, using 4K120p input with the Low Latency Mode further improves response to the player's rapid operations for displaying high frame-rate gaming content on large screens.



## All-glass Lens System Designed for the 8K Projectors

The DLA-NZ900 is equipped with an 18-element, 16-group 100-mm all-glass lens\* featuring a full aluminum lens barrel. To project high-resolution 8K images to every corner of the screen, the projector incorporates five ED lenses calibrated for differences in the R/G/B refractive index to reduce chromatic aberration and color fringing when lens shift kicks in to deliver precise reproduction of 4K- or 8K-resolution projection.



\*The DLA-NZ800 features 17-element, 15-group 65-mm all-glass lens without ED lenses.

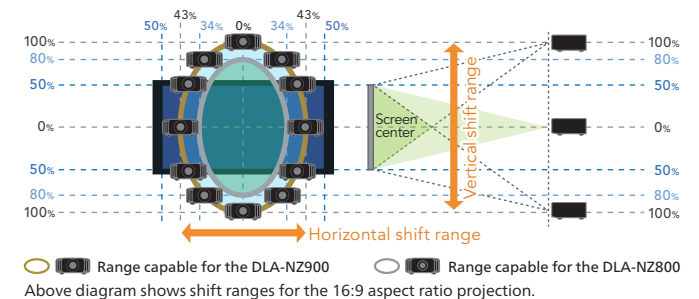

Refined Sleek Design, Native 4K, BLU-Escent Laser  
Discover Your Next Cinematic Journey

Native **4K**  
4,096 x 2,160 pixels

## Compact Design

### World's Smallest\* Native 4K Projectors

Completely redesigned with a new chassis, optical units, lens system, and circuit boards, the DLA-NZ700 and NZ500 are the world's smallest native 4K projectors\*. While maintaining a small footprint, these models incorporate JVC's proprietary BLU-Escent laser light source and native 4K devices found on the DLA-NZ900 and NZ800. The horizontal grille on the front panel expresses the center lens in a symbolic manner, while the rounded corners of the body emphasize user-friendliness. What's more, the DLA-NZ500 comes available in two colors of black and white to match any interior settings.

\*As of September 2024 for projectors featuring native 4K panel.



### Superb Intake/Exhaust Layout

A straight cooling system that draws air in from the front and exhausts it out the back has been applied on the DLA-NZ700/NZ500 to emphasize compactness of the body, reduce the impact from heat on the projection screen and enable greater flexibility in installation.

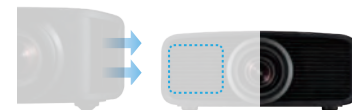

On the DLA-NZ900 and NZ800, exhaust releases air from the front towards the sides, whereas the newly designed straight cooling system draws air in from the front.

# Native 4K Projection

## Pixel Perfect Resolution with Native 4K Input and 4K D-ILA Device

Signals input via the 32Gbps 4K/60p HDMI terminal go through the third generation (Gen3)\* 0.69-inch native 4K D-ILA devices to project full native 4K (4,096 x 2,160 pixels) resolution images on the screen with uniform brightness and more subtle blacks. With the combination of native 4K input and device, improved overall image quality can be achieved.

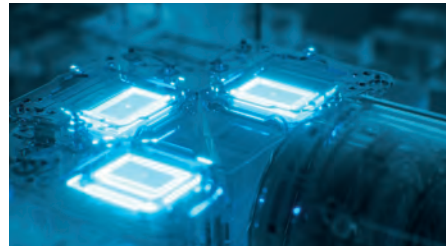

**4K D-ILA**

\*Only on the DLA-NZ700

## Unbeatable Black Level and High Luminance

Native contrast of 80,000:1\* with dynamic contrast of  $\infty$ :1 (infinity to 1) on the DLA-NZ700 is realized with the combination of the latest 0.69-inch native 4K D-ILA device with wire-grid optical engine and the BLU-Escent laser light source with dynamic laser light control. As a result, images brimming with reality can be achieved.



\*DLA-NZ500 offers native contrast of 40,000:1.

# New BLU-Escent Laser and 4K Lens System

## BLU-Escent Laser for Remarkably Bright Images

JVC's proprietary "BLU-Escent Laser" light source designed exclusively for the new models is featured to achieve exceptional peak brightness of 2,300 lumens on the DLA-NZ700 and 2,000 lumens on the DLA-NZ500, both with longevity of 20,000 hours.

**BLU-Escent Laser**

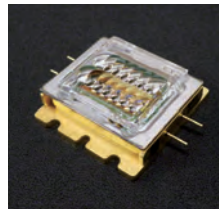

## Controlling the Luminance on BLU-Escent Laser

Luminance of projectors equipped with BLU-Escent Laser can be finely adjusted according to the environment and preference using the Light Source Control with a total of 101 (0 - 100) luminance control steps.

101 luminance control steps (0 - 100 steps)

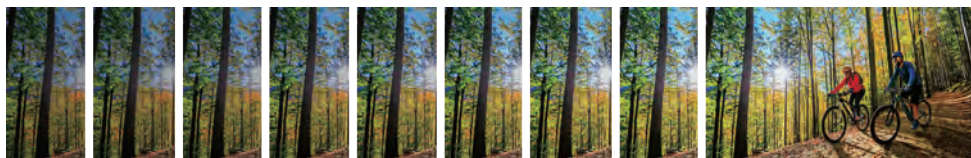

0 ← → 100

## New Fully Motorized 4K Lens

The newly introduced compact projectors feature native 4K lens with a 15-element, 11-group, 80-mm lens with motorized focus, zoom, and shift for faithful reproduction of distortion-free, high-resolution native 4K images. In addition to a wide lens shift range of 70% vertical and 28% horizontal, these projectors are equipped with a 1.6x zoom that enables a projection distance of 3 meters at 100 inches, making these flexible for a variety of installation environments without sacrificing image quality. Its Lens Memory function comes in handy when switching between conventional 16:9- and cinemascope-sized screens.



15-element, 11-group  
80-mm lens

80mm



Lens shift function:  
70 % vertical, 28 % horizontal

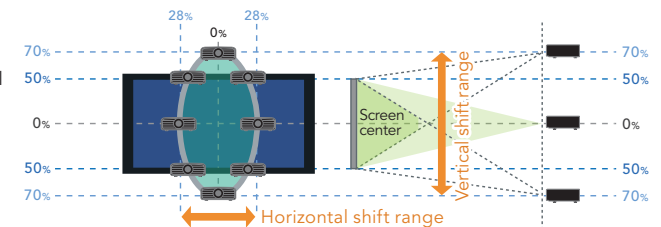

Above diagram shows shift ranges for the 16:9 aspect ratio projection.

# Enjoy HDR Content to Its Fullest



## HDR Drastically Improves Expressive Power of Images

When it comes to reproducing the rich video information of HDR content, rely on the new D-ILA projectors as these models support all HDR formats including HDR10 for Blu-ray and streaming, HLG for broadcasting, and the HDR10+ with dynamic metadata compatibility. The projectors' improvements for higher brightness and contrast have helped to achieve a wider dynamic range, allowing users to enjoy an immersive experience with HDR images full of reality.



Original Image



Frame Adapt HDR (Conventional)



Frame Adapt HDR Generation 2

MOVIE A



## Gen2 Frame Adapt HDR Function

The Gen2 Frame Adapt HDR function's latest proprietary algorithm instantaneously analyzes the maximum brightness of an HDR10 content per scene or frame and performs real-time tone mapping to optimal dynamic range for high-definition video projection. The proprietary algorithm's improved tone curve selection also reproduces HDR images with a wider dynamic range that are brighter and more colorful.

## DML (Display Mastering Luminance) for Better HDR Experience

DML (Max Display Mastering Luminance) metadata, which represents the nit level of the professional monitor used to grade the movie to the director's standards, is used to set the dynamic range of the title for improved HDR tone mapping. Both DML and MaxCLL values are used for the HDR levels.

## Vivid Reproduction of HDR Sources Containing Wide Color Gamut

Even when HDR content using a wide color gamut equivalent to BT.709 and DCI-P3\* is projected on these projectors, the original cinema filter combined with the BLU-Escent Laser work together to reproduce rich colors, such as the gradations of the sky and ocean, the contrast of red roses, or a row of fresh green trees.

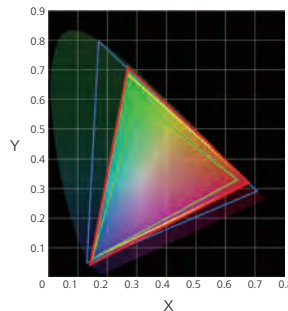

— DLA-NZ900/NZ800/NZ700 — BT.709 (sRGB) — DCI — BT.2020

## Deeper Blacks for Richer Gradation

The new Deep Black Tone Control on the Gen2 Frame Adapt HDR with a new algorithm further subdues tones in dark areas to achieve more realistic darkness. This function maximizes the dynamic range of the new-generation 4K D-ILA devices and delivers images with more contrast than ever before. Scenes with light and dark shades such as nightscapes can be projected with greater realism.

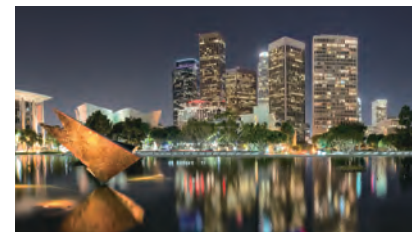

Conventional



New Deep Black Tone Control

\* The DLA-NZ500 supports 100% sRGB.



# Projecting the Content More Beautifully and Faithfully

## Picture Mode “Vivid”

To reproduce content with a narrow dynamic range in more saturated colors, conventional Natural mode has been improved to the new “Vivid” mode. This mode is excellent for projecting classic SDR works with greater vividness that are yet popular in streaming content and gaming CGs.



Conventional Natural mode



New “Vivid” mode



FILMMAKER MODE™

## Recreating the Creator’s Original Intentions

FILMMAKER MODE™ was developed by the UHD Alliance with the aim of faithfully reproducing the filmmakers’ intentions in the home. When using the mode, picture quality adjustments such as frame interpolation and noise reduction are turned off, and the color temperature is set to D65 (6500K), allowing users to enjoy movies and documentaries with picture quality that is faithful to the original master.

## Clear Motion Drive

Clear Motion Drive allows viewers to enjoy smoother and clearer images. With the DLA-NZ900/NZ800 when inputting signals at 24/25/30/50/60Hz, compensation accuracy has been improved in the periphery of intersecting objects.



Clear Motion Drive: Off



Clear Motion Drive: On

## Adjustments and Installation

- Ultra-high Contrast Optics not only contributes to achieving high optical brightness, but also suppresses the return of unnecessary light to the projection screen for clear and colorful images.
- Auto Calibration function that uses an optical sensor with proprietary software\* optimizing all essential elements found in the image, including color balance, gamma characteristics, etc. that change according to installation and usage conditions.

\*Optional optical sensor and proprietary software, PC, and LAN cable are required to perform auto calibration function.

- Installation Mode: The DLA-NZ900 and NZ800 models allow user to centrally manage 8 settings such as Lens Control, and Pixel Adjustment. A total of 10 different mode settings can be named, stored and called up. On the DLA-NZ700 and NZ500 models, up to 5 settings including Lens Memory, Pixel Adjustment, and Screen Mask can be stored and called up.

- More than 200 Screen Adjustment modes can be used to correct imbalances caused by screen characteristics.



Scan or click on the QR code to access the Screen Adjustment Mode Table



## ● Specifications

GENERAL		DLA-NZ900	DLA-NZ800	DLA-NZ700	DLA-NZ500
Device		0.69-inch Native 4K D-ILA Device (4,096 x 2,160) x3			
Display Resolution		8,192 x 4,320 (Gen2 8K/e-shiftX)		4,096 x 2,160 (Native)	
Lens	Type	x2 motorized zoom & focus, all-glass lens		x1.6 motorized zoom & focus, native 4K lens	
	Diameter	100 mm	65 mm	80 mm	
Lens Shift (motorized in 16:9 aspect ratio)	Vertical	±100%	±80%	±70%	
	Horizontal	±43%	±34%	±28%	
Projection Display Size (diagonal)		60 inch – 300 inch		60 inch – 200 inch	
Light Source		BLU-Escent Laser diode			
Brightness		3,300 lm	2,700 lm	2,300 lm	2,000 lm
Contrast Ratio	Dynamic	∞:1			
	Native	150,000:1	100,000:1	80,000:1	40,000:1
Cinema Filter (Color Gamut)		DCI 98%/BT.2020 73%			sRGB 100%
Input Terminal	HDMI	2 (48 Gbps/HDCP 2.3, no CEC support)		2 (32 Gbps/HDCP 2.3, no CEC support)	
Output Terminal	TRIGGER	1 (Mini Jack, DC 12 V/100 mA)		—	
	3D SYNCHRO	1 (Mini Din 3-pin)		—	
Control Terminal	RS 232C	1 (D-sub 9pin)		—	
	LAN	1 (RJ45)			
Service Terminal	SERVICE	1 (USB Type A) for firmware update and backing up settings			
Power Consumption	Projector in Use	440 W		280W	
	Eco-mode Standby			0.3 W	
	Standby			1.5 W	
Fan Noise		24 dB (LD power at minimum)		23 dB (LD power at minimum)	
Power Requirement		AC 100-240V, 50/60Hz			
Dimensions (W x H x D, including feet)		500 mm x 234 mm x 528 mm	500 mm x 234 mm x 505 mm	450 mm x 181 mm x 479 mm	
Weight (net)		55.7 lb. / 25.3 kg	50.9 lb. / 23.1 kg	32.6 lb. / 14.8 kg	32.2 lb. / 14.6 kg

FEATURES		DLA-NZ900	DLA-NZ800	DLA-NZ700	DLA-NZ500
Max Input		80K60p and 4K120p		4K60p	
Light Source Control by Slider Adjustment		101 steps			
Ultra-High Contrast Optics		•			
HDR	HDR10+	•			
	HLG	•			
	Mastering Info Display	• (Max CLL/Max FALL/DML)			
	Frame Adapt HDR Gen2	•			
	Deep Black Tone Control	•			
Theater Optimizer		•		—	—
"Vivid" Mode for SDR		•			
FILMMAKER MODE™		•			
3D Support		•			
Clear Motion Drive		•			
Motion Enhance		• (black frame insertion at 60Hz input only)			
Low Latency Mode		•			
Auto Calibration		•			
Installation Mode		• (max. 10 memories)		• (max. 5 memories)	
ISFccc Certification		•			
Screen Adjustment Mode		•			
USB Back-up		•			

Note: Values are typical. Depends on the projector setting conditions and usage environment.

## ● External Dimensions

Unit: (mm)

### DLA-NZ900

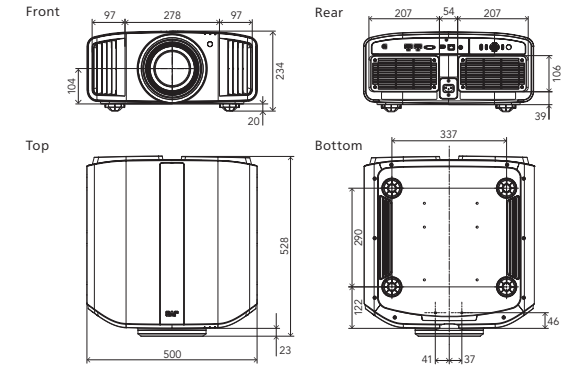

### DLA-NZ800

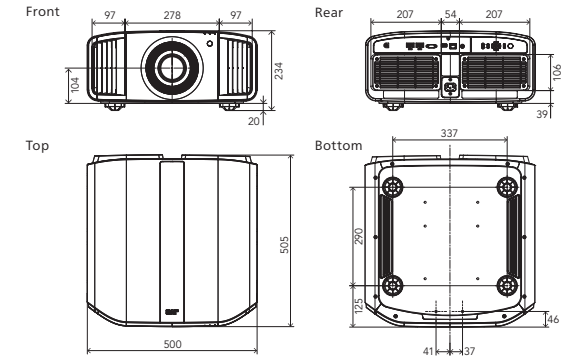

### DLA-NZ700/NZ500

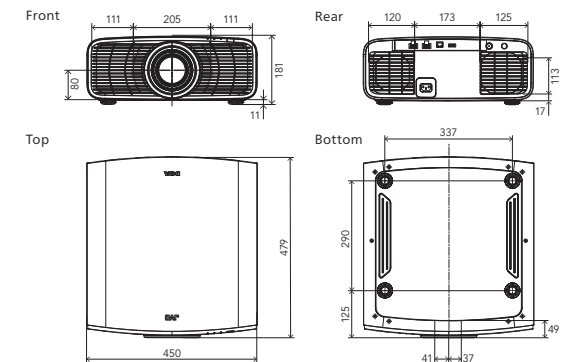

## ● Projection Distance Chart

### DLA-NZ900

Screen diagonal (inch)	Screen size aspect ratio: 16:9				Screen size aspect ratio: 2.4:1 (Cinematic)			
	Screen size		Projection distance		Screen size		Projection distance	
	Width (mm)	Height (mm)	Wide (m)	Tele (m)	Width (mm)	Height (mm)	Wide (m)	Tele (m)
60	1,328	747	1.75	3.61	1,402	586	1.86	3.83
90	1,992	1,121	2.67	5.46	2,103	879	2.83	5.78
100	2,214	1,245	2.98	6.07	2,337	977	3.16	6.43
110	2,435	1,370	3.28	6.69	2,571	1,075	3.48	7.09
120	2,657	1,494	3.59	7.30	2,805	1,172	3.81	7.74
150	3,321	1,868	4.51	9.15	3,506	1,465	4.78	9.69
200	4,428	2,491	6.04	12.22	4,674	1,954	6.40	12.95
250	5,535	3,113	7.57	15.30	5,843	2,442	8.02	16.20
280	6,199	3,487	8.48	17.14	—	—	—	—

Note: Projection distances are design specifications, so there is ±5% variation.

### DLA-NZ800

Screen diagonal (inch)	Screen size aspect ratio: 16:9				Screen size aspect ratio: 2.4:1 (Cinematic)			
	Screen size		Projection distance		Screen size		Projection distance	
	Width (mm)	Height (mm)	Wide (m)	Tele (m)	Width (mm)	Height (mm)	Wide (m)	Tele (m)
60	1,328	747	1.88	3.85	1,402	586	1.99	4.08
90	1,992	1,121	2.84	5.80	2,103	879	3.01	6.15
100	2,214	1,245	3.16	6.45	2,337	977	3.35	6.83
110	2,435	1,370	3.49	7.10	2,571	1,075	3.69	7.52
120	2,657	1,494	3.81	7.75	2,805	1,172	4.03	8.21
150	3,321	1,868	4.77	9.70	3,506	1,465	5.05	10.27
200	4,428	2,491	6.38	12.95	—	—	—	—

Note: Projection distances are design specifications, so there is ±5% variation.

### DLA-NZ700/NZ500

Screen diagonal (inch)	Screen size aspect ratio: 16:9				Screen size aspect ratio: 2.4:1 (Cinematic)			
	Screen size		Projection distance		Screen size		Projection distance	
	Width (mm)	Height (mm)	Wide (m)	Tele (m)	Width (mm)	Height (mm)	Wide (m)	Tele (m)
60	1,328	747	1.77	2.85	1,407	586	1.87	3.03
90	1,992	1,121	2.68	4.31	2,110	879	2.84	4.56
100	2,214	1,245	2.98	4.79	2,345	977	3.16	5.08
110	2,435	1,370	3.28	5.28	2,579	1,075	3.48	5.59
120	2,657	1,494	3.58	5.76	2,814	1,172	3.80	6.10
150	3,321	1,868	4.49	7.21	3,517	1,465	4.76	7.64
200	4,428	2,491	6.01	9.63	4,689	1,954	6.37	10.21

Note: Projection distances are design specifications, so there is ±5% variation.

## ● Optional Accessories

### VX-UH1150LC HDMI Cable

15 m long, 48Gbps HDMI cable that supports 8K60p/4K120p transmission. A fully-certified Ultra High Speed HDMI™ Cable.



### PK-AG3 RF 3D Glasses

Full recharge takes 2.5 hours and works for 100 hours. Includes USB-Mini USB cable.



### PK-EM2 RF 3D Emitter

Signal reaches to 10 meters. No IR signal interruption with other equipment. No limitation to the number of the glasses.



## ● Connectors

### DLA-NZ900/NZ800

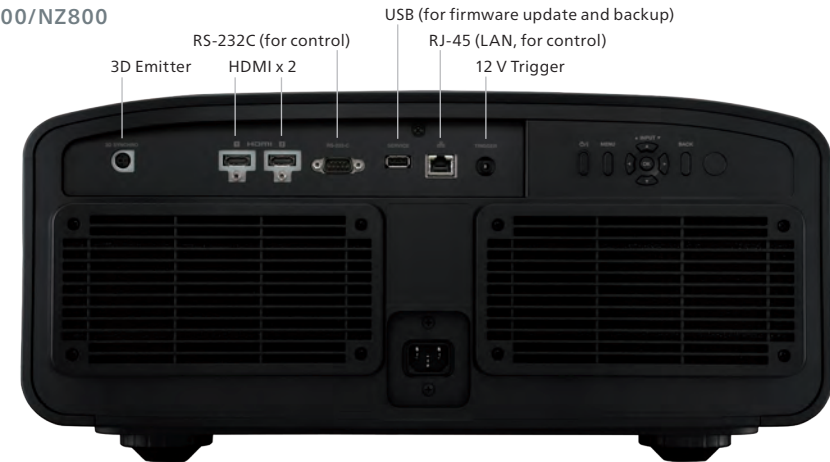

### DLA-NZ700/NZ500

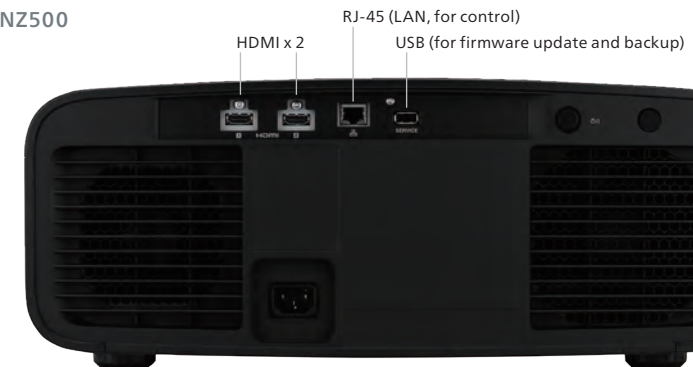

# D-ILA The ART of PROJECTION A True Cinematic Experience



• D-ILA and e-shift are registered trademarks of JVCKENWOOD Corporation. • BLU-Escent Laser is a trademark of JVCKENWOOD Corporation. • FILMMAKER MODE™ logo and its trade name are registered trademarks of UHD Alliance, Inc. in the US and other countries. • HDR10+™ logo is a trademark of HDR10+ Technologies, LLC. • YouTube™ is a trademark or registered trademark of Google LLC. • ISF is a registered trademark of Imaging Science Foundation, Inc. • The terms HDMI, HDMI High-Definition Multimedia Interface, HDMI trade dress and the HDMI Logos are trademarks or registered trademarks of HDMI Licensing Administrator, Inc. • All other brand or product names may be trademarks and/or registered trademarks of their respective owners. • All pictures in this brochure are simulated. • Design and specifications are subject to change without notice. • Any rights not expressly granted herein are reserved.

Copyright © 2024, JVCKENWOOD Corporation. All Rights Reserved.

# JVC

DISTRIBUTED BY

<https://eu.jvc.com/>  
<http://www.jvc.net/>