

THE MH SERIES

MH2 is the third desk in Soundcraft's MH Series - consoles that deliver consistently high levels of performance and dependability in all applications, large and small.



MH4



MH3



MH2



Soundcraft Registered Community Trade Mark/RTM No. 000557827

SOUNDCRAFT

HARMAN INTERNATIONAL INDUSTRIES LTD.,
CRANBORNE HOUSE, CRANBORNE ROAD
POTTERS BAR, HERTS, EN6 3JN, UK
T: +44 (0)1707 665000
F: +44 (0)1707 660742
E: info@soundcraft.com

SOUNDCRAFT USA

8500 BALBOA BLVD.,
NORTHRIDGE, CA 91329, USA
T: +1-818-920-3212
F: +1-818-920-3208
E: soundcraft-usa@harman.com

www.soundcraft.com

Soundcraft reserves the right to improve or otherwise alter any information supplied in this document or any other documentation supplied hereafter. E&OE 07/05
This equipment complies with the EMC Directive 89/336/EEC

Part No: ZL0633



A Harman International Company

TYPICAL SPECIFICATIONS

Frequency Response	XLR Input to any Output..... +0/-1dB, 20Hz - 20kHz
T.H.D. and Noise (All measurements at 0dBu)	XLR In to Mix Out <0.03% @ 1kHz <0.03% @ 10kHz
Mic Input E.I.N.	22Hz-22kHz bandwidth, unweighted..... <-128dBu (150Ω source)
Residual Noise	Mix Output; no inputs routed, Mix fader @ 0dB -90dBu
Bus Noise	Mix Output; 48 channels routed, input faders @ -∞, Mix fader 0dB..... <-83dBu Grp Output; 48 channels routed, input faders @ -∞, Grp fader 0dB <-82dBu Aux Output; 48 channels routed, input sends @ -∞, Aux fader 0dB <-84dBu
Crosstalk	1kHz, +20dBu input signals Input Channel muting..... >95dB Input fader cutoff >90dB Input pan pot isolation..... >75dB Mix routing isolation >90dB Group routing isolation..... >90dB Aux send off..... >80dB
CMRR	Mono input..... >84dB @ 1kHz
Input & Output Levels	Mic Input..... +26dBu max. Balanced Inputs +21dBu max. Balanced Outputs..... +21dBu max. Nominal Operating Level..... 0dBu
Input & Output Impedances	Mic Input..... >2kΩ All other Inputs..... >10kΩ Headphone Output..... 25Ω Recommended Headphone Impedance 50-600Ω All other Outputs..... <75Ω
Oscillator	63Hz to 10kHz, variable level
HP Filter (Mono Input)	30-400Hz, 12dB/octave
EQ (Mono Input)	HF..... 1.2kHz - 20kHz, ±15dB, shelving Hi-Mid 750Hz - 13kHz, ±15dB, Q=1.5 Lo-Mid..... 75Hz - 1.3kHz, ±15dB, Q=1.5 LF..... 30Hz - 500Hz, ±15dB, shelving
Metering	12-segment LED bargraphs for all inputs. 12-segment LED bargraphs for 8 Fader-controlled Outputs, plus LR & C. Aux 9/10 metered via the LR meters.
Power Consumption	Mains Power: 48 Ch: 300W max
Operating conditions	Temperature Range -10°C to +30°C Relative Humidity 0% to 80%

Note: These figures are typical of performance in a normal electromagnetic environment. Performance may be degraded in severe conditions. All measurements refer to electronically balanced inputs and outputs with VCAs enabled. Input and output transformers may affect these specifications.

MH 2

LIVE PERFORMANCE CONSOLE



VCA power for the people

MH
2

Featuring the most sophisticated VCA grouping available at this price, the new MH2 from Soundcraft satisfies the demand for the critical features of a large, stadium-style mixing solution in a small-footprint, fixed frame format. And with the same flexible, dual-purpose FOH and Monitor mixing found on the MH4 and MH3, it achieves a performance / price ratio unheard of in any other console in its class.

Fader control of Group or Aux outputs is selected at the touch of a button for familiar and uncomplicated operation. Soundcraft's legendary sound quality is delivered via MH4/3 mic preamps, classic British EQ and meticulous circuit design. And with important new features including separate line inputs on every channel, the argument for mixing with MH2 is compelling.

Four frame sizes are available, all with an integrated switched mode PSU which can be removed for easy maintenance. Naturally, a rear-panel connector is provided to fit an external power supply for complete dual-redundancy assurance.



KEY FEATURES

- Frame sizes: 24+4, 32+4, 40+4 and 48+4
- Styling based closely on MH3/4, with a single-piece front panel and individual channel PCBs
- MH3/4 mic amp design with 50dB range plus -20dB pad and separate 1/4" Line input
- Swept high-pass filter and fully-swept 4-band EQ
- 10 Auxes, of which 2 can be switched to create 1 x stereo send
- Pre/post fader switching in pairs (except 5-8 as one block of 4)
- 8 full-time Group busses with paired routing
- LCR panning on inputs to mix
- 8 VCAs and 6 Mute Groups
- 4 Stereo Input channels with mic/line capability
- 4 Stereo line returns with 3-band fixed EQ, returns can route to output channels
- 11x4 Matrix built-in
- 10 x linear 60mm output faders, plus 8 rotary output faders with SWAP facility to allow linear faders to control either all 10 Auxes or 8 Grps and 2 Auxes
- Inserts on Groups and Mix outputs (Group insert moves between Grp & Aux)
- 12-segment Input and Output metering
- Central assignment of VCA Groups, with individual LED displays per channel

Mono Input Module



Gain

Adjusts the sensitivity of the electronically balanced XLR input, from +15dBu to +60dB.

+48V Phantom Power

Applies +48V phantom power to the input XLR.

-20dB Pad

Reduces the input sensitivity of the XLR by 20dB, to allow line level signals to be connected via the XLR.

Line Switch

Selects a separate high-impedance input via 1/4" jack on the rear panel. This signal replaces the XLR signal and is attenuated by 20dB.

Peak LED

Illuminates when the internal signal reaches 3dB below clipping level, monitored at two points, pre and post the EQ.

Phase

Reverses the phase of the selected input.

Hi-Pass Filter

The switchable 12dB/octave variable high-pass filter can be varied from 30-400Hz for effective removal of unwanted low frequency content.

EQ Section

The EQ section is four band, with shelving sweep high and low frequency sections, and swept high-mid and low-mid bands. The frequency ranges are 1.2kHz-20kHz (HF), 750Hz-13kHz (High Mid), 75Hz-1.3kHz (Low Mid) and 30Hz-500Hz (LF) with 15dB cut/boost available at any frequency. The Q is fixed on the two mid bands at 1.5.

Balanced Insert Point

Separate jacks provide a pre-EQ balanced send and return, at a nominal level of 0dBu.

Direct Output

A Direct Output on balanced 1/4" jack is source-selected by the DIR PST switch. The function of the switch when up and down can be selected by 2 internal PCB jumpers:

	DIR PST 'UP'	DIR PST 'DOWN'
Default	Non-muted pre-filter	Post-EQ
Alternative	Non-muted pre-fade	Post-fade

Aux Sends

There are 10 Aux sends, which can be used either as FX sends in FOH use, or monitor mixes for monitoring. Aux 9&10 can be switched to work as a stereo pair, with separate level and pan for use as an in-ear send, using the adjacent STE switch. Each send has a maximum gain of +6dB. The Auxes can be switched pre- or post-fader by the adjacent PRE switches, which are in pairs for Aux 1-4 and Aux 9,10 and as one group for Auxes 5-8. The pre-fade signal for all Auxes is normally post-EQ but can be switched to pre-EQ using the AUX PREQ switch (both feeds follow the channel mute).

Subgroup Routing

In addition to the 10 Aux sends, 8 busses are provided for audio subgrouping. Routing is via 4 paired buttons, with the channel pan pot controlling the signal split between odd and even groups.



Mix Bus Routing and Pan Controls

The signal is sent to the stereo mix bus and the mono (C) bus using the MIX and C switches.

The PAN control, which gives 3dB centre drop, operates on the STE bus and group bus signals. The C bus is always fed directly with the post-fader signal at unity gain, unless LCR panning is engaged.

LCR Panning

The LCR switch changes the mode of the Pan pot from normal left-right panning with a 3dB centre drop, to 3-way LCR panning, requiring both the mono bus and stereo mix bus to be routed, and the pan pot panning from left to mono, mono to right. When the pot is physically centred, there is no output to the left and right mix busses.

SOLO

The SOLO button provides a PFL feed to the engineer's headphones or monitors, or triggers a destructive solo in place, depending on the mode selection at the master section. The SOLO button can also be activated remotely from a VCA solo when assigned to a VCA group, giving stereo AFL.

Intercancel or additive soloing is possible, with or without input priority, and solos can be cleared with a single button press at the master section.

The SOLO button also features automatic momentary operation, by pressing and holding for more than 0.5 seconds.



MUTE

The MUTE switch mutes the signal to all busses, including pre-fade Aux sends. The mute can also be activated by the mute group system, an SIP mute signal or a VCA mute signal. It is also possible to activate the mute by sending a MIDI note message into the console's MIDI Input. The same MIDI messages are transmitted when the mute switch is manually pressed. A preview mode allows editing and checking of mute groups without disturbing the audio passing through the desk, and mutes can be set 'Safe'.

SAFE/PREV LED

The SAFE/PREV LED is used to indicate Mute Safe mode or Preview mode. The channel is toggled in or out of Safe mode using the MUTE switch, after first engaging EDIT SAFES mode on the master fader panel. Preview status is indicated by flashing illumination, upon entering Preview mode from the master module, if the Mute is present in the previewed mute group.

VCA Assignment

Each channel can be assigned to any combination of 8 VCA subgroups, using the SOLO button on each channel, in conjunction with the VCA master SOLO switches in VCA Assign mode.

Once assigned to a VCA group, the channel's fader level, mute and solo button come under the control of the VCA master controls, but can still be operated locally. Assignments are displayed on the 8 LEDs next to each channel fader.

LED Input Metering

Every channel is fitted with a 12-segment LED bargraph meter, positioned next to each fader for maximum visibility and giving immediate graphic indication of incoming signals at the output of the EQ.

Stereo Input Module



Gain

A stereo version of the mono input's high performance preamp offers the same gain range of +15dBu to +60dBu. A dual gang pot adjusts the sensitivity of left and right inputs together. Both inputs are available on XLRs and are electronically balanced.

+48V Phantom Power

Applies +48V phantom power to both left and right input XLRs.

-20dB Pad

Reduces the input sensitivity of both left and right XLR inputs by 20dB, to allow line level signals to be connected via the XLRs.

Line Switch

Selects a separate pair of high-impedance 1/4" balanced jack inputs on the rear panel, bypassing the XLR input and PAD. The signal is attenuated by 20dB.

Hi-Pass Filter

Switches in a 12dB per octave stereo high-pass filter at a fixed frequency of 80Hz.

Peak LED

Monitors the left and right signals post filter. The LED illuminates when the internal level of either left or right channels reaches 3dB below clipping.

Phase

Reverses the polarity of the left channel only, before the input stage.

Mono L & R Switches

Pressing either of these cuts the input signal to the other channel, and feeds the selected channel signal to both left and right channel paths. If both switches are pressed at the same time, a sum of left and right inputs is fed to both paths of the channel.

EQ Section

The EQ section is a stereo four band, with fixed frequencies on all bands. The frequencies are 12kHz (HF), 2.5kHz (High Mid), 450Hz (Low Mid) and 80Hz (LF), with 15dB cut/boost available at any frequency. The Q is fixed on both bands at 0.9.

Aux Sends

As on the mono input there are 10 sends, for FX or monitor use. Each send has a maximum gain of +6dB, and is fed from a mono sum of the left and right signals, except Auxes 9&10, which can be switched to form a stereo pair for an in-ear send, with separate level and balance, using the adjacent STE switch. The Auxes can be switched pre- or post-fader by the adjacent PRE switches, which are in pairs for Aux 1-4 and Aux 9,10 and as one group for Auxes 5-8. When switched to pre-fade, all Auxes are sourced from post-EQ.

Subgroup Routing

Signal is sent to the Group busses 1-8 via the 4 paired routing buttons 1-2, 3-4, 5-6, and 7-8. The signal to each odd-even pair of group busses is controlled by the channel balance control.

Mix Bus Routing and Balance Controls

The signal is sent to the stereo mix bus and the mono bus using the MIX and C switches.

The BAL control allows the left signal to be faded down to zero level when turned fully clockwise, and vice-versa for the right signal. In the centre position, both channels are fed at unity gain to the mix bus. The balance control also affects the L-R balance within the mono sum sent to the Aux sends. The mono (C) bus is always fed directly with a mono sum of the stereo post-fader signal.

SOLO

The SOLO button provides a stereo PFL feed to the engineer's headphones or monitors, or triggers a destructive solo in place, depending on mode selection at the master section. The SOLO button can also be activated remotely from a VCA solo when assigned to a VCA group, giving Stereo AFL. Intercancel or additive soloing is possible, with or without input priority, and solos can be cleared with a single button press at the master section. The SOLO button also features automatic momentary operation, by pressing and holding for more than 0.5 seconds.

MUTE

The MUTE switch mutes the signal to all busses, including pre-fade Aux sends. The mute can also be activated by the mute group system, an SIP mute signal or a VCA mute signal. It is also possible to activate the mute by sending a MIDI note message into the console's MIDI Input. The same MIDI messages are transmitted when the mute switch is manually pressed. A preview mode allows editing and checking of mute groups without disturbing the audio passing through the desk, and mutes can be set 'Safe'.

SAFE/PREV LED

The SAFE/PREV LED is used to indicate Mute Safe mode or Preview mode. The channel is toggled in or out of Safe mode using the MUTE switch, after first engaging EDIT SAFES mode on the master fader panel. Preview status is indicated by flashing illumination, upon entering Preview mode from the master module, if the Mute is present in the previewed mute group.

VCA Assignment

Each channel can be assigned to any combination of 8 VCA subgroups, using the SOLO button on each channel, in conjunction with the VCA master SOLO switches in VCA Assign mode.

Once assigned to a VCA group, the channel's fader level, mute and solo button come under the control of the VCA master controls, but can still be operated locally. Assignments are displayed on the 8 LEDs next to each channel fader. The left and right VCAs in the stereo channel are automatically assigned as a pair to the required VCA group.

LED Input Metering

A 12-segment LED bar-graph meter next to the fader meters the stereo signal and displays the highest of left or right, at the stereo EQ output.



Outputs & Master

Group and Aux Outputs with Swap Facility

MH2 adopts the same operational philosophy as its bigger brother the MH3 to achieve flexible dual-purpose operation. This uses a reversible signal path which allows either the Group or the Aux output signal to be controlled by a linear fader, and have access to an insert point. For FOH applications, the Groups are required on faders for subgrouping duties, and the insert point allows external EQ or dynamics to be used on the group. The Aux sends in this application will be used for FX sends, so rotary master controls are appropriate. By pressing the recessed GRP/AUX ON FDR button, thereby changing it to AUX mode, the console is set up for stage monitor use, where the Aux output is controlled by the fader, and has use of the insert point for EQ insertion. Meanwhile the Group output is swapped to the rotary fader.

It is possible to swap the fader mode for each of the 8 outputs individually, allowing any combination of subgroups and monitor sends on faders. This flexibility is essential when doing monitor mixes from FOH.

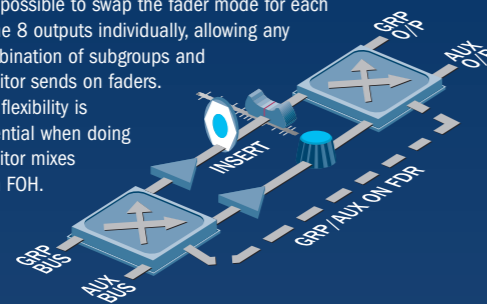

Fader Output Section

Each of the 8 fader master sections comprises a 60mm fader which feeds either the Group or Aux signals to their respective XLRs on the rear panel. A pre-fade balanced insert point, via separate 1/4" jacks, allows insertion of EQ and/or dynamics. Each fader knob is colour co-ordinated with its Aux bus send control for easy identification when controlling monitor mixes, and the 12-segment bargraph meter at the top of the section provides line-of-sight metering of any fader-controlled output. The TB button routes talkback or tone from the central talkback/oscillator section to whichever output is being controlled by the fader.

Illuminated MUTE and AFL SOLO buttons are provided for each fader. If stereo subgroups or in-ear sends are in use, the AFLs can be linked as a stereo pair by pressing both adjacent buttons at the same time; when linked, the AFL appears as a stereo AFL in the stereo wedge & phones outputs.

Rotary Output Section

Each of the 8 rotary master sections is equipped with a colour-coded rotary fader, and AFL SOLO and MUTE controls.

Group to Mix Section

The Group signal path, regardless of whether it is controlled by the fader or not, can always be routed to the main mix busses using the MIX and C switches and the PAN control.

Stereo FX Return with EQ

Located above each pair of Group/Aux output sections is a stereo FX return section (four in total). A stereo line input from balanced rear panel jacks is fed via a 0-10dB gain switch, via a stereo 3-band EQ section (see below) to a rotary level fader. Illuminated PFL and MUTE switches are provided.

The stereo return signal can be routed to the main MIX and C busses, auxes 9 & 10, or to the pair of output faders directly below the return. This gives a number of possible uses for the return in addition to that of a standard FX return to the main mix:

In monitor applications when Aux 9&10 may be feeding a stereo in-ear mix, the return can provide an individual reverb return for that mix only. Alternatively, if any of the 8 subgroups are not being used in a FOH application, the return can be routed to the output faders and then to mix, allowing control of the return level by linear faders.

The 3-band stereo EQ section comprises fixed shelving HF and LF bands, at 12kHz and 80Hz respectively, with a mid band fixed at 1kHz. 15dB of cut or boost is available on all bands.

Aux 9-10 Outputs Section with EQ

Aux outputs 9 & 10 have their own dedicated output section and are always controlled by linear faders. Each fader feeds the Aux signal to rear-panel XLR outputs, via a stereo 4-band EQ section. The EQ is designed for sweetening of in-ear monitor mixes, and comprises fixed frequency bands with shelving HF & LF and peak/dip mid bands. Each output has a pre-fade insert point with separate jacks, and TB, MUTE and AFL buttons are provided. The AFL buttons can be stereo linked if Aux 9-10 are being used as a stereo pair. The 12-segment LED bargraph meters at the top of the section normally meter the L and R Monitor outputs, but can be switched to meter the Aux 9-10 outputs by pressing the AUX 9-10 button below the meters.

Master Section

The master section contains the main L, R and C output faders, plus a sine wave test oscillator and internal talkback functions. This section also contains the monitor and headphone outputs, 2-track return and monitor source controls.

Main Output Faders

Three 100mm high quality faders control the stereo mix L, R and mono (C) mix output levels. These are fed to balanced XLRs on the rear panel. The C fader can be used to control the monitors level for feeding wedges in a stage monitor application by using the USE C FADER button in the monitor section.

Insert Points

Pre-fade MIX L, R and mono (C) insert points use balanced sends and returns on separate 1/4" jacks on the rear panel.

Matrix 1-4 Outputs Section

An 11x4 matrix section is located at the top right of the master section. Each of the 4 outputs has a rotary master fader with MUTE, AFL and TB buttons, and 11 receive knobs controlling the mix levels fed to that matrix output from each of the 8 Groups and the L,R and C main outputs. The matrix output signal itself appears on a rear panel XLR.

Talkback and Oscillator Section

The talkback and oscillator sections share a common set of TB routing buttons, allowing them to access any of the fader-controlled outputs and the matrix outputs. The talkback section has a front panel XLR for a dynamic mic input, with adjustable gain from 'off' to 50dB. The mic signal is routed to selected internal busses, by pressing the master TB button and the local TB button on the required output(s). The oscillator generates a variable frequency sine wave sweepable from 63Hz to 10kHz. It is routed to internal console busses by pressing both the OSC ON switch and the local TB switches on the desired output.

Monitor and Headphones Outputs

Separate level controls are provided for engineer's monitor speakers and headphones. The signal source for these outputs is common and can be selected from the post-fade MIX signal, the mono (C) MIX signal (to both L and R outputs), or the 2TK replay inputs, and may be summed by simultaneous selection if required. These sources are automatically overridden by an input or output solo signal. The level of the PFL signal only can be adjusted by ± 15 dB using the PFL TRIM control. The monitor level rotary control can be replaced with the centre output master fader, by pressing the USE C FADER button adjacent to the rotary control. The stereo monitor/phones signal can be summed to mono if required by pressing the MNO button and can be muted using the MUTE button. The headphones output socket is a stereo 1/4" jack, discretely mounted in a recessed socket in the fader panel fascia; the phones Volume control is located adjacent to the socket. Three 12-segment LED bargraph meters read the stereo and mono mix output levels. In the presence of a solo, the LR meters switch to show the solo signal. A clearly visible blue LED indicates the solo condition.

2-track Replay Input

For replay of stereo tape, CD or minidisc sources, a rotary level control adjusts the signal level from the balanced 1/4" jack stereo inputs. These can either be routed to the MIX bus with the MIX switch, or monitored on the monitor/phones outputs as described above.

Record Output

The rear panel contains two 1/4" jack outputs which are a buffered parallel feed from the Mix L & R Outputs. This can be used for recording or as another fixed-level mix bus feed.

PSU Status Indicators

Three red PSU Status LEDs indicate normal PSU rail operation.

Fader Panel Section

Solo Controls

The MH2 incorporates the same advanced solo system used in the MH3 and 4. The blue-illuminated SOLO CLEAR button not only gives unmistakable indication that a solo has been selected, but also allows any solo(s) on the console to be cancelled at the touch of a button. The Autocancel mode allows any solo button selected to cancel the previous solo, otherwise solos can be selected additively. Alternatively, pressing and holding any solo button for more than 0.5 seconds will result in automatic momentary operation of the switch.

Inputs normally solo as PFL, (with stereo inputs giving a stereo PFL) and outputs as mono or stereo AFL, but inputs can alternatively be soloed as stereo AFL (if assigned to a VCA group) by using the VCA master SOLO. The PFL trim control gives ± 15 dB of gain adjustment to the PFL signals fed to the monitor/phones outputs.

The INPUT PRIORITY button, when selected, allows an input solo to temporarily override any output solo which may be present. When the input solo is released, the original output solo will reappear on the monitors. The solo-in-place (SIP) enable button (which needs to be held for at least 2 seconds to activate it, for safety) selects 'destructive' in-place solo rather than mono PFL or stereo AFL. Group, Aux and Matrix output AFLs always remain in AFL mode, regardless of this switch setting. A VCA solo will perform a solo operation on all channels assigned to that VCA group, and give a stereo AFL solo. If SIP mode is engaged, the VCA solo will trigger a solo-in-place solo as if all member channels' solo switches had been pressed.



Fader Panel Section

VCA System & Mute Groups

The availability of VCA subgrouping has traditionally been associated with expensive consoles, but MH2 changes this, introducing a new level of sophistication to VCA grouping functionality in this class of console. Channels may be assigned to any of 8 VCA groups using the VCA ASSIGN master mode switch and the channel SOLO switches. Any VCA master then controls all the associated channel levels and their mutes and solos (although they can still be operated locally). The current status of all VCA assignments can be instantly and permanently viewed across the console with no button-pressing required, on the 8 VCA Assign LEDs clearly positioned by each input fader. Up to 6 mute groups can be created by setting the channel mutes required and pressing STORE and the required MUTE master button. These groups may then be recalled by the MUTE master buttons, and can be freely layered. To prevent inputs (eg. FX Returns) being muted by a mute group, VCA mute or a SIP solo, a SAFE mode can be activated for each channel using the EDIT SAFES function. This is indicated locally on each channel by a SAFE LED. A PREVIEW mode allows mute group assignment settings to be checked without actually muting any signal paths.

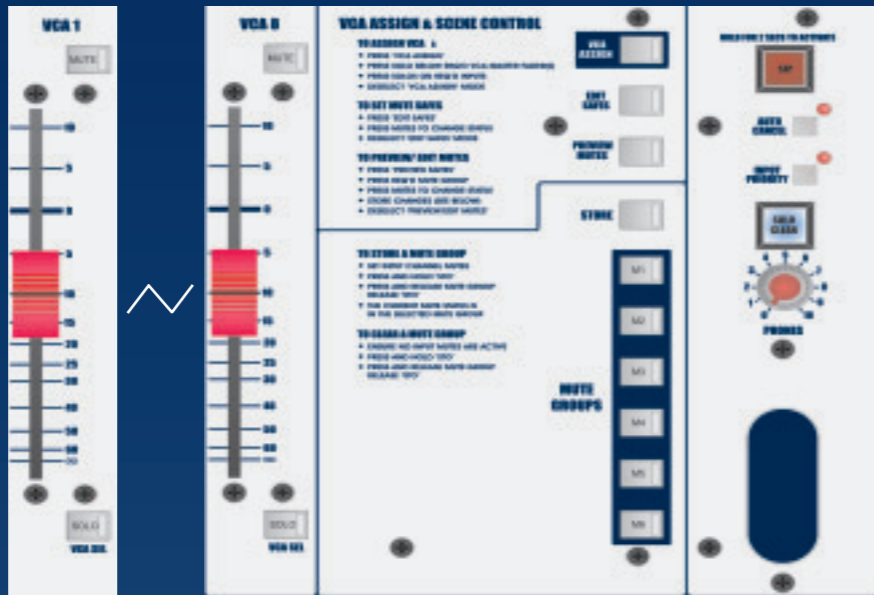

Mixing With VCAs

With the MH2, sophisticated VCA-style mixing at an affordable price is now a reality. VCAs - an abbreviation for Voltage Controlled Amplifiers - provide a convenient way of controlling complex groups of channels without ever having to stray too far from the central mixing position.

How They Work

A voltage is sent from a master fader to each member channel, where a VCA gain control element wired in series with the channel fader changes the level of all the grouped channels actually 'at source'. So although the faders don't actually move, the result is as if they have.

The Key Advantages (over Audio Groups)

- Stereo Groups need only 1 Group Fader (Audio Groups require 2)
- Shorter signal path - you don't have to route via an Audio Group then back to mix bus. Consequently, a better signal to noise ratio is achieved
- Post-fade FX sends are automatically turned up and down as you adjust the Group master, thus retaining wet/dry balance (with Audio Groups only the dry signal is affected)
- Using VCA Groups frees-up Audio Group faders, which can then be 'swapped' with Auxes for more flexibility in Monitor applications
- Groups within Groups can easily be set up - for example an overall band master controlling all channels can be created, as well as individual instrument groups
- Further advantages include remote control of channels, such as ability to solo or mute all channels in a group with one button press on the master

Integrated Control Of BSS Audio Varicurve™/ DBX Driverack™ 480

The MH2 continues the Soundcraft innovation of providing remote MIDI control of external system EQ from the output AFL switches - owners of BSS Audio Varicurve™ or dbx DriveRack™ 480 systems can automatically select the correct EQ page on the remote controller, corresponding to the soloed output channel. For Monitor applications, this allows slicker operation and less chance of adjusting the wrong output EQ.



PSU

All frame sizes of MH2 are supplied with an internal high-efficiency switched-mode Power Supply unit. The PSU is easily removable for ease of servicing on slide-out rails from the rear of the console, and incorporates automatic mains voltage switching to allow operation anywhere in the world. For additional peace of mind, the console is also fitted with a DC connector allowing connection of an additional external supply - the DPS-4, for use as redundant backup. When the DPS-4 is connected, it operates in parallel with the internal supply, with seamless switchover in the event of a failure of the internal unit. As a further alternative, two DPS-4's can be linked allowing redundant operation even if the console's internal PSU has been removed.



Configurations

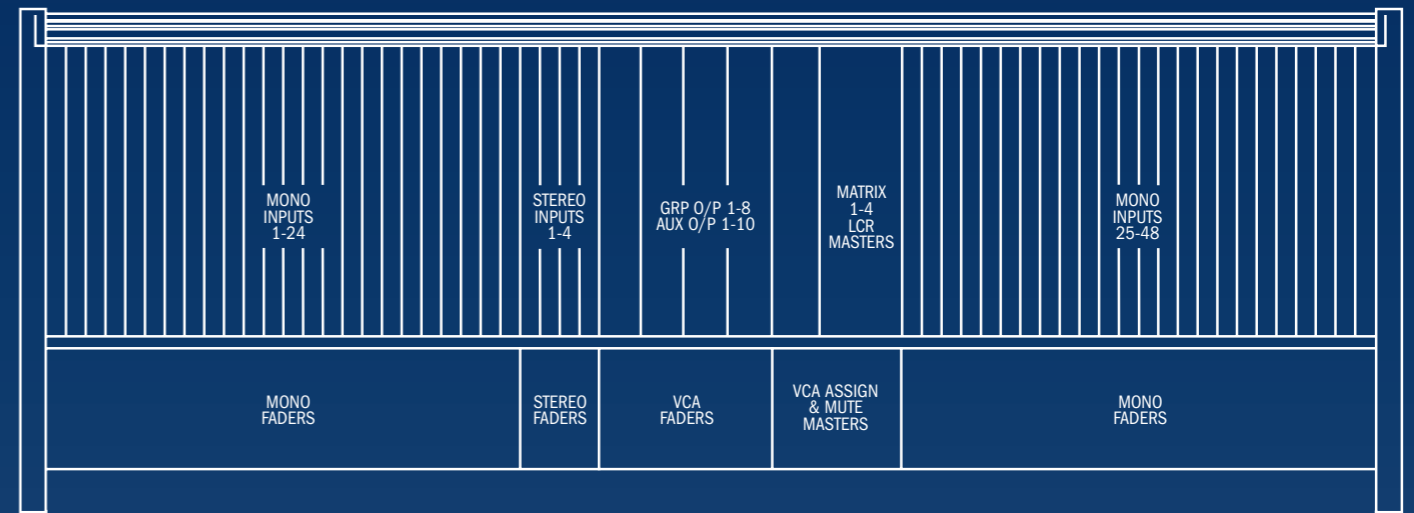

Rear Panel



Dimensions & Weight

Height	All frame sizes	256mm (10.0")
Width	24 Ch	1271mm (50.0")
	32 Ch	1509mm (59.4")
	40 Ch	1732mm (68.2")
	48 Ch	1956mm (77.0")
Depth	All frame sizes	753mm (29.7")
Weight	24 Ch	51 kg (113 lb)
	32 Ch	67 kg (147 lb)
	40 Ch	83 kg (183 lb)
	48 Ch	100 kg (220 lb)

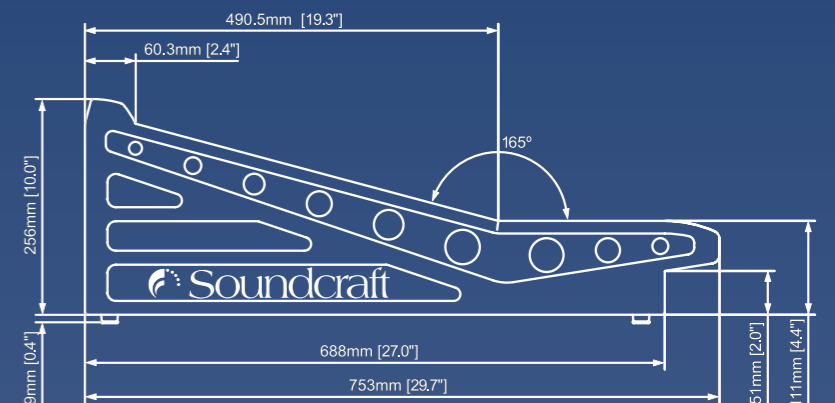

DPS-4 Power Supply Unit

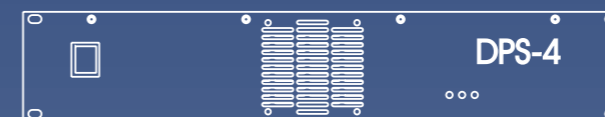

Height	2U - 89mm (3.5") (2 rack spaces)
Width	483mm (19")
Depth	245mm (9.65") (allow approximately 100mm/4" at rear for connector and cable clearance)

System Block Diagrams

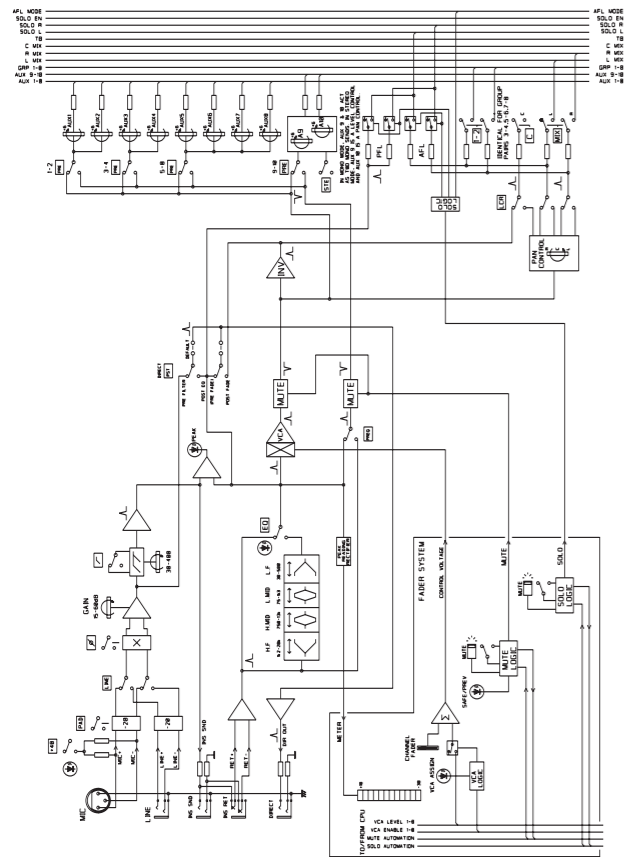

MONO INPUT

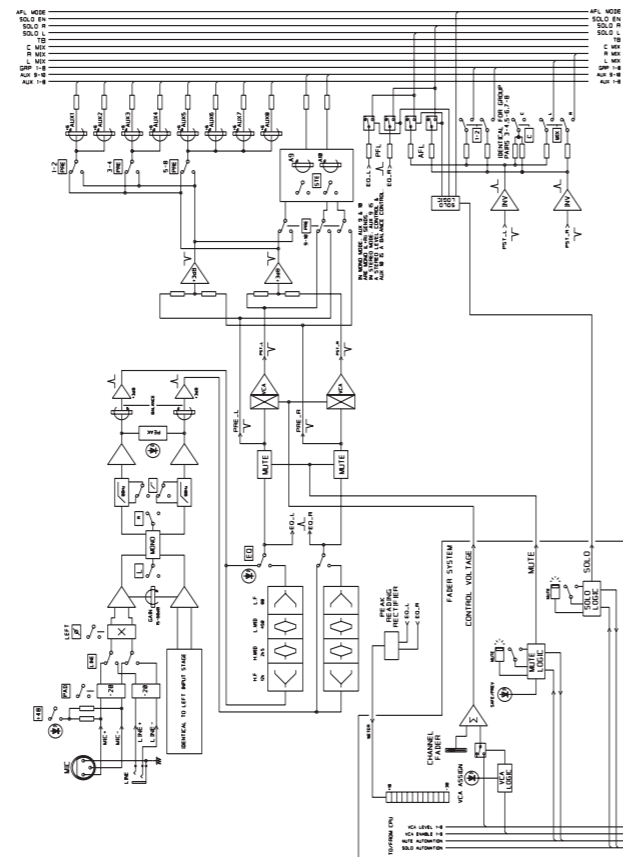

STEREO INPUT

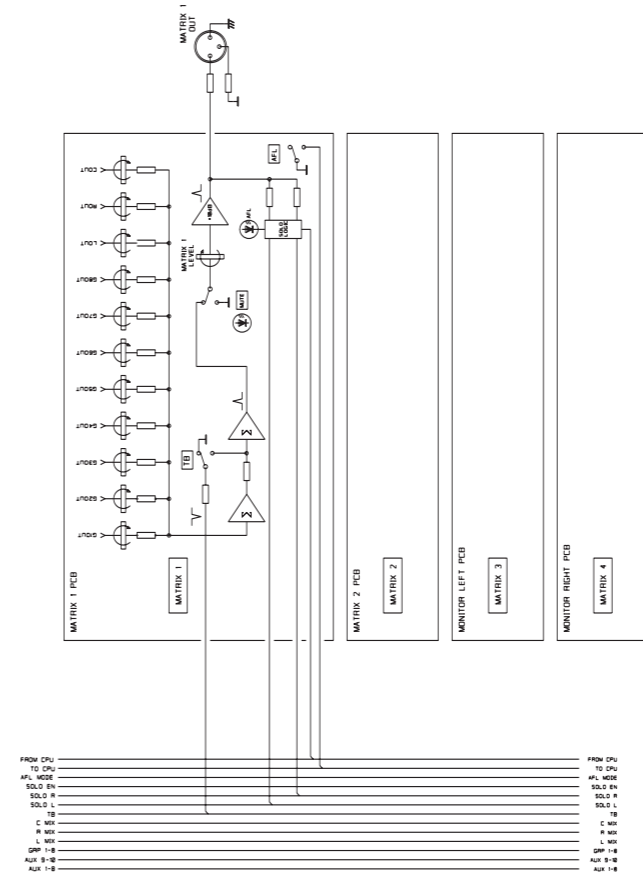

MATRIX

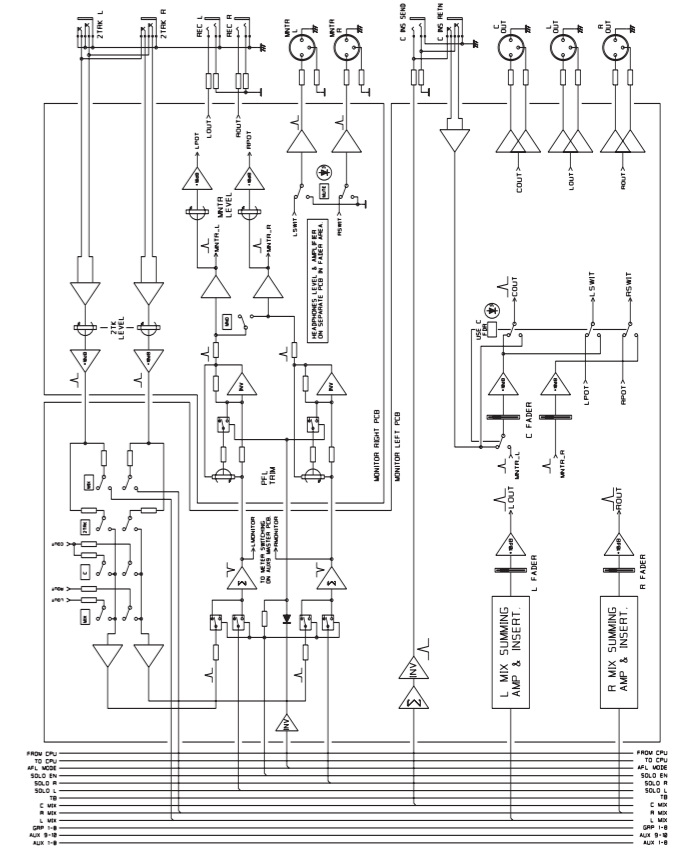

LCR MIX

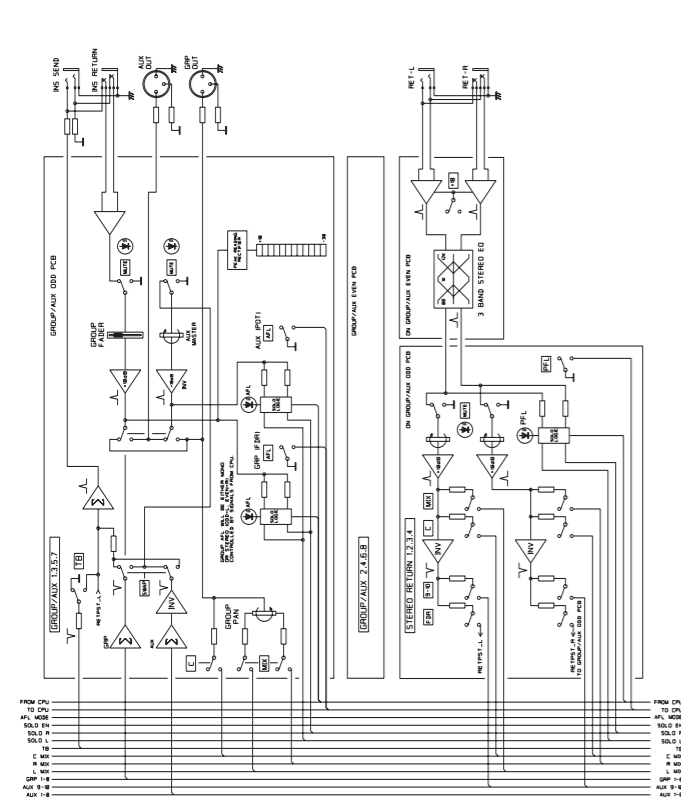

GROUPS & AUXES 1-8

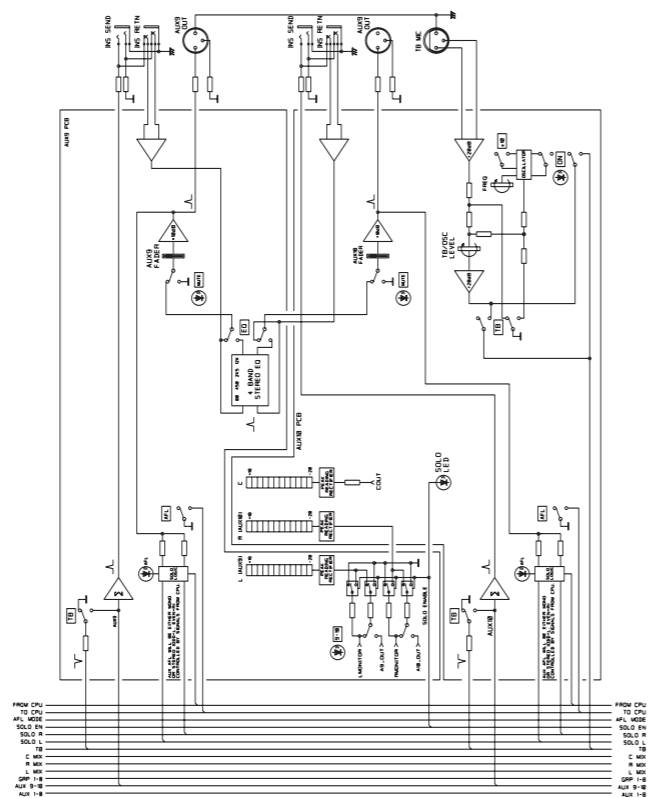

AUXES 9-10

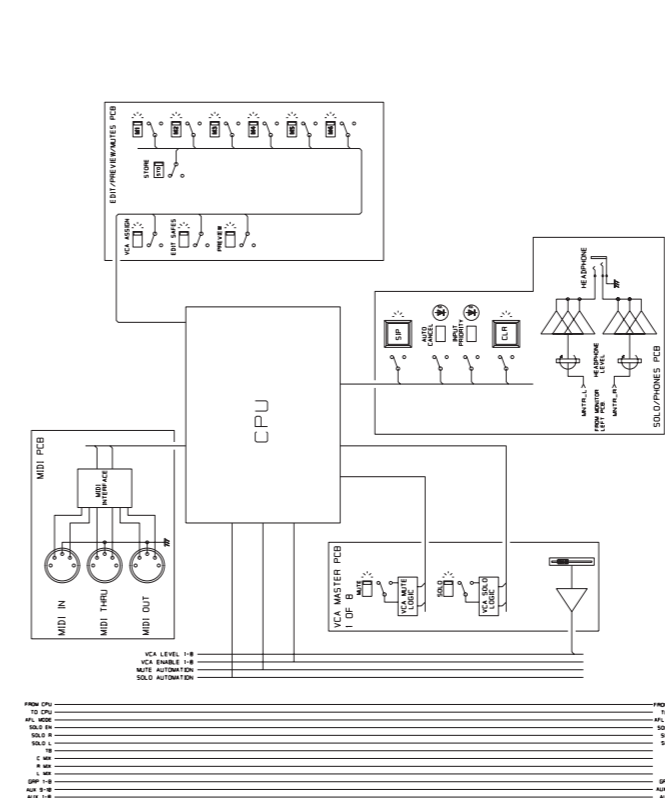

CPU