



DIGITAL PIANO

ARIUS

YDP-166

YDP-146

YDP-S56

YDP-S36

Owner's Manual

Thank you for choosing this Yamaha digital piano.
This instrument provides exceptionally high-quality sound and expressive control for your playing enjoyment. In order to make the most of the performance potential and features of the instrument, please read the manuals thoroughly, and keep them in a handy place for later reference.

Before using the instrument, be sure to read "PRECAUTIONS" on pages 4-5.
For information on assembling the instrument, refer to the instructions on page 37.

For United Kingdom

EN SIMPLIFIED EU DECLARATION OF CONFORMITY / SIMPLIFIED UK DECLARATION OF CONFORMITY

Hereby, Yamaha Corporation declares that the radio equipment type [YDP-166, YDP-146, YDP-S56, YDP-S36] is in compliance with Directive 2014/53/EU and the radio equipment regulations of UK. The full texts of the EU declaration of conformity and the UK declaration of conformity are available at the following internet address:
<https://europe.yamaha.com/en/support/compliance/doc.html>

(559-M01 RED DoC URL 03)

The model number, serial number, power requirements, etc., may be found on or near the name plate, which is at the bottom of the unit. You should note this serial number in the space provided below and retain this manual as a permanent record of your purchase to aid identification in the event of theft.

Model No.

Serial No.

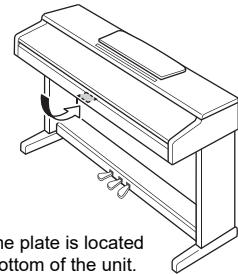

The name plate is located on the bottom of the unit.

(1003-M06 plate bottom en 01)

Important Notice: Power management information for customers in European Economic Area (EEA), Switzerland and Turkey

English

Yamaha products are equipped with a power management function. Some products allow you to disable that function, or to extend the amount of time that elapses before the power is turned off or set to standby. In these cases, energy consumption will increase.

(574-M06 EU erp 01)

PRECAUTIONS

PLEASE READ CAREFULLY BEFORE PROCEEDING

Especially in the case of children, a guardian should provide guidance on how to properly use and handle the product before actual use.

Please keep this manual in a safe and handy place for future reference.



WARNING

Always follow the basic precautions listed below to avoid the possibility of serious injury or even death from electrical shock, short-circuiting, damages, fire or other hazards. These precautions include, but are not limited to, the following:

Power supply

- Do not place the power cord near heat sources such as heaters or radiators. Also, do not excessively bend or otherwise damage the cord, or place heavy objects on it.
- Do not touch the product or the power plug during an electrical storm.
- Use only the correct voltage specified for the product. The required voltage is printed on the name plate of the product.
- Use only the supplied/power cord.
- Do not use the supplied AC adaptor/power cord for other devices.
- Check the power plug periodically and remove any dirt or dust which may have accumulated on it.
- Insert the power plug firmly all the way into the AC outlet. Using the product when it is not plugged in sufficiently can cause dust to accumulate on the plug, possibly resulting in fire or skin burns.
- When setting up the product, make sure that the AC outlet you are using is easily accessible. If some trouble or malfunction occurs, immediately turn off the power switch and disconnect the plug from the outlet. Even when the power switch is turned off, as long as the power cord is not unplugged from the wall AC outlet, the product will not be disconnected from the power source.
- Do not connect the product to an electrical outlet using a multi-plug outlet extender. Doing so can result in lower sound quality, or possibly cause fire at or around the outlet.
- When disconnecting the power plug, always hold the plug itself and not the cord. Pulling by the cord can damage it and cause electric shock or fire.
- If not using the product for long periods of time, be sure to pull the power plug from the AC outlet.

Do not disassemble

- This product contains no user-serviceable parts. Do not attempt to disassemble the internal parts or modify them in any way.

Water warning

- Do not expose the product to rain, use it near water or in damp or wet conditions, or place on it any containers (such as vases, bottles or glasses) containing liquids which might spill into any openings or places where water may drop. A liquid such as water getting into the product may cause fire, electric shock, or malfunctions.
- Use the AC adaptor indoors only. Do not use it in any wet environments.
- Never insert or remove a power plug with wet hands.

Fire warning

- Do not place any burning items or open flames near the product, since they may cause fire.

Wireless unit

- Radio waves from this product may affect electro-medical devices, such as a heart pacemaker implant or defibrillator implant.
 - Do not use the product near medical devices or inside medical facilities. Radio waves from this product may affect electro-medical devices.
 - Do not use the product within 15 cm (6 in.) of persons with a heart pacemaker implant or a defibrillator implant.

Using the bench (if included)

- Do not place the bench in an unstable and slippery position where it might accidentally fall over and cause injury.
- Do not play carelessly with or stand on the bench. Using it as a tool or stepladder or for any other purpose might result in accident or injury.
- Only one person should sit on the bench at a time, in order to prevent the possibility of accident or injury.
- Tighten the bench screws periodically using the specified tool. Failure to do so may cause the screws to loosen over time, and cause accident or injury.
- Keep special watch over any small children so that they don't fall off the rear of the bench. Since the bench does not have a backrest, unsupervised use may result in accident or injury.

If you notice any abnormality

- If any of the following problems occur, immediately turn off the power switch and disconnect the power plug from the outlet. Finally have the device inspected by Yamaha service personnel.
 - The power cord or plug becomes frayed or damaged.



CAUTION

Always follow the basic precautions listed below to avoid the possibility of physical injury to you or others, or damage to the product or other property. These precautions include, but are not limited to, the following:

Assembly

- Assemble the product in the proper sequence by following the assembly instructions in this manual. Also, make sure to tighten the screws or bolts regularly. Failure to do so might result in damage to the product or even injury.
- (YDP-S56, YDP-S36) Be sure to attach the anti-fall brackets to the product, to ensure stability (page 41). Failure to do so might result in damage to the product or even injury.

Location

- Do not place the product in an unstable position or a location with excessive vibration, where it might accidentally fall over, resulting in malfunction and even injury.
- Do not go near the product during an earthquake. Strong shaking during an earthquake could cause the product to move or tip over, possibly causing injury.
- When transporting or moving the product, always use two or more people. Attempting to lift the product by yourself may result in injuries, such as back injuries, or cause the product to be dropped and broken, which could lead to other injuries.
- Before moving the product, remove all connected cables, to prevent damage to the cables or injury to anyone who might trip over them.

Connections

- Before connecting the product to other devices, turn off the power for all devices. Before turning the power on or off for all devices, set all volume levels to minimum.
- Be sure to set the volumes of all devices at their minimum levels and gradually raise the volume controls while playing the product to set the desired listening level.

Handling

- Do not insert your finger or hand in any gaps on the key cover or product. Also take care that the key cover does not pinch your finger.
- Do not insert foreign materials such as metal or paper into any openings or gaps of the product. Failure to

- Unusual smells or smoke are emitted.
- Some object, or water has been dropped into the product.
- There is a sudden loss of sound during use of the product.
- Cracks or other visible damage appear on the product.

observe this may cause fire, electric shock, or malfunctions.

- (YDP-S56, YDP-S36) Do not apply excessive force when closing the key cover. A key cover equipped with the SOFT-CLOSE™ mechanism closes the cover slowly. Applying excessive force to the key cover when closing it could damage the SOFT-CLOSE™ mechanism, and possibly result in injury to your hands and fingers caught under the closing key cover.
- Do not rest your weight on, or place heavy objects on the product, and do not use excessive force on the buttons, switches or connectors.
- Keep small parts out of the reach of children, since they may accidentally swallow them.
- Do not use the product or headphones for a long period of time at a high or uncomfortable volume level, since this can cause permanent hearing loss. If you experience any hearing loss or ringing in the ears, consult a physician.
- Remove the power plug from the AC outlet before cleaning the unit. Failure to observe this may cause electric shock.

Using the bench (if included)

- For benches that can be adjusted, do not adjust the bench height while sitting on the bench, since this can cause excessive force applied to the adjustment mechanism, possibly resulting in damage to the mechanism or even injury.
- Do not place your hand between moving parts. Otherwise, your hand could be pinched between the parts, possibly resulting in injury.

Yamaha cannot be held responsible for damage caused by improper use or modifications to the product, or data that is lost or destroyed.

Always turn the power off when the instrument is not in use.

Even when the [⏻] (Standby/On) is in standby status (power lamp is off), electricity is still flowing to the instrument at the minimum level.

When you are not using the instrument for a long time, make sure you unplug the power cord from the wall AC outlet.

(DMI-12)

NOTICE

To avoid the possibility of malfunction/ damage to the product, damage to data, or damage to other property, follow the notices below.

■ Handling

- Do not use this product in the vicinity of a TV, radio, stereo equipment, mobile phone, or other electric devices. Otherwise, this product or the other device may generate noise.
- When you use the product along with an app on your smart device, such as a smartphone or tablet, we recommend that you enable “Airplane Mode” on the device to avoid noise caused by communication. When turning on airplane mode, **Bluetooth**® settings may be turned off. Make sure that the setting is turned on before use.
- Do not expose the product to excessive dust or vibrations, or extreme cold or heat (such as in direct sunlight, near a heater, or in a car during the day) to prevent the possibility of disfiguration, damage to the internal components or unstable operation. (Verified operating temperature range: 5° – 40°C, or 41° – 104°F.)
- Do not place vinyl, plastic or rubber objects on the instrument, since this might discolor the instrument.

■ Maintenance

- When cleaning the product, use a soft and dry (or slightly damp) cloth. Do not use paint thinners, solvents, alcohol, cleaning fluids, or chemical-impregnated wiping cloths.
- During extreme changes in temperature or humidity, condensation may occur and water may collect on the surface of the product. If water is left, the wooden parts may absorb the water and be damaged. Make sure to wipe any water off immediately with a soft cloth.

■ Saving data

- Some of the data of this product (page 34) are retained when the power is turned off. However, the saved data may be lost due to some failure, an operational mistake, etc.

Button names

The names of panel buttons are enclosed in square brackets []. Also, the word “button” is omitted throughout this manual (for example, the PLAY button is expressed as [PLAY]).

Information

■ About copyrights

- The copyright of the “content”^{*1} installed in this product belongs to Yamaha Corporation or its copyright holder. Except as permitted by copyright laws and other relevant laws, such as copying for personal use, it is prohibited to “reproduce or divert”^{*2} without the permission of the copyright holder. When using the content, consult with a copyright expert.
- If you create music or perform with the contents through the original use of the product, and then record and distribute them, the permission of Yamaha Corporation is not required regardless of whether the distribution method is paid or free of charge.

*1: The word “content” includes a computer program, audio data, Accompaniment Style data, MIDI data, waveform data, voice recording data, music score, and score data, etc.

*2: The phrase “reproduce or divert” includes taking out the content itself in this product, or recording and distributing it without changes in a similar manner.

■ About functions/data bundled with the product

- Some of the preset Songs have been edited for length or arrangement, and may not be exactly the same as the original.

■ About open source software

- The firmware of this product contains open source software. For copyright information and terms of use for each open source software, access the Yamaha website below:

Yamaha Downloads: <https://download.yamaha.com/>

■ About this manual

- The illustrations as shown in this manual are for instructional purposes only.
- Windows is a registered trademark of Microsoft® Corporation in the United States and other countries.
- The **Bluetooth**® word mark and logos are registered trademarks owned by Bluetooth SIG, Inc. and any use of such marks by Yamaha Corporation is under license.



- The company names and product names in this manual are the trademarks or registered trademarks of their respective companies.

■ Tuning

- Unlike an acoustic piano, this instrument does not need to be tuned by an expert (although the pitch can be user-adjusted to match other instruments). This is because the pitch of digital instruments is always maintained perfectly.

■ About disposal

- When disposing of this product, please contact the appropriate local authorities.

Table of Contents

PRECAUTIONS	4
About the Manuals	8
Included Accessories	8
Panel Controls and Terminals	9

Basic Operations

Setting Up	11
Key Cover (YDP-166, YDP-146).....	11
Music Rest (YDP-166, YDP-146).....	11
Key Cover and Music Rest (YDP-S56, YDP-S36)	12
Turning the Power On.....	13
Auto Power Off Function.....	14
Setting the Operation Confirmation Sounds.....	14
Volume Limiter Function	14
Using Headphones	15
Playing the Piano	16
Using Intelligent Acoustic Control (IAC)	16
Using the Pedals.....	17
Virtual Resonance Modeling Lite (VRM Lite) settings	18
Changing the Touch Sensitivity	18
Using the Metronome.....	19

Advanced Operations

Playing Various Musical Instrument Sounds (Voices)	20
Selecting a Voice	20
Listening to the Demo Songs	21
Adding Variations to the Sound (Reverb)	22
Transposing the Pitch in Semitones	23
Fine-tuning the Pitch	23
Layering Two Voices (Dual mode)	24
Playing Duo.....	25
Song Playback and Practice	26
Listening to Preset Songs.....	26
Practicing a One-Hand Part.....	27
Playing Back Immediately from the First Note (Quick Play)	27

Recording Your Performance	28
Recording Your Performance	28
Changing the Initial Settings of the Recorded Song	29
Deleting Recorded Data	29
Using with a Smart Device or a Computer	30
Playback/Recording of Audio Data (USB Audio Interface)	30
Listening to Audio via Bluetooth on this Instrument (Bluetooth Audio).....	31
Using the convenient Smart Pianist app.....	32

Backing up Data and Initializing the Settings	34
Data Maintained When Power is Turned Off.....	34
Initializing the Settings.....	34
Confirming the firmware version of this instrument.....	34

Appendix

Troubleshooting	35
Keyboard Stand Assembly	37
Assembly Precautions	37
Moving/Installing	37
YDP-166, YDP-146 Assembly.....	38
YDP-S56, YDP-S36 Assembly.....	41
Specifications	44
Index	46
Song List	47
Quick Operation Guide	at the end

About the Manuals

This instrument has the following documents and instructional materials.



Supplied with the instrument

- **Owner's Manual (this book)**

Explains the basic operations and functions of this instrument. Please read this manual first.



Available on the website

- **Quick Operation Guide**

Shows in chart form the functions assigned to the buttons and the keyboard for quick understanding.



https://manual.yamaha.com/mi/rt/ydp-166_s56/qg/

- **MIDI Reference**

Contains information about MIDI pertaining to this instrument.

- **Smart Pianist User Guide**

Explains how to set up and use the smart device app “Smart Pianist” (page 32) for controlling this instrument.



To obtain these manuals, access the website below. Enter the model name for searching the desired manuals.

Yamaha Downloads

<https://download.yamaha.com/>

* For a general overview of MIDI and how you can effectively use it, search for “MIDI Basics” (only in English, German, French and Spanish) on the website above.

Included Accessories

- Owner's Manual (this book) × 1
- “50 Classical Music Masterpieces” (music book) × 1
- Online Member Product Registration × 1
- AC adaptor × 1
- Power cord × 1 (YDP-166, YDP-S56)
- Bench* × 1 (YDP-166, YDP-146)

* May not be included depending on your particular area. Please check with your Yamaha dealer.

Panel Controls and Terminals

YDP-166, YDP-146

The illustration is YDP-146.

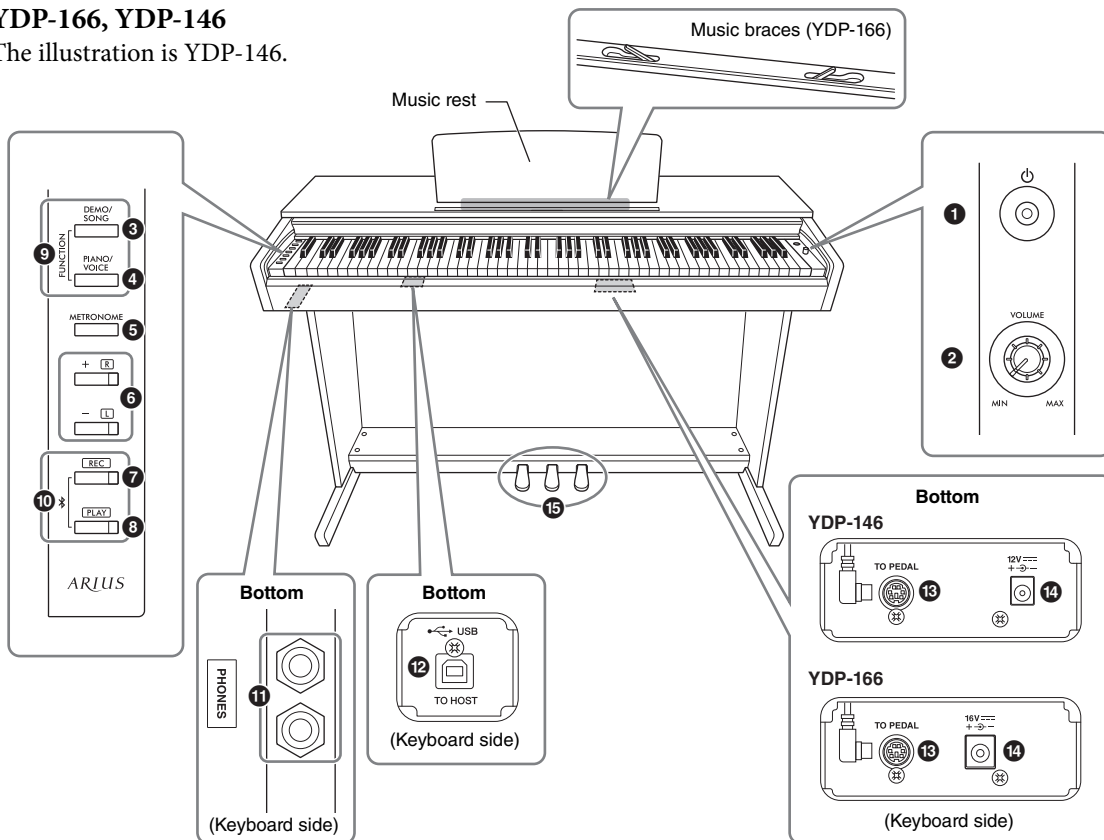

YDP-S56, YDP-S36

The illustration is YDP-S56.

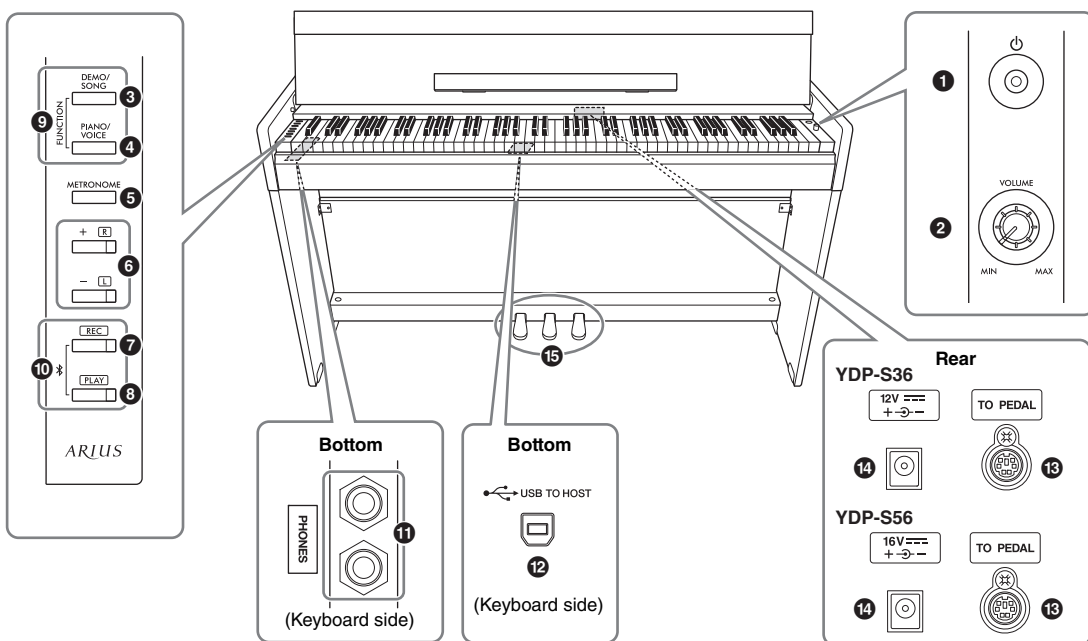

- ❶ [⏻] (Standby/On) switch..... page 13
For turning the power on or setting to standby.
- ❷ [VOLUME] knob..... page 13
For adjusting the volume of the entire sound.
Turning it to the right increases the volume, and turning it to the left decreases the volume.
- ❸ [DEMO/SONG] button..... pages 21, 26
For playing the Demo Songs and the Preset Songs (50 Classical Music Masterpieces, Lesson Songs).
- ❹ [PIANO/VOICE] button..... pages 20, 22, 24
For selecting a single Voice, two Voices for layering or a Reverb Type.
- ❺ [METRONOME] button..... page 19
For starting or stopping the metronome.
- ❻ [+R], [-L] buttons..... pages 19, 20, 26, 27
 - These are for increase or decrease Song numbers, tempo values, etc.
 - During Song playback, turning on/off the right-hand and left-hand Parts individually.
- ❼ [REC] button..... page 28
For recording your keyboard performance.
- ❽ [PLAY] button..... page 28
For playing back the recorded performance.
- ❾ [FUNCTION]..... pages 14, 23
Simultaneously holding both [DEMO/SONG] and [PIANO/VOICE] and pressing a specified key allows you to change various settings, including Auto Power off function, Transpose parameters, etc.
- ❿ [✳] Bluetooth Pairing..... page 31
Press and hold [REC] and [PLAY] simultaneously for three seconds to pair with a Bluetooth-enabled device such as a smartphone.
- ⓫ [PHONES] jacks..... page 15
For connecting a set of standard stereo headphones.
- ⓬ [USB TO HOST] terminal..... page 30
For connecting to a computer or a smart device.
- ⓭ [TO PEDAL] jack..... pages 39, 43
For connecting the pedal cord of the pre-installed pedal or the separately sold FC35 pedal unit.
- ⓮ DC IN jack..... page 13
For connecting the AC adaptor.
- ⓯ Pedals..... page 17
For controlling expression and sustain, just as on an acoustic piano.

Setting Up

Key Cover (YDP-166, YDP-146)

To open the key cover:

Lift the cover slightly, then push and slide it to the end.

To close the key cover:

Slide the cover toward you and gently lower the cover over the keys.

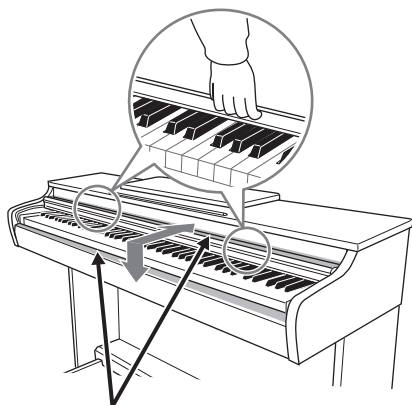

CAUTION

Be careful to avoid catching your fingers when opening or closing the cover.

CAUTION

- Hold the cover with both hands when opening or closing it. Do not release it until it is fully opened or closed. Be careful to avoid catching fingers (yours or others, especially children's) between the cover and main unit.
- Do not place objects, such as a piece of metal or paper, on top of the key cover. Small objects placed on the key cover may fall inside the unit when the cover is opened and may be nearly impossible to remove. This could cause electric shock, short circuit, fire or other serious damage to the instrument.

Music Rest (YDP-166, YDP-146)

To raise the music rest:

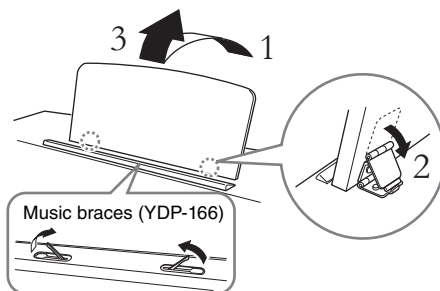

1. Pull the music rest up and toward yourself as far as it will go.
2. Flip down the two metal supports at the left and right on the rear of the music rest.
3. Lower the music rest so that the metal supports latch into place.

(YDP-166) Music braces allow you to hold the pages of music books in place.

CAUTION

Do not try to use the music rest in a half-raised position. When lowering the music rest, do not release your hands from the music rest until it is all the way down.

To lower the music rest:

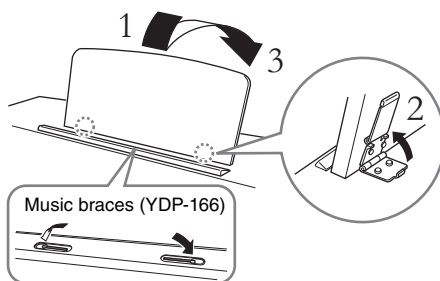

(YDP-166) Close the Music braces if they are open, and then lower the music rest by following the instructions below.

1. Pull the music rest toward yourself as far as it will go.
2. Raise the two metal supports (at the rear of the music rest).
3. Gently lower the music rest backward until it is all the way down.

Key Cover and Music Rest (YDP-S56, YDP-S36)

⚠ CAUTION

Hold the key cover with both hands when opening or closing it. Do not release it until it is fully opened or closed. Be careful to avoid catching fingers (yours or others, especially children's) between the key cover and main unit.

Opening the key cover

1. Hold the edge of the key cover top with both hands, then open the key cover slowly.
2. Fold down the front part of the key cover.

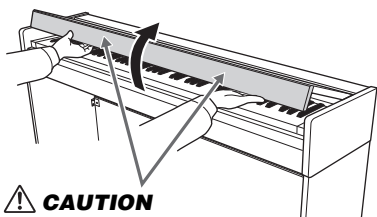

⚠ CAUTION

Be careful to avoid catching your fingers when opening the cover.

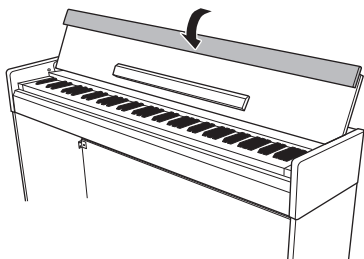

3. Unfold the music rest.

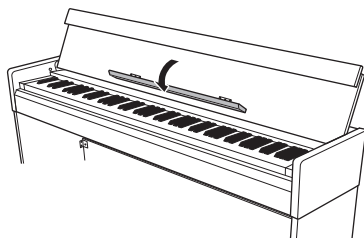

Closing the key cover

1. Fold the music rest.
2. Unfold the front part of the key cover.

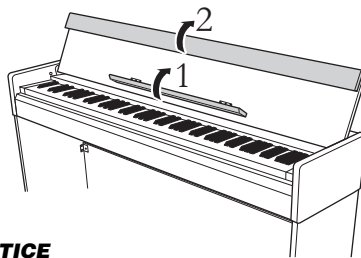

NOTICE

Before closing the key cover, be sure to fold the music rest and unfold the front part of the key cover.

3. Hold the key cover with both hands and close it slowly.

The key cover is equipped with the special SOFT-CLOSE™ mechanism which closes the cover slowly.

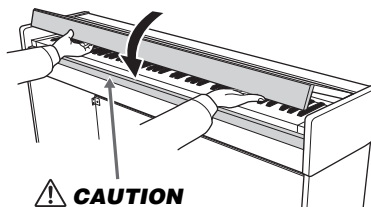

⚠ CAUTION

Be careful to avoid catching your fingers when closing the cover.

⚠ CAUTION

Do not apply excessive force when closing the key cover. Applying excessive force to the key cover when closing it could damage the SOFT-CLOSE™ mechanism, and possibly result in injury to your hands and fingers caught under the closing key cover.

Turning the Power On

1. Connect the plugs of the AC adaptor in the order shown in the illustration.

YDP-166, YDP-S56

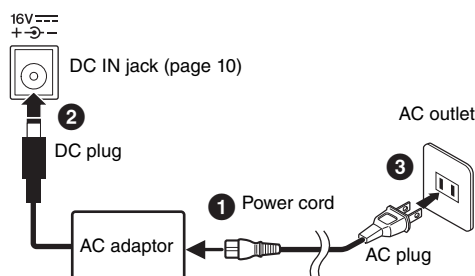

The shape of the plug and outlet differ depending on the locale.

YDP-146, YDP-S36

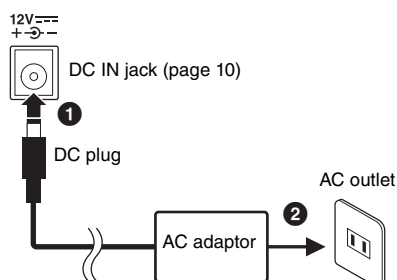

⚠ WARNING

- Use the specified adaptor (page 45) only. The use of other adaptors may result in irreparable damage to both the adaptor and the instrument.
- When setting up the product, make sure that the AC outlet you are using is easily accessible. If some trouble or malfunction occurs, immediately turn the power off and disconnect the plug from the outlet.

NOTE

Follow the order shown above in reverse when disconnecting the AC adaptor.

When using the AC adaptor with a removable plug

Do not remove the plug from the power adaptor. If it does come off, be careful not to touch the metal parts inside, and then plug it back in fully until you hear a click.

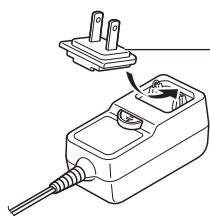

Plug

- Place the plug against the far side, and then firmly push it in until it clicks.
- The shape of the plug differs depending on your area.

⚠ WARNING

- When using an AC adaptor with a removable plug, make sure to keep the plug attached to the AC adaptor during use and storage. Inserting just the plug into an outlet can cause electric shock or fire.
- Never touch the inner metallic section of the plug to avoid electric shock, short circuit, or damage. If the plug comes off, push it in until it securely clicks in place. Also be careful that there is no dust or other foreign matter between the AC adaptor and plug.

2. Turn down the [VOLUME] knob to "MIN."

3. Press the [⏻] (Standby/On) to turn the power on.

The lamps on the buttons to the left of the keyboard light up, and when they go out, the instrument starts up.

The buttons to the left of the keyboard go from lit to unlit.

The power lamp lights up.

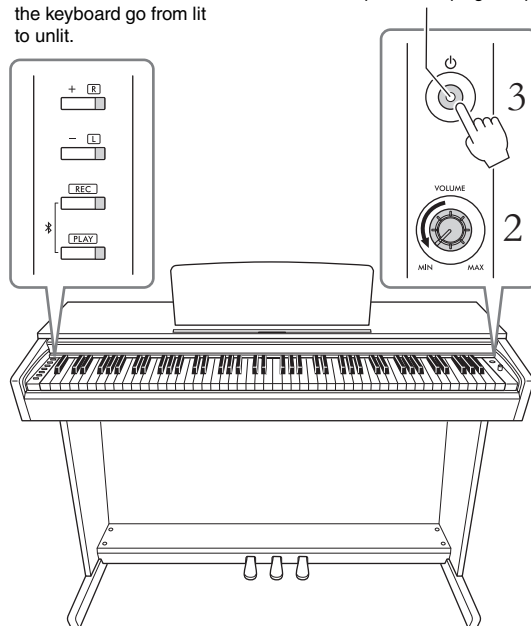

4. Press the [⏻] (Standby/On) again for 1 second to turn off the power.

The power indicator turns off.

⚠ WARNING

Even when the [⏻] (Standby/On) is in the standby status, electricity is still flowing to the instrument at a minimum level. When not using the instrument for an extended period of time, be sure to unplug the power cord from the wall AC outlet.

⚠ CAUTION

Do not use the instrument for a long period of time at a high or uncomfortable volume level, since this can cause permanent hearing loss.

NOTICE

Press only the [⏻] (Standby/On) when turning the power on. Any other operations, such as pressing the keys, buttons or pedals may cause the instrument to malfunction.

Auto Power Off Function

To prevent unnecessary power consumption, this instrument features an Auto Power Off function that automatically turns the power off if the instrument is not operated for approximately 15 minutes.

Toggle the Auto Power Off function (Enable/Disable)

While holding down [DEMO/SONG] and [PIANO/VOICE] simultaneously, press the A#0 key to enable the Auto Power Off function or the A0 key to disable it.

Default setting: Enabled

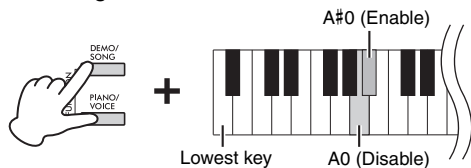

Quick disable of the Auto Power Off Function

You can also disable the function when turning on the power to the instrument.

While holding down the A-1 key (the lowest key), press the [⏻] (Standby/On) to turn the instrument on. The [REC] indicator flashes three times, indicating the Auto Power Off function has been disabled.

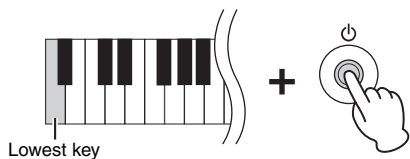

Setting the Operation Confirmation Sounds

When a setup is changed using a button and key combination, an operation sound (on, off, click, tempo value input) is sounded. This confirmation sound can be enabled (on) or disabled (off) as desired.

While holding down [DEMO/SONG] and [PIANO/VOICE] simultaneously, press the A#-1 key to turn the sounds on or the A-1 key to turn the sounds off.

Default setting: On

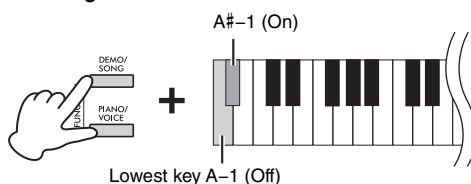

Volume Limiter Function

To prevent excessively loud volume, the Volume Limiter function can be used to limit the maximum volume. When the function is set to 20%, 50% or 80%, the volume will not increase beyond that point even if you turn the [VOLUME] knob to the right.

While simultaneously pressing [DEMO/SONG] and [PIANO/VOICE], press one of the keys F#6 (20%), G6 (50%), or G#6 (80%) as shown below to turn the function on, or press F6 to turn it off.

Default setting: Off

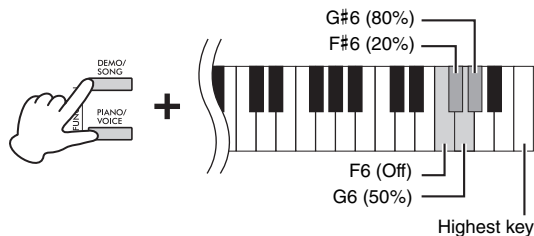

CAUTION

When you change the volume limit function setting, the sound may be output at a high volume depending on the position of the [VOLUME] knob. Be sure to set the [VOLUME] knob to the minimum (MIN) before changing the setting.

Using Headphones

Since this instrument is equipped with two [PHONES] jacks, you can connect two sets of standard stereo headphones.

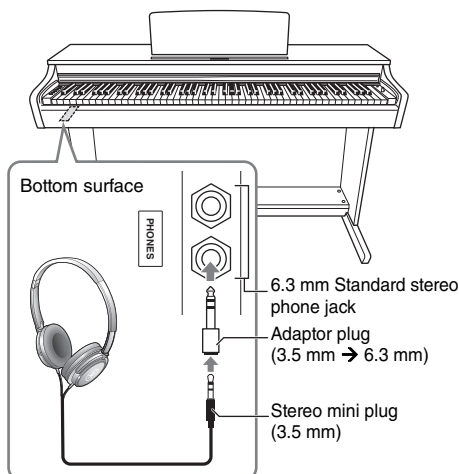

CAUTION

Do not use headphones at a high volume for an extended period of time; doing so may cause hearing loss.

NOTE

When a plug is connected to the [PHONES] jack, no sound will come out from the instrument's speakers. If you are using an adaptor plug, be sure to remove this as well when unplugging the headphones.

Using the headphone hanger (YDP-166)

You can hang the headphones on this instrument. For instructions on installing the headphone hanger, refer to "Keyboard Stand Assembly" on page 40.

NOTICE

Do not hang anything other than the headphones on the hanger. Doing so may damage this instrument or the hanger.

Speaker On/Off setting

You can set whether the sound of this instrument is always output from its built-in speaker or not. While holding down [DEMO/SONG] and [PIANO/VOICE] simultaneously, press one of the F5–G5 key.

Default setting: Normal

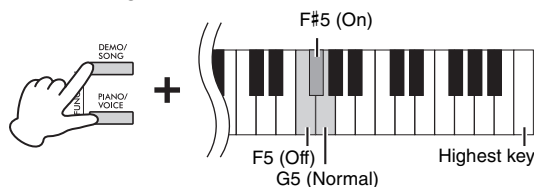

- **Off (F5):** The speaker will not sound.
- **On (F#5):** The speaker will always sound regardless of whether a set of headphones is connected or not.
- **Normal (G5):** The speaker will sound only if headphones are not connected. (This is the default setting.)

NOTE

Setting this to "On" disables the Stereophonic Optimizer (below).

Reproducing a natural sense of distance (Stereophonic Optimizer)

The Stereophonic Optimizer gives you the feeling of playing an actual acoustic piano—even though you're listening through headphones. Normally, the sound comes out from headphones sounds very close to your ears. However, this Stereophonic Optimizer effect recreates a natural distance or the sense of physical space between your ears and the instrument, just as when playing an acoustic piano.

Default setting: On

While holding down [PIANO/VOICE], press the F#3 key to turn the function on or the F3 key to turn the function off.

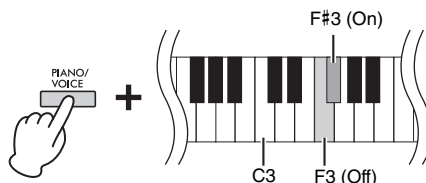

NOTE

- The Stereophonic Optimizer affects only Piano Voices (page 20).
- When the Speaker On/Off setting is on, the Stereophonic Optimizer is disabled.

Playing the Piano

Using Intelligent Acoustic Control (IAC)

IAC is a function which automatically adjusts and controls the sound quality according to the overall volume of the instrument. IAC Control is effective only on the sound output of the instrument speakers or headphones. Even when the volume is low, this lets you hear both low sounds and high sounds clearly. Especially when using the headphones, the burden on the ears is reduced without raising the overall volume excessively.

Default setting:

On

To turn on/off IAC:

While holding down [DEMO/SONG] and [PIANO/VOICE] simultaneously, press the C#2 key to turn the function on or the C2 key to turn the function off.

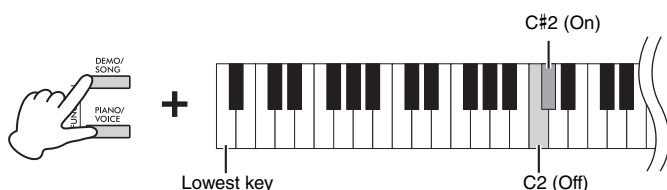

To adjust IAC Depth:

While holding down [DEMO/SONG] and [PIANO/VOICE] simultaneously, press the D2 key to decrease the value, or the E2 key to increase.

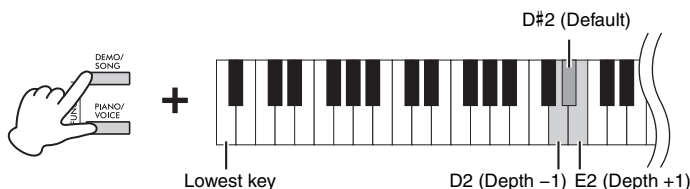

The higher the value, the more clearly that low and high sounds are heard at lower volume levels.

Setting range:

-3 - +3

Default setting:

0

Using the Pedals

Damper Pedal (Right)

Pressing this pedal will sustain notes longer. Releasing this pedal immediately stops (damps) any sustained notes. This pedal also features a “half-pedal” function that creates partial sustain effects, depending on how far down you press the pedal.

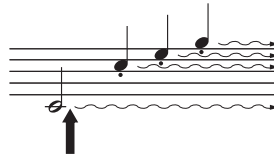

When you press the damper pedal here, the notes you play before you release the pedal have a longer sustain.

NOTE

If the damper pedal doesn't work, make sure that the pedal cord is properly plugged into the main unit (bottom of this page).

Half-pedal function

This function allows you to vary the sustain length depending on how far the pedal is pressed. The farther down you press the pedal, the more the sound sustains. For example, if you press the damper pedal and all notes you are playing sound a bit murky and loud with too much sustain, you can release the pedal half way or higher to decrease the sustain (murkiness).

Sostenuto Pedal (Center)

Pressing this pedal while holding the notes will sustain the pressed notes (as if the Damper Pedal had been pressed), but all subsequently played notes will not be sustained. This makes it possible to sustain a chord or single low note, for example, while the other notes are played “staccato.”

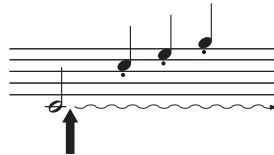

When you press the sostenuto pedal here while holding the note, the note will sustain as long as you hold the pedal.

NOTE

While the sostenuto pedal is held, the organ and strings Voices sound continuously without decay after the notes have been released.

Soft Pedal (Left)

Pressing this pedal will reduce the volume and slightly change the timbre of the notes. The notes played before this pedal is pressed are not affected.

NOTE

When Jazz Organ Voice (page 20) is selected, pressing the left pedal switches between fast/slow rotation of the rotary speaker. When the Vibraphone Voice (page 20) is selected, the left pedal switches Vibrato on and off.

[TO PEDAL] jack

Make sure to connect the plug of the pedal cord securely into the [TO PEDAL] jack in the proper direction. Otherwise, the pedal may not function properly. The FC35 Pedal Unit (sold separately) can also be connected to this terminal. You can substitute the FC35 for the pedals of the instrument, and use the pedals at a suitable height for you by placing the unit on a stand.

⚠ CAUTION

When placing the FC35 on a stand, make sure that the stand is sufficiently large, flat and stable to prevent the pedals from wobbling or falling when they are pressed.

NOTICE

Be careful to connect the plug in the proper direction. Connecting in the wrong direction can result in damage to the instrument.

NOTE

Make sure that power is off when connecting or disconnecting the plug of the pedal.

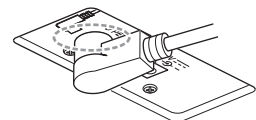

Insert the plug securely until the metal part of the plug disappears from view.

Virtual Resonance Modeling Lite (VRM Lite) settings

The VRM (Virtual Resonance Modeling) Lite technology featured in this instrument reproduces sophisticated string resonance faithfully using a virtual musical instrument (physical modeling), and makes the sound more like that of a real acoustic piano. Since instantaneous resonance is made at the moment according to the state of the keyboard or pedal, you can vary the sound expressively by changing the timing of your pressing the keys, and the timing and depth of your pressing the pedal. This function affects only to the Piano Voices (page 20).

To turn on/off the VRM Lite:

While holding [PIANO/VOICE], press the C#3 key to turn the function on or the C3 key to turn the function off.

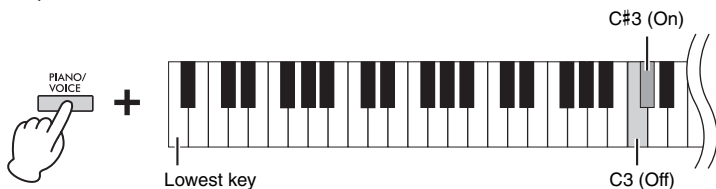

Default setting:
On

Changing the Touch Sensitivity

You can specify the Touch Sensitivity (how the sound responds to your playing strength). This setting does not change the weight of the keyboard.

While holding down [PIANO/VOICE], press one of the C6 – D#6 keys.

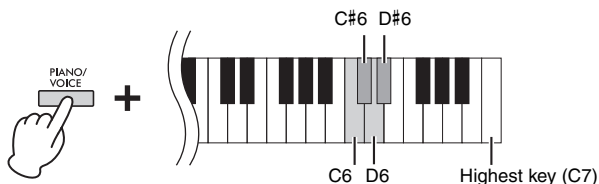

NOTE
This setting is disabled with some Voices, such as an organ sound.

Default setting:
C#6 (Medium)

Touch Sensitivity List

Key	Touch Sensitivity	Description
C6	Soft	Produces relatively high volume even with light playing strength.
C#6	Medium	Standard Touch Sensitivity.
D6	Hard	Requires strong playing to produce high volume.
D#6	Fixed	The volume level will be the same regardless of how hard you play the keys.

Using the Metronome

The metronome feature is convenient for practicing with an accurate tempo.

1. Press [METRONOME] to start the Metronome.
2. Press [METRONOME] to stop the Metronome.

Metronome setting

While holding down the [METRONOME], press one of the highlighted keys (shown below) or [+R]/[-L] to set the Metronome parameter.

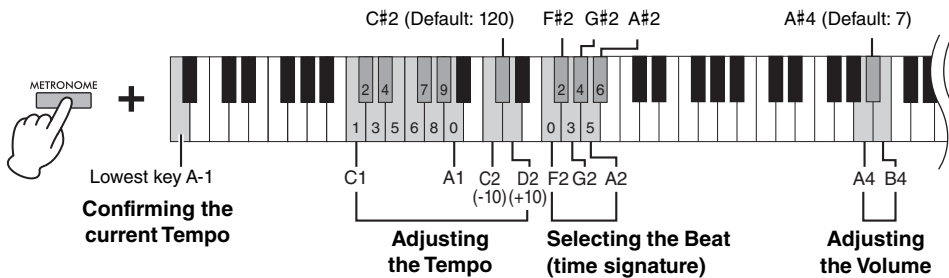

Voice confirmation of current Tempo value (in English)

While holding down [METRONOME], press the A-1 key (lowest key).

Adjusting the Tempo

The Metronome tempo can be set from 5 to 280 beats per minute.

- **To increase or decrease the value by 1:**

While holding down [METRONOME], press [+R] to increase or [-L] to decrease. While the metronome is playing, press [+R] to increase or [-L] to decrease.

- **To increase or decrease the value by 10:**

While holding down [METRONOME], press the D2 key to increase or the C2 key to decrease.

- **To specify a numeric value:**

While holding down [METRONOME], press the relevant C1 – A1 keys one by one in order. Specifying three digits or releasing [METRONOME] after specifying one or two digits will enter the value.

- **Resetting the value to the default (120)**

While holding down [METRONOME], press [+R] and [-L] simultaneously, or press the C#2 key. While the metronome is playing, press [+R] and [-L] simultaneously.

Selecting the Beat (time signature)

While holding down [METRONOME], press one of the F2 – A#2 keys. The first beat is accented with a bell sound and the rest with clicks. Default setting is 0 (F2). In this setting, clicks sound in all beats.

Adjusting the Volume

While holding down [METRONOME], press the B4 key to increase the volume or the A4 key to decrease. To reset to the default setting, press the A#4 key while holding down [METRONOME].

NOTE

Press the corresponding key and the number will be read out in English. If the entered value is outside the setting range, it will be ignored.

Key	Beat (time signature)
F2	0 (no accent)
F#2	2
G2	3
G#2	4
A2	5
A#2	6

Setting range:

1 – 10

Default setting:

7 (A#4)

Playing Various Musical Instrument Sounds (Voices)

Selecting a Voice

To select “CFX Grand”:

Simply press [PIANO/VOICE].

To select another Voice:

After pressing [PIANO/VOICE], press [+R] or [-L] to select the next or previous Voice.

To select a specific Voice:

While holding down [PIANO/VOICE], press one of the C1 – A1 keys. For details on which Voice is assigned to each key, see the list below.

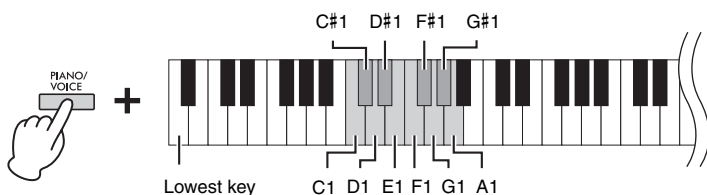

NOTE

To hear the characteristics of the Voices, play back the Demo Songs (page 21).

Voice List

Key	Voice Name	Voice description
C1	CFX Grand*	Yamaha’s CFX flagship concert grand piano sound with a wide dynamic range for maximum expressive control. Suitable for playing in any music genre and style.
C#1	Mellow Grand*	Grand piano sound with a soft and warm tone. Good for playing ballads.
D1	Pop Grand*	Bright piano sound. Good for clear expression and “cutting through” other instruments in an ensemble.
D#1	Stage E.Piano	The sound of an electric piano using hammer-struck metallic “tines.” Soft tone when played lightly, and an aggressive tone when played hard.
E1	DX E.Piano	An electronic piano sound created by FM synthesis. Good for standard popular music.
F1	Harpsichord	The definitive instrument for baroque music. Since harpsichord uses plucked strings, there is no touch response. There is, however, a characteristic additional sound when the keys are released.
F#1	Vibraphone	Vibraphone played with relatively soft mallets. The tone becomes more metallic the harder you play.
G1	Pipe Organ	This is a typical pipe organ sound (8’ + 4’ + 2’). Good for sacred music from the Baroque period.
G#1	Jazz Organ	The sound of a “tonewheel” type electric organ. Often heard in jazz and rock music.
A1	Strings	Stereo-sampled, large-scale strings ensemble with realistic reverb. Try combining this Voice with piano in the Dual mode.

*Piano Voices.

Listening to the Demo Songs

Special individual Demo Songs are provided for all of the instrument Voices.

1. Press [DEMO/SONG] to start playback.

The Demo Song for the current Voice starts. During playback, the [PLAY] lamp flashes at the current tempo.

Starting with the selected Song, the playback of the Demo Songs will continue.

After the last Demo Song, the sequence then returns to the first Demo Song and repeats until you stop it. To change to a specific Demo Song, simultaneously hold down [DEMO/SONG], and then press and hold one of the C1-A1 keys.

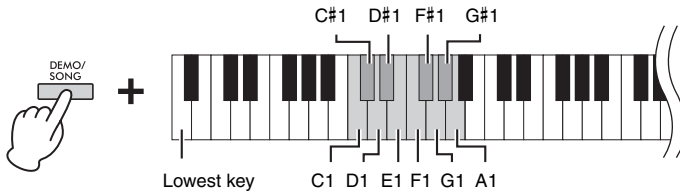

NOTE

The tempo can only be changed while the Demo Song is playing. If you want to change the playback tempo, see page 19.

To play back the selected Demo Song repeatedly:

While holding down the [DEMO/SONG], press and hold one of the C1-A1 keys. The operation sound (page 14) sounds twice and the Demo Song can be played back repeatedly.

To change the Demo Song during playback:

Press [+R] or [-L] to change to the next or previous Demo Song.

If you change to the next or previous Demo Song during repeated playback, that Demo song will also play back repeatedly.

2. Press [DEMO/SONG] or [PLAY] to stop playback.

The [PLAY] lamp turns off.

Demo Song List

Key	Voice Name	Title	Composer
C1	CFX Grand	Mazurka No.5 op.7-1	F. F. Chopin
C#1	Mellow Grand	The Nutcracker Medley	P. I. Tchaikovsky
D1	Pop Grand	Original	—
D#1	Stage E.Piano	Original	—
E1	DX E.Piano	Original	—
F1	Harpsichord	Concerto a cembalo obbligato, 2 violini, viola e continuo No.7, BWV 1058	J. S. Bach
F#1	Vibraphone	Original	—
G1	Pipe Organ	Herr Christ, der ein'ge Gottes-Sohn, BWV 601	J. S. Bach
G#1	Jazz Organ	Original	—
A1	Strings	Original	—

The length and actual content of the Demo Songs (excluding the original Songs) may differ from the original compositions. The original Demo Songs are Yamaha originals (© Yamaha Corporation).

Adding Variations to the Sound (Reverb)

This instrument features several Reverb Types that add extra depth and expression to the sound to create a realistic acoustic ambience. The appropriate Reverb Type and Depth are called up automatically when you select each of the Voices and Songs. This is why the Reverb Type need not be selected; however, you can change it if desired.

To select a Reverb Type:

While holding down [PIANO/VOICE], press one of the C2 – E2 keys.

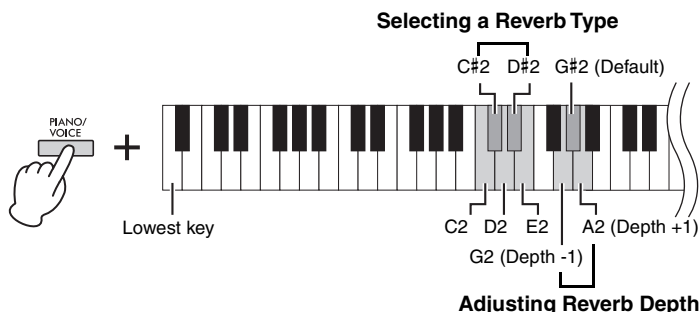

NOTE

In Dual Mode (page 24), an optimum reverb type for the combination of Voices is assigned automatically.

Reverb Type List

Key	Reverb Type	Description
C2	Recital Hall	Simulates the clear reverb sound you would hear in a medium-sized concert hall for piano recitals.
C#2	Concert Hall	Simulates the gorgeous reverb sound you would hear in a large concert hall for orchestral performances.
D2	Chamber	Suitable for playing chamber music; simulates the intimate reverb sound you would hear in a spacious room, such as for classical music recitals.
D#2	Club	Simulates the vivid reverb sound you would hear in a live music venue or a jazz club.
E2	Off	No effect is applied.

To adjust Reverb Depth:

The higher the value, the greater the depth, and the lower the value, the lesser the depth.

While holding down [PIANO/VOICE], press the G2 key to decrease the value by 1 or the A2 key to increase the value by 1.

While holding down [PIANO/VOICE], press the G#2 key to reset the Reverb Depth to the default setting, which is the most suitable value for the current Voice.

Setting range:

0 (no effect) – 20 (maximum depth)

Transposing the Pitch in Semitones

You can shift the pitch of the entire keyboard up or down in semitones in order to facilitate playing in difficult key signatures, or to easily match the pitch of the keyboard to the range of a singer or other instruments. For example, if “+5” is selected, playing key C produces pitch F, letting you play a song of F major as though it were in C major.

To transpose the pitch down:

While holding down [DEMO/SONG] and [PIANO/VOICE], press a key between F#2 (-6) and B2 (-1).

To transpose the pitch up:

While holding down [DEMO/SONG] and [PIANO/VOICE], press a key between C#3 (+1) and F#3 (+6).

To restore the normal pitch:

While holding down [DEMO/SONG] and [PIANO/VOICE], press the C3 key.

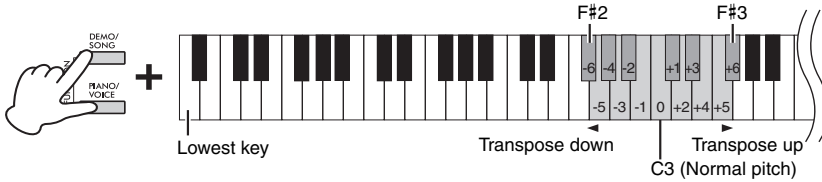

NOTE

The transposition setting affects not only the pitch of the keyboard but also the pitch of Song playback (page 26). The transposition setting of the Transposition for the Keyboard and the Song cannot be set independently.

Setting range:
-6 - 0 +6

Default setting:
0

Fine-tuning the Pitch

You can fine-tune the pitch of the entire instrument in about 0.2 Hz steps. This lets you accurately match the keyboard pitch to that of other instruments or ensembles.

To tune up (in about 0.2 Hz steps):

Press and hold down [DEMO/SONG] and [PIANO/VOICE] simultaneously, and press [+R].

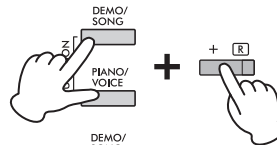

To tune down (in about 0.2 Hz steps):

Press and hold down [DEMO/SONG] and [PIANO/VOICE] simultaneously, and press [-L].

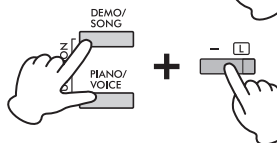

To set the pitch to 442.0 Hz:

Press and hold down [DEMO/SONG] and [PIANO/VOICE] simultaneously, and press the C#1 key.

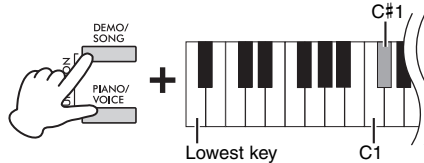

To restore default pitch (440.0 Hz):

While simultaneously holding down [DEMO/SONG] and [PIANO/VOICE], press [+R] and [-L] simultaneously. Alternately, you can press the C1 key while holding down [DEMO/SONG] and [PIANO/VOICE] simultaneously.

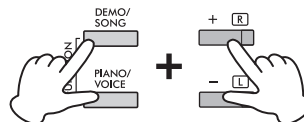

Hz (Hertz)

This unit of measurement refers to the frequency of a sound and represents the number of times a sound wave vibrates in a second.

Setting range:
414.8 - 466.8 Hz

Default setting:
A3 = 440.0 Hz

Layering Two Voices (Dual mode)

You can layer two Voices and play them simultaneously to create a more richly textured sound.

1. Engage the Dual mode.

While holding down [PIANO/VOICE], simultaneously hold down two keys between C1 and A1 to select the two desired Voices. For information on which Voices are assigned to the keys, refer to “Voice List” (page 20).

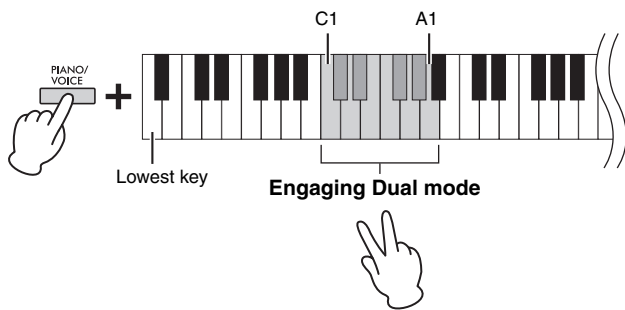

The Voice assigned to the lower key will be designated as Voice 1, and the Voice assigned to the higher key will be designated as Voice 2. You cannot assign the same Voice to both Voice 1 and Voice 2 simultaneously in Dual mode.

To shift the Octave for each Voice:

While holding down [PIANO/VOICE], press one of the keys F5 – G5 or A5 – B5 as shown in the illustration below. For example, pressing the B5 key twice while holding down [PIANO/VOICE] shifts Voice 1 up by two octaves. To restore the default setting, simultaneously hold down [PIANO/VOICE] and press the A#5 key for Voice 1 or the F#5 key for Voice 2.

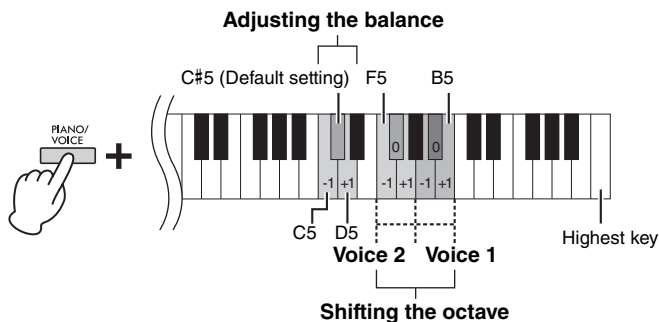

To adjust the Balance between two Voices:

While holding down [PIANO/VOICE], press the C5 key to decrease the value or the D5 key to increase. When the value is set to “0,” the volume levels of the two Voices reset to their respective default settings. Settings below “0” increase the volume of Voice 2, while settings above “0” increase the volume of Voice 1, in relation to the other.

2. To exit from Dual mode, press [PIANO/VOICE].

NOTE

The Dual and Duo modes (page 25) cannot be engaged at the same time.

Setting range:

-2 - 0 +2

Setting range:

-6 - (Default Setting) - +6

Default setting:

Differs depending on the Voice combination.

Playing Duo

This function allows two different players to play the instrument, one on the left and the other on the right, over the same octave range.

1. While holding down [PIANO/VOICE], press [+R] and [-L] simultaneously to engage Duo.

The keyboard is divided into two sections, with the E3 key as the Split Point.

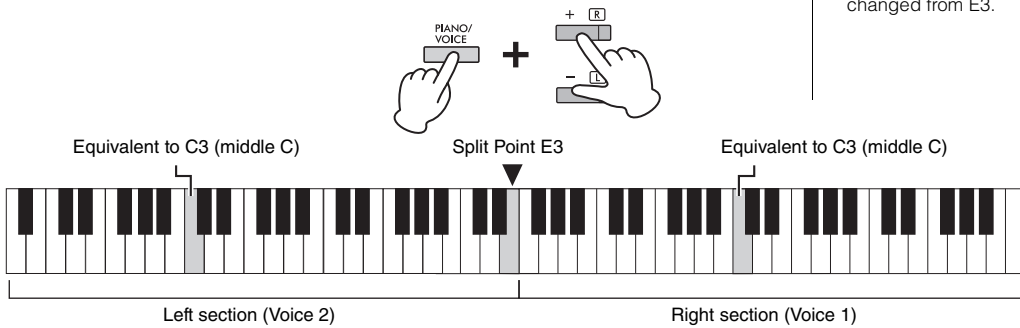

NOTE

- Different Voices cannot be assigned to the Right Voice and Left Voice.
- The Split Point cannot be changed from E3.

2. One person can play the left section of the keyboard while the other plays the right.

To shift the Octave for each section:

Same operation as in Dual (page 24).

In Duo, the left section is assigned to Voice 2, while the right section is assigned to Voice 1.

To adjust the volume balance between two keyboard sections:

Same operation as in Dual (page 24).

Settings below “0” increase the volume of Left Voice (Voice 2), while settings above “0” increase the volume of Right Voice, in relation to the other.

Pedal function in Duo

- Damper Pedal: Applies Sustain to the right section.
- Sostenuto Pedal: Applies Sustain to both sections.
- Soft Pedal: Applies Sustain to the left section.

To select the Duo Type:

You can set how the sound is emitted from the speakers.

- Separated: The sound of the left section is emitted from the left speaker, and the sound of the right section is emitted from the right speaker.
- Balanced: The sound of both parts are emitted from both speakers in a natural balance.

While holding down [PIANO/VOICE], press the A4 key or the A#4 key to change the setting.

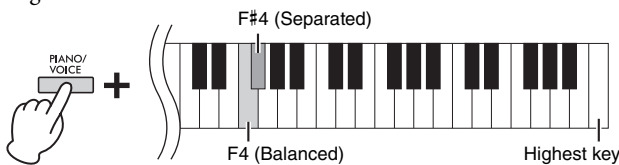

Setting range:

-2 - 0 - +2

Setting range:

-6 - 0 - +6

NOTE

The way the sound is output from the headphones is the same as the selected Duo Type.

NOTE

- If the keyboard is in Dual, engaging Duo will exit from Dual. Voice 1 is used as the Voice of the entire keyboard.
- In Duo, VRM Lite is not effective. When the Type of Duo is set to “Separated,” Reverb and Stereophonic Optimizer are not effective.

Default Setting:

Separated

3. To exit from Duo, while holding down [PIANO/VOICE], press [+R] and [-L] simultaneously.

Song Playback and Practice

Listening to Preset Songs

In addition to the Demo Songs, Preset Songs (50 Classical Music Masterpieces and Lesson Songs) are provided for your listening pleasure.

1. Check the song number and songbook.

For the details on the Music book and Song number, refer to the Song List (page 47) or Quick Operation Guide (page 52).

2. While holding down [DEMO/SONG], press one of the C0–G#0 keys to select a Music book.

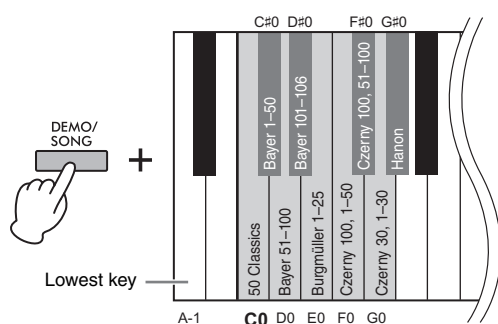

3. While holding down [DEMO/SONG], press one of the C2–C#6 keys to start playback.

The number of each piano Preset Song is assigned to the C2–C#6 keys.

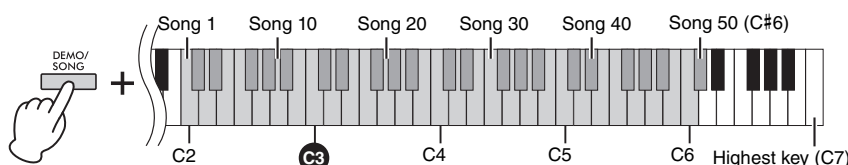

During playback, the [+R] and [–L] lamps light, and the [PLAY] lamp flashes at the current tempo. Playback of the Preset Songs continues in sequence, starting with the selected Song. After the last Preset Song, the sequence then returns to the first Preset Song and repeats until you stop it.

To play back the selected Song repeatedly:

While holding down the [DEMO/SONG], press and hold one of the C2–C#6 keys. The operation sound (page 14) sounds twice and the selected Song can be played back repeatedly.

To change the Preset Song during playback:

Press [+R] or [–L] to change to the next or previous Preset Song. If you change to the next or previous Preset Song during repeated playback, that Preset song will also play back repeatedly.

To change the tempo during playback:

While holding down [METRONOME], press [+R] or [–L] to increase or decrease the Tempo value by 1. Other instructions are the same as those of the Metronome Tempo (page 19).

Default Setting (Music book):

50 Classical Music Masterpieces (50 Classics)

NOTE

Once you change the Music book, the setting will be retained until the power is turned off.

NOTE

- You can play the keyboard along with the playback of the Preset Song as well as change the Voice played from the keyboard.
- Depending on the selected Music book, there are some keys to which the Song are not applied. When pressing such keys, no Songs are played back.

To play back from the beginning of the Song

During playback, press [+R] and [-L] simultaneously to jump to the playback position at the beginning of the Song then continue playback at the last specified tempo.

4. Press [DEMO/SONG] or [PLAY] to stop playback.

The [PLAY], [+R] and [-L] lamps turn off.

Practicing a One-Hand Part

All the Songs except for the Demo (page 21) let you turn on or off the left-hand and right-hand Parts individually. By turning off [+R], for example, you can practice the right-hand Part while the left-hand Part is playing back, and vice versa.

1. Start playback of the Preset Songs (page 26; 50 Classical Music Masterpieces and Lesson Songs) or the User Song (page 28).**2. While holding down [PLAY], press [+R] or [-L] to turn the Part off.**

Pressing the same button repeatedly while holding down [PLAY] toggles playback on and off.

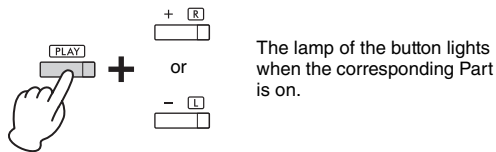
**NOTE**

- Selecting another Song will reset the on/off status.
- For the details on the Parts of the duet Songs, refer to page 47.
- For the User Song, Parts can only be independently turned on or off when recording the right or left part independently (step 2, page 29).

3. Practice the Part which is turned off.**To change the Tempo:**

If desired, you can change the tempo for your practice convenience. For details, refer to page 19.

4. Press [PLAY] to stop playback.**Playing Back Immediately from the First Note (Quick Play)**

This Quick Play feature enables you to specify whether a Song should play back immediately from the very first note (On), or play back any silence or rests that exist before the first note (Off).

To turn on/off Quick Play:

While holding down [DEMO/SONG], press the A[#]-1 to turn the function on or A-1 key to turn the function off.

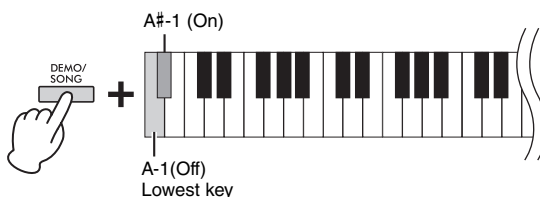
**Default setting:**

On

Recording Your Performance

This instrument lets you record your keyboard performance as the User Song. Up to two Parts (left-hand and right-hand) can be recorded separately.

Recording Your Performance

1. Select the desired Voice and other parameters, such as beat (time signature), for recording.

For instructions on selecting a Voice, refer to page 20. If necessary, set other parameters, such as beat (time signature) and effects, in this step.

2. Engage the Record Ready mode.

Quick Recording

Press [REC] to engage the Record Ready mode. Your keyboard performance will be automatically recorded to the right-hand Part even if you play with both your right and left hands. Note that the already-recorded data of the right- and left-hand parts will be erased by Quick Recording.

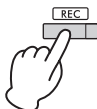

Recording to individual parts

While holding down [REC], press [+R] or [-L] to engage the Record Ready mode for the Part you want to record.

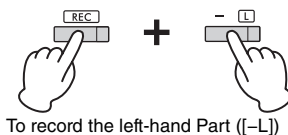
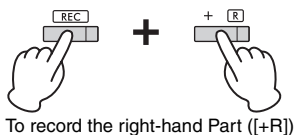

If data has already been recorded to the other Part, the data in this Part will be played back while recording.

To turn the Part off or on, press the appropriate part button ([+R] or [-L]) while holding down [PLAY].

To exit from Record Ready mode:

Simply press [REC].

3. Play the keyboard or press [PLAY] to start recording.

The [REC] lamp lights up while the Recording Part lamp flashes at the current tempo.

4. Press either [REC] or [PLAY] to stop recording.

The [REC], [PLAY], [+R] and [-L] lamps flash, indicating that the recorded data is being stored. After the Save operation is completed, the lamps will turn off, indicating that the Record operation has been completed.

5. To hear the recorded Song, press [PLAY] to start playback.

Press [PLAY] again to stop playback.

To record to the other part

Repeat the steps above. In step 2, follow the instructions of "Recording individual parts."

NOTICE

Only one Song can be recorded to the instrument. Note that recording another Song will replace already-recorded data with the new data.

NOTE

- The "Smart Pianist" app (page 32) enables you to record your keyboard performance as MIDI/audio data and save it on your smart device.
- You can use the Metronome while recording; however, the Metronome sound will not be recorded.
- If the keyboard is in the Duo mode (page 25), the data will be recorded to each Part. The Part for recording cannot be specified.
- If the data capacity of the instrument approaches full when you engage Record Ready mode, the [REC] and [PLAY] lamps flash quickly for about three seconds.

NOTICE

Note that recording your performance to a part containing data will replace already-recorded data with the new data.

NOTICE

Never turn off the power while the recorded data is being stored (while the lamps are flashing). Otherwise, all recorded data will be lost (page 34).

Recording Capacity

This instrument can record up to approximately 11,000 notes.

Changing the Initial Settings of the Recorded Song

The settings of the following parameters can be changed after the Record operation is completed.

- For individual Parts: Voice (page 20), Dual Volume balance (page 24), Reverb Depth (page 22)
- For the entire Song: Tempo (page 19), Reverb Type (page 22)

- 1. Make settings for the above parameters as desired.**
- 2. While holding down [REC], press the desired Part ([+R] or [-L]) to engage Record Ready mode.**

The [REC], [PLAY] and selected Part lamps flash.

In this status, do not press [PLAY] again or any key. Otherwise, the originally recorded performance data will be deleted.

- 3. While holding down [REC], press [PLAY] to exit from Record Ready mode.**

The [REC], [PLAY], [+R] and [-L] lamps flash. After the Save operation is completed, the lamps will turn off, indicating that the operation has been completed.

Confirm the setting by pressing [PLAY] to play the Song.

Deleting Recorded Data

To delete the entire Song:

- 1. While holding down [REC], press [DEMO/SONG].**

The [REC] and [PLAY] lamps flash alternately.

To cancel the operation, press [REC].

- 2. Press [PLAY] to delete the data of the entire Song.**

The [REC], [PLAY], [+R] and [-L] lamps flash.

After the operation is completed, all lamps turn off.

To delete a specific Part:

- 1. While holding down [REC], press [+R] or [-L] (depending on the Part you want to delete) to engage Record Ready mode.**

The [REC], [PLAY] and selected Part ([+R] or [-L]) lamps flash.

- 2. Press [PLAY] to start recording without playing the keyboard.**

The selected Part ([+R] or [-L]) lamp flashes.

- 3. Press [REC] or [PLAY] to stop recording.**

All data recorded for the selected Part will be deleted, and the lamp turns off.

NOTE

If a User Song has not been recorded to the instrument, the [REC] and [PLAY] lamps flash quickly for about three seconds.

Using with a Smart Device or a Computer

By connecting the instrument to a smart device such as a smartphone or tablet, or to a computer, you can exchange performance information (MIDI data/audio data). Connect to a smart device or computer using a USB cable or Bluetooth. You can connect the instrument to a smart device or a computer via a USB cable or Bluetooth.

NOTICE

Do not place any devices in an unstable position. Doing so may cause the device to fall and result in damage.

NOTE

For instructions on using MIDI, refer to "MIDI Reference" (page 8).

Playback/Recording of Audio Data (USB Audio Interface)

By connecting a smart device or a computer to the [USB TO HOST] terminal via a USB cable, digital audio data can be received/transmitted. You can listen to audio data played on the connected device through the instrument speaker, or you can record your performance on the instrument as audio data by using a music production software or app.

Example

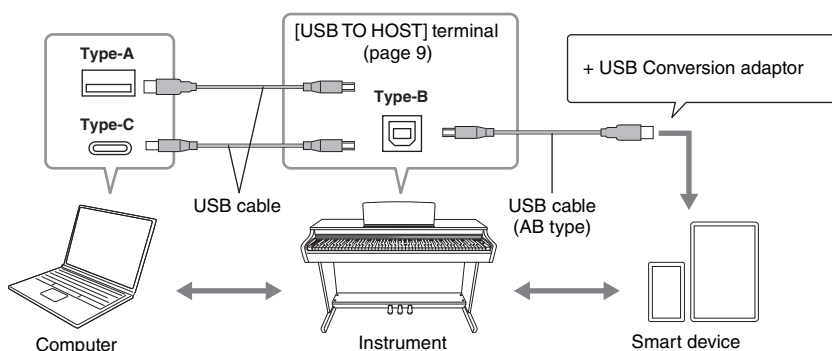

When transmitting or receiving audio signals by using a computer running Windows, if operation is unstable or delays occur, use the "Yamaha Steinberg USB Driver." On the website below, search for "Yamaha Steinberg USB Driver" and install it on the computer. For instructions on installing the driver, refer to the Installation Guide included with the download file.
<https://download.yamaha.com/>

NOTICE

If you are using a DAW (digital audio workstation) application with this instrument, set the Audio Loopback function to off (page 31). Otherwise, a loud sound may occur, depending on the settings of the computer.

NOTE

Depending on the model or OS of the computer and smart device, noise may occur, or this function may not be available.

Precautions when using the [USB TO HOST] terminal

When connecting a smart device or a computer to the [USB TO HOST] terminal, make sure to observe the following points to avoid freezing the smart device, computer or instrument, and corrupting or losing the data.

NOTICE

- Use a USB cable of less than 3 meters. USB 3.0 cables cannot be used.
- Execute the following before turning the power to the instrument on/off or plugging/unplugging the USB cable to/from the [USB TO HOST] terminal.
 - Quit any open app on the smart device/computer.
 - Make sure that data is not being transmitted from the instrument. (Data is transmitted even when the notes on the keyboard are played or a Song is played back.)
- While the smart device/computer is connected to the instrument, you should wait for six seconds or more between these operations: (1) when turning the power of the instrument off then on again, or (2) when alternately connecting/disconnecting the USB cable.

If the smart device, computer or instrument freezes, restart the app or the computer/smart device, or turn the power to the instrument off then on again.

Turning Audio Loop Back On/Off

You can set whether audio sound input from the [USB TO HOST] terminal is returned to the computer/smart device or not along with the performance played on the instrument.

While holding down [DEMO/SONG] and [PIANO/VOICE] simultaneously, press the C6 key to turn this parameter “Off” or the C#6 key to turn it “On.”

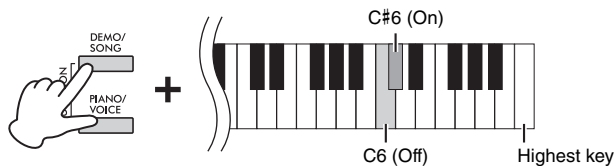

Default setting:

On

Listening to Audio via Bluetooth on this Instrument (Bluetooth Audio)

Before using the Bluetooth function, be sure to read “About Bluetooth” on page 32.

A Bluetooth-equipped audio player such as a smart device or a computer can be connected by using the Bluetooth Audio function. Audio playback on the connected device is output from the built-in speakers of this instrument.

To connect via Bluetooth, the Bluetooth function of this instrument should be turned on. By default, the Bluetooth function is set to on, however you can turn it on/off (page 32).

1. **Hold down the [REC] and [PLAY] buttons simultaneously for three second or longer to pair with a Bluetooth-equipped device (Pairing*).**

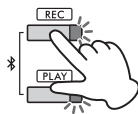

To cancel the pairing, press any button.

2. **On the audio player, set the Bluetooth function to on and select the instrument “YDP-*** Audio” (***) is the model name) from the connection list.**

Make sure to complete this operation while the [REC] and [PLAY] buttons are flashing.

3. **Play back audio data on the Bluetooth-equipped device to confirm that the built-in speakers of the instrument can output the audio sound.**

NOTE

- In order to use the Bluetooth function via wireless communication, the audio player must be equipped for transmitting audio data. For proper operation, the device must be compatible with A2DP (Advanced Audio Distribution Profile).
- Since this instrument cannot transmit audio data to external devices via Bluetooth, Bluetooth headphones or speakers cannot be connected.

* Pairing:

To register this instrument with a Bluetooth-equipped device and establish mutual recognition for wireless communication between the two.

Turning Bluetooth On/Off

To connect the instrument with a Bluetooth-equipped device via Bluetooth Audio or Bluetooth MIDI, you need to turn Bluetooth on. While holding down [DEMO/SONG] and [PIANO/VOICE] simultaneously, press the F1 key to turn this parameter “Off” or the F#1 key to turn it “On.”

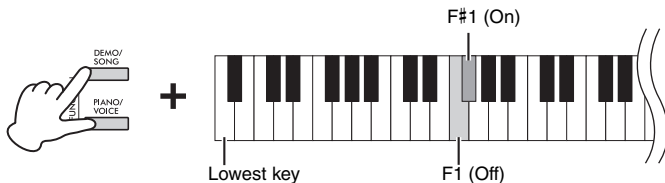

Default setting:
On

About Bluetooth®

Bluetooth is a technology for wireless communication between devices within an area of about 10 meters (33 ft.) employing the 2.4 GHz frequency band.

Handling Bluetooth communications

- The 2.4 GHz band used by Bluetooth compatible devices is a radio band shared by many types of equipment. While Bluetooth compatible devices use a technology minimizing the influence of other components using the same radio band, such influence may reduce the speed or distance of communications and in some cases interrupt communications.
- The speed of signal transfer and the distance at which communication is possible differs according to the distance between the communicating devices, the presence of obstacles, radio wave conditions and the type of equipment.
- Yamaha does not guarantee all wireless connections between this unit and devices compatible with Bluetooth function.

Using the convenient Smart Pianist app

By connecting to a smart device such as a smartphone or tablet and using Smart Pianist, you have access to a variety of exceptionally convenient functions, such as viewing music scores and recording your performances to the device. The intuitive visual interface also helps you confirm the current settings of the instrument.



For details on the app and compatible devices, access the website below and check the “Smart Pianist” page.

<https://www.yamaha.com/2/pianoapps/>

After installing the Smart Pianist app on your smart device, connect this instrument to the device via USB cables or Bluetooth. For instructions on how to connect the device and use the app, refer to “Smart Pianist User Guide” (page 8).

NOTICE

All settings on the instrument are replaced by the settings on Smart Pianist when the instrument is connected with Smart Pianist.

NOTE

While Smart Pianist is connected, you cannot use the control panel on the instrument. Use Smart Pianist to control the instrument. To disconnect Smart Pianist, close Smart Pianist on the smart device or press the [DEMO/SONG] and [PIANO/VOICE] buttons simultaneously on the instrument. You can also disconnect from the Smart Pianist by turning off the power using the [⏻] (Standby/On).

Connecting via Bluetooth

Before using the Bluetooth function, be sure to read “About Bluetooth” on page 32.

To connect the instrument and a smart device via Bluetooth, you need to make Bluetooth MIDI and Bluetooth Audio settings individually. In order to use Smart Pianist, Bluetooth MIDI connection is necessary. For listening to audio data on the smart device from the instrument, Bluetooth Audio connection is required as well.

1. Connect the instrument and the smart device by Bluetooth Audio (page 31).

When the connection is successful, audio data can be transmitted from the smart device to the instrument.

2. By using the Smart Pianist app, connect the instrument and the smart device via Bluetooth MIDI.

For details on connection, refer to “Smart Pianist User Guide” (page 8). Make sure to select “YDP-*** MIDI” (***) is the model name) for pairing. When the connection is successful, MIDI data can be transmitted/received between the instrument and the smart device.

Connecting with a USB cable ([USB TO HOST] terminal)

By using a USB cable, you can connect a smart device to the [USB TO HOST] terminal on the instrument. For instructions on connection, refer to “Smart Pianist User Guide” (page 8). Before using the [USB TO HOST] terminal, refer to “Precautions when using the [USB TO HOST] terminal” on page 30.

Example

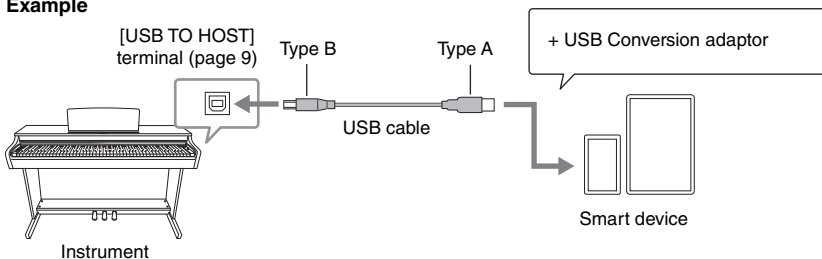

NOTE

When the device is connected by Bluetooth, you cannot record in audio format by using Smart Pianist. To enable audio recording, connect via USB cable (see below).

NOTICE

Use an AB type USB cable of less than 3 meters. The cable must be a communication cable compliant with USB standards, and not a charging-only cable.

Backing up Data and Initializing the Settings

Data Maintained When Power is Turned Off

The following settings and data are maintained even if you turn the power off.

- Metronome Volume
- Metronome Beat (time signature)
- Touch Sensitivity
- Tuning
- Intelligent Acoustic Control Depth
- Intelligent Acoustic Control On/Off
- Volume Limiter On/Off
- Stereophonic Optimizer On/Off
- Operation Confirmation Sounds On/Off
- Auto Power Off Enable/Disable
- Speaker On/Off
- User Song data
- Duo Type Separated/Balanced
- Bluetooth On/Off

Initializing the Settings

With this operation, all data (with the exception of the User Song) will be reset to the factory default settings. To do this, simultaneously hold down the C7 (the highest) key and turn on the power.

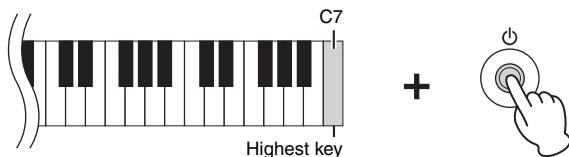

NOTICE
Never turn off the power while the Initialize operation is being executed (that is, while the [REC], [PLAY], [+R] and [-L] lamps are flashing).

NOTE
If this instrument somehow becomes disabled or malfunctions, turn off the power then execute Initialization.

Confirming the firmware version of this instrument

You can confirm the firmware version of your instrument by audible voice in English. While holding down [DEMO/SONG] and [PIANO/VOICE] simultaneously, press the B0 key.

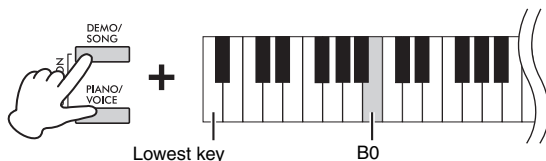

About the latest Firmware Version

Yamaha may from time to time update firmware of the product without notice for improvement. Make sure to check our website for information of the latest release and upgrade the firmware for your instrument.

Troubleshooting

Problem	Possible Cause and Solution
Power suddenly and unexpectedly turns off.	This is normal and the Auto Power Off function may have been activated (page 14). If desired, disable the Auto Power Off function.
The power of the instrument does not turn on.	The plugs are not properly connected. Make sure that the DC plug is securely inserted into the DC IN jack on the instrument, and that the AC plug is securely inserted to the AC outlet (page 13).
A click or pop is heard when the power is turned on or off.	This is normal when electrical current is being applied to the instrument.
Noise is heard from the speakers or headphones.	The noise may be due to interference caused by the use of a mobile phone in close proximity to this instrument. Turn off the mobile phone, or move it further away from this instrument.
	When you use the instrument along with the application on your smart device, we recommend that you set "Airplane Mode" to "ON" on your smart device in order to avoid noise caused by communication.
The overall volume is low, or no sound is heard.	The Master Volume is set too low. Set it to an appropriate level using the [VOLUME] knob (page 10).
	Make sure a pair of headphones or conversion adaptor is not connected to the [PHONES] jack (page 15).
	The Speaker setting is "Off." Set the Speaker to "Normal" or "On" (page 15).
	The Volume Limiter setting is "On." Set the Volume Limiter to "Off" (page 14).
	Make sure that Local Control is On. For details, refer to the "MIDI Reference" (page 8).
Pedals do not function.	The pedal cord may not be securely connected to the [TO PEDAL] jack. Be sure to insert the pedal cord all the way until the metal part of the cord plug disappears from view (page 17).
The pitch and sound quality of the Piano Voice is wrong in a specific key range.	This is no problem. Yamaha develops the Piano Voices so that the original piano sound is reproduced as faithfully as possible. This is why you may hear overtones emphasized in a certain key range, or you may feel that the sound pitch or quality is different from another key range.
Playing the keys produces a rattling noise.	This is no problem. The keyboard mechanism of this product is designed to simulate the actual noises of an acoustic piano. Such noises are produced even if you play an acoustic piano.
The [+R] and [-L] lamps flash when this product is started, when a Song is selected, or when recording is finished.	This is no problem. It is because the [+R] and [-L] lamps may flash when the internal processing of this product is taking a long time. Note that no operations are available while these are flashing.

Problem	Possible Cause and Solution
The Bluetooth-equipped audio player cannot be paired with nor connected to the instrument.	Check that the Bluetooth function of the audio player is activated. To connect the audio player and the instrument via Bluetooth, both devices need to be functional.
	The audio player and the instrument need to be paired to connect with each other via Bluetooth (page 31).
	In case there is a device (microwave oven, wireless LAN device, etc.) that outputs signals in the 2.4 GHz frequency band nearby, move this instrument away from the device that is emitting radio-frequency signals.

* Depending on the country in which you purchased the product, the instrument may not have Bluetooth capability. For information on whether Bluetooth functionality is included or not, refer to page 31.

For more information, check the “Frequently Asked Questions (FAQ)” on the following website:
<https://faq.yamaha.com/s/>

* Available in English, German, French, Spanish and some other languages.

Keyboard Stand Assembly

YDP-166, YDP-146	page 38
YDP-S56, YDP-S36	page 41

Before assembling the instrument, be sure to read the precautions below.

Assembly Precautions

⚠ CAUTION

- Assemble the instrument using at least two people.
- Assemble the instrument on a hard and flat floor with ample space.
- Be sure to use the correct parts in the correct orientation, and assemble the instrument in accordance with the sequence given here.
- Keep small parts (such as screws) out of the reach of infants. Children may accidentally swallow them.
- Be sure to use only the included screws of specified sizes. Use of any other screws can cause damage or malfunction of the product.
- To disassemble the unit, reverse the assembly sequence given here.

Have a Phillips-head (+) screwdriver of the appropriate size ready.

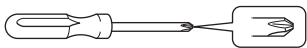

Post-assembly checklist

- There are no unused parts.
 - The instrument is stable even if you shake it.
 - The pedal adjuster is firmly pressed against the floor surface.
 - Both the pedal cord and power cord are plugged securely into the correct jacks.
- If there are any items above you haven't confirmed, review the assembly procedure and correct any errors.

⚠ CAUTION

If the unit creaks or is otherwise unsteady when you play on the keyboard, refer to the assembly diagrams and re-tighten all screws.

Moving/Installing

When moving the instrument, be sure to keep the instrument horizontal and hold with two or more people. Do not subject the instrument to excessive vibration or shock. After re-installation, check the assembly checklist. If you move to another location, you can transport the instrument along with other belongings. The unit can be transported either assembled or disassembled.

We recommend that you place the instrument away from the wall by about 5 cm to optimize and enhance the overall sound even further.

⚠ CAUTION

Always hold the bottom of the main unit. Moving the unit by holding any part other than the bottom may cause damage to the unit or personal injury.

NOTICE

Rotate the adjuster under the pedal until it no longer touches the floor surface before moving the instrument. The adjuster can damage the floor.

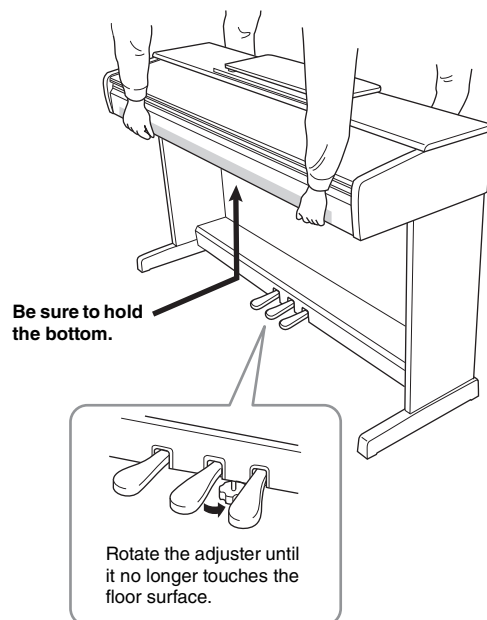







YDP-166, YDP-146 Assembly

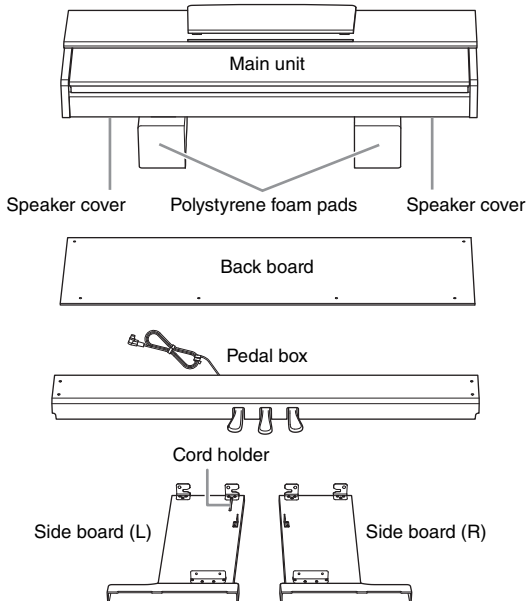

Check if you have all of the items indicated below.

NOTICE

Make sure to place the main unit on the polystyrene foam pads that have been removed from the packages. Position the pads so that they will not contact the speaker covers on the bottom of the main unit.

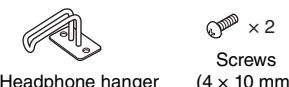

-  × 4
Flat head screws (6 × 20 mm)
-  × 4
Caps
-  × 2
Thin screws (4 × 12 mm)
-  × 4
Tapping screws (4 × 20 mm)
-  × 4
Thick screws (6 × 16 mm)

<p>YDP-166</p>  <p>AC adaptor Power cord</p> <p>— Headphone hanger set —</p>  <p>Headphone hanger Screws (4 × 10 mm)</p>	<p>YDP-146</p>  <p>AC adaptor</p>
--	---

* The adaptor may not be included, or may look different from the illustration above, depending on your particular area.

1. Align the side boards with each end of pedal box, and lightly tighten with flat head screws (6 × 20 mm) for temporary fastening

These screws will be tightened securely later in step 3.

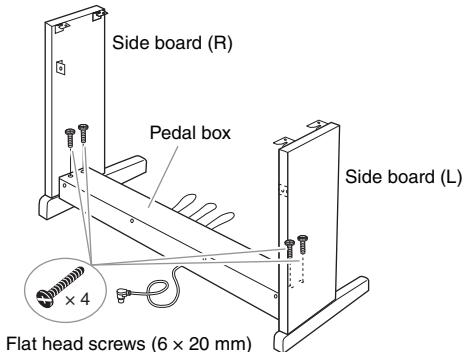

2. Attach the back board.

Depending on the model, the surface color of one side of the back board may be different from the other side. In this case, position the back board so that the side facing the front (pedal side) matches the color of the main unit.

- 2-1 Place the back board on each foot of side boards.
- 2-2 Attach the top of the back board by temporarily fastening the thin screws (4 × 12 mm).
- 2-3 While pushing on the lower part of the side boards from the outside, secure the bottom ends of the back board using tapping screws (4 × 20 mm) in the order from outside to inside (1 → 2).
- 2-4 Securely tighten the screws on the top of the back board that were attached in step 2-2.

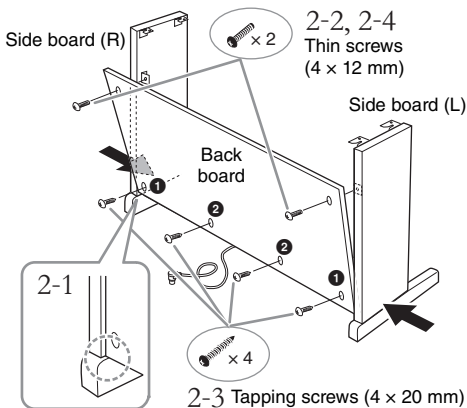

3. Secure the pedal box.

3-1 Securely tighten the screws on the pedal box that were attached in step 1.

3-2 Attach the caps to the screw heads.

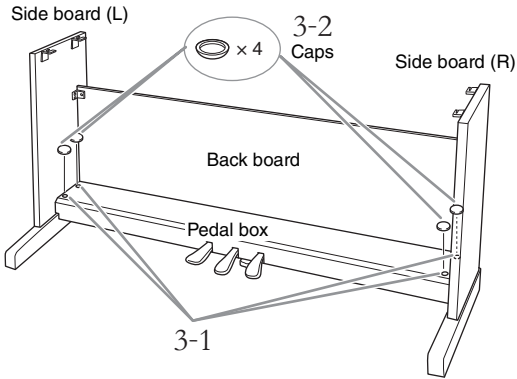

4. Set the main unit in place.

4-1 Be sure to hold the bottom surface at least 10 cm inside from the edge of the main unit so that you do not pinch your hands.

4-2 Place the main unit on the side boards so that the front of the main unit and the side boards are aligned. Slide the main unit forward and insert the metal fittings on the bottom of the main unit into the metal fittings on the side boards.

⚠ CAUTION

- Be careful not to pinch your hands or drop the main unit.
- Do not hold anywhere other than the specified position.

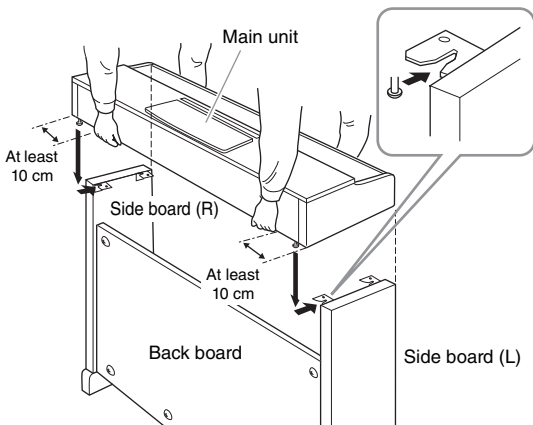

5. Secure the main unit by tightening the thick screws (6 × 16 mm).

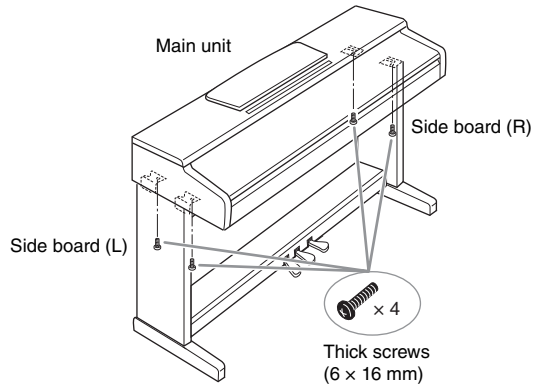

6. Connect the pedal cord plug and the power plug.

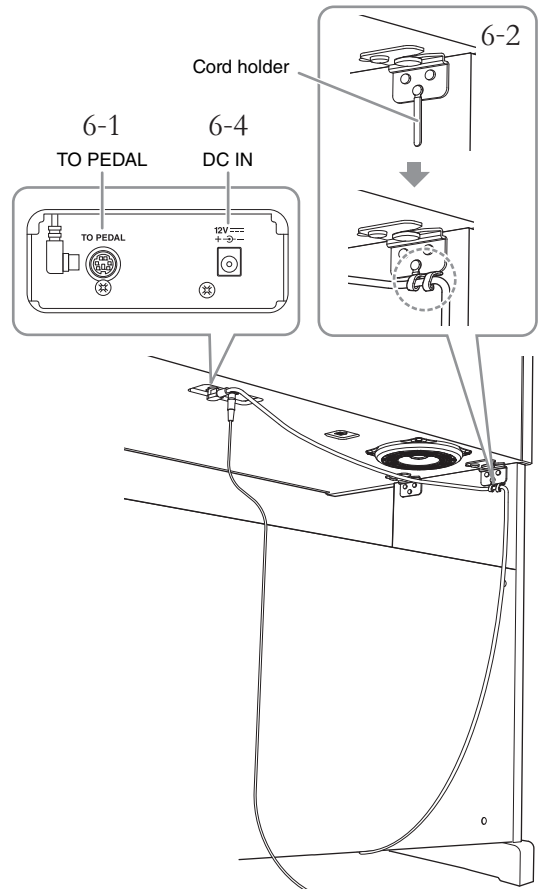

- 6-1 **Insert the pedal cord plug to the [TO PEDAL] jack from the rear.**
Insert the plug until the metal part disappears from view.

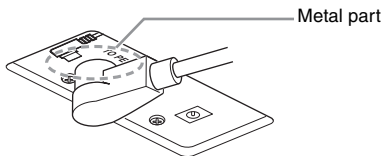

NOTICE
If it is not plugged in firmly, it may cause the pedals to not work.

- 6-2 **Wind the cord holders around pedal cord to hold it.**
The cord holders are attached to the side board (L).

- 6-3 (YDP-166 only) **Connect the power cord to the AC adaptor.**

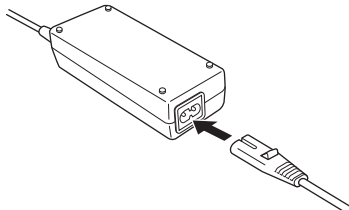

- 6-4 **Insert the DC plug into the DC IN jack.**

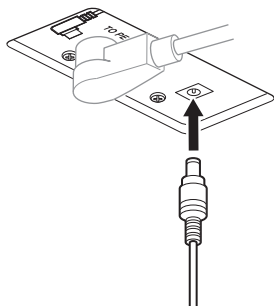

- 7. **Rotate the adjuster until it presses in firm contact with the floor surface.**
Make sure that the pedal box does not rattle or give way when you step on the pedals.

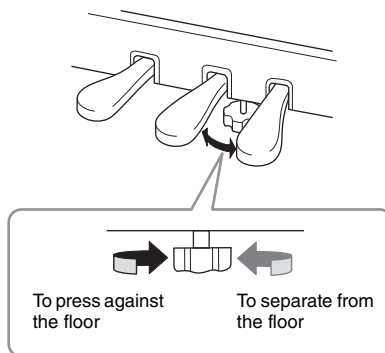

- 8. (YDP-166 only) **Attach the headphone hanger.**

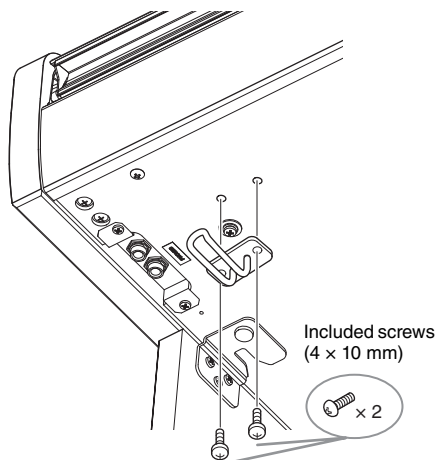

→ Post-assembly checklist (page 37)

YDP-S56, YDP-S36 Assembly

Check if you have all of the items indicated below.

NOTICE

Make sure to place the main unit on the polystyrene foam pads that have been removed from the packages. Position the pads so that they will not contact the connector panel on the bottom of the main unit.

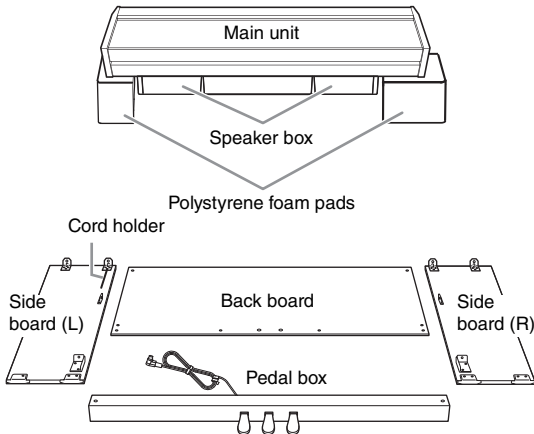

× 2
Flat head screws
(6 × 20 mm)



× 2
Caps



× 2
Thin screws (4 × 12 mm)



× 4
Long screws (6 × 25 mm)



× 2
Tapping screws (4 × 20 mm)



× 4
Thick screws (6 × 16 mm)



Anti-fall bracket (L)



Anti-fall bracket (R)

* The anti-fall brackets are not for earthquake countermeasures.

YDP-S56



AC adaptor



Power cord

YDP-S36



AC adaptor

* The adaptor may not be included, or may look different from the illustration above, depending on your particular area.

1. Align the side boards with each end of pedal box, and lightly tighten with flat head screws (6 × 20 mm) for temporary fastening.

These screws will be tightened securely later in step 3.

Leave the pedal cord out on the back side of the instrument.

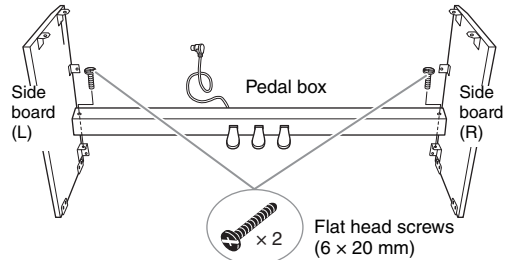

2. Attach the back board.

Depending on the model, the surface color of one side of the back board may be different from the other side. In this case, position the back board so that the side facing the front (pedal side) matches the color of the main unit.

- 2-1 Attach the top of the back board by temporarily fastening the thin screws (4 × 12 mm).
- 2-2 While pushing the lower part of the side board from the outside, fix the lower side of the back board on both sides with long screws (6 × 25 mm). Also, fix the anti-fall brackets together here.
- 2-3 Secure the remaining two places on the lower side with tapping screws (4 × 20 mm).

2-4 Re-tighten the screws on the upper side of the back board that were temporarily fastened in step 2-1.

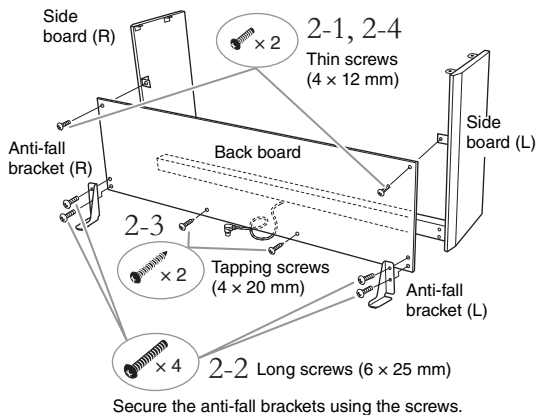

CAUTION
 Be sure to attach the anti-fall brackets. Failure to do so might result in damage to the instrument or even injury.

3. Secure the pedal box.

3-1 Securely tighten the screws on the pedal box that were attached in step 1.

3-2 Attach the caps to the screw heads.

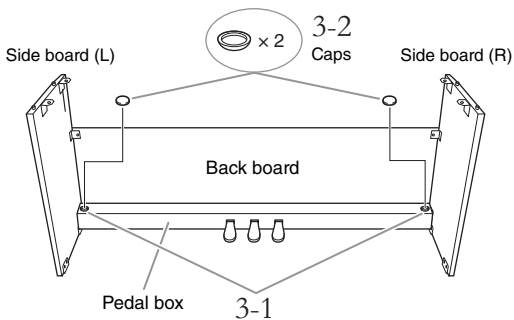

4. Set the main unit in place.

Be sure to hold the bottom surface 10 cm or more inside from the edge of the main unit so that you do not pinch your hands.

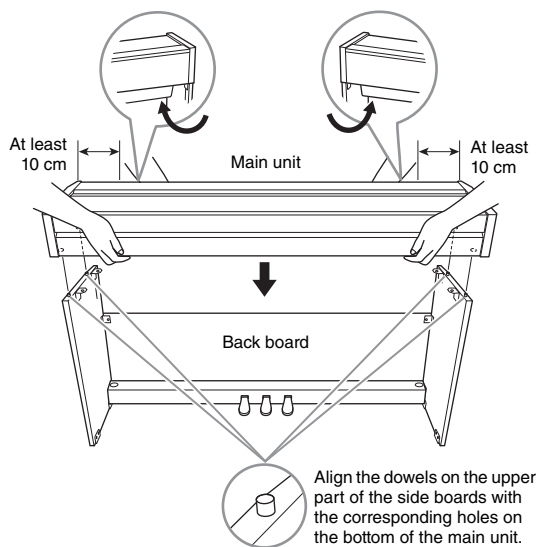

CAUTION

- Be careful not to pinch your hands or drop the main unit.
- Do not hold anywhere other than the specified position.

5. Secure the main unit by tightening the thick screws (6 x 16 mm).

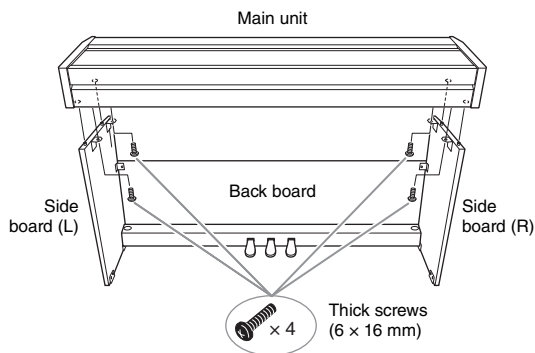

6. Connect the pedal cord plug and the power plug.

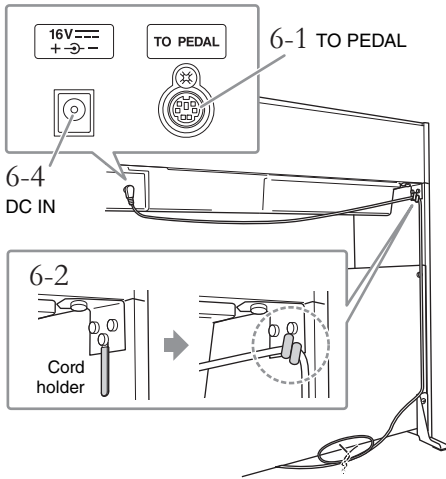

6-1 Insert the pedal cord plug to the [TO PEDAL] jack from the rear.

Insert the plug until the metal part disappears from view.

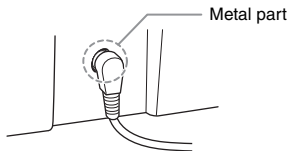

NOTICE

If it is not plugged in firmly, it may cause the pedals to not work.

6-2 Wind the cord holder around pedal cord to hold it.

The cord holder is attached to the side board (L).

6-3 (YDP-S56 only) Connect the power cord to the AC adaptor.

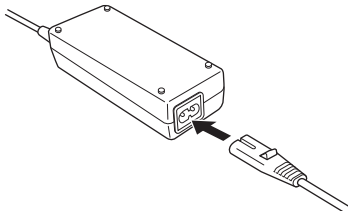

6-4 Insert the DC plug into the DC IN jack.

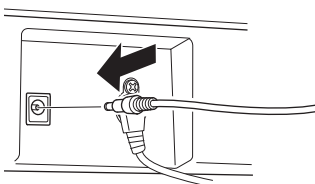

7. Rotate the adjuster until it presses in firm contact with the floor surface.

Make sure that the pedal box does not rattle or give way when you step on the pedals.

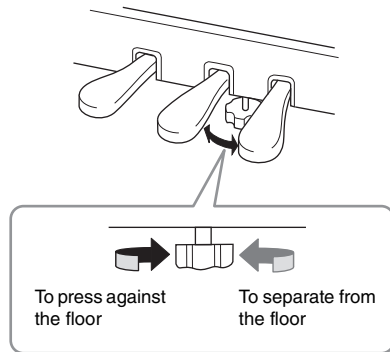

→ Post-assembly checklist (page 37)

Specifications

		YDP-166	YDP-146	YDP-S56	YDP-S36	
Product Name		Digital Piano				
Size/Weight	Width	1,357 mm [53-7/16"]		1,353 mm [53-1/4"]		
	Height	With music rest closed	849 mm [33-7/16"]	815 mm [32-1/16"]	792 mm [31-3/16"]	
		With music rest raised	1,003 mm [39-1/2"]	969 mm [38-1/8"]		
	Height with Key cover open		—		976 mm [38-7/16"]	968 mm [38-1/8"]
	Depth		422 mm [16-5/8"]		309 mm [12-3/16"] (Key cover open: 317 mm [12-1/2"]) *With anti-fall brackets attached, the depth is 382 mm [15-1/16"].	296 mm [11-5/8"] (Key cover open: 309 mm [12-3/16"]) *With anti-fall brackets attached, the depth is 366 mm [14-7/16"].
Weight		42 kg (92 lbs., 10 oz.)	38 kg (83 lbs., 12 oz.)	40 kg (88 lbs., 3 oz.)	37 kg (81 lbs., 9 oz.)	
Control Interface	Keyboard	Number of Keys	88			
		Type	GrandTouch-E Keyboard: synthetic ebony and ivory key tops, escapement	GHS (Graded Hammer Standard) keyboard with matte black keytops	GrandTouch-E Keyboard: synthetic ebony and ivory key tops, escapement	GHS (Graded Hammer Standard) keyboard with matte black keytops
		Touch	Hard/Medium/Soft/Fixed			
	Pedal	Number of Pedals	3: Damper (with Half-pedal function), Sostenuto, Soft			
	Panel	Language	English			
Cabinet	Key Cover Style		Sliding		Folding	
	Music Rest		Yes (with music braces)	Yes		
Voices	Tone Generator	Piano Sound	Yamaha CFX			
		VRM (Virtual Resonance Modeling)	Yes (VRM Lite)			
	Polyphony (max.)		192			
Preset	Number of Voices	10				
Effects	Types	Reverb	4 types			
		Intelligent Acoustic Control (IAC)	Yes			
		Stereophonic Optimizer	Yes			
	Functions	Dual	Yes			
Duo		Yes				
Songs	Preset	Number of Preset Songs	10 Voice Demo Songs, 50 Classics, 303 Lesson Songs			
	MIDI Recording	Number of Songs	1			
		Number of Tracks	2			
		Data Capacity	Approx. 150 KB/Song (approx. 11,000 notes)	Approx. 100 KB/Song (approx. 11,000 notes)	Approx. 150 KB/Song (approx. 11,000 notes)	Approx. 100 KB/Song (approx. 11,000 notes)
	Compatible Data Format	Playback	SMF (Format 0, Format 1)			
Recording		SMF (Format 0)				
Functions	Overall Controls	Metronome	Yes			
		Tempo Range	5 – 280			
		Transpose	–6 – 0 – +6			
		Tuning	414.8 – 440.0 – 466.8 Hz (approx. 0.2 Hz increments)			
		USB Audio Interface	44.1 kHz, 24-bit, stereo			
	Bluetooth (May not have this functionality depending on the country in which you purchased the product.)	Audio	Supported profile: A2DP, Compatible codec: SBC			
		MIDI	Comply with Bluetooth Low Energy MIDI Specification			
		Bluetooth version	5.0			
		Wireless output	Bluetooth Class 2			
		Maximum communication distance	Approx. 10 m			
		Radio Frequency	2,401 – 2,481 MHz			
		Maximum output power (EIRP)	4 dBm			
		Type of modulation	GFSK			
Connectivity	Headphones		Standard stereo phone jack (x 2)			
	USB TO HOST		Type B			
	DC IN		16 V	12 V	16 V	12 V

		YDP-166	YDP-146	YDP-S56	YDP-S36
Amplifiers and Speakers	Amplifiers	20 W × 2	8 W × 2	20 W × 2	8 W × 2
	Speakers	12 cm with diffuser × 2			
Power Supply	AC Adaptor	PA-300C	PA-150 or an equivalent recommended by Yamaha	PA-300C	PA-150 or an equivalent recommended by Yamaha
		Output	DC 16 V, 2.4 A	DC 12 V, 1.5 A	DC 16 V, 2.4 A
	Polarity	+ ⊖ -			
	Power Consumption	13 W (When using PA-300C AC adaptor)	9 W (When using PA-150 AC adaptor)	13 W (When using PA-300C AC adaptor)	9 W (When using PA-150 AC adaptor)
	Standby Power Consumption	0.3 W			
	Auto Power Off	Yes			
Included Accessories	<ul style="list-style-type: none"> • Owner's Manual • "50 Classical Music Masterpieces" music book • Online Member Product Registration • AC adaptor: PA-300C • Power cord • Bench* <p>* May not be included depending on your area. Check with your Yamaha dealer.</p>	<ul style="list-style-type: none"> • Owner's Manual • "50 Classical Music Masterpieces" music book • Online Member Product Registration • AC adaptor: PA-150 or an equivalent recommended by Yamaha • Bench* <p>* May not be included depending on your area. Check with your Yamaha dealer.</p>	<ul style="list-style-type: none"> • Owner's Manual • "50 Classical Music Masterpieces" music book • Online Member Product Registration • AC adaptor: PA-300C • Power cord 	<ul style="list-style-type: none"> • Owner's Manual • "50 Classical Music Masterpieces" music book • Online Member Product Registration • AC adaptor: PA-150 or an equivalent recommended by Yamaha 	
Separately Sold Accessories (May not be available depending on your area.)	<ul style="list-style-type: none"> • Headphones: HPH-150, HPH-100, HPH-50 • Pedal unit: FC35 • AC adaptor: PA-300C 	<ul style="list-style-type: none"> • Headphones: HPH-150, HPH-100, HPH-50 • Pedal unit: FC35 • AC adaptor: PA-150 or an equivalent recommended by Yamaha 	<ul style="list-style-type: none"> • Headphones: HPH-150, HPH-100, HPH-50 • Pedal unit: FC35 • AC adaptor: PA-300C 	<ul style="list-style-type: none"> • Headphones: HPH-150, HPH-100, HPH-50 • Pedal unit: FC35 • AC adaptor: PA-150 or an equivalent recommended by Yamaha 	

* The contents of this manual apply to the latest specifications as of the publishing date. To obtain the latest manual, access the Yamaha website then download the manual file. Since specifications, equipment or separately sold accessories may not be the same in every locale, please check with your Yamaha dealer.

Information for users on collection and disposal of old equipment:



This symbol on the products, packaging, and/or accompanying documents means that used electrical and electronic products should not be mixed with general household waste.

For proper treatment, recovery and recycling of old products, please take them to applicable collection points, in accordance with your national legislation.

By disposing of these products correctly, you will help to save valuable resources and prevent any potential negative effects on human health and the environment which could otherwise arise from inappropriate waste handling.

For more information about collection and recycling of old products, please contact your local municipality, your waste disposal service or the point of sale where you purchased the items.

For business users in the European Union:

If you wish to discard electrical and electronic equipment, please contact your dealer or supplier for further information.

Information on Disposal in other Countries outside the European Union:

symbol is only valid in the European Union. If you wish to discard these items, please contact your local authorities or dealer and ask for the correct method of disposal.

(58-M02 WEEE en 01)

Index

Numerics

50 Classical Music Masterpieces 26, 47

A

AC adaptor13
Accessories8
Assembly37
Audio Loop Back31
Auto Power Off14

B

Backing up Data34
Beat19
Bluetooth 31, 32, 33

C

Computer30

D

Damper Pedal17
Delete29
Demo Song List21
Demo Songs21
Dual mode24
Duo25

F

Firmware version34

H

Half-pedal17
Headphones15
Hz (Hertz)23

I

Initializing34
Intelligent Acoustic Control (IAC)16

K

Key Cover 11, 12

L

Left-hand Part27
Lesson Songs47

M

Manuals8
Metronome19
MIDI Reference8
Music Rest 11, 12

O

Octave24
Operation Confirmation Sounds 14

P

Panel Controls and Terminals 9
Pedals17
Pitch23
Playback26
Power13

Q

Quick Operation Guide52
Quick Play27

R

Recording28
Reverb22
Reverb Depth22
Reverb Type22
Right-hand Part27

S

Smart Device30
Soft Pedal17
Song26
Song List47
Sostenuto Pedal17
Speaker15
Stereophonic Optimizer15

T

Tempo19
Time signature19
Touch Sensitivity18
Transpose23
Tuning23

U

USB Audio Interface30
USB TO HOST10, 30, 33
User Song28

V

Voice20
Voice List20
Volume10, 19
Volume Limiter14
VRM Lite18

Song List

50 Classical Music Masterpieces

No.	Song Title	Composer
Arrangements		
1	Canon D dur	J. Pachelbel
2	Air On the G String	J. S. Bach
3	Jesus, Joy of Man's Desiring	J. S. Bach
4	Twinkle, Twinkle, Little Star	Traditional
5	Piano Sonata op.31-2 "Tempest" 3rd mov.	L. v. Beethoven
6	Ode to Joy	L. v. Beethoven
7	Wiegenlied op.98-2	F. P. Schubert
8	Grande Valse Brillante	F. F. Chopin
9	Polonaise op.53 "Héroïque"	F. F. Chopin
10	La Campanella	F. Liszt
11	Salut d'amour op.12	E. Elgar
12	From the New World	A. Dvořák
13	Sicilienne	G. U. Fauré
14	Clair de lune	C. A. Debussy
15	Jupiter (The Planets)	G. Holst
Duets		
16	Menuett (Eine kleine Nachtmusik K.525)	W. A. Mozart
17	Menuett G dur	L. v. Beethoven
18	Marcia alla Turca	L. v. Beethoven
19	Piano Concerto No.1 op.11 2nd mov.	F. F. Chopin
20	The Nutcracker Medley	P. I. Tchaikovsky
Original Compositions		
21	Prelude (Wohltemperierte Klavier I No.1)	J. S. Bach
22	Menuett G dur BWV Anh.114	J. S. Bach
23	Piano Sonata No.15 K.545 1st mov.	W. A. Mozart
24	Turkish March	W. A. Mozart
25	Piano Sonata op.13 "Pathétique" 2nd mov.	L. v. Beethoven
26	Für Elise	L. v. Beethoven
27	Piano Sonata op.27-2 "Mondschein" 1st mov.	L. v. Beethoven
28	Impromptu op.90-2	F. P. Schubert
29	Frühlingslied op.62-6	J. L. F. Mendelssohn
30	Fantaisie-Impromptu	F. F. Chopin
31	Etude op.10-3 "Chanson de l'adieu"	F. F. Chopin
32	Etude op.10-12 "Revolutionary"	F. F. Chopin
33	Valse op.64-1 "Petit chien"	F. F. Chopin
34	Nocturne op.9-2	F. F. Chopin
35	Nocturne KK4a-16/BI 49 [Posth.]	F. F. Chopin
36	Träumerei	R. Schumann
37	Barcarolle	P. I. Tchaikovsky
38	La prière d'une Vierge	T. Badarzewska
39	Liebesträume No.3	F. Liszt
40	Blumenlied	G. Lange
41	Humoresque	A. Dvořák
42	Arietta	E. H. Grieg
43	Tango (España)	I. Albéniz
44	The Entertainer	S. Joplin
45	Maple Leaf Rag	S. Joplin
46	La Fille aux Cheveux de Lin	C. A. Debussy
47	Arabesque No.1	C. A. Debussy
48	Cakewalk	C. A. Debussy
49	Je te veux	E. Satie
50	Gymnopédies No.1	E. Satie

Lesson Songs

No.	Album Title	Title No. /Song Title	Composer
1-50	Vorschule im Klavierspiel op.101	1-50	F. Beyer
1-50		51-100	
1-6		101-106	
1-25	25 Etudes faciles et progressives op.100	1 La candeur	J. F. Burgmüller
		2 Arabesque	
		3 Pastorale	
		4 Petite réunion	
		5 Innocence	
		6 Progrès	
		7 Courant limpide	
		8 La gracieuse	
		9 La chasse	
		10 Tendre fleur	
		11 La bergersonnette	
		12 Adieu	
		13 Consolation	
		14 La styrienne	
		15 Ballade	
		16 Douce plainte	
		17 Babillarde	
		18 Inquiétude	
		19 Ave Maria	
		20 Tarentelle	
		21 Harmonie des anges	
		22 Barcarolle	
		23 Retour	
		24 L'hirondelle	
		25 La chevaleresque	
1-50	100 Übungsstücke op.139	1-50	C. Czerny
1-50		51-100	
1-30	30 Etudes de mécanisme op.849	1-30	C. Czerny
1-20 21-42	The Virtuoso Pianist	1-20 1-Variation. 1-22	C-L. Hanon

Duet Songs

- Nos.16–20 of "50 Classical Music Masterpieces"
- Nos. 1–11 of the Vorschule im Klavierspiel op.101 of "Lesson Songs" as well as 32–34, 41–44, 63–64, and 86–87

The right-hand part ([+R]) is for the right hand of the first player, and the left-hand part ([-L]) is for the left hand of the first player. The second player's parts cannot be turned off.

MEMO

Important Notice: Guarantee Information for customers in European Economic Area (EEA) and Switzerland

<p>Important Notice: Guarantee Information for customers in EEA* and Switzerland</p> <p>For detailed guarantee information about this Yamaha product, and Pan-EEA* and Switzerland warranty service, please either visit the website address below (Printable file is available at our website) or contact the Yamaha representative office for your country. * EEA: European Economic Area</p>	English
<p>Wichtiger Hinweis: Garantie-Information für Kunden in der EWR* und der Schweiz</p> <p>Für nähere Garantie-Information über dieses Produkt von Yamaha, sowie über den Pan-EWR*- und Schweizer Garantieservice, besuchen Sie bitte entweder die folgend angegebene Internetadresse (eine druckfähige Version befindet sich auch auf unserer Webseite), oder wenden Sie sich an den für Ihr Land zuständigen Yamaha-Vertrieb. *EWR: Europäischer Wirtschaftsraum</p>	Deutsch
<p>Remarque importante: informations de garantie pour les clients de l'EEE et la Suisse</p> <p>Pour des informations plus détaillées sur la garantie de ce produit Yamaha et sur le service de garantie applicable dans l'ensemble de l'EEE ainsi qu'en Suisse, consultez notre site Web à l'adresse ci-dessous (Le fichier imprimable est disponible sur notre site Web) ou contactez directement Yamaha dans votre pays de résidence. * EEE : Espace Economique Européen</p>	Français
<p>Belangrijke mededeling: Garantie-informatie voor klanten in de EER* en Zwitserland</p> <p>Voor gedetailleerde garantie-informatie over dit Yamaha-product en de garantieservice in heel de EER* en Zwitserland, gaat u naar de onderstaande website (u vindt een afdrukbaar bestand op onze website) of neemt u contact op met de vertegenwoordiging van Yamaha in uw land. * EER: Europese Economische Ruimte</p>	Nederlands
<p>Aviso importante: información sobre la garantía para los clientes del EEE* y Suiza</p> <p>Para una información detallada sobre este producto Yamaha y sobre el soporte de garantía en la zona EEE* y Suiza, visite la dirección web que se incluye más abajo (la versión del archivo para imprimir esta disponible en nuestro sitio web) o póngase en contacto con el representante de Yamaha en su país. * EEE: Espacio Económico Europeo</p>	Español
<p>Avviso importante: informazioni sulla garanzia per i clienti residenti nell'EEA* e in Svizzera</p> <p>Per informazioni dettagliate sulla garanzia relativa a questo prodotto Yamaha e l'assistenza in garanzia nei paesi EEA* e in Svizzera, potete consultare il sito Web all'indirizzo riportato di seguito (è disponibile il file in formato stampabile) oppure contattare l'ufficio di rappresentanza locale della Yamaha. * EEA: Area Economica Europea</p>	Italiano
<p>Aviso importante: informações sobre as garantias para clientes da AEE* e da Suíça</p> <p>Para obter uma informação pormenorizada sobre este produto da Yamaha e o serviço de garantia na AEE* e na Suíça, visite o site a seguir (o arquivo para impressão está disponível no nosso site) ou entre em contato com o escritório de representação da Yamaha no seu país. * AEE: Área Económica Européia</p>	Português
<p>Σημαντική σημείωση: Πληροφορίες εγγύησης για τους πελάτες στον ΕΟΧ* και Ελλάδα</p> <p>Για λεπτομερείς πληροφορίες εγγύησης σχετικά με το παρόν προϊόν της Yamaha και την κάλυψη εγγύησης σε όλες τις χώρες του ΕΟΧ και την Ελλάδα, επισκεφτείτε την παρακάτω ιστοσελίδα (Εκτυπώσιμη μορφή είναι διαθέσιμη στην ιστοσελίδα μας) ή απευθυνθείτε στην αντιπροσωπεία της Yamaha στη χώρα σας. * ΕΟΧ: Ευρωπαϊκός Οικονομικός Χώρος</p>	Ελληνικά
<p>Viktigt: Garantiinformation för kunder i EES-området* och Schweiz</p> <p>För detaljerad information om denna Yamahaprodukt samt garantiservice i hela EES-området* och Schweiz kan du antingen besöka nedanstående webbadress (en utskriftsvänlig fil finns på webbplatsen) eller kontakta Yamahas officiella representant i ditt land. * EES: Europeiska Ekonomiska Samarbetsområdet</p>	Svenska
<p>Viktig merknad: Garantiinformasjon for kunder i EØS* og Sveits</p> <p>Detaljert garantiinformasjon om dette Yamaha-produktet og garantiservice for hele EØS-området* og Sveits kan fås enten ved å besøke nettstedene nedenfor (utskriftsversjon finnes på våre nettsider) eller kontakte Yamahas kontoret i landet der du bor. *EØS: Det europeiske økonomiske samarbeidsområdet</p>	Norsk
<p>Vigtig oplysning: Garantioplysninger til kunder i EØO* og Schweiz</p> <p>De kan finde detaljerede garantioplysninger om dette Yamaha-produkt og den fælles garantiserviceordning for EØO* (og Schweiz) ved at besøge det websted, der er angivet nedenfor (der findes en fil, som kan udskrives, på vores websted), eller ved at kontakte Yamahas nationale repræsentationskontor i det land, hvor De bor. * EØO: Det Europæiske Økonomiske Område</p>	Dansk
<p>Tärkeä ilmoitus: Takuutiedot Euroopan talusalueen (ETA)* ja Sveitsin asiakkaille</p> <p>Tämän Yamaha-tuotteen sekä ETA-alueen ja Sveitsin takuuta koskevat yksityiskohtaiset tiedot saatte alla olevasta nettiosoitteesta. (Tulostettava tiedosto saatavissa sivustollamme.) Voitte myös ottaa yhteyttä paikalliseen Yamaha-edustajaan. *ETA: Euroopan talusalue</p>	Suomi
<p>Ważne: Warunki gwarancyjne obowiązujące w EOG* i Szwajcarii</p> <p>Aby dowiedzieć się więcej na temat warunków gwarancyjnych tego produktu firmy Yamaha i serwisu gwarancyjnego w całym EOG* i Szwajcarii, należy odwiedzić wskazaną poniżej stronę internetową (Plik gotowy do wydruku znajduje się na naszej stronie internetowej) lub skontaktować się z przedstawicielstwem firmy Yamaha w swoim kraju. * EOG — Europejski Obszar Gospodarczy</p>	Polski
<p>Důležité oznámení: Záruční informace pro zákazníky v EHS* a ve Švýcarsku</p> <p>Podrobné záruční informace o tomto produktu Yamaha a záručním servisu v celém EHS* a ve Švýcarsku naleznete na níže uvedené webové adrese (soubor k tisku je dostupný na našich webových stránkách) nebo se můžete obrátit na zastoupení firmy Yamaha ve své zemi. * EHS: Evropský hospodářský prostor</p>	Česky
<p>Fontos figyelemzetés: Garancia-információk az EGT* területén és Svájcban élő vásárlók számára</p> <p>A jelen Yamaha termékre vonatkozó részletes garancia-információk, valamint az EGT*-re és Svájcra kiterjedő garanciális szolgáltatás tekintetében keresse fel webhelyünket az alábbi címen (a webhelyen nyomtatható fájl is talál), vagy pedig lépjen kapcsolatba az országában működő Yamaha képviselői irodával. * EGT: Európai Gazdasági Térség</p>	Magyar
<p>Oluline märkus: Garantiteave Euroopa Majanduspiirkonna (EMP)* ja Šveitsi klientidele</p> <p>Täpsema teabe saamiseks selle Yamaha toote garantii ning kogu Euroopa Majanduspiirkonna ja Šveitsi garantiiteeninduse kohta, külastage palun veebisaiti alljärgneval aadressil (meie saidil on saadaval printitav fail) või pöörduge Teie regiooni Yamaha esinduse poole. * EMP: Euroopa Majanduspiirkond</p>	Eesti keel
<p>Svarīgs paziņojums: garantijas informācija klientiem EEZ* un Šveicē</p> <p>Lai saņemtu detalizētu garantijas informāciju par šo Yamaha produktu, kā arī garantijas apkalpošanu EEZ* un Šveicē, lūdzam apmeklējiet zemāk norādīto tīmekļa vietnes adresi (tīmekļa vietnē ir pieejams drukājams fails) vai sazinieties ar jūsu valsti apkalpojošo Yamaha pārstāvniecību. * EEZ: Eiropas Ekonomikas zona</p>	Latviešu
<p>Démosio: informacija dėl garantijos pirkėjams EEE* ir Šveicarijoje</p> <p>Jei reikia išsamios informacijos apie šį „Yamaha“ produktą ir jo techninę priežiūrą visoje EEE* ir Šveicarijoje, apsilankykite mūsų svetainėje toliau nurodytu adresu (svetainėje yra spausdintinas failas) arba kreipkitės į „Yamaha“ atstovybę savo šaliai. *EEE – Europos ekonominė erdvė</p>	Lietuvių kalba
<p>Dôležité upozornenie: Informácie o záruke pre zákazníkov v EHP* a Švajčiarsku</p> <p>Podrobné informácie o záruke týkajúce sa tohto produktu od spoločnosti Yamaha a garančnom servise v EHP* a Švajčiarsku nájdete na webovej stránke uvedenej nižšie (na našej webovej stránke je k dispozícii súbor na tlač) alebo sa obráťte na zástupcu spoločnosti Yamaha vo svojej krajine. * EHP: Európsky hospodársky priestor</p>	Slovenčina
<p>Pomembno obvestilo: Informacije o garanciji za kupce v EGP* in Švici</p> <p>Za podrobnejše informacije o tem Yamahinem izdelku ter garancijskem servisu v celotnem EGP in Švici, obiščite spletno mesto, ki je navedeno spodaj (natisljiva datoteka je na voljo na našem spletnem mestu), ali se obrnite na Yamahinega predstavnika v svoji državi. * EGP: Evropski gospodarski prostor</p>	Slovenščina
<p>Важно съобщение: Информация за гаранцията за клиенти в ЕИП* и Швейцария</p> <p>За подробна информация за гаранцията за този продукт на Yamaha и гаранционното обслужване в паневропейската зона на ЕИП* и Швейцария или посетете посочения по-долу уеб сайт (на нашия уеб сайт има файл за печат), или се свържете с представителния офис на Yamaha във вашата страна. * ЕИП: Европейско икономическо пространство</p>	Български език
<p>Notificare importantă: Informații despre garanție pentru clienții din SEE* și Elveția</p> <p>Pentru informații detaliate privind acest produs Yamaha și serviciul de garanție Pan-SEE* și Elveția, vizitați site-ul la adresa de mai jos (fișierul imprimabil este disponibil pe site-ul nostru) sau contactați biroul reprezentanței Yamaha din țara dumneavoastră. * SEE: Spațiul Economic European</p>	Limba română
<p>Važna obavijest: Informacije o jamstvu za države EGP-a i Švicarske</p> <p>Za detaljne informacije o jamstvu za ovaj Yamahin proizvod te jamstvenom servisu za cijeli EGP i Švicarsku, molimo Vas da posjetite web-stranicu navedenu u nastavku ili kontaktirate ovlaštenog Yamahinog dobavljača u svojoj zemlji. * EGP: Europski gospodarski prostor</p>	Hrvatski

<https://europe.yamaha.com/warranty/>

Yamaha Worldwide Representative Offices

English

For details on the product(s), contact your nearest Yamaha representative or the authorized distributor, found by accessing the 2D barcode below.

Deutsch

Wenden Sie sich für nähere Informationen zu Produkten an eine Yamaha-Vertretung oder einen autorisierten Händler in Ihrer Nähe. Diese finden Sie mithilfe des unten abgebildeten 2D-Strichodes.

Français

Pour obtenir des informations sur le ou les produits, contactez votre représentant ou revendeur agréé Yamaha le plus proche. Vous le trouverez à l'aide du code-barres 2D ci-dessous.

Español

Para ver información detallada sobre el producto, contacte con su representante o distribuidor autorizado Yamaha más cercano. Lo encontrará escaneando el siguiente código de barras 2D.

Português

Para mais informações sobre o(s) produto(s), fale com seu representante da Yamaha mais próximo ou com o distribuidor autorizado acessando o código de barras 2D abaixo.

Русский

Чтобы узнать подробнее о продукте (продуктах), свяжитесь с ближайшим представителем или авторизованным дистрибьютором Yamaha, воспользовавшись двухмерным штрихкодом ниже.

Bahasa Indonesia

Untuk detail produk, hubungi perwakilan Yamaha terdekat atau distributor resmi Anda dengan mengakses barcode 2D di bawah ini.

简体中文

如需有关产品的详细信息,请联系距您最近的 Yamaha 代表或授权经销商,可通过访问下方的二维码找到这些代表或经销商的信息。

繁體中文

如需產品的詳細資訊,請聯絡與您距離最近的 Yamaha 銷售代表或授權經銷商,您可以掃描下方的二維條碼查看相關聯絡資料。

한국어

제품에 대한 자세한 정보는 아래 2D 바코드에 액세스하여 가까운 Yamaha 담당 판매점 또는 공식 대리점에 문의하십시오.



https://manual.yamaha.com/mi/address_list/



ARIUS YDP-166, YDP-146, YDP-S56, YDP-S36

Quick Operation Guide

While holding down the applicable button, press one of the highlighted keys or buttons shown below to select a Song or set a parameter.



© 2026 Yamaha Corporation
Published 03/2026
MWMA-A1

VHT6120

1 Song playback To select a Song, follow step **1** (Book Select), and then step **2** (Song No. Select).



Quick Play

A#-1	Off	On
C0 D0	50 Classics	Beyer 1-50
E0 F0	Beyer 51-100	Beyer 101-106
G0 A0	Burgmüller 1-25	Czerny 100, 1-50
B0 C1	Czerny 100, 1-50	Czerny 100, 51-100
D1 E1	Czerny 30, 1-30	Hanon
F1 G1	CFX Grand	Mellow Grand
A1 B1	Pop Grand	Stage E.Piano
C2 D2	DX E.Piano	Harpisichord
E2 F2	Harpisichord	Vibraphone
G2 A2	Pipe Organ	Jazz Organ
B2 C3	Strings	1
D3 E3	2	3
F3 G3	4	5
A3 B3	6	7
C4 D4	8	9
E4 F4	10	11
G4 A4	12	13
B4 C5	14	15
D5 E5	16	17
F5 G5	18	19
A5 B5	20	21
C6 D6	22	23
E6 F6	24	25
G6 A6	26	27
B6 C7	28	29
	30	31
	32	33
	34	35
	36	37
	38	39
	40	41
	42	43
	44	45
	46	47
	48	49
	50	

1 Book Select

Demo Songs

2 Song No. Select

1 Book	2 Song No.
50 Classical Music Masterpieces (50 Classics)	1-50 ●
Beyer 1-50	1-50
Beyer 51-100	1-50
Beyer 101-106	1-6
Burgmüller 1-25	1-25
Czerny 100, 1-50	1-50
Czerny 100, 51-100	1-50
Czerny 30, 1-30	1-30
Hanon 1-20	1-20
Hanon Variation 1-22	21-42

1 50 Classical Music Masterpieces (Number/Song)	2
1 Canon D dur	11 Saulu d'amour op.12
2 Air On the G String	12 From the New World
3 Jesus, Joy of Man's Desiring	13 Sicilienne
4 Trinkle, Trinkle, Little Star	14 Clair de lune
5 Piano Sonata op.31-2 "Tempest" 3rd mov.	15 Jupiter (The Planets)
6 Ode to Joy	16 Menuett (Eine kleine Nachtmusik K.525)
7 Wogenlied op.98-2	17 Menuett G dur
8 Grande Valse Brillante	18 Marche alla Turca
9 Polonaise op.53 "Héroïque"	19 Piano Concerto No.1 op.11 2nd mov.
10 La Campanella	20 The Nutcracker Medley
	21 Prelude (Wohltemperierte Klavier I No.1)
	22 Menuett G dur BWV Anh.1/4
	23 Piano Sonata No.15 K.545 1st mov.
	24 Turkish March
	25 Piano Sonata op.13 "Pathétique" 2nd mov.
	26 Für Elise
	27 Piano Sonate op.27-2 "Mondschein" 1st mov.
	28 Imprompu op.90-2
	29 Frühlingstied op.82-6
	30 Farnaise-Imprompu
	31 Etude op.10-3 "Chanson de l'adieu" 41 Humoresque
	32 Etude op.10-12 "Revolutionary" 42 Arieta
	33 Valse op.64-1 "Petit chien" 43 Tango (España)
	34 Nocturne op.9-2 44 The Entertainer
	35 Nocturne K(Ka-16/BI 49 [Posth.] 45 Maple Leaf Rag
	36 Träumerei 46 La Fille aux Cheveux de Lin
	37 Barcarolle 47 Arabesque No.1
	38 La prière d'une Vierge 48 Cakewalk
	39 Liebestraume No.3 49 Je te veux
	40 Blumenlied 50 Gymnopédies No.1

2 Voice settings

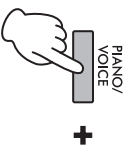

A#-1	CFX Grand	Mellow Grand
C0 D0	Pop Grand	Stage E.Piano
E0 F0	DX E.Piano	Harpisichord
G0 A0	Harpisichord	Vibraphone
B0 C1	Pipe Organ	Jazz Organ
D1 E1	Strings	1
F1 G1	2	3
A1 B1	4	5
C2 D2	6	7
E2 F2	8	9
G2 A2	10	11
B2 C3	12	13
D3 E3	14	15
F3 G3	16	17
A3 B3	18	19
C4 D4	20	21
E4 F4	22	23
G4 A4	24	25
B4 C5	26	27
D5 E5	28	29
F5 G5	30	31
A5 B5	32	33
C6 D6	34	35
E6 F6	36	37
G6 A6	38	39
B6 C7	40	41

Voices	Reverb Types	Reverb Depth	VRII Lite	Stereophonic Optimizer	Duo Type	Volume Balance (Dual/Duo mode)	Octave Shift (Dual/Duo mode)	Touch Sensitivity
CFX Grand	Recital Hall	1 step down	Off	Off	Balanced	1 step down	-1 (Voice 2)	Soft
Mellow Grand	Concert Hall	Default setting	On	On	Separated	Default setting	0 (Voice 2)	Medium
Pop Grand	Chamber	1 step up	Off	Off		1 step up	+1 (Voice 2)	Hard
Stage E.Piano	Club		On	On			-1 (Voice 1)	Fixed
Harpisichord	Off		Off	Off			+1 (Voice 1)	
Vibraphone			On	On				
Jazz Organ			Off	Off				