

Clarett 8PreX

User Guide

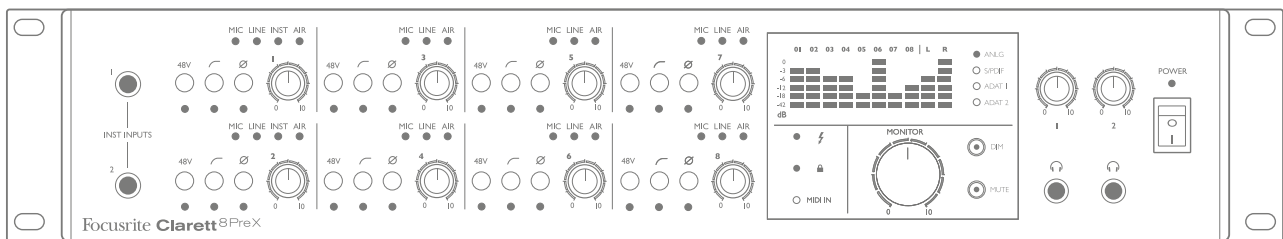

Focusrite®
www.focusrite.com

TABLE OF CONTENTS

OVERVIEW	3
Introduction	3
System Requirements	3
Features	4
Box Contents	4
Getting Started	5
Software Installation	5
Hardware Features	6
Front Panel	6
Rear Panel	8
Connecting your Clarett 8PreX	10
Computer audio setup	10
Audio Setup in your DAW	10
Connecting Clarett 8PreX to loudspeakers	11
Examples of Usage	12
1. Recording a band	12
2. Project Studio	13
3. Using the optical connections to provide additional inputs	14
4. Using the optical connections to provide additional outputs	15
FOCUSRITE CONTROL - OVERVIEW	16
CLARETT 8PRE TECHNICAL SPECIFICATIONS	17
Performance Specifications	17
Physical and Electrical Characteristics	18
TROUBLESHOOTING	19
COPYRIGHT AND LEGAL NOTICES	19

OVERVIEW

WARNING: Excessive sound pressure levels from earphones and headphones can cause hearing loss.

WARNING: This equipment must only be connected to Thunderbolt™ ports.

Introduction

Thank you for purchasing this Clarett 8PreX, one of the family of Focusrite professional Thunderbolt™ audio interfaces incorporating newly-designed, high quality Clarett analogue pre-amplifiers with the unique AIR function. In conjunction with the Focusrite Control application, you now have a highly versatile and professional solution for routing high quality audio to and from your computer recording system with extremely low latency.

You can also use the Clarett 8PreX as a “stand-alone” interface to any other type of recording device, once you have configured it using Focusrite Control software.

This User Guide provides a detailed explanation of the hardware to help you achieve a thorough understanding of the product’s operational features. We recommend that you take the time to read through the Guide, whether you’re new to computer recording or a more experienced user, so that you are fully aware of all the possibilities that the Clarett 8PreX has to offer.

IMPORTANT: As well as this User Guide, you will need the Focusrite Control Software Guide which can be downloaded from <http://uk.focusrite.com/downloads>.

This contains full details of Focusrite Control, the software application that has been designed specifically for use with the Focusrite Clarett range of interfaces.

If either of the Guides do not provide the information you need, be sure to consult <http://www.focusrite.com/answerbase>, which contains a comprehensive collection of answers to common technical support queries.

System Requirements

IMPORTANT – Please visit the following link for up-to-date information on computer and operating system compatibility for all Clarett products: www.focusrite.com/clarett/compatibility

Features

The Clarett 8PreX hardware interface provides the means for connecting microphones, musical instruments, line level audio signals and digital audio signals to a computer through the computer's Thunderbolt™ port. The signals at the physical inputs can be routed to your audio recording software / digital audio workstation (referred to throughout this user guide as the "DAW"); similarly, the outputs from the DAW can be configured to appear at the unit's physical outputs.

Audio sources – mics, instruments, etc., can be recorded into your DAW and then played back from there through amplifiers and speakers, powered monitors, headphones, a mixer or any other analogue or digital audio equipment that you wish to use. Although all inputs and outputs on the Clarett 8PreX are, by default, routed directly to and from your DAW for recording and playback, you can configure the routing any way you like within the Focusrite Control application in order to meet your precise needs. Please see the Focusrite Control user guide for more info on routing.

The Clarett 8PreX simultaneously provides 26 inputs and 28 outputs. In addition to providing a high quality interface for analogue signals, the Clarett 8PreX also handles multichannel digital audio in ADAT optical format – sixteen channels at 44.1/48 kHz sample rate, eight at 88.2/96 kHz or four at 176.4/192 kHz. S/PDIF I/O is also included.

The Clarett 8PreX can be easily synchronised with other items of digital audio equipment in your studio, either as a slave to an external word clock signal, or by acting as the master clock source itself. It also has standard DIN connectors for sending and receiving MIDI data.

An important feature of all models in the Clarett range is the new design of analogue preamplifier. In addition to their class-leading dynamic range and ability to provide all the gain you're ever likely to need, the circuitry now includes an exciting new AIR function. Individually selectable on each channel, AIR subtly modifies the pre-amp's frequency response to model the impedance and resonance characteristics of Focusrite's classic transformer-based ISA mic preamps. When recording with good quality microphones, you will notice an enhanced clarity and definition in the important mid frequency range, just where it is most needed for vocals and many acoustic instruments.

The accompanying software application, Focusrite Control, is designed to require a minimal amount of user interaction, letting you easily configure the Clarett 8PreX with signal routings appropriate for the most common recording tasks. For more complex situations, it provides extensive routing and monitoring options, as well as the ability to control global hardware settings such as sample rate and synchronisation.

All inputs on the Clarett 8PreX are routed directly to your DAW software for recording, but Focusrite Control also allows you to route these signals internally within the device to the outputs so that you can monitor the audio signals with ultra-low latency - before they arrive at your DAW, should you need to do so.

Box Contents

Along with your Clarett 8PreX you should have:

- AC mains cable with IEC connector
- Getting Started Guide, with codes for accessing the following on-line resources:
 - Drivers as required
 - 1 GB of Loopmasters sounds and samples
 - Focusrite Control
 - Focusrite Red 2/Red 3 Plug-in Suite

GETTING STARTED

IMPORTANT: Please ensure that you install the Clarett 8PreX drivers before connecting the interface to your computer.

Software Installation

All software required by the Clarett 8PreX, including several powerful and useful extras, is available for download from the Focusrite website (www.focusrite.com/register). The Important Information provided with your Clarett 8PreX contains validation codes which you will need to enter at the above web address. This procedure ensures that you will have the most up-to-date software versions.

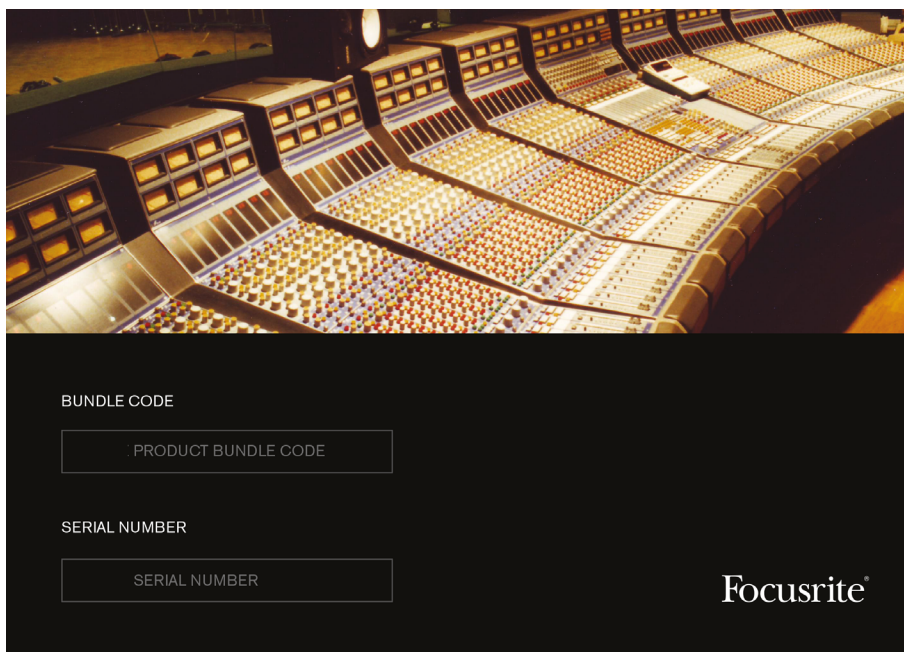

1. Using your usual browser, go to www.focusrite.com/register/
2. Follow the on-screen instructions, entering the “Bundle Code” into the form where prompted. Your Bundle Code can be found on the back of the Getting Started Guide packed with the unit.
3. Enter the unit’s serial number, which can also be found on the back of the Getting Started Guide.
4. You will then be able to access the “My Products” page, where the software products to which your registration entitles you are available for download, complete with activation codes where applicable.
5. Download and install Focusrite Control, which contains the necessary drivers for this interface. Follow all on-screen instructions.
6. When the installation is complete, you will be prompted to restart your computer.
7. After restart, connect the Clarett 8PreX to your computer with a Thunderbolt cable.
8. If you are having trouble getting started please watch our video guide here - www.focusrite.com/get-started

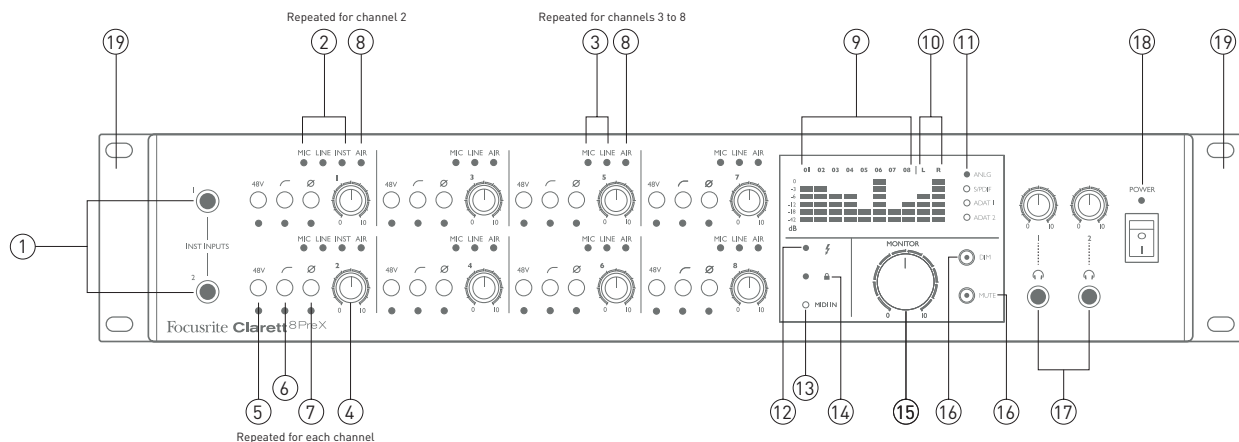

Hardware Features

Front Panel



The front panel includes all the input gain controls and monitoring controls as well as two input sockets for instrument jacks and two headphones sockets.

1. **INST INPUTS** – 2 x high impedance inputs on ¼" TS jack sockets for Channels 1 and 2: connect a musical instrument (e.g., guitar) here.
2. **MIC, LINE & INST** – two sets of three red LEDs indicating the input currently selected for Channels 1 and 2. Mic/Line/Inst selection is made from Focusrite Control.
3. **MIC & LINE** – six pairs of red LEDs indicating the input currently selected for Channels 3 to 8. Mic/Line selection is made from Focusrite Control.
4. Input gain controls **1 to 8** – eight rotary controls: adjust the input gain for the signals in Channels 1 to 8 respectively.
5. **48V** – one switch per channel: enables 48 V phantom power at the corresponding rear panel XLR mic input. Each switch has an associated red LED indicating that phantom power is selected.
6. **Hi-pass filters** – one switch per channel: use to remove unwanted low-frequencies. Filter is -3 dB at 80 Hz with a slope of 12 dB/octave. Each switch has an associated red LED indicating that the filter is active.
7. **Phase reverse** – one switch per channel. Each switch has an associated red LED indicating that the phase is reversed.
8. **AIR** – eight yellow LEDs – one per channel; illuminate when the AIR function is selected from Focusrite Control. AIR modifies the frequency response of the input stage to model the classic, transformer-based Focusrite ISA mic preamps.
9. Input signal level meters: eight LED bargraphs, one per channel. Segments indicate -42, -18 & -12 dBFS (green), -6 & -3 dBFS (yellow) and 0 dBFS (red). Input signals are metered post the input gain controls, so you can see the levels being sent to the DAW.
10. Output signal level meters: two LED bargraphs indicating the signal level at Outputs 1 and 2. Indications as input meters. Output signals are metered pre the monitor level control, so the volume you have set is independent of the meter indications.

11. **ANALOG, S/PDIF, ADAT 1 & ADAT 2** – input meter source LEDs. Indicates the current signal source for the input meters. Meter source selection is made from Focusrite Control.
12.  (Thunderbolt active) – a green LED which illuminates when the unit has established a connection with the computer to which it is connected.
13. **MIDI** – a green LED which illuminates when MIDI data is being received at the rear panel **MIDI IN** port.
14.  – a green LED which confirms clock synchronisation, either to the Clarett 8PreX's internal clock or to an external digital input.
15. **MONITOR** – main monitor output level control – this control will normally control the level at the main monitor outputs on the rear panel, but can be configured in Focusrite Control to adjust the level of any of the unit's ten analogue outputs.
16. **DIM** and **MUTE** – two switches controlling the Clarett 8PreX's monitor outputs; DIM reduces the output levels by 18 dB, while **MUTE** turns the outputs off. By default, these switches affect the main monitor outputs 1 and 2, but they will also affect any analogue outputs that have been selected for front panel monitor control using Focusrite Control. The switches are internally illuminated (DIM: yellow, MUTE: red) indicating that the function is selected.
17. Headphones **1** and **2** – connect one or two pairs of stereo headphones at the two ¼" TRS jack sockets below the controls. The headphone outputs always carry the signals that are currently routed to analogue outputs 7/8 and 9/10 in Focusrite Control.
18. **POWER** – AC power switch and LED.
19. Rack ears for mounting the Clarett 8PreX in a standard 19" equipment rack.

Rear Panel

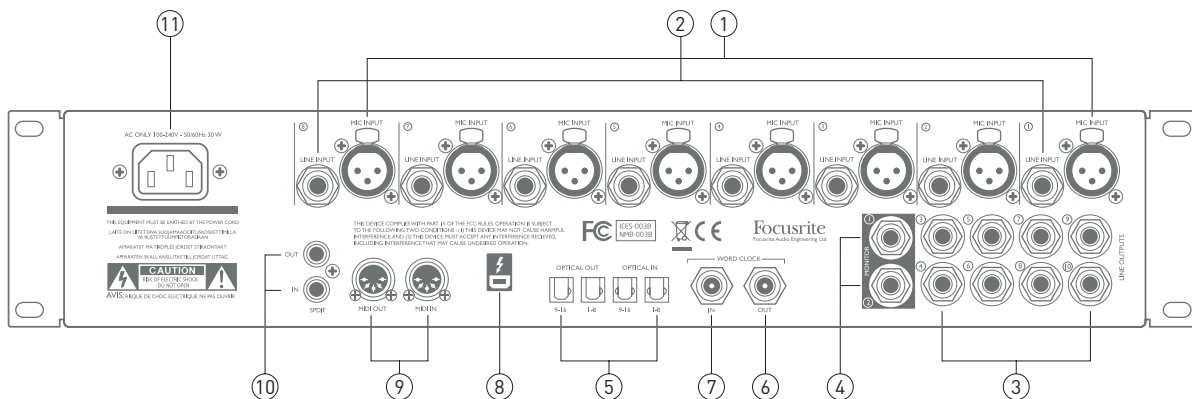

The remainder of the Clarett 8PreX's inputs and outputs are on the rear panel.

1. **MIC INPUTS 1 to 8** – eight balanced mic inputs on 3-pin XLR input sockets - connect microphones via standard XLR mic cables.
2. **LINE INPUTS 1 to 8** – eight balanced line inputs on ¼" jack sockets. Connect line level signals here; either ¼" TRS (balanced) or TS (unbalanced) jack plugs can be used for line level signals.
3. **LINE OUTPUTS 3 to 10** – eight balanced analogue line outputs on ¼" jack sockets; use TRS jacks for a balanced connection or TS jacks for unbalanced. The signals routed to these outputs are defined in Focusrite Control, and can typically be used for driving alternative speakers (i.e., midfield, nearfield, etc.), the additional speakers in a multichannel monitoring system, or to send audio to outboard FX processors.
4. **MONITOR 1 and 2** – two balanced analogue line outputs on ¼" jack sockets; use TRS jacks for a balanced connection or TS jacks for unbalanced. These are also Line Outputs 1 and 2 of the system, and will generally be used for driving the main L and R speakers of your monitoring system. However, the routing of signals to outputs may be customised in Focusrite Control.
5. **OPTICAL IN and OUT** – four TOSLINK connectors (two inputs and two outputs), each carrying eight channels (1 to 8 and 9 to 16) of digital audio in ADAT format at 44.1/48 kHz sample rate, four channels at 88.2/96 kHz or two channels at 176.4/192 kHz. These are simply additional inputs and outputs (respectively) to/from the Clarett 8PreX. The **OPTICAL IN 1-8** connector may alternatively be configured to receive a two-channel S/PDIF signal from an external source equipped with an optical S/PDIF output; similarly, the **OPTICAL OUT 1-8** connector may be set to carry the signal routed to S/PDIF OUT in optical format. These options are selected from Focusrite Control.
6. **WORD CLOCK OUT** – a BNC connector carrying the Clarett 8PreX's word clock; this may be used to synchronise other digital audio equipment forming part of the recording system. The source of sample clock synchronisation used by the Clarett 8PreX is selected in Focusrite Control.
7. **WORD CLOCK IN** – a BNC connector for the connection of an external word clock signal. Use this input if you have a master reference clock which provides synchronisation for all the digital audio devices in your studio.
8. **⚡** – Thunderbolt™ connector; connect the Clarett 8PreX to your computer with a suitable Thunderbolt™ cable.

9. **MIDI IN** and **MIDI OUT** – standard 5-pin DIN sockets for connection of external MIDI equipment, allowing MIDI data to/from your computer to be received and distributed to additional MIDI devices.
10. **SPDIF IN** and **OUT** – two phono (RCA) sockets carrying two-channel digital audio signals in or out of the Clarett 8PreX in S/PDIF format. Like all the other inputs and outputs, the routing of S/PDIF signals may be customised in Focusrite Control.
11. AC mains – standard IEC receptacle. The Clarett 8PreX is fitted with a “Universal” power supply, and will run from any AC mains voltage from 100 to 240 V, at 50 or 60 Hz.

Connecting your Clarett 8PreX

IMPORTANT: Before you connect the Clarett 8PreX to your computer, please complete the software installation according to the instructions on page 5. This will ensure that the hardware uses the correct drivers, and will prevent unexpected behaviour.

The Clarett 8PreX should be connected to AC mains with the supplied AC power cable. Plug the IEC connector into the rear panel IEC receptacle and turn the unit on with the front panel power switch.

The Clarett 8PreX has a Thunderbolt™ port (on the rear panel). Once the software installation is complete, simply connect the Clarett 8PreX to your computer using a Thunderbolt™ cable.

Computer audio setup

Your OS should automatically select the Clarett 8PreX as the default audio device. You can check that this selection has been made correctly, if you wish. Details of how to do this on various operating systems can be found at www.focusrite.com/get-started/clarett8PreX.

Audio Setup in your DAW

After installing the drivers and connecting the hardware, you can start using the Clarett 8PreX with the DAW of your choice.

Please note - your DAW may not automatically select the Clarett 8PreX as its default I/O device. In this case, you must manually select the driver on your DAW's **Audio Setup*** page, and select the **Focusrite Thunderbolt** driver. Please refer to your DAW's documentation (or Help files) if you are unsure where to select the Core Audio driver

* Typical name – page names may vary with DAW

Connecting Clarett 8PreX to loudspeakers

The 1/4" jack **MONITOR** outputs on the rear panel (Line Outputs 1 and 2) will normally be used to drive monitoring speakers. Self-powered monitors (also known as active monitors) incorporate internal amplifiers, and may be connected directly. Passive loudspeakers will require a separate stereo amplifier; in this case, the rear panel outputs should be connected to the amplifier's inputs.

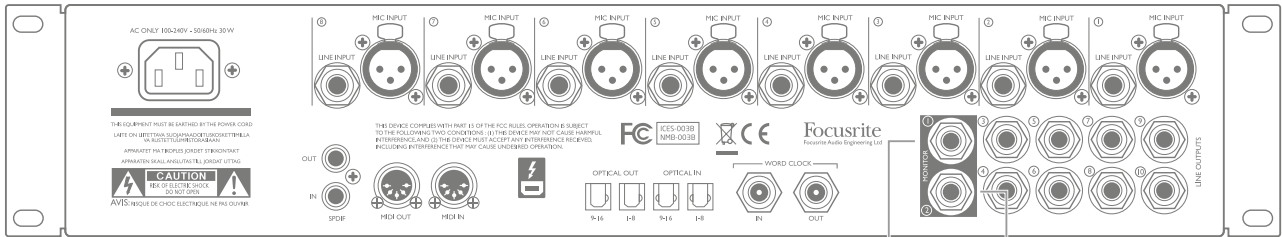

Connecting active speakers

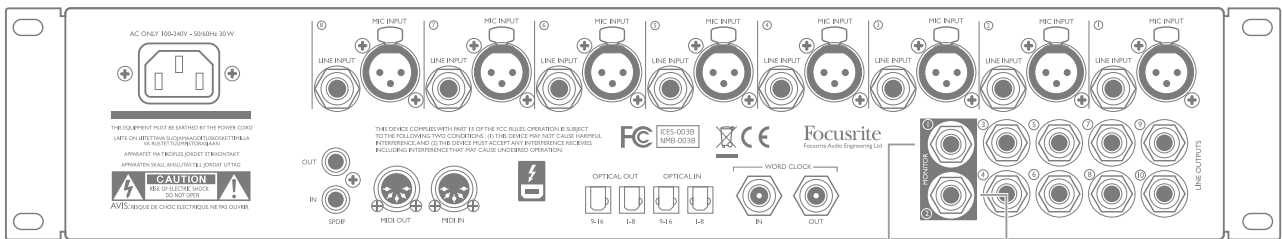
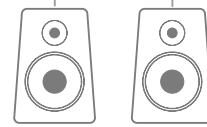

Connecting passive speakers

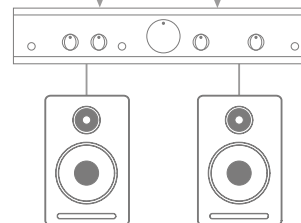

All the line output connectors are 3-pole (TRS) 1/4" jack sockets, and are electronically balanced. Typical consumer (hi-fi) amplifiers and small powered monitors will have unbalanced inputs, either on phono (RCA) sockets, or via a 3.5 mm 3-pole jack plug intended for direct connection to a computer. In either case, use a suitable connecting cable with jack plugs at one end.

Professional power amplifiers will generally have balanced inputs.

When mixing, you can connect several pairs of additional speakers (mid-field, near-field, etc.) to pairs of outputs and use Focusrite Control to route your mix to the different outputs as desired, to check your mix on the different types of speaker.

Examples of Usage

The Clarett 8PreX is an excellent choice for numerous recording and monitoring applications. Some typical configurations are shown below.

1. Recording a band

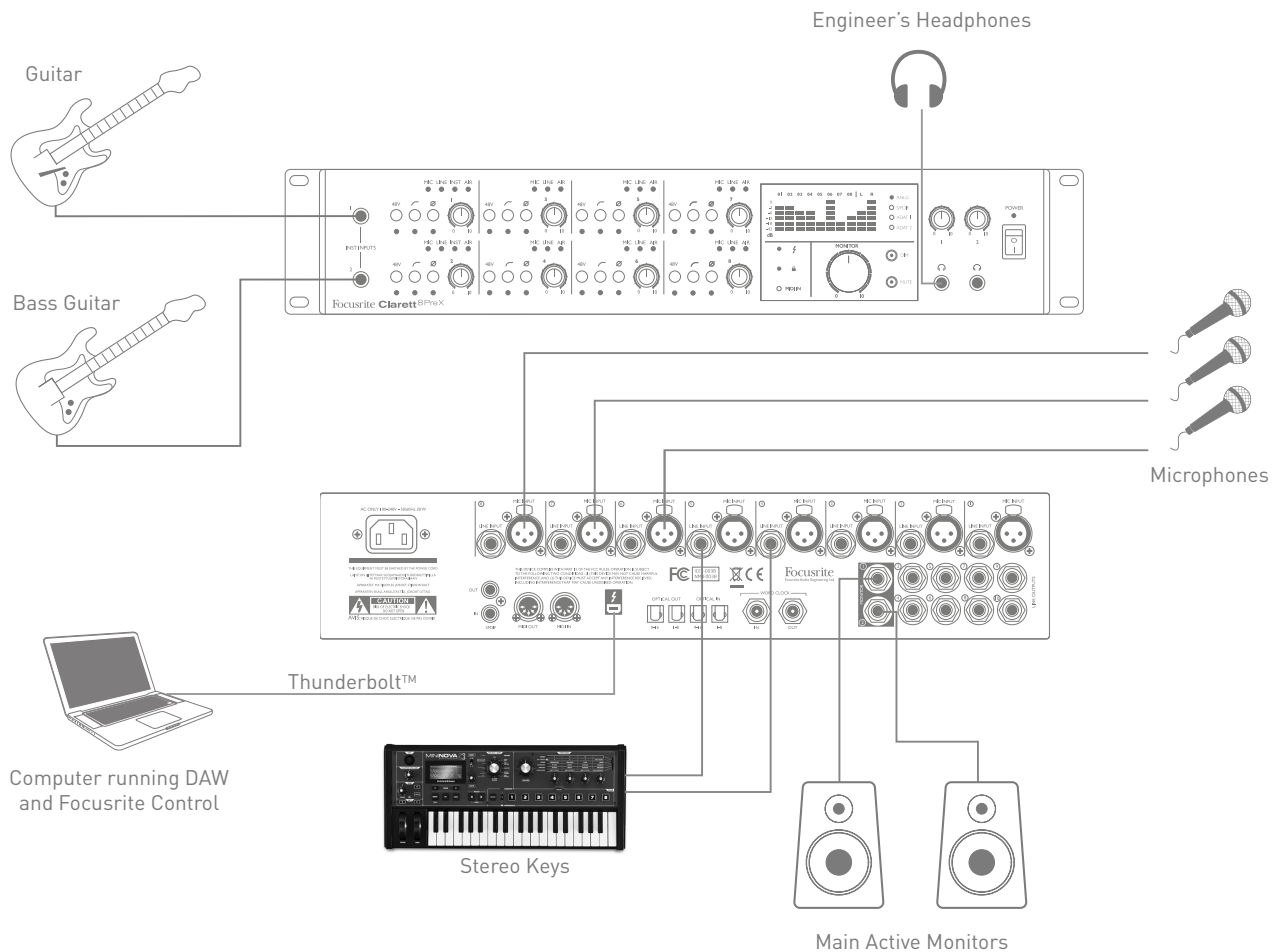

This setup illustrates a typical configuration for multitrack recording with DAW software on your computer.

A selection of sources – microphones, guitars and a keyboard – are shown connected to the Clarett 8PreX's inputs. Note that the guitars are connected to Channels 1 and 2 as they can be configured to accept instruments directly. Ensure that INST mode is selected for these from Focusrite Control, and the INST LEDs are illuminated. Similarly, the stereo keyboard is connected to the line inputs of Channels 4 and 5; select these to LINE from the software.

The connection to the computer running DAW software is via a Thunderbolt™ cable. This will carry all the input and output signals between the DAW and the Clarett 8PreX. Once the audio setup is correctly configured in the DAW, each input source will be automatically routed to its own DAW track for recording.

2. Project Studio

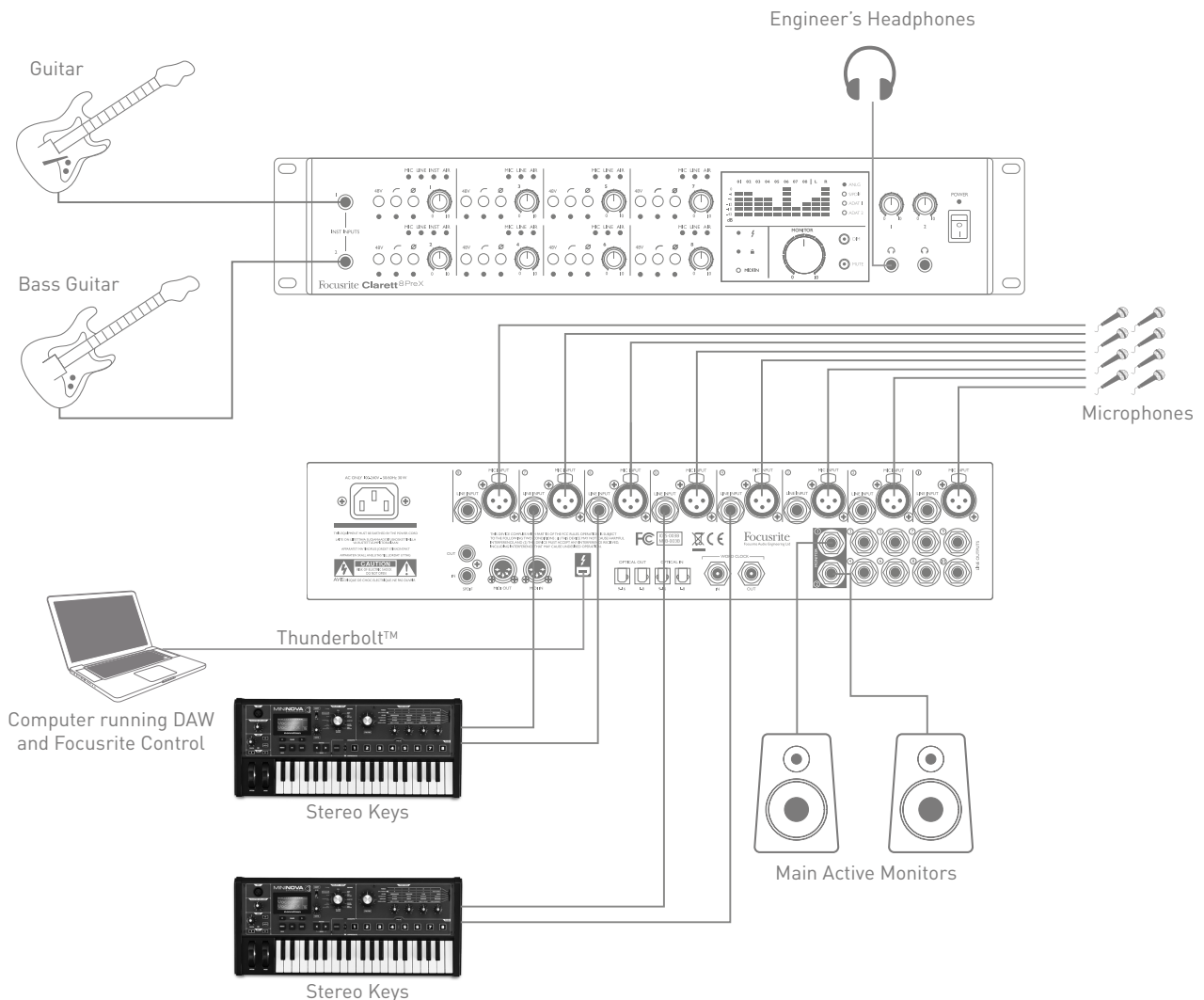

One of the Clarett 8PreX's advantages is the large number of physical inputs it provides. In a project studio, these can be (more or less) permanently committed to specific sound sources, thus minimising the amount of re-patching required when switching from one instrument to another, as you build up the various tracks making up a song.

In the example below, we assume that guitar and bass guitar will remain connected to Channels 1 and 2 via their INST inputs, while various electronic instruments can be connected to the LINE inputs of all channels. The MIC inputs of all channels would typically be connected to mic input sockets at different locations in the recording space.

If more instruments need to be connected permanently in this way, a patchbay can be introduced into the setup; alternatively, the number of inputs can be expanded with an OctoPre unit (see Example 3).

3. Using the optical connections to provide additional inputs

In addition to the eight analogue inputs, the Clarett 8PreX has two ADAT input ports (**OPTICAL IN**) which can each provide an additional 8 audio inputs at 44.1/48 kHz sample rate, four at 88.2/96 kHz or two at 176.4/192 kHz. Using one or two 8-channel microphone preamplifiers equipped with ADAT outputs – such as a pair of Focusrite OctoPre MkIIs – provides a simple and excellent method of expanding the Clarett 8PreX's input capability.

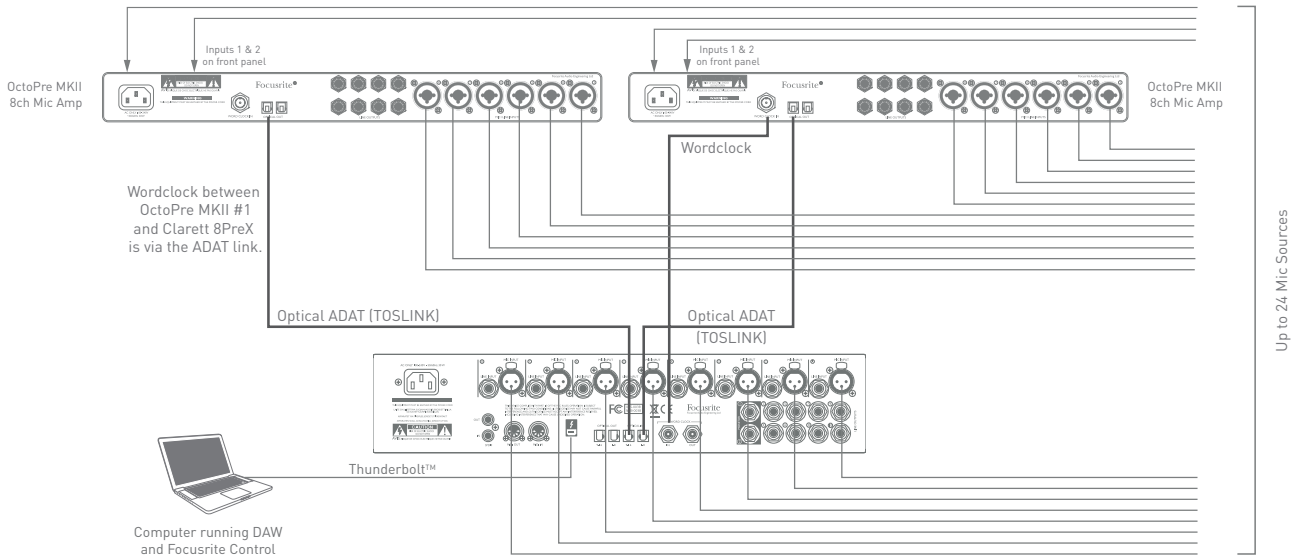

In the example, the **OPTICAL OUT** ports of the OctoPre MkIIs are connected to the Clarett 8PreX's **OPTICAL IN** ports with two TOSLINK optical cables. Although mic inputs are shown in the diagram, this would allow any combination of up to 24 mic or line inputs, of which some could be INST level signals.

Stable word clock synchronisation may be achieved by setting one OctoPre MkII as the sync master and the Clarett 8PreX's sync source as ADAT. The second OctoPre MkII can then be synchronised by connecting its **WORD CLOCK IN** to the **WORD CLOCK OUT** of the Clarett 8PreX with a BNC cable.

NOTE: when interconnecting two digital devices by any method, always ensure that both are set to use the same sample rate.

The additional inputs realised by use of the optical ports may be routed using Focusrite Control in exactly the same manner as the other inputs. The additional inputs can form part of any musician's headphone mix, as required.

4. Using the optical connections to provide additional outputs

The Clarett 8PreX's two ADAT output ports (**OPTICAL OUT**) may be used to feed separate D-A converters to provide additional analogue outputs. The Focusrite OctoPre MkII DYNAMIC is a suitable 8-channel unit for this purpose. As with the optical inputs, each optical output can carry 8 audio channels at 44.1/48 kHz sample rate, four at 88.2/96 kHz or two at 176.4/192 kHz. This is an excellent method of providing multiple analogue outputs to feed a mixing console, which may be a preferred way of performing a complex mix from a large number of DAW tracks.

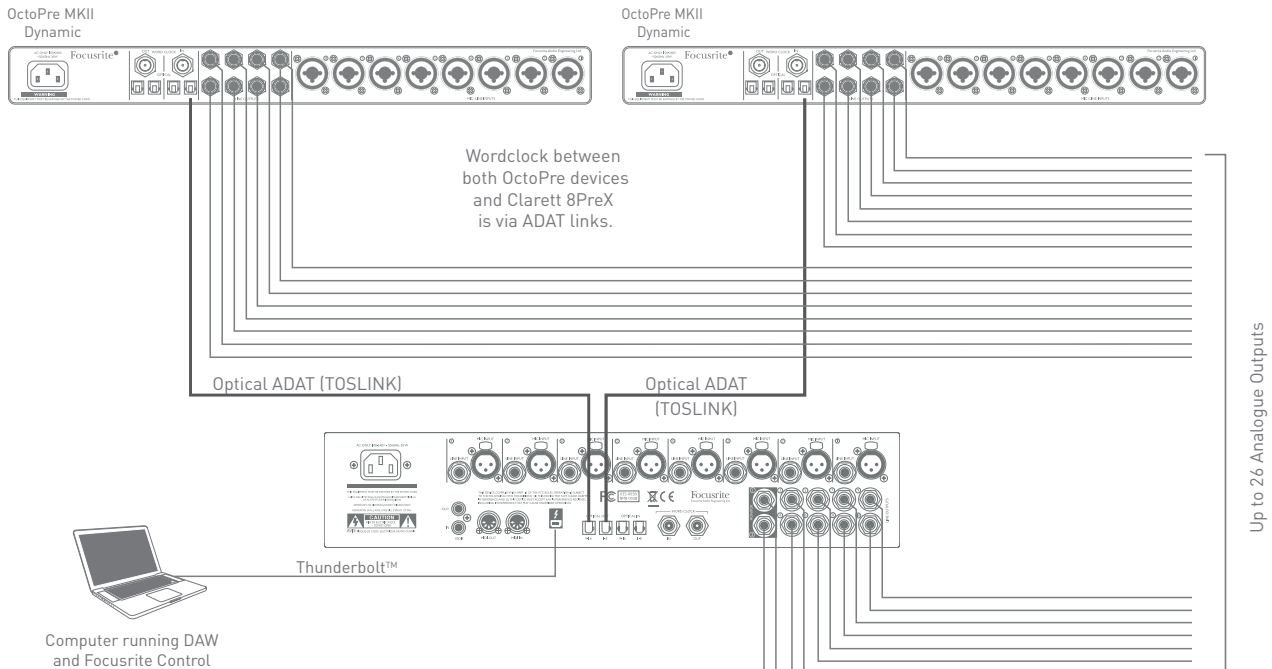

In the example, the **OPTICAL IN 1-8** ports of the two OctoPre MkII DYNAMICs are connected to the Clarett 8PreX's **OPTICAL OUT** ports with two TOSLINK optical cables. The additional outputs thus created may be routed within Focusrite Control in exactly the same manner as the other outputs.

In this situation, synchronisation is achieved by setting the Clarett 8PreX's sync source to INT (thus defining it as the sync master) and setting the sync source for both OctoPre MkII DYNAMICs to ADAT. This means that all synchronisation is via the optical links and no additional cables are required.

NOTE: when interconnecting two digital devices by any method, always ensure that both are set to use the same sample rate.

FOCUSRITE CONTROL - OVERVIEW

Focusrite Control is the software application used with the Clarett 8PreX. It allows you to create a custom monitor mix for each musician, and also to specify the routing of all audio signals to the physical audio outputs. All sample rate selection and digital sync source selection is available from Focusrite Control.

Note: Focusrite Control is a generic product, and may be used with other hardware interfaces in the Focusrite Clarett range. When you connect a Clarett interface to your computer and launch Focusrite Control, the model of interface is automatically detected, and the software configured to suit the number of inputs and outputs, and other facilities, available on the hardware.

Focusrite Control has its own, dedicated User Guide, which contains detailed operating instructions for all aspects of the software. This may be downloaded from <http://www.focusrite.com/downloads>.

CLARETT 8PreX TECHNICAL SPECIFICATIONS

Performance Specifications

Configuration	
Inputs	26: analogue (8), S/PDIF (2), ADAT (16)
Outputs	28: analogue (10), S/PDIF (2), ADAT (8)
Mixer	Fully assignable 30-in/16-out mixer
Digital Performance	
Supported sample rates	44.1 kHz, 48 kHz, 88.2 kHz, 96 kHz, 176.4 kHz & 192 kHz
Microphone Inputs	
Frequency Response	20 Hz - 20 kHz +/-0.1 dB
Dynamic Range	118 dB (A-weighted)
THD+N	0.001%
Noise EIN	-128 dBu (A-weighted)
Maximum input level	+18 dBu
Gain Range	57 dB
Line Inputs	
Frequency Response	20 Hz - 20 kHz +/-0.1 dB
Dynamic Range	116 dB
THD+N	0.005%
Maximum input level	+26 dBu
Gain Range	57 dB
Instrument Inputs	
Frequency Response	20 Hz - 20 kHz +/-0.1 dB
Dynamic Range	111 dB (A-weighted)
THD+N	0.001%
Maximum input level	+14 dBu
Gain Range	+57 dB
Line & Monitor Outputs	
Frequency Response	20 Hz - 20 kHz +/-0.1 dB
Dynamic Range (line outputs)	119 dB
Dynamic Range (monitor outputs)	117 dB
THD+N	0.0007%
Maximum Output Level (0 dBFS)	+18 dBu, balanced

Headphone Outputs	
Dynamic Range	112 dB
THD+N	0.0008%
Maximum Output Level	+16 dBu

Physical and Electrical Characteristics

Analogue Inputs 1 & 2	
Connectors	Mic: XLR sockets; Line: ¼" TRS jack, both on rear panel. Inst: ¼" TS jack on front panel
Mic/Line/Instrument switching	via Focusrite Control
Phantom power	+48 V, independently switchable per channel
Analogue Inputs 3 to 8	
Connectors	Mic: XLR sockets; Line: ¼" TRS jack, both on rear panel.
Mic/Line switching	via Focusrite Control
Phantom power	+48 V, independently switchable per channel
Analogue Outputs	
Main outputs	10 x balanced ¼" TRS jacks (on rear panel)
Stereo headphone outputs	2 x ¼" TRS jack on front panel
Main monitor output level control	On front panel
Headphones level controls	
Other I/O	
ADAT I/O	4 x TOSLINK optical connectors: 16 channels at 44.1/48 kHz 8 channels at 88.2/96 kHz 4 channels at 176.2/192 kHz
S/PDIF I/O	2 x phono (RCA); can be re-assigned to ADAT ports in software
Word clock output	BNC connector
Data connector (to computer)	1 x Thunderbolt connector
MIDI I/O	2 x 5-pin DIN sockets
Weight and Dimensions	
W x D x H	482.5 mm x 88 mm x 288 mm 19" x 3.46" x 11.34"
Weight	5.25 kg 12.13 lbs

TROUBLESHOOTING

For all troubleshooting queries, please visit the Focusrite Answerbase at www.focusrite.com/answerbase where you will find articles covering numerous troubleshooting examples.

COPYRIGHT AND LEGAL NOTICES

Focusrite is a registered trade mark and Clarett 8PreX is a trade mark of Focusrite Audio Engineering Limited.

All other trade marks and trade names are the property of their respective owners.
2015 © Focusrite Audio Engineering Limited. All rights reserved.

