

CELVIANO

EN/ES

AP-700

USER'S GUIDE GUÍA DEL USUARIO

Please keep all information for future reference.
Por favor guarde toda la documentación para futuras consultas.

Safety Precautions

Before trying to use the piano, be sure to read the separate "Safety Precautions".

Precauciones de seguridad

Antes de intentar usar el piano, asegúrese de leer las "Precauciones de seguridad" separadas.

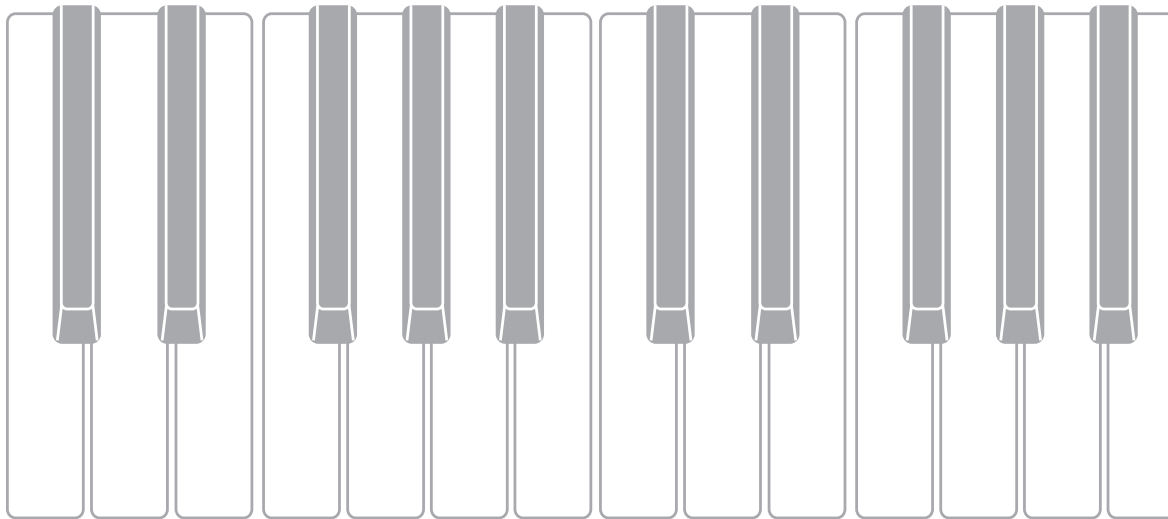

English

Español

IMPORTANT SAFETY INSTRUCTIONS

1. Read these instructions.
 2. Keep these instructions.
 3. Heed all warnings.
 4. Follow all instructions.
 5. Do not use this apparatus near water.
 6. Clean only with dry cloth.
 7. Do not block any ventilation openings. Install in accordance with the manufacturer's instructions.
 8. Do not install near any heat sources such as radiators, heat registers, stoves, or other apparatus (including amplifiers) that produce heat.
 9. Do not defeat the safety purpose of the polarized or grounding-type plug. A polarized plug has two blades with one wider than the other. A grounding type plug has two blades and a third grounding prong. The wide blade or the third prong are provided for your safety. If the provided plug does not fit into your outlet, consult an electrician for replacement of the obsolete outlet.
 10. Protect the power cord from being walked on or pinched particularly at plugs, convenience receptacles, and the point where they exit from the apparatus.
 11. Only use attachments/accessories specified by the manufacturer.
 12. Use only with the cart, stand, tripod, bracket, or table specified by the manufacturer, or sold with the apparatus. When a cart is used, use caution when moving the cart/apparatus combination to avoid injury from tip-over.
- 
13. Unplug this apparatus during lightning storms or when unused for long periods of time.
 14. Refer all servicing to qualified service personnel. Servicing is required when the apparatus has been damaged in any way, such as power-supply cord or plug is damaged, liquid has been spilled or objects have fallen into the apparatus, the apparatus has been exposed to rain or moisture, does not operate normally, or has been dropped.

The apparatus shall not be exposed to dripping or splashing and that no objects filled with liquids, such as vases, shall be placed on the apparatus.

The power indicator being unlit does not mean the apparatus is completely disconnected from the MAINS. When you need to have the apparatus completely disconnected from the MAINS, you must unplug the power cord. For that purpose, locate the apparatus in a way that secures easy access to the power cord.

NOTICE

This equipment has been tested and found to comply with the limits for a Class B digital device, pursuant to Part 15 of the FCC Rules. These limits are designed to provide reasonable protection against harmful interference in a residential installation. This equipment generates, uses and can radiate radio frequency energy and, if not installed and used in accordance with the instructions, may cause harmful interference to radio communications. However, there is no guarantee that interference will not occur in a particular installation. If this equipment does cause harmful interference to radio or television reception, which can be determined by turning the equipment off and on, the user is encouraged to try to correct the interference by one or more of the following measures:

- Reorient or relocate the receiving antenna.
- Increase the separation between the equipment and receiver.
- Connect the equipment into an outlet on a circuit different from that to which the receiver is connected.
- Consult the dealer or an experienced radio/TV technician for help.

FCC CAUTION

Changes or modifications not expressly approved by the party responsible for compliance could void the user's authority to operate the equipment.

Declaration of Conformity

Model Number: AP-700
Trade Name: CASIO COMPUTER CO., LTD.
Responsible party: CASIO AMERICA, INC.
Address: 570 MT. PLEASANT AVENUE, DOVER, NEW JERSEY 07801
Telephone number: 973-361-5400

This device complies with Part 15 of the FCC Rules, Operation is subject to the following two conditions:

(1) This device may not cause harmful interference, and (2) this device must accept any interference received, including interference that may cause undesired operation.

Important!

Please note the following important information before using this product.

- Before using the AD-E24500LW Adaptor to power the unit, be sure to check the AC Adaptor for any damage first. Carefully check the power cord for breakage, cuts, exposed wire and other serious damage. Never let children use an AC adaptor that is seriously damaged.
- The product is not intended for children under 3 years.
- Use only CASIO AD-E24500LW adaptor.
- The AC adaptor is not a toy.
- Be sure to disconnect the AC adaptor before cleaning the product.

Declaration of Conformity According to EU Directive

 Manufacturer:
CASIO COMPUTER CO., LTD.
6-2, Hon-machi 1-chome, Shibuya-ku, Tokyo 151-8543, Japan
Responsible within the European Union:
Casio Europe GmbH
Casio-Platz 1, 22848 Norderstedt, Germany
www.casio-europe.com

Contents

Getting Ready	EN-55
Assembling the Stand	EN-55
To connect the cables	EN-58
Keyboard Cover	EN-59
To install the music stand and headphones hook	EN-59
Opening and Closing the Piano Lid	EN-60
Removing the Protective Tape from the Keyboard	EN-61
Power Outlet	EN-61
Connecting Headphones	EN-62
Connecting Audio Equipment or an Amplifier	EN-62
Bundled and Optional Accessories	EN-63

General Guide **EN-4**

Power Outlet **EN-6**

Turning Power On or Off	EN-6
Auto Power Off	EN-6
Adjusting the Volume Level	EN-6
Adjusting Display Contrast	EN-7
Returning the Digital Piano to Its Factory Default Settings	EN-7
Operation Lock	EN-7

Operations Common to All Modes **EN-8**

About the Home Screen	EN-8
Navigating Between Setting Screens	EN-8
Selecting an Item (Parameter) to Change Its Setting	EN-8
Changing a Number or a Value	EN-8
To scroll a number sequentially	EN-8
To fast scroll a number	EN-8
Setting Shortcut Menus	EN-9
Starting and Stopping Playback	EN-9
To repeat play a specific section of a song	EN-9

Playing with Different Tones **EN-10**

Selecting and Playing a Tone	EN-10
To select a tone in a tone group	EN-10
To use the tone list to select a tone	EN-10
Using the Digital Piano's Pedals	EN-11
To adjust the half pedal trigger position	EN-11
Adjusting Acoustic Piano Sound Characteristics	EN-12
Using Effects	EN-13
To apply a hall simulator	EN-13
To select a listening position	EN-13
To apply chorus to a tone	EN-14
To adjust brilliance	EN-14
About DSP	EN-14
Splitting the Keyboard for Duet Play	EN-14
To change the octaves of the duet keyboards	EN-15
Layering Two Tones	EN-16
To adjust the volume balance between two layered tones	EN-16
To change the octave of each layer	EN-17

Splitting the Keyboard between Two Different Tones	EN-17
To modify split settings	EN-18
Using the Metronome	EN-19
To start and stop	EN-19
To adjust the tempo	EN-19
To configure metronome settings	EN-19
Changing Keyboard Response to Touch Pressure (Touch Response)	EN-20
To change touch response sensitivity	EN-20
Changing the Pitch (Transpose, Tuning, Octave Shift)	EN-20
To change the pitch in semitone steps (Transpose)	EN-20
Fine Tuning (Tuning)	EN-21
To change the tuning curve (Stretch Tuning)	EN-21
Octave Shift	EN-22
Changing the Temperament of the Keyboard	EN-22

Using Built-in Songs (Concert Play, Music Library) **EN-23**

Concert Play	EN-23
To listen to a Concert Play Song (Listen Mode)	EN-23
To play along with an orchestra using Concert Play (Play Mode)	EN-24
To adjust the playback volume level of a Concert Play song	EN-25
Concert Play Songs Obtained with a Computer, etc.	EN-25
To save Concert Play songs obtained with a computer, etc. to a USB flash drive	EN-25
To play back Concert Play songs obtained with a computer, etc.	EN-25
Music Library	EN-25
To play back a specific music library song	EN-26
To practice with a music library song	EN-26
Playing Back Song Data Stored on a USB Flash Drive	EN-27
To adjust the playback volume level of song data	EN-27

Demo Song **EN-28**

Performing Demo Play	EN-28
Comparing Grand Piano Tones	EN-29

Recording and Playback EN-30

MIDI Recorder	
(Recording to Digital Piano Memory)	EN-32
To record to a specific song track	EN-32
To record the other track of a song	EN-33
To configure precount settings	EN-33
To play back from Digital Piano memory	EN-34
To adjust the playback volume level of a MIDI Recorder song	EN-34
To delete recorded data	EN-34
Audio Recorder	
(Recording to a USB Flash Drive)	EN-35
To record keyboard play to a USB flash drive	EN-35
To record keyboard play while playing back a MIDI Recorder song or song data	EN-36
To play back data recorded on a USB flash drive	EN-36
To adjust the Audio Recorder volume level	EN-36
To delete the currently selected Audio Recorder song data	EN-37

Configuring Digital Piano Settings EN-38

Configuring Settings	EN-38
Parameter List	EN-39

USB Flash Drive EN-44

Preparing a USB Flash Drive	EN-45
Supported USB Flash Drives	EN-45
Data Types Supported by the Digital Piano	EN-46
To connect a USB flash drive to and to detach it from the Digital Piano	EN-47
To format a USB flash drive	EN-48
Saving Standard Song Data to a USB Flash Drive	EN-48
Saving Digital Piano Data to a USB Flash Drive	EN-49
Loading USB Flash Drive Data into Digital Piano Memory	EN-50
Deleting USB Flash Drive File	EN-51
Renaming a USB Flash Drive File	EN-51
Error Indicators	EN-52

Connecting to a Computer EN-53

Minimum Computer System Requirements	EN-53
Connecting the Digital Piano to Your Computer	EN-53
Using MIDI	EN-54
What is MIDI?	EN-54

Troubleshooting EN-64**Reference EN-66**

Product Specifications	EN-66
Operating Precautions	EN-68



Appendix A-1

Tone List	A-1
Concert Play List	A-2
Music Library List	A-3
Grand Piano Demo Song List	A-3





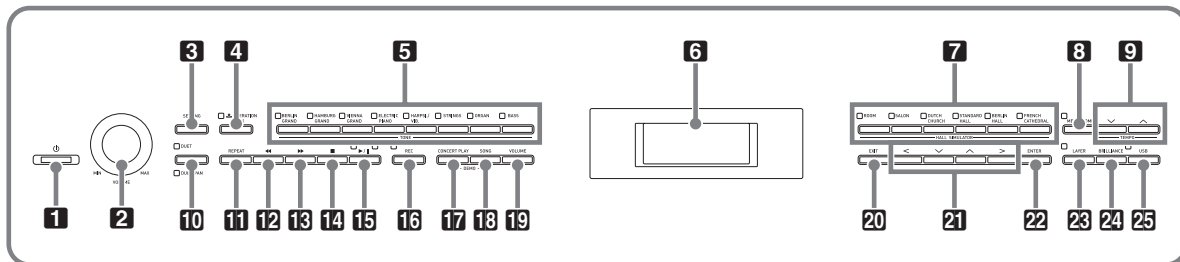

MIDI Implementation Chart

- Any reproduction of the contents of this manual, either in part or its entirety, is prohibited. Except for your own, personal use, any other use of the contents of this manual without the consent of CASIO is prohibited under copyright laws.
- IN NO EVENT SHALL CASIO BE LIABLE FOR ANY DAMAGES WHATSOEVER (INCLUDING, WITHOUT LIMITATION, DAMAGES FOR LOSS OF PROFITS, BUSINESS INTERRUPTION, LOSS OF INFORMATION) ARISING OUT OF THE USE OF OR INABILITY TO USE THIS MANUAL OR PRODUCT, EVEN IF CASIO HAS BEEN ADVISED OF THE POSSIBILITY OF SUCH DAMAGES.
- The contents of this manual are subject to change without notice.
- The actual appearance of the product may be different from that shown in the illustrations in this User's Guide.
- Company and product names used in this manual may be registered trademarks of others.

General Guide

- The following explains the meaning of the  symbol that appears on the product console and with the key names below.
-  : Indicates a function that is enabled by holding down the button for some time.
- The names shown here are always indicated in bold when they appear within the text of this manual.



- | | |
|---|--|
| 1  (Power) button | 14  (Stop) button |
| 2 VOLUME controller | 15  (Start/pause) button |
| 3 SETTING button | 16 REC button |
| 4 OPERATION LOCK  button | 17 CONCERT PLAY button |
| 5 Tone group buttons | 18 SONG button |
| 6 LCD display | 19 VOLUME button |
| 7 HALL SIMULATOR buttons | 20 EXIT button |
| 8 METRONOME button | 21 Arrow buttons |
| 9 TEMPO buttons | 22 ENTER button |
| 10 DUET button | 23 LAYER button |
| 11 REPEAT button | 24 BRILLIANCE button |
| 12  (Rewind) button | 25 USB button |
| 13  (Fast Forward) button | |

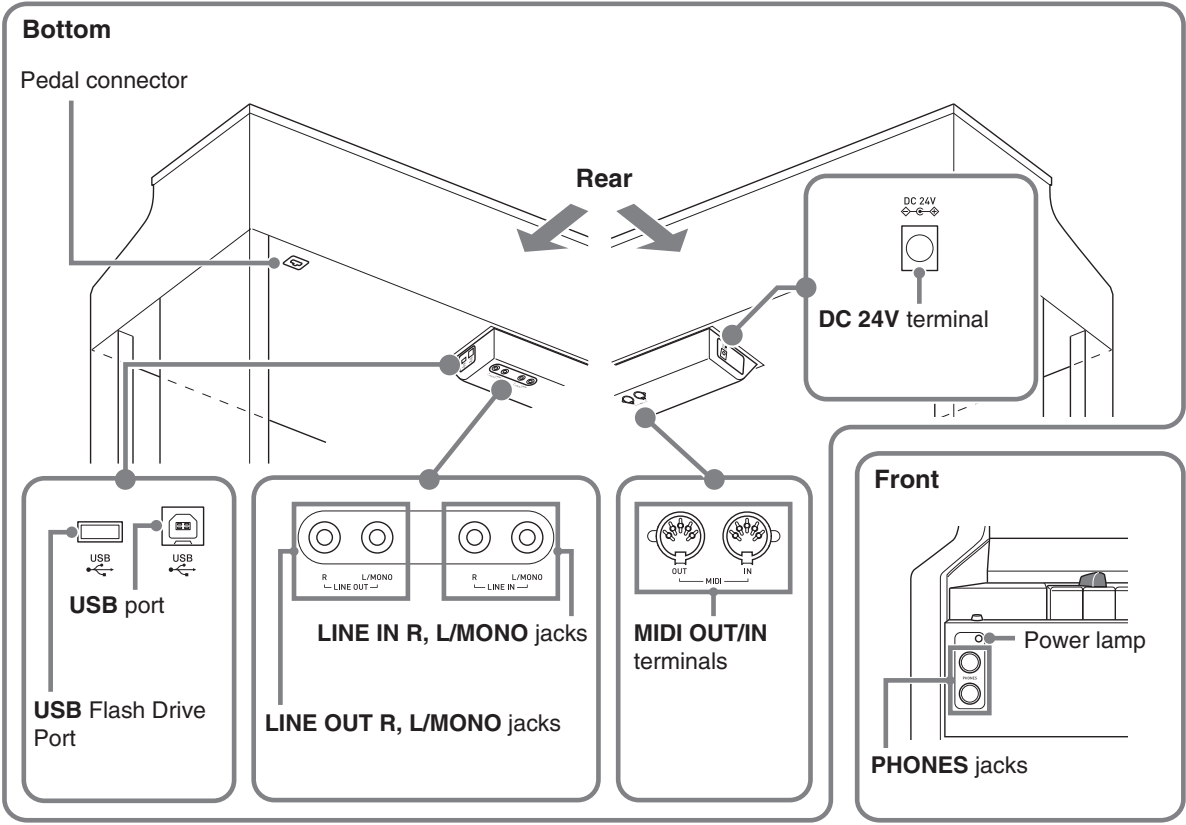





Power Outlet

After you finish assembling the stand, turn on the Digital Piano. For details, see “Getting Ready” on page EN-55.

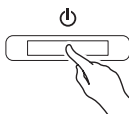
Turning Power On or Off

1. Press the **1**  (Power) button to turn on Digital Piano power.



- This causes the **1**  (Power) button to light.
- If you press **1**  (Power) button only lightly, the display will light up momentarily but power will not turn on. This does not indicate malfunction. Press **1**  (Power) button firmly and completely to turn on power.

2. To turn off the Digital Piano, hold down the **1**  (Power) button until its light goes out.

NOTE

- You can configure the Digital Piano to save its setup when power is turned off. For details, see “Configuring Digital Piano Settings” on page EN-38, and “General” → “Auto Resume” in the “Parameter List” on page EN-42.

IMPORTANT!



- Pressing the **1**  (Power) button to turn off power actually puts the Digital Piano into a standby state. Minute amounts of current continue to flow within the Digital Piano in the standby state. If you do not plan to use the Digital Piano for a long time or if there is a lightning storm in your area, be sure to unplug the AC adaptor from the power outlet.
- The message “Please Wait...” will remain on the display while a data save operation is in progress. Do not perform any other operation while it is displayed. Turning off the Digital Piano can cause Digital Piano data to be deleted or become corrupted.

Auto Power Off





This Digital Piano is designed to turn off automatically to avoid wasting power after no operation is performed for a preset amount of time. The Auto Power Off trigger time is about four hours.

- You also can use the procedure below to temporarily suspend Auto Power Off.

To disable Auto Power Off

1. Press the **3** **SETTING** button to display the setting screen.
2. Use the **21**  and  arrow buttons to select “General” and then press the **22** **ENTER** button.

● *General* > Ent

3. Use the **21**  and  arrow buttons to select “Auto Power Off”.
4. Use the **21**  and  arrow buttons to select “Off”.
5. Press the **3** **SETTING** button to exit the setting screen.

NOTE

- To re-enable Auto Power Off, perform the above procedure and select “On” in step 4.







Adjusting the Volume Level

1. Use the **2** **VOLUME** controller to adjust the volume.

NOTE

- Your Digital Piano has a Volume Sync Equalizer feature that automatically enhances tone quality in accordance with the volume level. This feature ensures that low range and/or high range sounds are easier to hear, even at low volume levels. For details, see “General” → “Volume Sync EQ” in the “Parameter List” (page EN-39).

Adjusting Display Contrast

1. Press the **3** **SETTING** button to display the setting screen.
2. Use the **21**  and  arrow buttons to select “General” and then press the **22** **ENTER** button.
3. Use the **21**  and  arrow buttons to select “LCD Contrast”.
4. Use the **21**  (-) and  (+) arrow buttons to adjust display contrast.
 - The contrast setting range is 0 to 26.
5. Press the **3** **SETTING** button to exit the setting screen.

Returning the Digital Piano to Its Factory Default Settings

Perform the following procedure when you want to return the Digital Piano’s stored data and settings to their initial factory defaults.

1. Press the **3** **SETTING** button to display the setting screen.
2. Use the **21**  and  arrow buttons to select “General” and then press the **22** **ENTER** button.
3. Use the **21**  and  arrow buttons to select “Factory Reset” and then press the **22** **ENTER** button.
 - This causes the confirmation message “Initialize All?” to appear.
4. Press the **22** **ENTER** button.
 - This will cause the confirmation message “Sure?” to appear.
5. Press the **21**  arrow button to execute the initialize operation.
 - To cancel the initialize operation, press the **21**  arrow button.
 - The message “Please Wait...” will remain on the display while the operation is being performed. Do not perform any operation while this message is on the display. “Complete!” appears on the display after the operation is complete.

Operation Lock

Enable this setting when you want to protect against unintentional button operations.

It locks most of the Digital Piano’s buttons, so their operations are disabled.

Only operation of the **1**  (Power) and

4 **OPERATION LOCK** buttons remain enabled.

1. Hold down the **4** **OPERATION LOCK** button until its lamp lights.
2. To unlock operations, press the **4** **OPERATION LOCK** button again.
 - This will cause the lamp above the button to go out.

Operations Common to All Modes

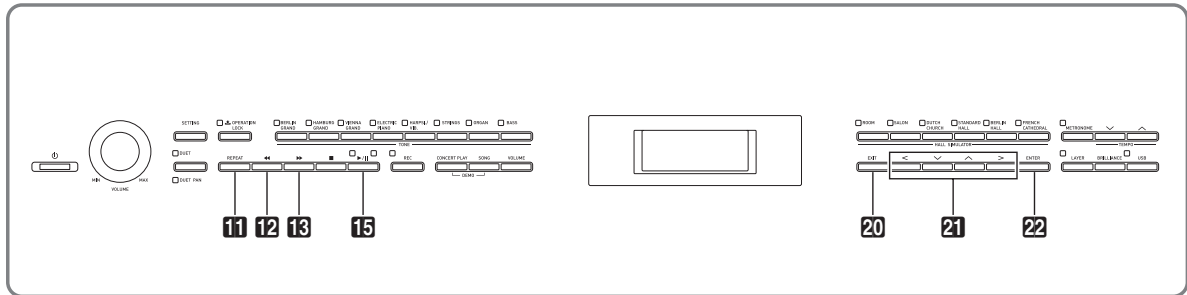

The operations described in this section are common to all modes and functions.

About the Home Screen

Turning on the Digital Piano displays a screen that shows the name of the current selected tone. This is the Home Screen.



- After performing operations, you can navigate back to the home screen by pressing the **20**EXIT button.

Navigating Between Setting Screens

If a display item has ">Ent" to the right of it, it means that pressing the **22**ENTER button will display a submenu.

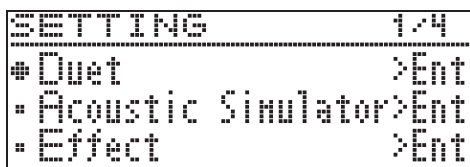

- To navigate back to a previous screen, press the **20**EXIT button.

Selecting an Item (Parameter) to Change Its Setting

A dot (●) or arrow (▶) mark to the left of a parameter name indicates that the parameter is selected.

1. Use the **21**▼ and ▲ arrow buttons to move the mark up or down.

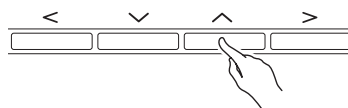

- Holding down either button moves the mark at high speed.

Changing a Number or a Value

Use the operations in this section to specify a number or to change a value.

To scroll a number sequentially

1. Press the **21**< (-) or > (+) arrow button.

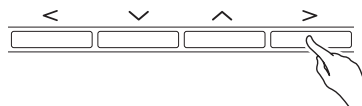

- To return a setting to its initial default, press the **21**< and > arrow buttons at the same time.

To fast scroll a number

1. Hold down the **21**< (-) or > (+) arrow button.

Setting Shortcut Menus

Holding down a button displays a menu of functions and/or tones like the one shown below to appear. The content of the menu depends on the button that is held down.

Button Name	Shortcut Menu Contents	More Information
DUET	Duet settings	"Splitting the Keyboard for Duet Play", page EN-14
CONCERT PLAY	Concert Play volume level setting	"To adjust the playback volume level of a Concert Play song", page EN-25
SONG	Song data settings	"Song >Ent" in the "Parameter List", page EN-41
LAYER	Layer settings	"Layering Two Tones", page EN-16
REC	MIDI Recorder and Audio Recorder settings	"Recording and Playback", page EN-30
METRONOME	Metronome settings	"To configure metronome settings", page EN-19
BERLIN GRAND	BERLIN GRAND tone demo songs	"Performing Demo Play", page EN-28
HAMBURG GRAND	HAMBURG GRAND tone demo songs	
VIENNA GRAND	VIENNA GRAND tone demo songs	

Starting and Stopping Playback

Use the procedure below with functions that allow playback of data.

PREPARATION

- Select the song you want to play back.
 - Concert Play: "To listen to a Concert Play Song (Listen Mode)" (page EN-23)
 - Music Library: "To play back a specific music library song" (page EN-26)
 - MIDI Recorder: "To play back from Digital Piano memory" (page EN-34)
 - Audio Recorder: "To play back data recorded on a USB flash drive" (page EN-36)

1. Press the **15** ▶/|| button to start playback.

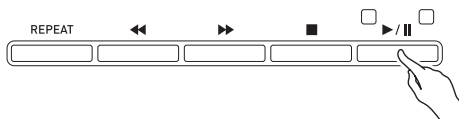

- Holding down the **12** ◀◀ button during playback fast reverses the track.
 - Holding down the **13** ▶▶ button during playback fast forwards the track.
 - Press and releasing the **12** ◀◀ button causes playback to jump to the beginning of the track.
2. Press the **15** ▶/|| button to pause playback.
 - Press the **15** ▶/|| button again to resume playback.
 - You can use the procedure in the next section to repeat play a specific section of a song.

To repeat play a specific section of a song

- This procedure is not supported during demo song play (page EN-28).
1. While a tune is playing, press the **11** REPEAT button at when the beginning of the section you want to repeat (Point A) is reached.
 - This causes "A" to flash on the display.
 - This will cause the **11** REPEAT button to flash.
 2. Press the **11** REPEAT button again at when the end of the section you want to repeat (Point B) is reached.
 - This causes "B" to flash on the display along with "A".
 - This will cause the **11** REPEAT button to stop flashing and remain lit.
 - Repeat playback of the section from Point A to Point B starts automatically.
 - Holding down the **12** ◀◀ button during repeat playback jumps to Point A. Holding down the **13** ▶▶ button during playback jumps to Point B.
 3. To exit repeat playback, press the **11** REPEAT button.
 - This will cause "A" and "B" to stop flashing on the display.

Playing with Different Tones

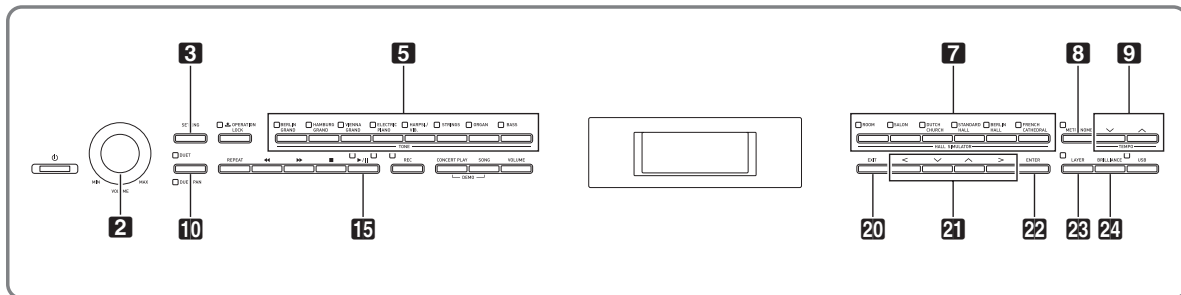

Your Digital Piano has 26 built-in tones, which include those of the world-renowned grand pianos. It also has a Hall Simulator and other features (page EN-13) that let you add effects that give you the feel of playing in one of the world's famous concert halls.

Selecting and Playing a Tone

Use either of the two procedures below to select a tone.

- Select a tone in a tone group
- Select a tone in the tone list

NOTE

- For information about tone group names and the names of the tones in each group, see the "Tone List" (page A-1).

Tone List

Tone List/ Lista de tonos		
Tone Group/ Grupo de tonos	No./ N°	Tone Name/ Nombre de tonos
STRINGS	01	BERLIN GRAND
STRINGS	02	PARIS GRAND
STRINGS	03	VIENNA GRAND
STRINGS	04	VIENNA GRAND
STRINGS	05	VIENNA GRAND
STRINGS	06	VIENNA GRAND
STRINGS	07	VIENNA GRAND
STRINGS	08	VIENNA GRAND
STRINGS	09	VIENNA GRAND
STRINGS	10	VIENNA GRAND
STRINGS	11	VIENNA GRAND
STRINGS	12	VIENNA GRAND
STRINGS	13	VIENNA GRAND
STRINGS	14	VIENNA GRAND
STRINGS	15	VIENNA GRAND
STRINGS	16	VIENNA GRAND
STRINGS	17	VIENNA GRAND
STRINGS	18	VIENNA GRAND
STRINGS	19	VIENNA GRAND
STRINGS	20	VIENNA GRAND
STRINGS	21	VIENNA GRAND
STRINGS	22	VIENNA GRAND
STRINGS	23	VIENNA GRAND
STRINGS	24	VIENNA GRAND

To select a tone in a tone group

1. Press one of the **5** Tone Group buttons below.

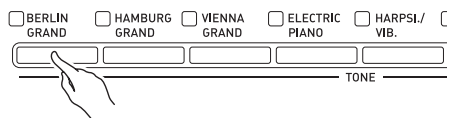

- The lamp of the button you press will light, and the name of the tone will appear on the display.
- Pressing the button of the tone group that is currently selected scrolls through the group tones without leaving the group.

To use the tone list to select a tone

With this method, all of the Digital Piano's tones are included in the list, including those not assigned to a tone group button.

1. On the home screen (page EN-8), use the **21** ∇ and \wedge arrow buttons to select the tone name you want.

- The pointer (\blacktriangleright) indicates the name of the currently selected tone. Pressing a keyboard key plays the selected tone.

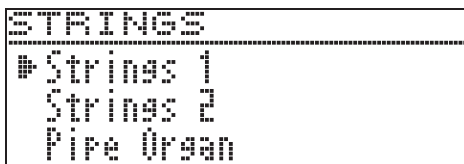

- The pointer (\blacktriangleright) does not stay in any particular tone group.
- Holding down the **21** ∇ or \wedge arrow button scrolls through tone names at high speed.
- You can use the **21** \leftarrow and \rightarrow arrow buttons to select a tone group.
- To return to tone number 01 (BERLIN GRAND), press the **21** ∇ and \wedge arrow buttons at the same time.

2. Press the **22** ENTER button to apply the currently selected tone.

- The currently selected tone will also be applied automatically if you do not perform any button operation for about ten seconds in step 1.

Using the Digital Piano's Pedals

Your Digital Piano comes equipped with three pedals: damper, soft, and sostenuto

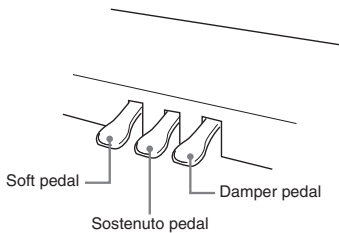

Pedal Functions

Damper Pedal

Pressing the damper pedal while playing will cause the notes you play to reverberate.

- When grand piano is selected as the tone, using this pedal generates harmonic and other resonance, just like the damper pedal on an acoustic grand piano. Half-pedal operation (pressing the pedal part way) is also supported.

Soft Pedal

Pressing this pedal while playing suppresses notes played on the keyboard after the pedal was pressed, and makes them sound softer.

Sostenuto Pedal

Only the notes of the keys that are depressed when this pedal is pressed are sustained, even if the keyboard keys are released, until the pedal is released.

NOTE

- If pressing the pedal does not produce the desired effect, it could mean that the pedal cord is not connected properly. Refer to step 2 under "To connect the cables" (page EN-59).

To adjust the half pedal trigger position

1. Press the **3** **SETTING** button to display the setting screen.

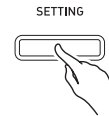

2. Use the **21** **∨** and **∧** arrow buttons to select "General" and then press the **22** **ENTER** button.
3. Use the **21** **∨** and **∧** arrow buttons to select "Half Pedal Pos."

● *Half Pedal Pos.*

4. Use the **21** **<** (-) and **>** (+) arrow buttons to change the setting value and adjust the half pedal trigger position.
 - +1 or greater: Deeper trigger position
 - -1 or less: Shallower trigger position
 - The setting range is -2 to +2.
5. Press the **3** **SETTING** button to exit the setting screen.

Adjusting Acoustic Piano Sound Characteristics

The tones of your Digital Piano have built-in elements that give them the characteristic reverberation of an acoustic piano. Each of these elements can be individually adjusted as described below.

Display Name	Description	Setting Range
Hammer Response	<p>Hammer Response. The size of the hammers that strike the strings in an acoustic piano changes according to the key range, so the timing of note sounding also changes with the range. This settings lets you select timing of note sounding.</p> <ul style="list-style-type: none"> • Default: Optimum setting for currently selected tone. • Off: Fastest response across entire keyboard, regardless of range. • 1 to 10: A greater value produces slower timing. 	D (Default), Off (Disabled), 1 to 10
Lid Simulator	<p>Lid Simulator. Timbre changes depending on how much the lid of an acoustic piano is open. You can select one of the lid opening settings described below.</p> <ul style="list-style-type: none"> • Default: Optimum setting for currently selected tone. • Closed: Lid closed. • Semi (Semi-open): Lid partially open. • Full (Full-open): Lid fully open. • Removed: Lid removed. 	D (Default), Closed, Semi, Full, Removed
Damper Resonance	<p>Damper Resonance. Pressing the damper pedal on an acoustic piano opens all 88 of the strings, causing all of the strings that are harmonics of the strings that are played to resonate. You can select one of the resonance settings described below.</p> <ul style="list-style-type: none"> • Default: Optimum setting for currently selected tone. • Off (Disabled), 1 to 10: A larger value increases the effect level. 	D (Default), Off (Disabled), 1 to 10
Damper Noise	<p>Damper Noise. Damper noise is a slight metallic ringing sound that is generated as the damper of an acoustic piano separates from the wires pedal when the damper pedal is pressed. You can use the settings below to adjust the volume level of damper noise.</p> <ul style="list-style-type: none"> • Default: Optimum setting for currently selected tone. • Off (Disabled), 1 to 10: A larger value increases the noise level. 	D (Default), Off (Disabled), 1 to 10
String Resonance	<p>String Resonance. Playing on an acoustic piano causes the strings that are harmonics of the played strings to resonate. You can select one of the resonance settings described below.</p> <ul style="list-style-type: none"> • Default: Optimum setting for currently selected tone. • Off (Disabled), 1 to 10: A larger value increases the resonance level. 	D (Default), Off (Disabled), 1 to 10

1. Press the **3**SETTING button to display the setting screen.

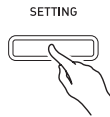

2. Use the **21**∨ and ∧ arrow buttons to select "Acoustic Simulator" and then press the **22**ENTER button.

● Acoustic Simulator > Ent

3. Use the **21**∨ and ∧ arrow buttons to select the item you want to adjust.
4. Use the **21**< (-) and > (+) arrow buttons to change the setting.
5. Press the **3**SETTING button to exit the setting screen.

Using Effects

Hall Simulator

Simulates the rich clarity, unconstrained brilliance, and other acoustic distinctive characteristics of world-famous concert halls.

- Timbre and reverberation change depending on the position in the concert hall where the listener is located. Hall Simulator can simulate listening at any position within the currently selected hall.
- Disabling Hall Simulator also disables the Hall effect.

Chorus

Adds more breadth to your notes.

Brilliance

Effect for adjusting the brilliance of the tone.

To apply a hall simulator

1. Press one of the **7**HALL SIMULATOR buttons to select a hall simulator.

Number	Hall simulator Name	Description
1	ROOM	Room
2	SALON	Salon
3	DUTCH CHURCH	Amsterdam church with acoustics that are suitable for music
4	STANDARD HALL	Standard concert hall
5	BERLIN HALL	Berlin arena type classic concert hall
6	FRENCH CATHEDRAL	Large gothic cathedral in Paris

- The lamp of the button you press will light.
2. To turn off the hall simulator, press the same button you pressed in step 1.
 - This will cause the lamp of the button to become unlit.

To select a listening position

1. Press the **3**SETTING button to display the setting screen.
2. Use the **21**∨ and ∧ arrow buttons to select "Effect" and then press the **22**ENTER button.
3. Use the **21**∨ and ∧ arrow buttons to select "Position".

● Position

4. Use the **21**< and > arrow buttons to select a position.
 - Player: Position of the performer seated in front of the piano on the stage of the hall
 - Listener 1: Position of audience seated at the front of the hall
 - Listener 2: Position of audience seated further back than Listener 1
 - Listener 3: Position of audience seated further back than Listener 2
5. Press the **3**SETTING button to exit the setting screen.

To apply chorus to a tone

1. Press the **3** **SETTING** button to display the setting screen.
2. Use the **21** \downarrow and \uparrow arrow buttons to select "Effect" and then press the **22** **ENTER** button.
3. Use the **21** \downarrow and \uparrow arrow buttons to select "Chorus".

● *Chorus*

4. Use the **21** \leftarrow and \rightarrow arrow buttons to select a chorus name.

Display	Setting
Off	Off (OFF)
Light Chorus	Light Chorus
Chorus	Medium Chorus
Deep Chorus	Deep Chorus
Flanger	Flanger (whooshing effect)

5. Press the **3** **SETTING** button to exit the setting screen.

To adjust brilliance

1. Press the **24** **BRILLIANCE** button to display the setting screen.

● *Brilliance*

2. Use the **21** \leftarrow (-) and \rightarrow (+) arrow buttons to change the setting.
 - +1 or higher: Makes the tone brighter.
 - -1 or lower: Makes the tone darker.
 - The setting range is -3 to +3.
3. Press the **20** **EXIT** button to exit the setting screen.

About DSP

DSP makes it possible to digitally produce complex acoustic effects. The DSP is assigned to each tone whenever you turn on Digital Piano power.

Splitting the Keyboard for Duet Play

You can split the keyboard in the center for duet play so the left and right sides have the same ranges. The left pedal operates as the left side damper pedal, while the right pedal is the right side damper pedal. The Duet Mode is the perfect way to conduct lessons, with the teacher playing on the left side as the student playing the same song on the right side.

Keyboard

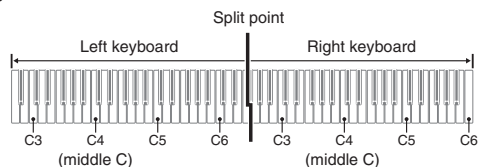

Pedals

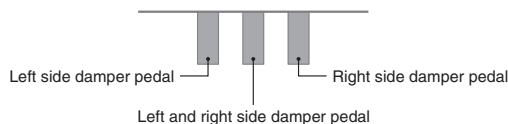



NOTE

- Only the damper pedal for the right side keyboard supports half-pedal operations.

1. Specify the number of the tone you want to use.
 - See "Selecting and Playing a Tone" on page EN-10 for information about how to select a tone.

2. Each press of the **10**DUET button cycles the duet setting between the settings below.

<input checked="" type="checkbox"/> DUET  <input type="checkbox"/> DUET PAN	Enabled (Both left and right keyboard sounds are input from the left and right speakers.)
<input type="checkbox"/> DUET  <input checked="" type="checkbox"/> DUET PAN	Enabled (Left side keyboard play is output from the left speaker and right side play is output from the right speaker. The Duet Pan Mode effect is applied only while a grand piano tone is selected.)
<input type="checkbox"/> DUET  <input type="checkbox"/> DUET PAN	Disabled

- Turning on layer (page EN-16) automatically exits the Duet Mode.
- Note that Layer (page EN-16), Transpose (page EN-20), and normal Octave Shift (page EN-22) cannot be selected while duet is enabled. You can use the procedure under “To change the octaves of the duet keyboards” below to change the octaves of the duet keyboards.
- The effects below are not applied while the DUET PAN lamp is lit.
 - Acoustic Simulator (except for Hammer Response and Lid Simulator) (page EN-12)
 - Hall Simulator (page EN-13)
 - Chorus (page EN-14)

To change the octaves of the duet keyboards

You can change the ranges of the left and right keyboards in octave units from their initial default settings.

1. Hold down the **10**DUET button until the screen shown below appears.

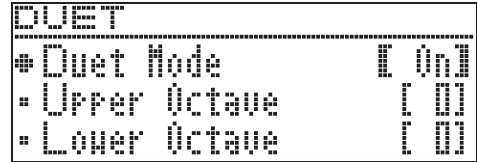

2. Use the **21** ∇ and \wedge arrow buttons to select a keyboard range.

- Upper Octave: Right-side keyboard
- Lower Octave: Left-side keyboard

● Lower Octave

3. Use the **21** \leftarrow (-) and \rightarrow (+) arrow buttons to change the octave.

- +1 or higher: Raises the octave by the specified value.
- -1 or lower: Lowers the octave by the specified value.
- 0: Returns the octave to its original setting.
- The setting range is -2 to +2.
- Example: To select “Lower Octave” in step 2 and set “+1” in step 3

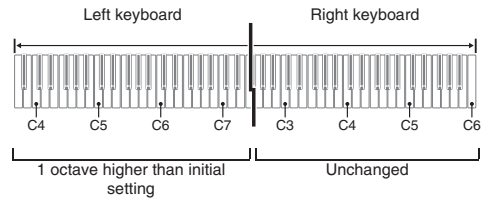

4. Press the **20**EXIT button to exit the setting screen.

Layering Two Tones

Use the following procedure to layer two tones, so they sound at the same time.

1. Press the **23**LAYER button.

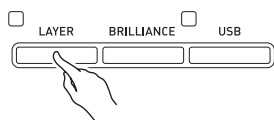

2. Use the **21**< and > arrow buttons to display “LAYER”.

LAYER		
#U1: Berlin Grand	>Ent	
U2: Strings 1	>Ent	
L: ---	>Ent	

3. Select the main tone.

- Use the **21**∨ and ∧ arrow buttons to select “U1” (Upper 1) and then press the **22**ENTER button.

▶ U1

4. Select a tone and then press the **22**ENTER button.

- See “Selecting and Playing a Tone” on page EN-10 for information about how to select a tone.

5. Select the layered tone.

- Use the **21**∨ and ∧ arrow buttons to select “U2” (Upper 2) and then press the **22**ENTER button.

▶ U2

6. Select a tone and then press the **22**ENTER button.

7. Press a keyboard key.

- Both tones sound at the same time.

8. To cancel layering and switch to a single tone (Upper 1), press the **23**LAYER button or **20**EXIT button.

- Each press of the **23**LAYER button toggles between unlayered (one tone) and layered (two tones).
- Two tone output is enabled while the **23**LAYER button lamp is lit.
- Entering the Duet Mode (page EN-14) or Duet Pan Mode will disable layering.

NOTE

- Configuring of layering settings is not supported by MIDI Recorder Track 2 recording.

To adjust the volume balance between two layered tones

1. Hold down the **23**LAYER button until the screen shown below appears.

LAYER/SPLIT	1/3
#Upper1 Octave	[0]
#Upper2 Octave	[0]
#Layer Balance	[-10]

2. Use the **21**∨ and ∧ arrow buttons to select “Layer Balance”.

● Layer Balance

3. Use the **21**< (-) and > (+) arrow buttons to adjust the layer volume balance.

- -1 or lower: Increases the Upper 1 tone volume.
- +1 or higher: Increases the Upper 2 tone volume.
- 0: Upper 1 and Upper 2 volume the same.
- The setting range is -24 to +24.

4. To return to the screen you were at prior to step 1 of this procedure, press **20**EXIT button.

To change the octave of each layer

You can use the procedure below to change the octave of each layer.

1. Hold down the **23**LAYER button until the screen shown below appears.

LAYER/SPLIT	1/3
• Upper1 Octave	[01]
• Upper2 Octave	[01]
• Layer Balance	[-10]

2. Use the **21** \vee and \wedge arrow buttons to select the layer whose octave you want to change.
 - Upper 1: Select "Upper1 Octave"
Upper 2: Select "Upper2 Octave".
3. Use the **21** \lt (-) and \gt (+) arrow buttons to change the octave.
 - +1 or higher: Raises the octave by the specified value.
 - -1 or lower: Lowers the octave by the specified value.
 - 0: Returns the octave to its original setting.
 - The setting range is -2 to +2.
4. To return to the screen you were at prior to step 1 of this procedure, press **20**EXIT button.

Splitting the Keyboard between Two Different Tones

You can use the procedure below to assign different tones to the right range and left range of the keyboard, so it sounds like you are playing an ensemble between two instruments.

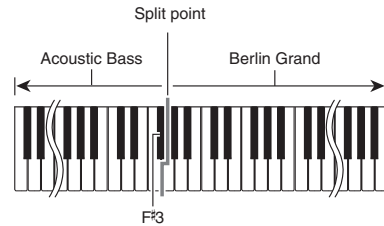

NOTE

- If you turn on both layer and split, layering will be applied to the right side range of the keyboard only.
- Use of the Duet Mode (page EN-14) is recommended to divide the keyboard in the center between a left keyboard and right keyboard of identical ranges.

1. Press the **23**LAYER button.
2. Use the **21** \lt and \gt buttons to display "SPLIT".

4SPLITM		
#U1: Berlin Grand		>Ent
U2: ---		>Ent
L: Acoustic Bass		>Ent



- To use both keyboard split and keyboard layering, display "LAYER&SPLIT".

4LAYER&SPLITM		
#U1: Berlin Grand		>Ent
U2: Strings 1		>Ent
L: Acoustic Bass		>Ent

3. Select a tone for the left keyboard.
 - Use the **21** \vee and \wedge arrow buttons to select "L" (Lower) and then press the **22**ENTER button.

▶ L



4. Select a tone and then press the **22**ENTER button.
 - See "Selecting and Playing a Tone" on page EN-10 for information about how to select a tone.

5. Select the tone for the right side range.
 - Use the **21**  and  arrow buttons to select “U1” and then press the **22** **ENTER** button.
6. Select a tone and then press the **22** **ENTER** button.
 - If you want to use layering for the right keyboard (page EN-16), repeat steps 5 and 6 to select the “U2” (Upper 2) tone.
7. Press a keyboard key.
 - This will sound the tones assigned to the left and right side ranges of the keyboard.
8. To cancel the split keyboard and switch to a single tone (Upper 1), press the **23** **LAYER** button or **20** **EXIT** button.
 - Each press of the **23** **LAYER** button toggles between unlayered (one tone) and layered (two tones).
 - Two tone output is enabled while the **23** **LAYER** button lamp is lit.

To modify split settings

1. Hold down the **23** **LAYER** button until the screen shown below appears.

LAYER/SPLIT	1/3
* Upper1 Octave	[0]
* Upper2 Octave	[0]
* Layer Balance	[-10]

2. Use the **21**  and  arrow buttons to select an item.

Display Name	Description	Setting Range
Lower Octave	Lower Octave. Changes the octave of the left (Lower) side of a split keyboard in one-octave units. A value that is 1 or higher raises by the specified number of octaves, while a value that is -1 or lower lowers by the specified number of octaves.	-2 to +2
Lower Volume	Lower Volume. Adjusts the volume level of the left (Lower) side of a split keyboard.	0 to 127
Split Point	Split Point. Specifies the left/right keyboard split point. The initial default split point is F#3.	A0 to C8
Lower Pedal	Lower Pedal. Enables (On) or disables (Off) damper pedal operation for the tone of the left (Lower) side of a split keyboard.	On (Enabled), Off (Disabled)

3. Use the **21** **<** (-) and **>** (+) arrow buttons to change the setting.
4. To return to the screen you were at prior to step 1 of this procedure, press **20** **EXIT** button.

Using the Metronome

The metronome lets you play and practice along with a steady beat to help keep you on tempo.

To start and stop

- Press **8** METRONOME button.
 - This starts the metronome.
 - This causes the button lamp to light.
 - This will cause the **15** ▶/|| button lamps to flash in time with the currently set tempo. The **15** ▶/|| button left lamp flashes on the first beat of each measure, while the right lamp flashes on the remaining beats of the measure.

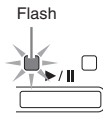

- Press **8** METRONOME button again to stop the metronome.
 - This will cause the **8** METRONOME button and **15** ▶/|| button lamps to become unlit.

To adjust the tempo

- Use the **9** TEMPO ▼ (–) and ▲ (+) buttons to set the tempo you want.
 - Press the **9** ▼ and ▲ arrow buttons at the same time to set the tempo of last selected Concert Play / Music Library song. If a recording function is being used, this operation sets a tempo of 120.
 - The setting range is 20 to 255.

METRONOME	
# Tempo	120
• Beat	4
• Volume	100

NOTE

- Changing the metronome speed (tempo) also changes the playback tempo of Music Library songs and MIDI Recorder songs.

To configure metronome settings

- Hold down the **8** METRONOME button until the screen shown below appears.

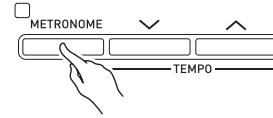

METRONOME	
# Tempo	120
• Beat	4
• Volume	100

- Use the **21** ▼ and ▲ arrow buttons to one of the items below.

Display Name	Description	Setting Range
Beat	Beat. Specifies the beat setting. The first beat of each measure is a bell sound, while the remaining beats are clicks. <ul style="list-style-type: none"> A Beat setting of "0" plays a straight click, without a bell sound. 	0 to 9
Volume	Volume. Adjusts the metronome volume.	0 to 127

- Use the **21** < (–) and > (+) arrow buttons to change the setting.
- Press the **20** EXIT button to exit the setting screen.

Changing Keyboard Response to Touch Pressure (Touch Response)

Touch Response alters tone volume in accordance with keyboard pressure (speed). This provides you some of the same expressivity you get on an acoustic piano.



Pressing fast produces louder notes.

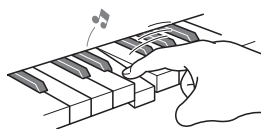

Pressing slowly produces softer notes.

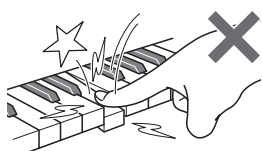

Do not try to use too much pressure.

To change touch response sensitivity

Use the procedure below to control how much the volume of played notes change in accordance with playing speed. Select the setting that best matches your playing style.

1. Press the **3**SETTING button to display the setting screen.
2. Use the **21**∨ and ∧ arrow buttons to select “Keyboard” and then press the **22**ENTER button.

● Keyboard >Ent

3. Use the **21**∨ and ∧ arrow buttons to select “Touch Response”.

● Touch Response

4. Use the **21**< and > arrow buttons to select one of the settings below for touch response.

Disabled (Off)	Touch Response disabled. Sound volume is fixed, regardless of key press speed.
Light (Light)	More sensitive Touch Response than Normal.
Normal (Normal)	Normal Touch Response.
Heavy (Heavy)	This setting makes it easier to output smaller sound than Normal.

5. Press the **3**SETTING button to exit the setting screen.

Changing the Pitch (Transpose, Tuning, Octave Shift)

To change the pitch in semitone steps (Transpose)

The transpose feature lets you change the pitch, in semitone steps. A simple operation lets you instantly change the pitch to match that of a singer.

- The transpose setting range is -12 to +12 semitones.

1. Press the **3**SETTING button to display the setting screen.
2. Use the **21**∨ and ∧ arrow buttons to select “Keyboard” and then press the **22**ENTER button.
3. Use the **21**∨ and ∧ arrow buttons to select “Transpose”.

● Transpose

4. Use the **21**< (-) and > (+) arrow buttons to set the transpose key.
5. Press the **3**SETTING button to exit the setting screen.

Fine Tuning (Tuning)

Use the tuning feature when you need to adjust the pitch slightly to play along with another musical instrument. Also, some artists perform their music with slightly altered tuning. You can use the tuning feature to adjust tuning so it exactly matches a performance on a CD.

- The tuning feature specifies the frequency of the A4 note. You can set a frequency within the range of 415.5 to 465.9 Hz. The initial default setting is 440.0 Hz.
- Some CD performances are recorded with instruments that are tuned slightly different from standard.

1. Press the **3** **SETTING** button to display the setting screen.
2. Use the **21** **▼** and **▲** arrow buttons to select “Keyboard” and then press the **22** **ENTER** button.
3. Use the **21** **▼** and **▲** arrow buttons to select “Tuning”.

● *Tuning*

4. Use the **21** **<** (-) and **>** (+) arrow buttons to fine adjust the tuning.
 - The setting can be adjusted in units of 0.1 Hz.
5. Press the **3** **SETTING** button to exit the setting screen.

To change the tuning curve (Stretch Tuning)

Generally, a piano is tuned so high notes are sharper and low notes are flatter. This type of tuning is called “stretch tuning”.

Your Digital Piano lets you change how its stretch tuning is applied. You can also disable Stretch Tuning, if you want.

1. Press the **3** **SETTING** button to display the setting screen.
2. Use the **21** **▼** and **▲** arrow buttons to select “Keyboard” and then press the **22** **ENTER** button.
3. Use the **21** **▼** and **▲** arrow buttons to select “Stretch Tune”.

● *Stretch Tune*

4. Use the **21** **<** and **>** arrow buttons to select one of the stretch tunings described below.

Display Name	Description
Default	Initial factory default setting (Default). Use of this setting is recommended because it applies the optimum stretch tuning for the currently selected tone.
Upper1	Applies the optimum stretch tuning for the tone that is currently selected for Upper 1 (Upper1). Upper 1 stretch tuning is also applied to the Upper 2 and Lower tones. Use of this setting is recommended when you want to minimize differences in the pitch between keyboard layer and split tones.
Off	Disabled (Off). Disables Stretch Tuning.
Piano1	BERLIN GRAND stretch tuning. Applies initial factory default BERLIN GRAND stretch tuning to other tones as well.
Piano2	HAMBURG GRAND stretch tuning.
Piano3	VIENNA GRAND stretch tuning.
E.Piano1	Electric Piano 1 (E.Piano1) stretch tuning.
E.Piano2	Electric Piano 2 (E.Piano2) stretch tuning.

5. Press the **3** **SETTING** button to exit the setting screen.

Octave Shift

Octave Shift lets you raise or lower the pitch of the keyboard notes in octave units.

- The octave shift setting range is -2 to +2 octaves.

NOTE

- For information about changing the split function octave, see “To modify split settings” on page EN-18.

1. Press the **3**SETTING button to display the setting screen.
2. Use the **21**▼ and ▲ arrow buttons to select “Keyboard” and then press the **22**ENTER button.
3. Use the **21**▼ and ▲ arrow buttons to select “Octave Shift”.

● Octave Shift

4. Use the **21**< (-) and > (+) arrow buttons to change the octave.
5. Press the **3**SETTING button to exit the setting screen.

Changing the Temperament of the Keyboard

You can use the following procedure to select from among 17 preset temperaments, including the standard Equal Temperament.

No.	Temperament name	Display
00	Equal Temperament	Equal
01	Pure Major	Pure Major
02	Pure Minor	Pure Minor
03	Pythagorean	Pythagorean
04	Kirnberger 3	Kirnberger 3
05	Werckmeister	Werckmeister
06	Mean-Tone	Mean-Tone
07	Rast	Rast
08	Bayati	Bayati
09	Hijaz	Hijaz
10	Saba	Saba
11	Dashti	Dashti
12	Chahargah	Chahargah
13	Segah	Segah
14	Gurjari Todi	Gurjari Todi
15	Chandrakauns	Chandrakauns
16	Charukeshi	Charukeshi

1. Press the **3**SETTING button to display the setting screen.
2. Use the **21**▼ and ▲ arrow buttons to select “Keyboard” and then press the **22**ENTER button.
3. Use the **21**▼ and ▲ arrow buttons to select “Temper. Type”.

● Temper. Type

4. Use the **21**< and > arrow buttons to select a temperament name.
5. Press the **21**▼ arrow button to select “Temper. Base Note”.
6. Use the **21**< and > arrow buttons to select the root key of the selected temperament.
7. Press the **3**SETTING button to exit the setting screen.

Using Built-in Songs (Concert Play, Music Library)

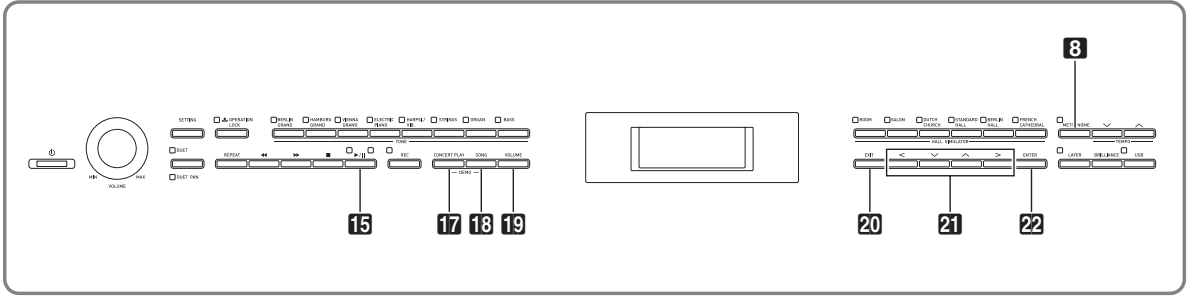

Your Digital Piano comes with 15 built-in piano and orchestra tunes (Concert Play 1 through 15), and 60 piano solos (Music Library 1 to 60). Concert Play lets you enjoy playing along with orchestral accompaniment. You can use Music Library to practice famous piano pieces.

IMPORTANT!

- After you select a built-in song, it can take a number of seconds for the song data to be loaded. While the data is being loaded, the keyboard keys and button operations will be disabled. If you are playing something on the keyboard, the following operation will cause output to stop.

- Use of the Digital Piano's metronome is not supported during Concert Play.
- The Concert Play contains actual recordings of an orchestra. Because of this, the instrument sounds are different from the tones that can be selected with this piano (page EN-10).
- Due to conditions when a live recording was made, playback may include the sound of the performer's breathing, performance noise, or other noise.

To listen to a Concert Play Song (Listen Mode)

1. Press the **17** CONCERT PLAY button.

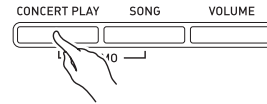

Concert Play

Concert Play has recordings of a live orchestra, which you can use to play along with authentic accompaniment.

Step 1: LISTEN

Listen to playback of the piano and orchestra to familiarize yourself with the music.

Step 2: PLAY

Play along with the orchestra accompaniment.

NOTE

- The Concert Play includes 15 songs, numbered 1 through 15.
- A song on a USB flash drive (Concert Play song data obtained with a computer, etc.) plugged into the Digital Piano's USB port can be used as Concert Play song.
- You can play back at a slow tempo (80% of the original).

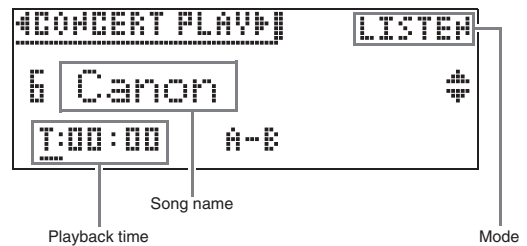

2. Use the **21** \downarrow and \uparrow arrow buttons to select a song and then press the **22** ENTER button.
 - For a list of songs, see the "Concert Play List" (page A-2).
 - You can use the **21** \leftarrow and \rightarrow arrow buttons to scroll through the song list pages.
3. Use the **17** CONCERT PLAY button to enter the Listen Mode ("LISTEN").
 - Each press of the CONCERT PLAY button toggles between modes as shown below.

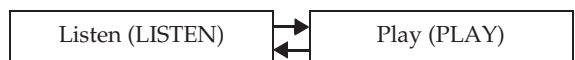

- If you want to play back at a slower tempo (80%), press the **3** METRONOME button so “SLOW” is displayed.



- To return to the original tempo, press the **3** METRONOME button again to clear “SLOW” from the display.

- Press the **15** ▶/|| button to start playback.

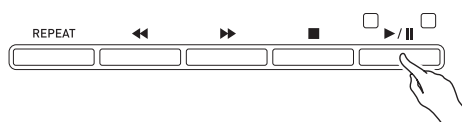

- For details about playback, see “Starting and Stopping Playback” in “Operations Common to All Modes” (page EN-8).
- For details about how to return to the home screen, see “About the Home Screen” (page EN-8).

NOTE

- You can adjust playback volume as required. For details to adjust the volume level, see “To adjust the playback volume level of a Concert Play song” on page EN-25.

To play along with an orchestra using Concert Play (Play Mode)

- Perform steps 1 and 2 of the procedure under “To listen to a Concert Play Song (Listen Mode)” (page EN-23) to select a song.
- Use the **17** CONCERT PLAY button to enter the Play Mode.

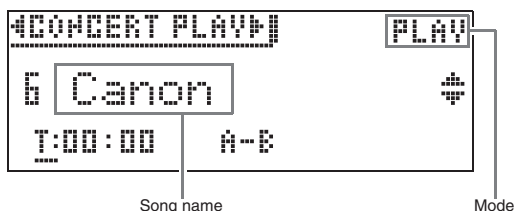

- If you want to play back at a slower tempo (80%), press the **3** METRONOME button so “SLOW” is displayed.
 - To return to the original tempo, press the **3** METRONOME button again to clear “SLOW” from the display.
- Press the **15** ▶/|| button to start playback.
 - For details about playback, see “Starting and Stopping Playback” in “Operations Common to All Modes” (page EN-8).
 - With some songs, the play-along part (the part you will play on the Digital Piano) may be slightly audible during Play Mode playback.
- Play the play-along part on the Digital Piano.
 - For details about how to return to the home screen, see “About the Home Screen” (page EN-8).

To adjust the playback volume level of a Concert Play song

1. Press the **[19] VOLUME** button.

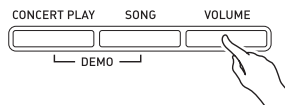

2. Use the **[21] <** (-) and **>** (+) arrow buttons to adjust the volume.
 - The setting range is 0 to 127.
3. Press the **[20] EXIT** button to exit the setting screen.

Concert Play Songs Obtained with a Computer, etc.

You can use a USB flash drive to play back Concert Play songs obtained with a computer, etc. on the Digital Piano.

- For details, visit the website below.
<http://world.casio.com/>

To save Concert Play songs obtained with a computer, etc. to a USB flash drive

PREPARATION

- To use a USB flash drive, you first need to format it on the Digital Piano. See "Preparing a USB Flash Drive" on page EN-45 for more information.

1. Connect the USB flash drive to your computer.
2. Copy the Concert Play files (both the .LSN and .PLY files) from your computer to the CP folder on the USB flash drive.

To play back Concert Play songs obtained with a computer, etc.

1. Insert the USB flash drive into the Digital Piano's USB flash drive port.
2. Press the **[17] CONCERT PLAY** button.
3. Press the **[21] >** arrow button. This will cause "USB" to appear in the upper right corner of the screen.



- The message "No Media" will appear on the display if there is no USB flash drive plugged into the Digital Piano.
 - To return to the Digital Piano memory contents, press the **[21] <** arrow button.
4. Use the **[21] v** and **^** arrow buttons to select a song and then press the **[22] ENTER** button.
 - To find out what you need to do next, see the pages below.
 - From step 3 under "To listen to a Concert Play Song (Listen Mode)", page EN-23
 - From step 2 under "To play along with an orchestra using Concert Play (Play Mode)", page EN-24
 - For details about how to return to the home screen, see "About the Home Screen" (page EN-8).

Music Library

You can use the Music Library for your listening enjoyment or to practice piano songs.

- The Music Library includes 60 songs, numbered 1 through 60.
- You can also import up to 10 songs (page EN-50 "Loading USB Flash Drive Data into Digital Piano Memory") from a USB flash drive to Digital Piano memory, and assign them Music Library song numbers 61 through 70. Any song number that already contains imported data will be indicated by an asterisk (*) between the song name and number.

To play back a specific music library song

1. Press the **18** SONG button.

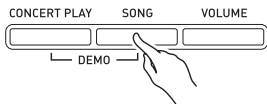

2. Use the **21** < and > arrow buttons to select "MUSIC LIB".

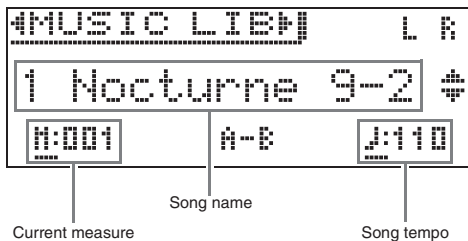

3. Use the **21** v and ^ arrow buttons to select a song and then press the **22** ENTER button.

- For a list of songs, see the "Music Library List" (page A-3).
- You can use the **21** < and > arrow buttons to scroll through the song list pages.

4. Press the **15** ▶/|| button to start playback.

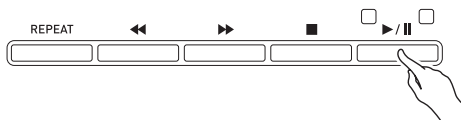

- For details about playback, see "Starting and Stopping Playback" in "Operations Common to All Modes" (page EN-8).
- For details about how to return to the home screen, see "About the Home Screen" (page EN-8).

NOTE

- The settings below can be configured for playback.
 - Song volume level: To adjust the playback volume level of a MIDI Recorder song (page EN-34)
 - Tempo: To adjust the tempo (page EN-19)

To practice with a music library song

You can turn off the left hand part or right hand part of a song and play along on the Digital Piano.

NOTE

- The Music Library includes a number of duets. While a duet is selected, you can turn off the first piano (Primo) or second piano (Secondo) tone and play along with the song.

PREPARATION

- Select the song you want to practice and adjust the tempo. See "To adjust the tempo" (page EN-19).
- A number of tunes have tempo changes part way through in order to produce specific musical effects.

1. Use the **18** SONG button to select the part you want to play back (the sound you don't want to mute).

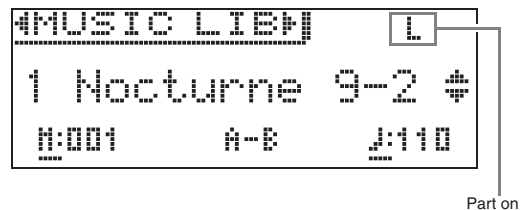

- Each press of **18** SONG button cycles through the settings shown below.
 - L: Plays the left-hand part and mutes the right-hand part.
 - R: Plays the right-hand part and mutes the left-hand part.
 - L R: Plays both the left-hand and right-hand parts.

2. Press the **15** ▶/|| button to start playback.

- For details about playback, see "Starting and Stopping Playback" in "Operations Common to All Modes" (page EN-8).

3. Play the missing part on the keyboard.

- For details about how to return to the home screen, see "About the Home Screen" (page EN-8).

Playing Back Song Data Stored on a USB Flash Drive

You can use your Digital Piano to play back audio files*1 and MIDI files*2 stored on a commercially available USB flash drive.

See “USB Flash Drive” on page EN-44 for more information.

*1 WAV format (Linear PCM, 16bit, 44.1 kHz, Stereo)

*2 Standard MIDI files (SMF format 0/1), MIDI Recorder song files (CSR format), CASIO MIDI files (CM2 format)

PREPARATION

- Prepare a USB flash drive that contains data recorded to it using the Digital Piano’s Audio Recorder. See “Audio Recorder (Recording to a USB Flash Drive)” on page EN-35 for more information. You can also use a computer to save song data to the USB Flash Drive for playback. See “Saving Standard Song Data to a USB Flash Drive” on page EN-48 for more information.
- Insert the USB flash drive that contains the data you want to play back into your Digital Piano’s USB flash drive port.
- Never remove the USB flash drive while song data stored on it is being accessed by the Digital Piano. Doing so can corrupt the data on the USB flash drive and damage the USB flash drive port.

1. Press the **18** SONG button.
2. Use the **21** < and > buttons to select the song data type you want.
 - MIDI file: SMF
 - Audio file: AUDIO PLAY
3. Use the **21** ∨ and ∧ arrow buttons to select a song and then press the **22** ENTER button.
 - You can use the **21** < and > arrow buttons to scroll through the song list pages.
4. Press the **15** ▶/|| button to start playback.
 - For details about playback, see “Starting and Stopping Playback” in “Operations Common to All Modes” (page EN-8).
 - For details about how to return to the home screen, see “About the Home Screen” (page EN-8).

To adjust the playback volume level of song data

1. Press the **19** VOLUME button.

SONG	1/2
• MIDI Volume	0127
• Audio Volume	0127
• ML Clear	>Ent

2. Use the **21** ∨ and ∧ buttons to select the song data type you want.
 - MIDI file: MIDI Volume
 - Audio file: Audio Volume
3. Use the **21** < (–) and > (+) arrow buttons to adjust the volume.
 - The setting range is 0 to 127.
4. Press the **20** EXIT button to exit the setting screen.

Demo Song

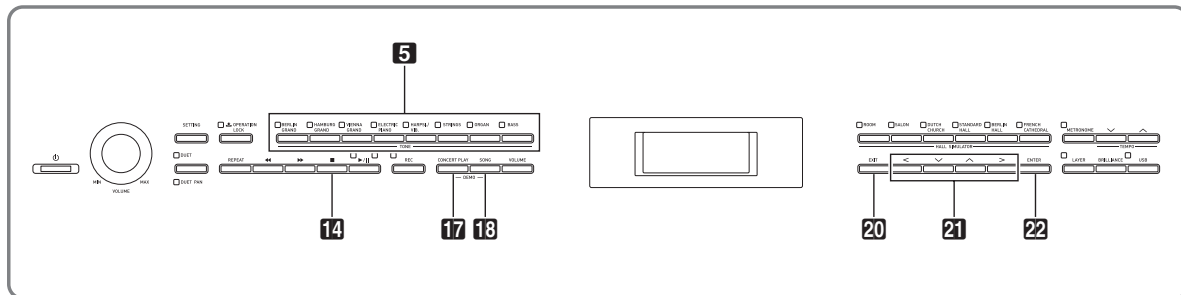

All of the Digital Piano's built-in songs can be played back for your listening enjoyment.

Grand Piano demo songs: 6

Concert Play songs: 15

Music Library songs: 60

IMPORTANT!

- After you select a built-in song, it can take a number of seconds for the song data to be loaded. While the data is being loaded, the keyboard keys and button operations will be disabled. If you are playing something on the keyboard, the following operation will cause output to stop.

Performing Demo Play

1. Press the **17** CONCERT PLAY button and **18** SONG button at the same time.

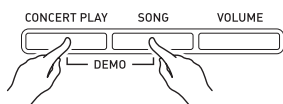

- This starts playback from Grand Piano demo song 1.
- While a song is playing, the **14** button lamps flash.
- You can play along with a demo songs on the keyboard.

2. To change to another song, use the **21** \checkmark and \wedge arrow buttons to select a song name and then press the **22** ENTER button.

- This starts demo play.
- You can use the **21** \leftarrow and \rightarrow arrow keys to scroll through song groups in the following sequence: Grand Piano demo songs \rightarrow Concert Play songs \rightarrow Music Library songs. Selecting a different song group causes song 1 of the group to be selected.
- For information about the songs in each group, see the song lists on page A-2.
- You can also switch to a Grand Piano group song while demo play is in progress. Press one of the following buttons to select the grand piano tone you want: **5** BERLIN GRAND, HAMBURG GRAND, VIENNA GRAND.

3. To stop demo play, press the **14** button or the **20** EXIT button.

NOTE

- The tune selection and playback stop operations described above are the only operations that are possible during demo song play.

Comparing Grand Piano Tones

A simple operation lets you play demo songs that highlight the particular characteristics of each of the following grand piano tones so you can hear the difference between them: BERLIN GRAND, HAMBURG GRAND, VIENNA GRAND.

1. Hold down the button of the tone whose demo song you want to hear (**5** **BERLIN GRAND**, **HAMBURG GRAND**, or **VIENNA GRAND**) until the first demo tune assigned to the tone starts to play.
 - There is a total of six grand piano demo songs, two for each of the grand piano tones (BERLIN GRAND, HAMBURG GRAND, and VIENNA GRAND). When you start playback, the two songs are played in a loop, one after the other. For a list of songs, see the “Grand Piano Demo Song List” (page A-3).
 - To change to a different demo song or to stop demo song play, perform steps 2 through 3 under “Performing Demo Play” (page EN-28).

Recording and Playback

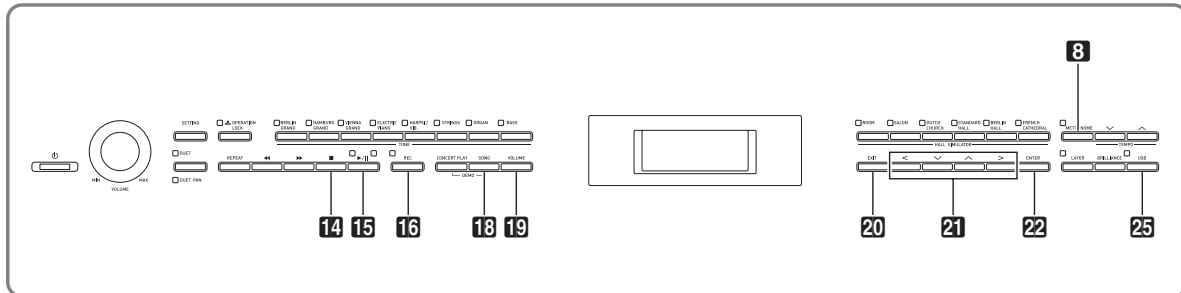

Your Digital Piano can record what you play on the keyboard and play it back when you want. The Digital Piano has two recording functions: a MIDI Recorder and an Audio Recorder. Select the function that suits the needs for the type of recording you want to make.

IMPORTANT!

- CASIO COMPUTER CO., LTD. takes no responsibility for any damages, lost profits, or claims by third parties arising from the deletion of recorded data due to malfunction, repair, or for any other reason.

Recording Features

MIDI Recorder	Audio Recorder
<p>Keyboard performance information is recorded to Digital Piano memory as MIDI data* to two tracks (storage areas for keyboard performance data).</p>	<p>Keyboard performance information is recorded to a USB flash drive as audio data.</p>
<ul style="list-style-type: none"> Keyboard performance information (keyboard keys press/release, touch pressure, etc.) is recorded as MIDI data. The size of MIDI data is much smaller when compared with audio data, making it easier to edit later on a computer, etc. Supported recording capacity: Up to 5,000 notes (total of tracks 1 and 2), one file only 	<ul style="list-style-type: none"> Like a portable music player or tape recorder, notes are recorded as audio data. Audio data files are much larger compared to MIDI data files. The advantage of audio data files is that they can be easily played back on a computer, portable music player, etc. Supported recording capacity: Up to 99 files, each file up to a maximum length of 25 minutes
<p>What you can do... Record to one track while playing back from the other track</p> <pre> graph LR subgraph Track1 [Track 1] K1[Keyboard play] end subgraph Track2 [Track 2] K2[Keyboard play] end subgraph Playback [While playing back...] P[While playing back...] end K1 --> P K2 --> P </pre>	<p>What you can do... Record performance while playing back a song recorded with the MIDI Recorder</p> <pre> graph LR subgraph Input [MIDI Recorder song playback] M[MIDI Recorder song playback] end subgraph Action [Keyboard play] K[Keyboard play] end subgraph Output [Record] R[Record] end M --> R K --> R </pre>

■ Playback Features

MIDI Recorder	Audio Recorder									
<p>Plays back Track 1 and Track 2 (simultaneously or individually).</p> <ul style="list-style-type: none"> With the MIDI Recorder, the Digital Piano automatically performs playback using its internal sound source in accordance with the performance information recorded as MIDI data. <div style="border: 1px solid black; padding: 5px;"> <p>What you can do...</p> <p>Play on the keyboard along with playback of Tracks 1 and 2</p> <table style="width: 100%; border-collapse: collapse;"> <tr> <td style="padding: 2px;">Track 1 →</td> <td style="border: 1px solid black; padding: 2px; text-align: center;">While playing back...</td> </tr> <tr> <td style="padding: 2px;">Track 2 →</td> <td style="border: 1px solid black; padding: 2px; text-align: center;">While playing back...</td> </tr> <tr> <td></td> <td style="border: 1px solid black; padding: 2px; text-align: center;">Keyboard play</td> </tr> </table> <p>After recording, change the tempo of Track 1 For example, you can record at a slow tempo and then play back at a faster tempo.</p> <ul style="list-style-type: none"> The tempo set for Track 1 is applied to Track 2. </div>	Track 1 →	While playing back...	Track 2 →	While playing back...		Keyboard play	<p>You can play back audio data from a USB flash drive.</p> <ul style="list-style-type: none"> The Audio Recorder plays back the waveform of sound recorded as audio data. <div style="border: 1px solid black; padding: 5px;"> <p>What you can do...</p> <p>Play along on the keyboard while the audio data is playing</p> <table style="width: 100%; border-collapse: collapse;"> <tr> <td style="border: 1px solid black; padding: 5px; text-align: center;">Playback of a song on a USB flash drive</td> <td style="text-align: center; vertical-align: middle;">+</td> <td style="border: 1px solid black; padding: 5px; text-align: center;">Keyboard play</td> </tr> </table> </div>	Playback of a song on a USB flash drive	+	Keyboard play
Track 1 →	While playing back...									
Track 2 →	While playing back...									
	Keyboard play									
Playback of a song on a USB flash drive	+	Keyboard play								

* MIDI

MIDI is short for “Musical Instrument Digital Interface”. It is a universal standard that makes it possible for musical instruments, computers, and other devices to exchange performance information (keyboard key press/release, touch pressure, etc.) regardless of manufacturer. Performance data in this case is called “MIDI data”.

- For details about the file formats of data supported by this Digital Piano, see “Data Types Supported by the Digital Piano” (page EN-46).

MIDI Recorder (Recording to Digital Piano Memory)

After recording to either of the tracks of a song, you can record to the other track while listening to playback what you recorded in the first track.

- The items below are reflected in contents when recording to the tracks.
 - Keyboard play and pedal operations
 - Tone setting
 - Tempo setting
 - Beat setting
 - Layer setting (Track 1 only)
 - Split setting (Track 1 only)
 - Duet Mode (Track 1 only)
 - Effects (Track 1 only)
 - Acoustic Simulator (Track 1 only)
 - Temperament setting (Track 1 only)
 - Stretch Tuning setting (Track 1 only)
- Recording stops automatically if the number of notes in memory exceeds the maximum.
- Starting a new recording deletes any data that was previously recorded in memory.
- Should power fail during recording, all of the data in the track you are recording will be deleted.

To record to a specific song track

NOTE

- You can configure the Digital Piano to sound a count before the start of recording (Precount). For details about how to configure precount settings, see “To configure precount settings” (page EN-33).

PREPARATION

- Select the tone and effects (Track 1 only) you want to use in your recording.
 - Tone (page EN-10)
 - Effects (page EN-13)
- If you want the metronome to sound while you are recording, configure the beat and tempo settings, and then press the **8** METRONOME button. See “Using the Metronome” on page EN-19 for more information.

1. Press the **16** REC button.

- “Rec Wait...” appears on the display indicating record standby.

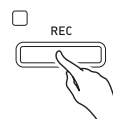

2. Use the **21** < and > arrow buttons to select “MIDI REC”.

MIDI REC

3. Use the **16** REC button to select a track for recording.

- L: Track 1
- R: Track 2



4. Press the **15** ▶/|| button to start recording.

- You can also start recording by simply playing something on the keyboard.

5. To stop recording, press the **14** ■ button.

- This displays “Rec Song” to indicate that the recorded song is in playback standby.
- To play back the track you just recorded, press the **15** ▶/|| button.

To record the other track of a song

You can listen to playback of the track you recorded as you record to the other track.

PREPARATION

- Select the tone and effects (Track 1 only) you want to use in your recording.
Tone (page EN-10)
Effects (page EN-13)
- If you want the metronome to sound while you are recording, configure the beat and tempo settings, and then press the **8** METRONOME button. See “Using the Metronome” on page EN-19 for more information.

1. Hold down the **16** REC button until the setting screen shown below appears.

RECORDER	1/2
• Recorded Part	[Play]
• Part Clear	>Ent
• Precount	[On]

2. Use the **21** \vee and \wedge arrow buttons to select “Recorded Part”.

• Recorded Part

3. Use the **21** \leftarrow and \rightarrow arrow buttons to enable (Play) or disable (Mute) of the recorded track.
4. Press the **16** REC button.
 - “Rec Wait...” appears on the display indicating record standby.
5. Use the **21** \leftarrow and \rightarrow arrow buttons to select “MIDI REC”.

6. Use the **16** REC button to select a track for recording.
 - L: Track 1
R: Track 2
 - “L” and “R” indicate status information about the left and right tracks as described below.
 - If you selected “Play” in step 3, above:
Flashing: Track to be recorded.
Lit: Track to be played back.
 - If you selected “Mute” in step 3, above:
Flashing: Track to be recorded.
Unlit: Track to be muted.

MIDI REC	L R
• Rec Wait..	
0:00	

7. Press the **15** \blacktriangleright /|| button or play something on the keyboard.
 - This will start both playback of the recorded track and recording to the other track.
8. To stop recording, press the **14** ■ button.

To configure precount settings

1. Hold down the **16** REC button until the setting screen shown below appears.

RECORDER	1/2
• Recorded Part	[Play]
• Part Clear	>Ent
• Precount	[On]

2. Use the **21** \vee and \wedge arrow buttons to select “Precount”.
3. Use the **21** \leftarrow and \rightarrow arrow buttons to enable (On) or disable (Off) the precount.
4. Press the **20** EXIT button to exit the setting screen.

To play back from Digital Piano memory

1. Press the **18** SONG button.

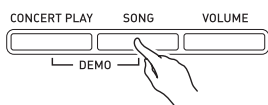

2. Use the **21** < and > arrow buttons to select "MIDI PLAY".

MIDI PLAY

3. Use the **18** SONG button to select the track you want to play back.

- Each press of **18** SONG button cycles through the settings shown below.

L: Track 1

R: Track 2

L R: Track 1 and Track 2

4. Press the **15** ▶/|| button to start playback.

- For details about playback, see "Starting and Stopping Playback" in "Operations Common to All Modes" (page EN-8).

NOTE

- You can change tempo, effect, and other settings during playback.

To adjust the playback volume level of a MIDI Recorder song

1. Press the **19** VOLUME button.

SONG	1/2
• MIDI Volume	[127]
• Audio Volume	[127]
• ML Clear	>Ent

2. Use the **21** < (-) and > (+) arrow buttons to adjust the volume.

- The setting range is 0 to 127.

3. Press the **20** EXIT button to exit the setting screen.

To delete recorded data

The following procedure deletes a specific track of a song.

IMPORTANT!

- The procedure below deletes all of the data of the selected track. Note that the delete operation cannot be undone. Check to make sure you really do not need the data in Digital Piano memory before you perform the following steps.

1. Hold down the **16** REC button until the setting screen shown below appears.

RECORDER	1/2
• Recorded Part	[Play]
• Part Clear	>Ent
• Precount	[On]

2. Use the **21** ∨ and ∧ arrow buttons to select "Part Clear" and then press the **22** ENTER button.

• Part Clear

3. Use the **21** < and > arrow buttons to select the track to which you want to delete and then press the **22** ENTER button.

- L: Track 1
- R: Track 2

- This will cause the confirmation message "Sure?" to appear.

4. Press the **21** > arrow button to execute the delete operation.



- To cancel the delete operation, press the **21** < arrow button.
- The message “Please Wait...” will remain on the display while the operation is being performed. Do not perform any operation while this message is on the display. “Complete!” appears on the display after the operation is complete.

Audio Recorder (Recording to a USB Flash Drive)

Anything played on the Digital Piano is recorded to the USB flash drive as audio data (WAV files*). If you play along on the Digital Piano as you play back data stored in Digital Piano memory, the memory playback and your keyboard play are both recorded to USB flash drive.

* Linear PCM, 16bit, 44.1 kHz, Stereo

- Each new recording of audio data to a USB flash drive is automatically assigned a new file name, so existing data is not overwritten.
- Concert Play song playback tones cannot be recorded to a USB flash drive by Audio Recorder.
- Never remove the USB flash drive while Audio Recorder recording or playback is in progress. Doing so can corrupt the data on the USB flash drive and damage the USB flash drive port.

To record keyboard play to a USB flash drive

PREPARATION

- Be sure to format the USB flash drive on the Digital Piano before using it. See “USB Flash Drive” on page EN-44 for more information.

1. Insert the USB flash drive into the Digital Piano's USB flash drive port.

- When you plug in a USB flash drive, the Digital Piano initially needs to “mount” the USB flash drive and prepare for data exchange. Note that Digital Piano operations are momentarily disabled while a USB flash drive mounting sequence is being performed, which is indicated by the **25** USB button lamp flashing. The lamp will stop flashing and remain lit after mounting is complete. It may take up to 10 or 20 seconds or even longer for a USB flash drive to be mounted. Do not attempt to perform any operation on the Digital Piano while a mounting sequence is in progress. A USB flash drive needs to be mounted each time it is connected to the Digital Piano.

2. Press the **16** REC button.

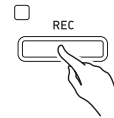

- “Rec Wait...” appears on the display indicating record standby.



3. Use the **21** < and > arrow buttons to select “AUDIO REC”.

4. Press the **15** ▶/|| button to start recording.

- You can also start recording by simply playing something on the keyboard.

5. To stop recording, press the **14** ■ button.

- Data recorded with Audio Recorder is stored as WAV files on the USB flash drive. Files are automatically assigned names in sequence from “TAKE01.WAV” through “TAKE99.WAV”.
- If you want to continue recording, perform the operations from step 2 of this procedure. To play back something immediately after you record it, press the **15** ▶/|| button.

To record keyboard play while playing back a MIDI Recorder song or song data

- For song data, you can play back the last Music Library you played back.

1. Hold down the **16**REC button until the setting screen shown below appears.

RECORDER	1/2
# Recorded Part	[Play]
* Part Clear	>Ent
* Precount	[On]

2. Use the **21**∨ and ∧ arrow buttons to select “Audio Rec with MIDI”.

● Audio Rec with MIDI

3. Use the **21**< and > arrow buttons to select the type of song you want to play.

- MIDI PLAY: MIDI Recorder
- MUSIC LIB: Music Library
- If you do not want to play anything, select “Off”.

4. Press the **16**REC button.

- “Rec Wait...” appears on the display indicating record standby.

5. Use the **21**< and > arrow buttons to select “AUDIO REC”.

AUDIO REC

6. Press the **15**▶/|| button.

- This starts playback and recording. Play along on the keyboard.

7. To stop recording, press the **14**■ button.

- If you want to continue recording, perform the operations from step 4 under “To record keyboard play to a USB flash drive” (page EN-35). To play back something immediately after you record it, press the **15**▶/|| button.

To play back data recorded on a USB flash drive

- Use the steps below to play back the last song you recorded.
- For information about selecting a file for playback see “Playing Back Song Data Stored on a USB Flash Drive” (page EN-27).
- The playback tempo of an audio file cannot be changed.

1. Press the **18**SONG button.

2. Use the **21**< and > arrow buttons to select “AUDIO PLAY”.

3. Press the **15**▶/|| button to start playback.

- For details about playback, see “Starting and Stopping Playback” in “Operations Common to All Modes” (page EN-8).

To adjust the Audio Recorder volume level

1. Press the **19**VOLUME button.

SONG	1/2
* MIDI Volume	[127]
# Audio Volume	[127]
* ML Clear	>Ent

2. Use the **21**∨ and ∧ arrow buttons to select “Audio Volume”.

3. Use the **21**< (-) and > (+) arrow buttons to adjust the volume.

- The setting range is 0 to 127.

4. Press the **20**EXIT button to exit the setting screen.

To delete the currently selected Audio Recorder song data

! IMPORTANT!

- The procedure below deletes all of the data of the selected file. Note that the delete operation cannot be undone. Check to make sure you really do not need the data in Digital Piano memory before you perform the following steps.

1. Hold down the **18** SONG button until the setting screen shown below appears.

SONG	1/2
* MIDI Volume	0120
* Audio Volume	0120
* ML Clear	>Ent

2. Use the **21** \vee and \wedge arrow buttons to select "Audio Delete" and then press the **22** ENTER button.
3. Press the **21** \triangleright arrow button to execute the delete operation.
 - To cancel the delete operation, press the **21** \triangleleft arrow button.
 - The message "Please Wait..." will remain on the display while the operation is being performed. Do not perform any operation while this message is on the display. "Complete!" appears on the display after the operation is complete.

Configuring Digital Piano Settings

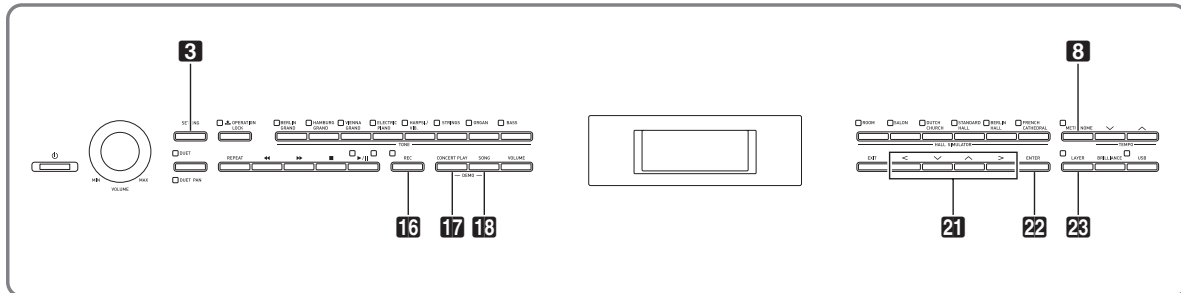

The setting screens explained in this section can also be displayed using the **3** **SETTING** button. This section explains how to display settings and parameter list.

Configuring Settings

1. Press the **3** **SETTING** button to display the setting screen.

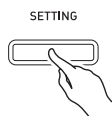

- This displays a list of parameters.

SETTING	1/4
# Duet	>Ent
# Acoustic Simulator	>Ent
# Effect	>Ent

2. Use the **21** ∇ and \blacktriangle arrow buttons to select a parameter.

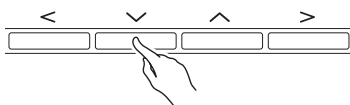

- For details about parameters, see the “Parameter List” (page EN-39). The shaded cells in the parameter list are top menu items.
- “>Ent” to the right of an item indicates that pressing the **22** **ENTER** button while that item is selected will display a submenu of parameters.

3. Use the **21** \leftarrow and \rightarrow arrow buttons to change the currently selected value or setting.

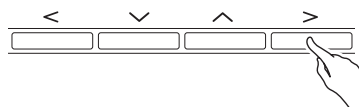

- For details about setting procedures, see “Changing a Number or a Value” in “Operations Common to All Modes” (page EN-8).

4. After a parameter setting is the way you want, press the **3** **SETTING** button to exit the setting screen.

Parameter List

Display Text	Description	Settings	Go here for more information
Duet >Ent	Duet Mode parameters.		
Duet Mode	Duet Mode setting • The Hall Simulator and chorus cannot be applied while in the Duet Pan Mode.	(See the page to the right.)	Splitting the Keyboard for Duet Play (page EN-14)
Upper Octave	Octave of the right keyboard		To change the octaves of the duet keyboards (page EN-15)
Lower Octave	Octave of the left keyboard		
Acoustic Simulator >Ent	Acoustic Simulator parameters		
Hammer Response	Hammer Response	(See the page to the right.)	Adjusting Acoustic Piano Sound Characteristics (page EN-12)
Lid Simulator	Lid Simulator		
Damper Resonance	Damper Resonance		
Damper Noise	Damper Noise		
String Resonance	String Resonance		
Effect >Ent	Tone effect parameters		
Hall Simulator	Hall Simulator • You can disable Hall Simulator by selecting "OFF" (Disabled) for this setting.	(See the page to the right.)	To apply a hall simulator (page EN-13)
Position	Instrument sound listening position		To select a listening position (page EN-13)
Chorus	Chorus		To apply chorus to a tone (page EN-14)
Brilliance	Brilliance		To adjust brilliance (page EN-14)

Display Text	Description	Settings	Go here for more information
Keyboard >Ent	Keyboard parameters		
Touch Response	Touch Response	(See the page to the right.)	Changing Keyboard Response to Touch Pressure (Touch Response) (page EN-20)
Transpose	Changes the pitch of notes in semitone units. • Raising the key of the Digital Piano can cause the highest notes in the range of a tone to become distorted.		To change the pitch in semitone steps (Transpose) (page EN-20)
Octave Shift	Changes the pitch of notes in octave units. • Raising the key of the Digital Piano can cause the highest notes in the range of a tone to become distorted.		Octave Shift (page EN-22)
Temper. Type	Temperament Type		Changing the Temperament of the Keyboard (page EN-22)
Temper. Base Note	Temperament Base Note		
Stretch Tune	Stretch tuning. Selects a tuning curve.		To change the tuning curve (Stretch Tuning) (page EN-21)
Tuning	Makes fine adjustments in the pitch of notes.		Fine Tuning (Tuning) (page EN-21)
Layer/Split >Ent	Layer parameters and split parameters • The editing screen can also be displayed by holding down the LAYER button. • The editing screen will not appear if the Digital Piano is in the Duet Mode.		
Upper1 Octave	Layer Upper 1 octave setting	(See the page to the right.)	To change the octave of each layer (page EN-17)
Upper2 Octave	Layer Upper 2 octave setting		
Layer Balance	Layer volume balance		To adjust the volume balance between two layered tones (page EN-16)
Lower Octave	Split Lower Octave setting		To modify split settings (page EN-18)
Lower Volume	Split lower volume setting		
Split Point	Split point setting		
Lower Pedal	Lower Pedal. Selects whether or not damper pedal operations affect the lower range tones when the keyboard is split.		

Display Text	Description	Settings	Go here for more information
Concert Play >Ent	Concert play parameters • The editing screen can also be displayed by holding down the 17 CONCERT PLAY button.		
Volume	Playback volume	(See the page to the right.)	To adjust the playback volume level of a Concert Play song (page EN-25)
Song >Ent	Song data parameters • The editing screen can also be displayed by holding down the 18 SONG button.		
MIDI Volume	Music Library, MIDI Recorder, Standard MIDI file, Grand Piano demo song playback volume	(See the page to the right.)	To adjust the playback volume level of a MIDI Recorder song (page EN-34) To adjust the playback volume level of song data (page EN-27)
Audio Volume	Audio Recorder song playback volume		To adjust the playback volume level of song data (page EN-27)
ML Clear >Ent	User music library clear 1. Use the 21 \blacktriangledown and \blacktriangle arrow buttons to select the number of the song to be deleted and then press the 22 ENTER button. • This will cause the confirmation message "Sure?" to appear. 2. Press the 21 \blacktriangleright arrow button to delete. • To cancel, press the 21 \blacktriangleleft arrow button. • The message "Please Wait..." will remain on the display while the operation is being performed. Do not perform any operation while this message is on the display. "Complete!" appears on the display after the operation is complete.	–	–
Audio Delete >Ent	Deletes the currently selected Audio Recorder song.	–	To delete the currently selected Audio Recorder song data (page EN-37)
Recorder >Ent	Record function parameters • The editing screen can also be displayed by holding down the 16 REC button.		
Recorded Part	Recorded part playback	(See the page to the right.)	To record the other track of a song (page EN-33)
Part Clear >Ent	Track delete	–	To delete recorded data (page EN-34)
Precount	Precount prior to a song	(See the page to the right.)	To configure precount settings (page EN-33)
Audio Rec with MIDI	For audio recording, you can select whether or not a Music Library or MIDI Recorder song should be played back during recording.		To record keyboard play while playing back a MIDI Recorder song or song data (page EN-36)

Display Text	Description	Settings	Go here for more information
Metronome >Ent	Metronome function parameters <ul style="list-style-type: none"> The editing screen can also be displayed by holding down the 8 METRONOME button. 		
Tempo	Metronome tempo	(See the page to the right.)	Using the Metronome (page EN-19)
Beat	Metronome beat <ul style="list-style-type: none"> This setting cannot be changed while playback of a Music Library song is in progress. 		
Volume	Metronome volume level		
General >Ent	Other Digital Piano parameters		
LCD Contrast	Digital Piano display contrast	(See the page to the right.)	Adjusting Display Contrast (page EN-7)
Auto Resume	Digital Piano setup backup. When this setting is enabled, the Digital Piano remembers its current settings when it is turned off, and restores them the next time power is turned on. <ul style="list-style-type: none"> The settings below are not remembered. Song part (LR) selection, Operation lock, Local Control, Concert Play song mode (LISTEN, PLAY), Concert Play song tempo 	Off (Disabled), On (Enabled)	–
Auto Power Off	Auto Power Off	(See the page to the right.)	Auto Power Off (page EN-6)
Operation Lock	Operation lock.		Operation Lock (page EN-7)
Half Pedal Pos.	Half pedal position		To adjust the half pedal trigger position (page EN-11)
Headphone Mode	Headphone mode. The Headphone Mode automatically performs timbre compensation while headphones are being used to reproduce the natural expanse of sound that reaches the ears when an acoustic piano is played. The initial default setting is “On”. <ul style="list-style-type: none"> On: Enabled; Off: Disabled 	Off (Disabled), On (Enabled)	–
Volume Sync EQ	Volume sync equalizer. Automatically performs timbre compensation in accordance with the volume level. This feature ensures that low range and/or high range sounds are easier to hear, even at low volume levels. The initial default setting is “Normal”. <ul style="list-style-type: none"> Off: Compensation disabled; Weak: Weak compensation; Normal: Normal compensation; Strong: Strong compensation This function is intended for use with sound output by the Digital Piano’s speakers. When outputting from the Digital Piano’s LINE OUT R and/or L/MONO terminal, you can switch to a timbre suitable for line out. To do so, plug headphones into the Digital Piano’s PHONES jack, and then disable both the Headphone Mode and Volume Sync Equalizer. 	Off (Disabled), Weak, Normal, Strong	–
Factory Reset >Ent	Return system to initial factory defaults.	–	Returning the Digital Piano to Its Factory Default Settings (page EN-7)

Display Text	Description	Settings	Go here for more information
MIDI >Ent	MIDI parameters		
Local Control	Local Control. Selecting “Off” for Local Control cuts off the Digital Piano’s sound source, so no sound is produced by the Digital Piano when keys are pressed. <ul style="list-style-type: none"> Performing certain Digital Piano operations may cause Local Control to turn on automatically. 	Off (Disabled), On (Enabled)	
Keyboard CH	Send channel. Specifies one of the MIDI channels (1 through 16) as the Send Channel, which is used for sending MIDI messages to an external device.	1 to 16	
USB Flash >Ent	USB flash drive parameters		
Load >Ent	Load data from USB flash drive into Digital Piano memory.	–	Loading USB Flash Drive Data into Digital Piano Memory (page EN-50)
Save >Ent	Save data from Digital Piano memory to USB flash drive.	–	Saving Digital Piano Data to a USB Flash Drive (page EN-49)
Delete >Ent	Delete data from USB flash drive.	–	Deleting USB Flash Drive File (page EN-51)
Rename >Ent	Rename file on USB flash drive.	–	Renaming a USB Flash Drive File (page EN-51)
Format >Ent	Format USB flash drive.	–	To format a USB flash drive (page EN-48)

USB Flash Drive

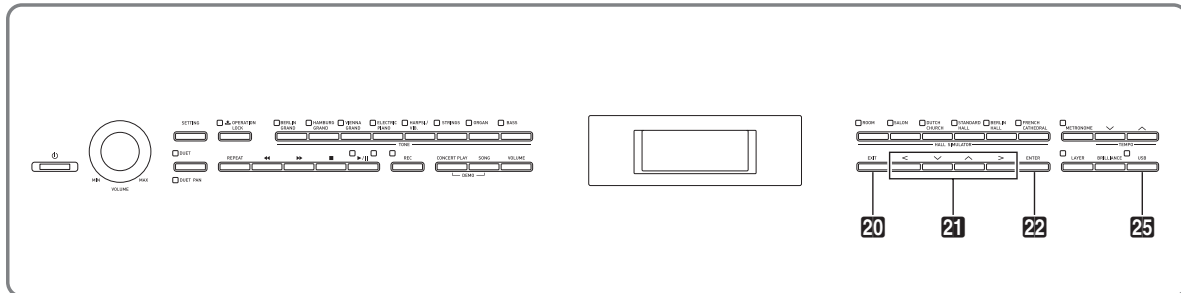

Your Digital Piano supports the following USB flash drive operations.

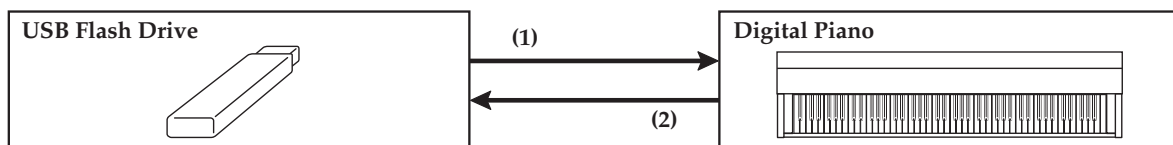

(1) USB Flash Drive on the Digital Piano

1-1. Playing back audio data

- Audio Recorder songs
 - ☞ Playing Back Song Data Stored on a USB Flash Drive (page EN-27)
- General audio data
 - ☞ Saving Standard Song Data to a USB Flash Drive (page EN-48)
- Concert Play songs obtained with a computer, etc.
 - ☞ Concert Play Songs Obtained with a Computer, etc. (page EN-25)

1-2. Loading data into Digital Piano Memory

- MIDI Recorder songs
 - ☞ Loading USB Flash Drive Data into Digital Piano Memory (page EN-50)

1-3. Deleting Data

- ☞ Deleting USB Flash Drive File (page EN-51)

(2) Saving Digital Piano Data to a USB Flash Drive

- Audio Recorder songs*
 - ☞ Audio Recorder (Recording to a USB Flash Drive) (page EN-35).
 - * During recording of an Audio Recorder song, the data is stored directly to the USB flash drive, so a save operation is not required.
- MIDI Recorder songs
 - ☞ Saving Digital Piano Data to a USB Flash Drive (page EN-49)

Preparing a USB Flash Drive

This section explains the information below, which is required to prepare a USB flash drive before using it with the Digital Piano.

- USB flash drive supported for use with the Digital Piano
- Data types supported by the Digital Piano using a USB flash drive
- Connecting a USB flash drive to and detach it from the Digital Piano
- Formatting a USB flash drive

Supported USB Flash Drives

Capacity: 32GB or less recommended

⚠ CAUTION

- Operation of the above type of USB flash drive has been confirmed, but this does not guarantee operation.
- Use a FAT (FAT32) format USB flash drive.
- You may not be able to use a USB flash drive that is recognized as multiple drives on your computer.
- A USB flash drive that is recognized as a CD-ROM on your computer is not supported.
- A USB flash drive with an anti-virus function and/or security functions is not supported.

Data Types Supported by the Digital Piano

Audio Data

- WAV format:
Standard audio file format mainly used by Windows. This format needs to be supported in order to play back on a computer or portable music player. Linear PCM, 16-bit, 44.1kHz, stereo WAV format (File name extension: .WAV) is required for playback on a computer or portable music player.

MIDI data

- CSR format:
CASIO original file format. This file format adds CASIO proprietary data to MIDI data. (File name extension: .CSR)
- CM2 format:
CASIO original file format. This file format adds CASIO proprietary data to MIDI data. CM2 format files can be purchased from the CASIO music website. (File name extension: .CM2)
- SMF (Standard MIDI File) Format 0/1:
Standard MIDI file format that can be exchanged with a compatible device from another manufacturer. (File name extension: .MID)

Data Type		File Name Extension	Save (Digital Piano → USB Flash Drive)	Load (USB Flash Drive → Digital Piano)	Direct Recording to USB Flash Drive	Direct USB Flash Drive Playback
Audio Data	Audio Recorder song file (page EN-30)	.WAV	–	– *1	Yes	Yes
	General audio file		–	–	–	
MIDI data	MIDI Recorder song files (page EN-30)	.CSR	Yes *2	Yes *4	No	
	CASIO MIDI file *3	.CM2	–		–	
	Standard MIDI file (SMF format)	.MID	Yes		No	

*1 Since data can be directly recorded to and played back from a USB flash drive, there is no need to store it from or load it into Digital Piano memory.

*2 Can be converted to Standard MIDI file (SMF format 0, File name extension: .MID) for save.

– Saving as a CSR format file

In addition to performance information, model-specific settings (such as Acoustic Simulator) are also saved to the file, so you can reproduce the original performance in its entirety after re-loading the data. Note, however, that CSR file data is not compatible with other musical instrument types and models.

– Saving as an SMF format file

Performance information is saved, but models specific settings are not saved. Because of this, playback of a re-loaded file will be in accordance with the current Digital Piano setup, which may be different from the original setup. If you want to play with the original setup, you will need to configure it manually. Since this is an SMF file, it can be used on another musical instrument that supports SMF. Of course, playback will be somewhat different when played on another musical instrument.

*3 Songs downloaded from the CASIO website, etc.

*4 Data can be loaded to Music Library Songs 61 to 70. For more information, see “Loading USB Flash Drive Data into Digital Piano Memory” (page EN-50).

To connect a USB flash drive to and to detach it from the Digital Piano

IMPORTANT!

- Be sure to observe the precautions provided in the documentation that comes with the USB flash drive.
- Avoid using a USB flash drive under the following conditions. Such conditions can corrupt data stored on the USB flash drive.
 - Areas subjected to high temperature, high humidity, or corrosive gas
 - Areas subjected to strong electrostatic charge and digital noise
- Never remove the USB flash drive while data is being written to or loaded from it. Doing so can corrupt the data on the USB flash drive and damage the USB flash drive port.
- Never insert anything besides a USB flash drive into the USB flash drive port. Doing so creates the risk of malfunction.
- When you plug in a USB flash drive, the Digital Piano initially needs to “mount” the USB flash drive and prepare for data exchange. Note that Digital Piano operations are momentarily disabled while a USB flash drive mounting sequence is being performed, which is indicated by the **USB** button lamp flashing. The lamp will stop flashing and remain lit after mounting is complete. It may take up to 10 or 20 seconds or even longer for a USB flash drive to be mounted. Do not attempt to perform any operation on the Digital Piano while a mounting sequence is in progress. A USB flash drive needs to be mounted each time it is connected to the Digital Piano.

■ To insert a USB flash drive

1. As shown in the illustration below, insert the USB flash drive into the Digital Piano’s USB flash drive port.
 - Carefully push the USB flash drive in as far as it will go. Do not use undue force when inserting the USB flash drive.

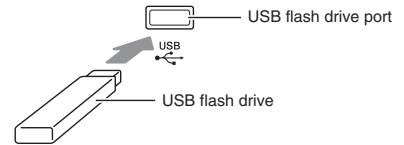

- Static electricity conducted to the USB flash drive port from your hand or from a USB flash drive can cause malfunction of the Digital Piano. If this happens, turn the Digital Piano off and then back on again.

■ To remove a USB flash drive

1. Check to confirm that there is no data exchange operation being performed, and then pull the USB flash drive straight out.
 - A USB flash drive can become warm after very long use. This is normal and does not indicate malfunction.

To format a USB flash drive

Formatting a USB flash drive on the Digital Piano will automatically create the folders described below.

- MUSICDAT: Stores the following types of data:
Auto recording/playback songs,
Music Library songs, MIDI songs, etc.
- CP: Concert Play songs obtained with a computer,
etc.

IMPORTANT!



- Be sure to format a USB flash drive on the Digital Piano before using it for the first time.
- Before formatting a USB flash drive, make sure it does not have any valuable data stored on it.
- The format operation performed by this Digital Piano is a “quick format”. If you want to completely delete all of the data in USB flash drive, format it on your computer or some other device.

NOTE



- This Digital Piano supports USB flash drives formatted to FAT32. If your USB flash drive is formatted to a different file system, use the Windows format function to reformat it to FAT32. Do not use quick format.

1. Insert the USB flash drive you want to format into the Digital Piano’s USB flash drive port.
2. Press the **25** USB button.

USB FLASH

3. Use the **21**  and  arrow buttons to select “Format”.

Format

4. Press the **22** ENTER button.
 - This will cause the confirmation message “Sure?” to appear.
5. Press the **21**  arrow button to execute the format operation.
 - To cancel the format operation, press the **21**  arrow button.
 - The message “Please Wait...” will remain on the display while the operation is being performed. Do not perform any operation while this message is on the display. “Complete!” appears on the display after the operation is complete.

NOTE

- Formatting a large-capacity USB flash drive can take several minutes.

Saving Standard Song Data to a USB Flash Drive

Even when the file format is WAV (general audio data) or SMF (standard MIDI file), the procedure below can be used to save data to USB flash drive and play it back on the Digital Piano.

1. Connect the USB flash drive to your computer.
2. Move the song data file you want to play back to the MUSICDAT folder on the USB flash drive.
 - For information about playback see “Playing Back Song Data Stored on a USB Flash Drive” (page EN-27).

Copyrights

You are allowed to use recordings for your own personal use. Any reproduction of an audio or music format file, without the permission of its copyright holder, is strictly prohibited under copyright laws and international treaties. Also, making such files available on the Internet or distributing them to third parties, regardless of whether such activities are conducted with or without compensation, is strictly prohibited under copyright laws and international treaties. CASIO COMPUTER CO., LTD. shall not be held in any way liable for any use of this Digital Piano that is illegal under copyright laws.

Saving Digital Piano Data to a USB Flash Drive

Digital Piano memory data (MIDI recorder songs) can be saved to a USB flash drive.

- MIDI Recorder songs can be converted to standard MIDI (SMF) files and stored on the USB flash drive.
- During recording of an Audio Recorder song, the data is stored directly to the USB flash drive, so the operation below is not required.

1. Insert the USB flash drive into the Digital Piano's USB flash drive port.
2. Press the **25** **USB** button.
3. Use the **21** **∨** and **∧** arrow buttons to select "Save" and then press the **22** **ENTER** button.

S a v e

4. Use the **21** **∨** and **∧** arrow buttons to select a file type.
 - MID: Converts the data to an SMF file and saves it to the USB flash drive.
 - CSR: Saves the data as-is (CSR file) to the USB flash drive.
 - For details about file formats, see "Data Types Supported by the Digital Piano" (page EN-46).
5. Use the arrow buttons to change the name as required.
 - Use the **21** **<** and **>** arrow buttons to move the cursor to the input position.
 - Use the **21** **∨** and **∧** arrow buttons to scroll through characters at the current cursor position. Supported input characters are shown in the table below.

0	1	2	3	4	5	6	7	8	9
A	B	C	D	E	F	G	H	I	J
K	L	M	N	O	P	Q	R	S	T
U	V	W	X	Y	Z	@	^	_	`
{	}	~	\$	&	'	()	-	

6. Press the **22** **ENTER** button.
 - This will cause the confirmation message "Sure?" to appear.

7. Press the **21** **>** arrow button to execute the save operation.
 - To cancel the save operation, press the **21** **<** arrow button.
 - The message "Please Wait..." will remain on the display while the operation is being performed. Do not perform any operation while this message is on the display. "Complete!" appears on the display after the operation is complete.

Loading USB Flash Drive Data into Digital Piano Memory

MIDI data (MIDI Recorder songs, songs downloaded from the CASIO website, standard MIDI files, etc.) stored on a USB flash drive can be loaded to Digital Piano memory and stored in Music Library numbers 61 through 70.

NOTE

- To clear the contents of Music Library numbers 61 through 70 (User Music Library) that you loaded from a USB flash drive, see “Configuring Digital Piano Settings” (page EN-38) and the following item in the Parameter List (page EN-39): “Song” → “ML Clear >Ent” (page EN-41).
- For information about playing back audio data stored on a USB flash drive, see “Playing Back Song Data Stored on a USB Flash Drive” (page EN-27).

PREPARATION

- On your computer, copy the files you want to import to Digital Piano memory to the USB flash drive.

1. Insert the USB flash drive into the Digital Piano’s USB flash drive port.
2. Press the **25** USB button.
3. Use the **21** \vee and \wedge arrow buttons to select “Load” and then press the **22** ENTER button.

L o a d
4. Use the **21** \vee and \wedge arrow buttons to select a USB flash drive data number.
5. Use the **21** \leftarrow and \rightarrow arrow buttons to move the cursor to the Digital Piano data numbers.
6. Use the **21** \vee and \wedge arrow buttons to select a Digital Piano data number.
 - Any data number that already contains imported data will be indicated by an asterisk (*) to the left of the data number.
 - Pressing the **21** \leftarrow arrow button moves the cursor to USB flash drive data numbers, so you can select a different USB flash driver data number, if you want.
7. Press the **22** ENTER button.
 - This will cause the confirmation message “Sure?” to appear.

8. Press the **21** \rightarrow arrow button to execute the load operation.
 - To cancel the load operation, press the **21** \leftarrow arrow button.
 - The message “Please Wait...” will remain on the display while the operation is being performed. Do not perform any operation while this message is on the display. “Complete!” appears on the display after the operation is complete.

Deleting USB Flash Drive File

You can use the procedure below to delete a specific file from a USB flash drive.

1. Insert the USB flash drive into the Digital Piano's USB flash drive port.
2. Press the **25**USB button.
3. Use the **21**∨ and ∧ arrow buttons to select "Delete" and then press the **22**ENTER button.

Delete

4. Use the **21**∨ and ∧ arrow buttons to select a data item name.
5. Press the **22**ENTER button.
 - This will cause the confirmation message "Sure?" to appear.
6. Press the **21**> arrow button to execute the delete operation.
 - To cancel the delete operation, press the **21**< arrow button.
 - The message "Please Wait..." will remain on the display while the operation is being performed. Do not perform any operation while this message is on the display. "Complete!" appears on the display after delete is complete.

Renaming a USB Flash Drive File

Use the procedure below to rename a file on a USB flash drive using Digital Piano operations.

1. Insert the USB flash drive into the Digital Piano's USB flash drive port.
2. Press the **25**USB button.
3. Use the **21**∨ and ∧ arrow buttons to select "Rename" and then press the **22**ENTER button.
4. Use the **21**∨ and ∧ arrow buttons to select the file.
5. Use the arrow buttons to rename the file.
 - Use the **21**< and > arrow buttons to move the cursor to the input position.
 - Use the **21**∨ and ∧ arrow buttons to scroll through characters at the current cursor position. Supported input characters are shown in the table below.

0	1	2	3	4	5	6	7	8	9
A	B	C	D	E	F	G	H	I	J
K	L	M	N	O	P	Q	R	S	T
U	V	W	X	Y	Z	@	^	_	`
{	}	~	\$	&	'	()	-	

6. Press the **22**ENTER button.
 - This will cause the confirmation message "Sure?" to appear.
7. Press the **21**> arrow button to execute the rename operation.
 - To cancel the save operation, press the **21**< arrow button.
 - The message "Please Wait..." will remain on the display while the operation is being performed. Do not perform any operation while this message is on the display. "Complete!" appears on the display after delete is complete.

Error Indicators

The table below shows messages that appear on the Digital Piano display when data transfer fails or when another type of error is generated.

- To clear an error display, press the **EXIT** button.

Display	Cause	Action
No Media	<ol style="list-style-type: none"> 1. The USB flash drive is not connected to the Digital Piano's USB flash drive port. 2. The USB flash drive was removed while some operation was in progress. 3. The USB flash drive is write-protected. 4. The USB flash drive has anti-virus software. 5. The Digital Piano is unable to recognize the USB flash drive for some reason. 	<ol style="list-style-type: none"> 1. Correctly plug the USB flash drive into the USB flash drive port. 2. Do not remove the USB flash drive while any operation is in progress. 3. Unprotect the USB flash drive. 4. Use a USB flash drive that does not have anti-virus software. 5. Remove the USB flash drive, turn the Digital Piano off and then back on again, and then correctly load the USB flash drive.
No File	There is no loadable file in the "MUSICDAT" folder or no playable file in the "MUSICDAT" folder.	<ul style="list-style-type: none"> • Format the USB flash drive on the Digital Piano. • Move the file you want to load into the "MUSICDAT" folder or the file you want to play into the "MUSICDAT" folder (page EN-48).
No Data	You are attempting to save data to a USB flash drive when there is no data to save.	Record something before performing a save operation.
Read Only	A read-only file with the same name you are trying to use is already stored on USB flash drive.	<ul style="list-style-type: none"> • Change the name and then save the new data. • Remove the read-only attribute from the existing USB flash drive file and overwrite it with the new data. • Use a different USB flash drive.
Media Full	There is not enough space available on the USB flash drive.	Delete some of the files on the USB flash drive to make room for new data or use a different USB flash drive.
Too Many Files	<ol style="list-style-type: none"> 1. There are too many files on the USB flash drive. 2. There is a file named TAKE99.WAV in the "MUSICDAT" folder. 	<ol style="list-style-type: none"> 1. Delete some of the files on the USB flash drive to make room for new data. 2. Delete the WAV file in the "MUSICDAT" folder.
Not SMF0/1	You are attempting to play back SMF Format 2 song data.	This Digital Piano supports playback of SMF Format 0 or Format 1 only.
Size Over	The data on the USB flash drive is too big to play.	Reduces the size of the data so it can be played.
Wrong Data	<ol style="list-style-type: none"> 1. The USB flash drive data is corrupted. 2. USB flash drive contains data that is not supported by this Digital Piano. 	—
Memory Full	There is not enough Digital Piano memory available to convert a MIDI recorder song to SMF data and store it on the USB flash drive.	Reduce the size of the song data. Example: Delete any tracks that are not required.
Format Error	<ol style="list-style-type: none"> 1. The USB flash drive format is not compatible with this Digital Piano. 2. The USB flash drive is corrupted. 	<ol style="list-style-type: none"> 1. Format the USB flash drive on the Digital Piano. 2. Use a different USB flash drive.
Media Error	The USB flash drive is corrupted.	Use a different USB flash drive.
File Name Error	<ol style="list-style-type: none"> 1. When renaming a file on a USB flash drive, you specified a new file name that is already used for another file on the USB flash drive. 2. You are attempting to play a Concert Play song data obtained with a computer, etc. when there are no files in the "CP" folder. Or the file names are wrong. 	<ol style="list-style-type: none"> 1. Rename to a different file name. 2. Change name part (the part to the left of the file name extension) of the Concert Play song files (both the .LSN and .PLY files) to the same name. Next, place the files into the "CP" folder.

Connecting to a Computer

You can connect the Digital Piano to a computer and exchange MIDI data between them. You can send play data from the Digital Piano to commercially available music software running on your computer, or you can send MIDI data from your computer to the Digital Piano for playback.

Minimum Computer System Requirements

The following shows the minimum computer system requirements for sending and receiving MIDI data. Check to make sure that your computer complies with these requirements before connecting the Digital Piano to it.

- Operating System
 - Windows Vista® *1
 - Windows® 7*2
 - Windows® 8 *3
 - Windows® 8.1 *4
 - Mac OS® X (10.3.9, 10.4.11, 10.5.X, 10.6.X, 10.7.X, 10.8.X, 10.9.X)
- *1: Windows Vista (32-bit)
- *2: Windows 7 (32-bit, 64-bit)
- *3: Windows 8 (32-bit, 64-bit)
- *4: Windows 8.1 (32-bit, 64-bit)

- USB port

IMPORTANT!

- Never connect to a computer that does not conform to the above requirements. Doing so can cause problems with your computer.

NOTE

- For the latest news about supported operating systems, visit the website at the URL below.
<http://world.casio.com/>

Connecting the Digital Piano to Your Computer

IMPORTANT!

- Make sure you follow the steps of the procedure below exactly. Connecting incorrectly can make data send and receive impossible.

1. Turn off the Digital Piano and then start up your computer.
 - Do not start up the music software on your computer yet!

2. After starting up your computer, use a commercially available USB cable to connect it to the Digital Piano.

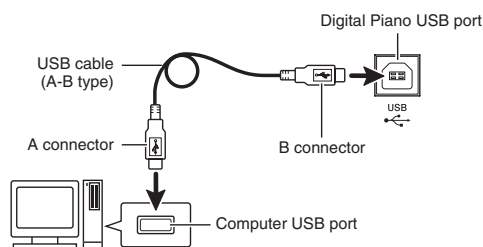

3. Turn on the Digital Piano.
 - If this is the first time you are connecting the Digital Piano to your computer, the driver software required to send and receive data will be installed on your computer automatically.
4. Start up commercially available music software on your computer.
5. Configure the music software settings to select “CASIO USB-MIDI” as the MIDI device.
 - For information about how to select the MIDI device, see the user documentation that comes with the music software you are using.

IMPORTANT!

- Be sure to turn on the Digital Piano first before starting up your computer's music software.

NOTE

- Once you are able to connect successfully, there is no problem with leaving the USB cable connected when you turn off your computer and/or Digital Piano.
- For detailed specifications and connections that apply to MIDI data send and receive by this Digital Piano, see the latest support information provided by the website at the following URL.
<http://world.casio.com/>

Using MIDI

What is MIDI?

The letters MIDI stand for Musical Instrument Digital Interface, which is the name of a worldwide standard for digital signals and connectors that makes it possible to exchange musical data between musical instruments and computers (machines) produced by different manufacturers.

- For details about MIDI parameters, see “Configuring Settings” on page EN-38, and “MIDI >Ent” in the “Parameter List” on page EN-39.
- To connect the Digital Piano to another electronic musical instrument for performance using MIDI data, use the above USB cable, a separately available MIDI cable that is compatible with both connectors, or a commercially available MIDI cable to connect them.

NOTE

- For detailed information about MIDI Implementation, visit the CASIO website at: <http://world.casio.com/>.

Getting Ready

Assembling the Stand

Before assembling the stand, first take a few moments to check that all of the items shown below are present.

- This stand does not include any of the tools required for assembly. It is up to you to prepare a large Philips head (+) screwdriver for assembly.

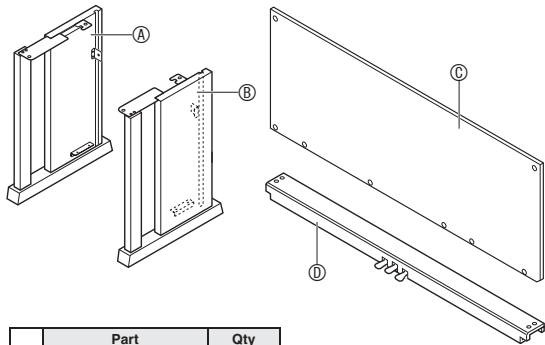

	Part	Qty
E		4
F		6
G		1
H		2
I		4
J		4
K		1
L		1
M		1

IMPORTANT!

- Do not use any screws other than those that come with the stand. Doing so risks damage to the stand and/or Digital Piano.
- You can find the screws in a plastic bag inside of the packing material.
- If anything is missing or damaged, contact your local CASIO service provider.

CAUTION

- Assembly of the stand should be performed by at least two people working together. The Digital Piano unit is particularly heavy. When moving it, get at least one other person to help you and handle with care.

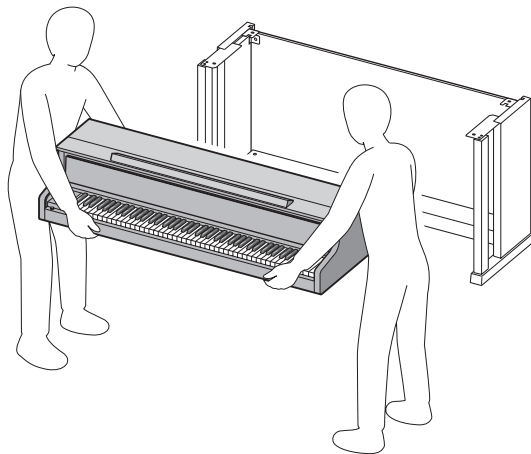

- This stand should be assembled on a flat surface.
- Do not remove the tape securing the keyboard cover in place until assembly is complete. Removing the tape can cause the keyboard cover to open and close during assembly, creating the risk of personal injury to your hands and fingers.
- Take care that you do not pinch your fingers between parts when assembling them.
- When placing the Digital Piano on the floor, be sure to place it on something soft (a blanket, cushion, etc.). Do not place the Digital Piano directly onto the floor.

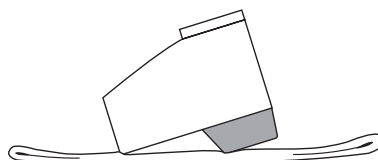

1. Unfasten the band ① that bundles the pedal cable to the back of crosspiece ④ and pull the pedal cord out from the crosspiece.

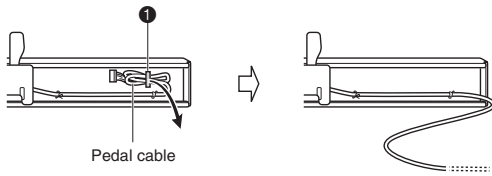

2. Attach side panels ① and ② to crosspiece ④. Secure the side panels using four screws ⑤.

- When installing parts ②, slide the brackets ③ into the slots in either end of crosspiece ④. If the brackets ③ are not inserted into the ends of the crosspiece ④ as far as they will go, the screws ⑤ will not be able to enter into the screw holes of the brackets ③, which can strip the threads of the screws.
- Cover the screw heads with the caps ⑥.

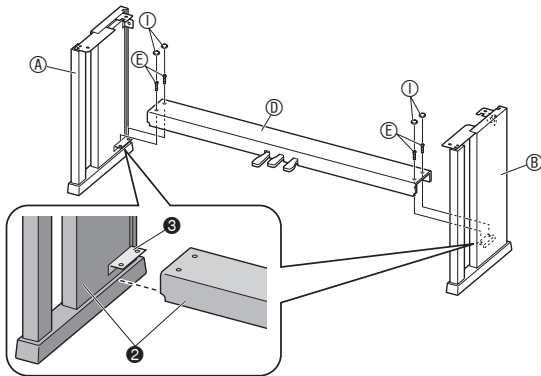

3. Slide back panel ③ into the grooves ④ of the side panels.

- When installing back panel ③, make sure that the widely spaced screw holes along the bottom of the panel are on the left (when viewed from the front of the stand), and the narrowly spaced holes are on the right.

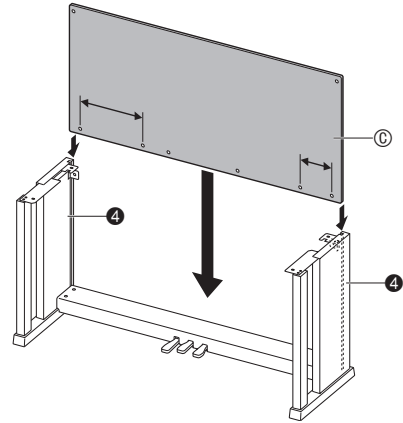

4. Use the two screws ⑧ to secure the top left and right edges of the back panel ③ to the brackets ⑤ of side panels ① and ②.

- At location ⑥, slip the clip ⑦ onto to the screw ⑧ before installing the screw.

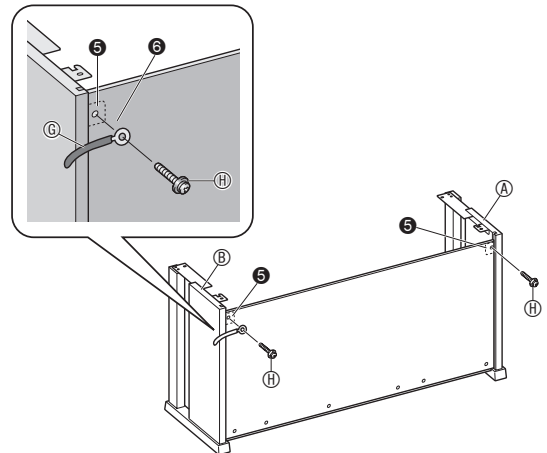

5. Next, secure the bottom of the back panel ③ with the six ④ screws.

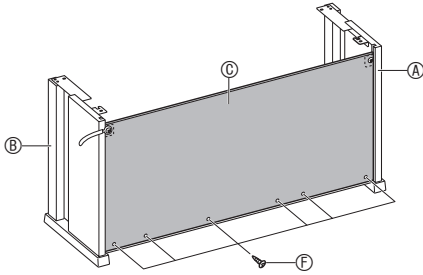

6. Adjust the height adjustment screw ⑦ to provide support so crosspiece ⑧ does not bow downwards when the pedals are pressed.

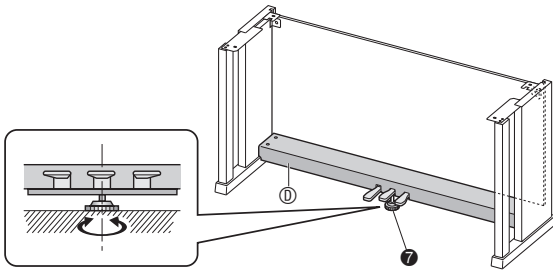

IMPORTANT!

- Pressing the pedals without adjusting height adjustment screw ⑦ can result in damage to crosspiece ⑧. Always make sure you adjust height adjustment screw ⑦ before operating the pedals.

7. Place the piano onto the stand.

IMPORTANT!

- In order to ensure you do not get your fingers pinched between the piano and the stand, grasp the piano on its sides (not its ends) at the locations marked with stars (★) in the illustration.

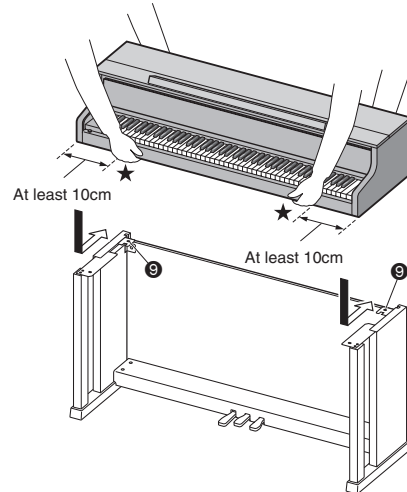

- At this time the screws on the bottom of the piano ⑤ should hook into the cutouts in the stand brackets ⑥.

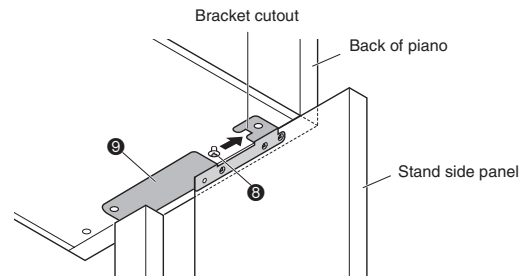

8. First, use the two screws ① to secure the back of the piano (both left and right side) to the stand. Next, use the two screws ② to secure the front of the piano (both left and right side).

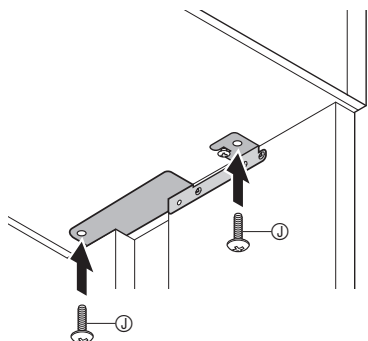

IMPORTANT!

- The screws ① keep the piano from slipping off the stand. Never use the piano without the screws ① installed.

9. Affix the adaptor cord clip ③ next to the power terminal (DC 24V).

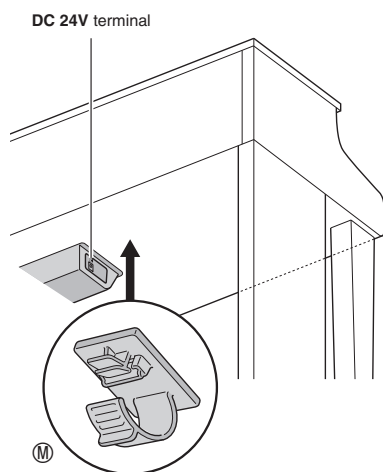

To connect the cables

1. Insert the plug of the AC adaptor that comes with the Digital Piano into its power terminal (DC 24V).

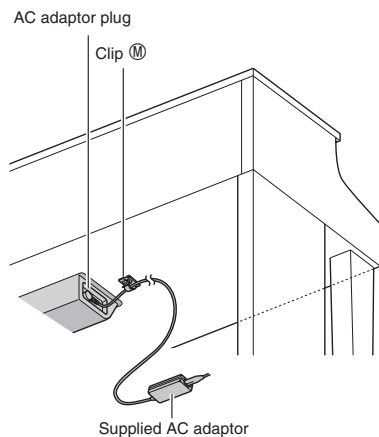

Using the Clip ③

- To fasten the clip
As shown in the illustration, press down on (a) to force the tip of the clip into the slot. Press down until you hear the clip click securely into place.

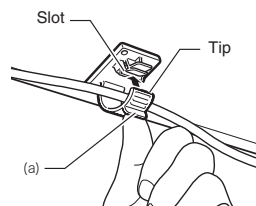

- To release the clip
As shown in the illustration, press (b) in the direction indicated by the arrow.

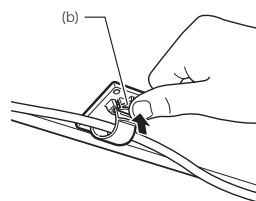

Handling Precautions

Be sure to insert felt or other material between the rubber feet and flooring. Do not allow direct contact between them. Some types of flooring material may become discolored or damaged by direct contact with the rubber feet.

2. Orienting the pedal plug as shown in the illustration, plug it into the pedal connector on the bottom of the piano.

- Secure the pedal cord with the clip ⑥.

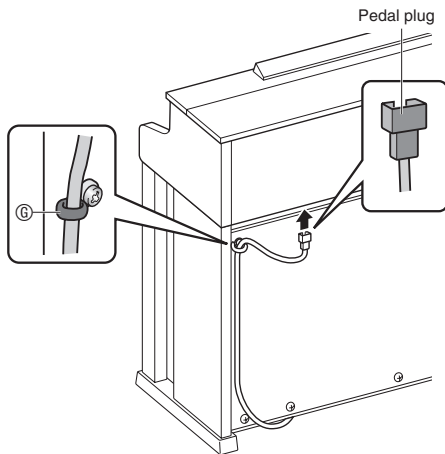

3. Plug the power cord of the AC adaptor that comes with the Digital Piano into a household power outlet as shown in the illustration below.

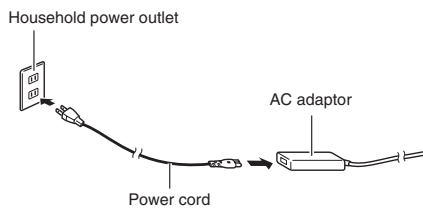

Keyboard Cover

Make sure that the cover is full open whenever you are playing on the keyboard. A partially open cover can suddenly close unexpectedly and pinch your fingers. Also take care to avoid pinching your fingers whenever opening or closing the keyboard cover.

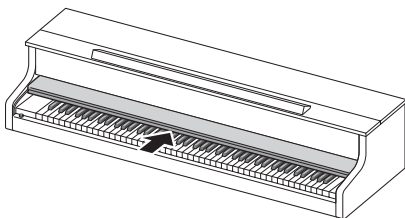

To install the music stand and headphones hook

1. Insert music stand into the groove on the Digital Piano console as shown in the figure below.

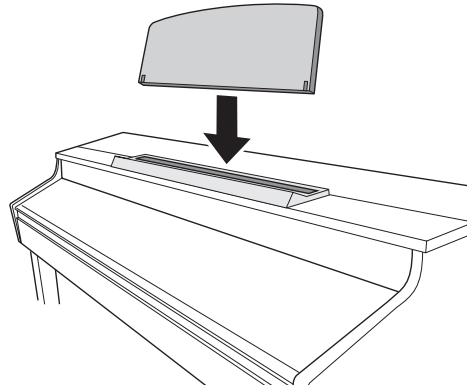

2. Install the headphones hook.

- 2-1. Insert the headphones hook ⑫ into the two holes on the bottom of the piano.
- 2-2. Use screw ⑬ to secure the headphones hook in place.

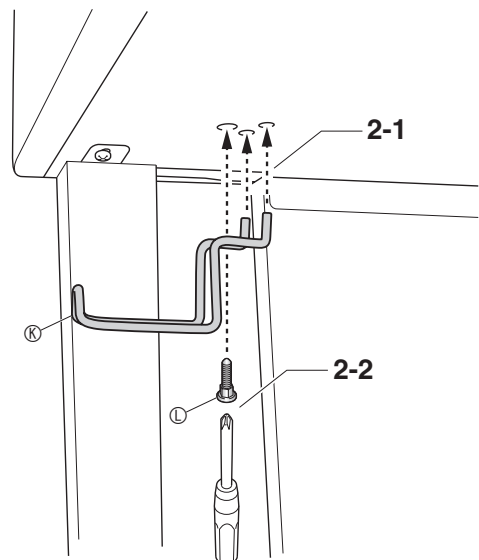

Opening and Closing the Piano Lid

IMPORTANT!

- Use both hands whenever opening or closing the lid, and take care that you do not close it on your fingers.
- Do not open the lid too wide. Doing so creates the risk of damage to the cover and Digital Piano.
- Stand in front of the Digital Piano on the right side when opening or closing the lid.

To open the lid

1. Lift up the lid as shown in the illustration.

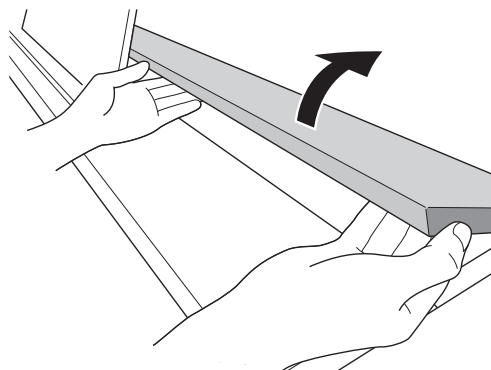

- The lid has a support bracket (indicated by the star ★ in the illustration) attached to its inside surface. Check to make sure that the support bracket is standing up fully.

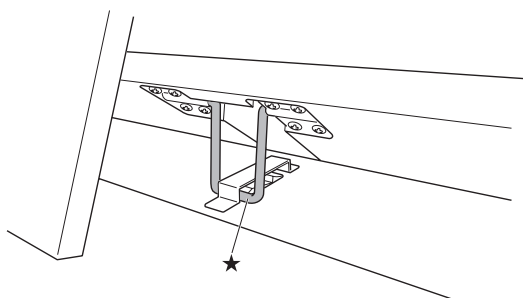

To close the lid

1. Carefully lift up slightly on the lid.
2. Use the fingers of your left hand to press back on the support bracket (★) as you slowly and carefully lower the lid.

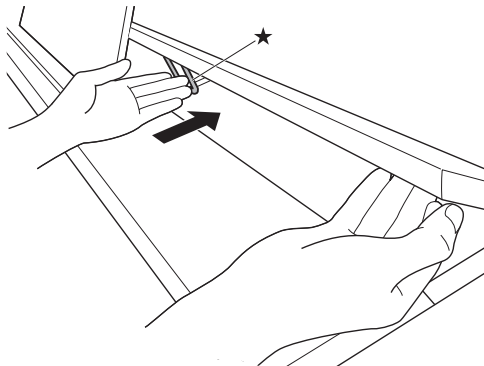

- The support bracket is designed to prevent sudden closing of the lid. Should the support bracket stop moving, once again press back on it (★) as you slowly and carefully lower the lid.

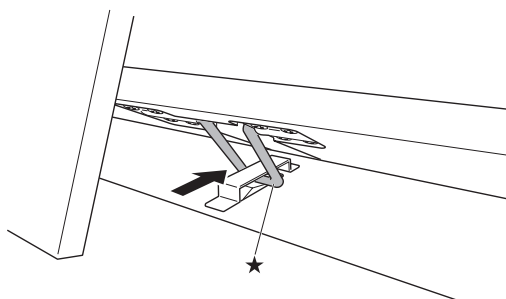

Removing the Protective Tape from the Keyboard

Protective tape is affixed to the front edges of the keyboard keys to protect them during shipment. Remove the protective tape before using the Digital Piano.

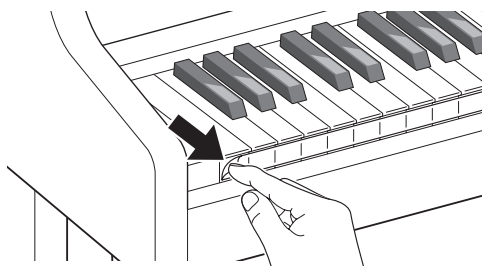

Power Outlet

Your Digital Piano runs on standard household power. Be sure to turn off power whenever you are not using the Digital Piano.

Using an AC Adaptor

Use only the AC adaptor (JEITA Standard, with unified polarity plug) that comes with this Digital Piano. Use of a different type of AC adaptor can cause malfunction of the Digital Piano.

Specified AC Adaptor: AD-E24500LW

- Use the supplied power cord to connect the AC adaptor.

! IMPORTANT!

- Never connect the AC adaptor that comes with this Digital Piano to any other device besides this Digital Piano. Doing so creates the risk of malfunction.
- Make sure the Digital Piano is turned off before plugging in or unplugging the AC adaptor.
- The AC adaptor will become warm to the touch after very long use. This is normal and does not indicate malfunction.
- Unplug the AC adaptor from the power outlet if you do not plan to use the Digital Piano for a long time.

■ Disconnect Protection Precautions

- (1) Never pull on the cord with excessive force.
- (2) Never repeatedly pull on the cord.
- (3) Never twist the cord at the base of the plug or connector.
- (4) Loop and bundle the power cord, but never wind it around the AC adaptor.
- (5) Before moving the Digital Piano, be sure to unplug the AC adaptor from the power outlet.

■ Locating the AC Adaptor for Use

- When using the AC adaptor, put in a location that satisfies the conditions below.
 - A location free of splashing liquids
The AC adaptor is designed for indoor use only. Do not put it in a location where it may become wet and do not place a vase or any other container of liquid on top of it.
 - A location that is not humid.
 - A roomy, well ventilated location
Do not cover the AC adaptor with newspaper, table cloth, curtain, or any other type of fabric.
 - Use a power outlet that is located near the Digital Piano.
This will let you immediately unplug from the power outlet should any problem occur.
- When using the AC adaptor, place it on the floor with its label surface downwards. The AC adaptor becomes prone to emitting electromagnetic waves when the label surface is facing upwards.

Connecting Headphones

Front

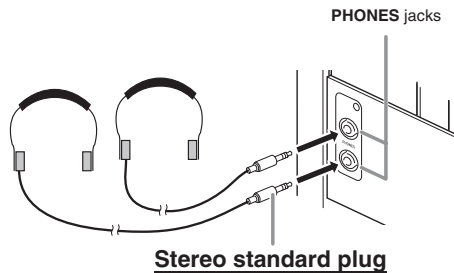

Connect commercially available headphones to the **PHONES** jacks. Connecting headphones to either of the **PHONES** jack cuts off output to the speakers, which means you can practice even late at night without bothering others. To protect your hearing, make sure that you do not set the volume level too high when using headphones.

NOTE

- Be sure to push the headphones plug into the **PHONES** jacks as far as it will go. If you don't, you may hear sound from only one side of the headphones.
- If the plug of the headphones you are using does not match the **PHONES** jacks, use the applicable commercially available adaptor plug.
- If you are using headphones that require an adaptor plug, make sure you do not leave the adaptor plugged in when you unplug the headphones. If you do, nothing will sound from the speakers when you play.

Headphone Mode

The Headphone Mode reproduces the natural expanse of sound that reaches the ears when an acoustic piano is played.

- The Headphone Mode is enabled only while headphones are being used.
- If external output is used while headphones are plugged into the PHONE jack, the external output sound is also the result of Headphone Mode compensation.
- The Headphone Mode is enabled under initial default settings. To disable the Headphone Mode, see "Configuring Settings" on page EN-38, and "General" → "Headphone Mode" in the "Parameter List" on page EN-39.

Connecting Audio Equipment or an Amplifier

You can connect audio equipment or a music amplifier to the Digital Piano and then play through external speakers for more powerful volume and better sound quality.

IMPORTANT!

- The Digital Piano automatically adjusts sound output to optimize for headphone output (when headphones are connected) or built-in speaker output (when headphones are not connected).
- When outputting from the Digital Piano's **LINE OUT R** and/or **L/MONO** terminal, you can switch to a timbre suitable for line out. To do so, plug headphones into the Digital Piano's **PHONES** jack, and then disable both the Headphone Mode and Volume Sync Equalizer. For more information, see "Headphone Mode" and "Volume Sync Equalizer" (page EN-42).
- Whenever connecting a device to the Digital Piano, first use the **2 VOLUME** controller to set the volume to a low level. After connecting, you can adjust the volume to the level you want.
- Whenever you connect any device to the Digital Piano, be sure to read the user documentation that comes with the device.

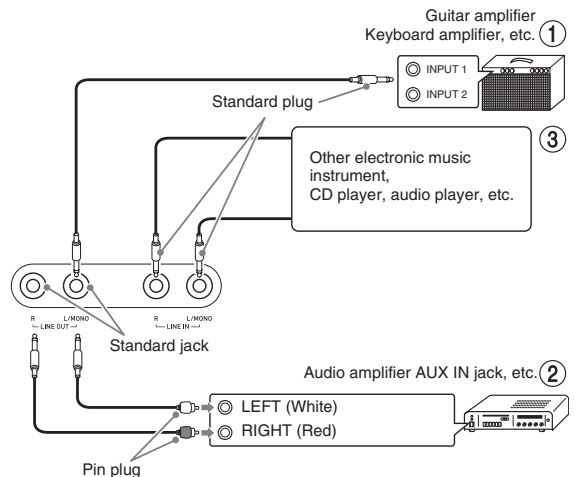

To output to a musical instrument amplifier (Figure ①)

Use commercially available cables to connect the amplifier to the Digital Piano's **LINE OUT** jacks as shown in Figure ①. **LINE OUT R** jack output is right channel sound, while **LINE OUT L/MONO** jack output is left channel sound. Connecting to the **LINE OUT L/MONO** jack only outputs a mixture of both channels. It is up to you to purchase connecting cable like the one shown in the illustration for connection of the amplifier. Use the Digital Piano's **VOLUME** controller to adjust the volume level.

To output to audio equipment (Figure ②)

Use commercially available cables to connect the external audio equipment to the Digital Piano's **LINE OUT** jacks as shown in Figure ②. **LINE OUT R** jack output is right channel sound, while **LINE OUT L/MONO** jack output is left channel sound. It is up to you to purchase connecting cables like the ones shown in the illustration for connection of audio equipment. Normally in this configuration you must set the audio equipment's input selector to the setting that specifies the terminal (such as **AUX IN**) to which the piano is connected. Use the Digital Piano's **VOLUME** controller to adjust the volume level.

To input from audio equipment (Figure ③)

Connect the Digital Piano's **LINE IN R** and **LINE IN L/MONO** terminals to the audio equipment as shown in Figure ③. Use commercially available connection cords that match the equipment being connected to. Connecting a cord to **LINE IN L/MONO** only will cause the left and right channels to be mixed and output from both **LINE OUT R** and **LINE OUT L/MONO**.

Bundled and Optional Accessories

Use only accessories that are specified for use with this Digital Piano.

Use of unauthorized accessories creates the risk of fire, electric shock, and personal injury.

NOTE

- You can get information about accessories that are sold separately for this product from the CASIO catalog available from your retailer, and from the CASIO website at the following URL.
<http://world.casio.com/>

Troubleshooting

Problem	Cause	Action	See Page
No sound is produced when I press a keyboard key.	<ol style="list-style-type: none"> The VOLUME controller is set to "MIN". Headphones or an adaptor plug is plugged into one of the PHONES jacks. MIDI Local control is turned off. 	<ol style="list-style-type: none"> Rotate the VOLUME controller more towards "MAX". Disconnect whatever is connected to the PHONES jacks. Turn on the Local control setting. 	<p>☞ EN-6</p> <p>☞ EN-62</p> <p>☞ EN-43</p>
The pitch of the Digital Piano is off.	<ol style="list-style-type: none"> Digital Piano tuning is incorrect. The Digital Piano's key setting is something other than "440.0Hz". Octave shift is enabled. A non-standard temperament setting is being used. 	<ol style="list-style-type: none"> Adjust Digital Piano tuning, or turn the Digital Piano off and then back on again. Change the key setting to "440.0Hz", or turn Digital Piano power off and then back on again. Change the octave shift setting to 0. Change the temperament setting to "00: Equal", which is the standard modern tuning. 	<p>☞ EN-40</p> <p>☞ EN-40</p> <p>☞ EN-22</p> <p>☞ EN-22</p>
Nothing happens when I press a pedal.	<ol style="list-style-type: none"> The pedal unit cable is not connected. The pedal unit cable plug is not plugged in completely. 	<ol style="list-style-type: none"> Connect the cable correctly. Make sure that the pedal unit cable plug is inserted as far as it will go into the pedal connector on the bottom of the Digital Piano. 	☞ EN-58
Tones and/or effects sound strange. Turning power off and then back on again does not eliminate the problem. <i>Example: Note intensity does not change even though I alter key pressure.</i>	The "Auto Resume" feature is turned on.	Turn off "Auto Resume". Next, turn power off and then back on again.	☞ EN-42
I cannot transfer data after connecting the Digital Piano to a computer.	–	<ol style="list-style-type: none"> Check to make sure that the USB cable is connected to the Digital Piano and computer, and that the correct device is selected with your computer's music software. Turn off the Digital Piano and then exit the music software on your computer. Next, turn the Digital Piano back on and then restart the music software on your computer. 	☞ EN-53
I cannot store data to a USB flash drive or load data from a USB flash drive.	–	See "Error Indicators".	☞ EN-52
It takes a long time before I can use the Digital Piano after I turn it on.	Digital Piano memory data was corrupted because a data transfer operation with a computer was in progress the last time you turned off the Digital Piano. When this happens, the Digital Piano performs a memory format operation the next time you turn it on. You cannot perform any other operation while a format operation is in progress.	It takes about 20 seconds after you turn on power to perform the memory format operation. Wait until the format operation is complete. Note that you should take care to avoid turning off the Digital Piano while a data transfer operation with a computer is in progress.	☞ EN-53

Problem	Cause	Action	See Page
A tone's quality and volume sounds slightly different depending where it is played on the keyboard.	This is an unavoidable result of the digital sampling process,* and does not indicate malfunction. * Multiple digital samples are taken for the low range, middle range, and high range of the original musical instrument. Because of this, there may be very slight differences in tonal quality and volume between sample ranges.		
When I press a button, the note that is sounding cuts out momentarily or there is a slight change in how effects are applied.	This happens when the sounds of multiple parts are sounding at the same time while using layer, using the Duet Mode, playing back a built-in tune, recording, etc. Pressing a button when one of these conditions exists will cause the effect setting that is built into the tone to change automatically, which causes notes to cut out momentarily or causes a slight change in how effects are being applied.		
The play-along part (the part played on the Digital Piano) is slightly audible during Play Mode playback.	Certain recording conditions may cause the play-along part to be slightly audible during Play Mode playback. This does not indicate malfunction.		

Product Specifications

Model	AP-700BK
Keyboard	88-key piano keyboard <ul style="list-style-type: none"> • Layer, Split • Duet: Adjustable tone range (-2 to +2 octaves) • Transpose: 2 octaves (-12 to 0 to +12) • Octave shift: 4 octaves (-2 to 0 to +2)
Sound Source	<ul style="list-style-type: none"> • Number of Tones: 26 • Maximum polyphony: 256 tones • Touch Response (3 sensitivity levels, Off) • Tuning: 415.5Hz to 440.0Hz to 465.9Hz (0.1Hz units) • Temperament: Equal temperaments plus 16 other types • Stretch Tuning: 5 types, Off, Auto Setting
Acoustic Simulator	Damper Resonance, Damper noise, Hammer response, String resonance, Lid simulator
Effects	Brilliance (-3 to 0 to 3), Hall simulator (6 types), Chorus (4 types), DSP, Headphone mode, Volume sync equalizer (3 types, Off)
Concert Play	<ul style="list-style-type: none"> • Number of Songs: 15 • Playback of Concert Play songs obtained with a computer, etc. • Song volume: Adjustable • Playback at 80% of normal tempo • 2 Modes: LISTEN, PLAY
Music Library	<ul style="list-style-type: none"> • Number of Songs: 60, User Songs: 10 (Up to approximately 90KB per song, approximately 900KB for 10 songs)* * Based on 1KB = 1024 bytes, 1MB = 1024² bytes • Song volume: Adjustable • Part On/Off: L, R
Grand Piano demo song	6
MIDI Recorder	<ul style="list-style-type: none"> • Functions: Real-time recording, playback • Number of Song: 1 • Number of Tracks: 2 • Capacity: Approximately 5,000 notes total • Recorded Data Protection: Built-in flash memory • MIDI Recorder Volume Level: Adjustable
Audio Recorder	<ul style="list-style-type: none"> • Real-time recording and playback to USB flash drive* <ul style="list-style-type: none"> * Linear PCM, 16bit, 44.1 kHz, stereo .WAV format • Songs: 99 files • Approximately 25 minutes maximum recording per file. • Audio Recorder Volume Level: Adjustable
Metronome	<ul style="list-style-type: none"> • Beats: 0 to 9 • Tempo Range: 20 to 255 • Metronome Volume Level: Adjustable
Pedals	Damper (with half-pedal operation), Soft, Sostenuto
Other Functions	<ul style="list-style-type: none"> • Setting backup • Operation Lock
MIDI	16-channel multi-timbre receive
USB Flash Drive	<ul style="list-style-type: none"> • Capacity: 32GB or less recommended • SMF direct playback, data storage, data loading, USB flash drive format, audio data playback and storage

Inputs/Outputs	<ul style="list-style-type: none"> • PHONES jacks: Stereo standard jacks × 2 • Power: 24V DC • MIDI OUT/IN terminals • LINE IN R, L/MONO jacks: Standard jacks × 2 Input impedance: 9.0KΩ Input voltage: 200mV • LINE OUT R, L/MONO jacks: Standard jacks × 2 Output impedance: 2.3KΩ Output voltage: 1.8V (RMS) MAX • USB port : Type B • USB flash drive port : Type A • Pedal connector
Speakers	φ 12cm × 4 + φ 5cm × 2 (Output 30W + 30W)
Power Requirements	AC Adaptor: AD-E24500LW • Auto Power Off: Approximately 4 hours after last operation. Auto Power Off can be disabled.
Power Consumption	24V --- 28W
Dimensions	Digital Piano and Stand: 137.7 (W) × 42.7 (D) × 91.1 (H) cm (54 1/4 × 16 ¹³ /16 × 35 ⁷ /8 inch)
Weight	Digital Piano and Stand: approximately 48.0kg (105.8 lbs)

- Specifications and designs are subject to change without notice.

Operating Precautions

Be sure to read and observe the following operating precautions.

- With a model that has a recording function or other data storage function, be sure to back up any data you want to maintain to another medium before submitting this product for servicing or repair. Stored data may be accessed or even deleted as part of servicing or repair procedures.

■ Location

Avoid the following locations for this product.

- Areas exposed to direct sunlight and high humidity
- Areas subjected to temperature extremes
- Near a radio, TV, video deck, or tuner
The above devices will not cause malfunction of the product, but the product can cause interference in the audio or video of a nearby device.

■ User Maintenance

- Never use benzine, alcohol, thinner, or other chemical agents to clean the product.
- To clean the product or its keyboard, wipe with a soft cloth moistened in a weak solution of water and a mild neutral detergent. Wring all excess moisture from the cloth before wiping.

■ Included and Optional Accessories

Use only accessories that are specified for use with this product. Use of unauthorized accessories creates the risk of fire, electric shock, and personal injury.

■ Weld Lines

Lines may be visible on the exterior of the product. These are “weld lines” that result from the plastic molding process. They are not cracks or scratches.

■ Musical Instrument Etiquette

Always be aware of others around you whenever using this product. Be especially careful when playing late at night to keep the volume at levels that do not disturb others. Other steps you can take when playing late at night are closing the window and using headphones.

■ AC Adaptor Handling Precautions

- Use a power outlet that is easily accessible so you can unplug the AC adaptor when a malfunction occurs or whenever else you need to do so.
- The AC adaptor is intended for indoor use only. Do not use it where it might be exposed to splashing or moisture. Do not place any container, such as a flower vase, that contains liquid on the AC adaptor.
- Store the AC adaptor in a dry place.
- Use the AC adaptor in an open, well-ventilated area.
- Never cover the AC adaptor with newspaper, a table cloth, a curtain, or any other similar item.
- Unplug the AC adaptor from the power outlet if you do not plan to use the Digital Piano for a long time.
- Never try to repair the AC adaptor or modify it in any way.
- AC adaptor operating environment
Temperature: 0 to 40°C
Humidity: 10% to 90% RH
- Output polarity: 

AC Adaptor Handling Precautions

Model: AD-E24500LW

1. Read these instructions.
2. Keep these instructions on hand.
3. Heed all warnings.
4. Follow all instructions.
5. Do not use this product near water.
6. Clean only with a dry cloth.
7. Do not install near radiators, heat registers, stoves, or any other source of heat (including amplifiers).
8. Use only attachments and accessories specified by the manufacturer.
9. Refer all servicing to qualified service personnel. Servicing is required after any of the following occurs: when the product is damaged, when the power supply cord or plug is damaged, when liquid is spilled into the product, when a foreign object falls into the product, when the product is exposed to rain or moisture, when the product does not operate normally, when the product is dropped.
10. Do not allow the product to be exposed to dripping or splashing liquid. Do not place any object containing liquid on the product.
11. Do not allow the electrical load output to exceed the label rating.
12. Make sure the surrounding area is dry before plugging into a power source.
13. Make sure the product is oriented correctly.
14. Unplug the product during lightning storms or when you do not plan to use it for a long time.
15. Do not allow product ventilation openings to become blocked. Install the product in accordance with the manufacturer's instructions.
16. Take care the power cord is located where it will not be stepped upon or bent severely, particularly in locations close to plugs and convenience receptacles, and in locations where it exits from the product.
17. The AC adaptor should be plugged into a power outlet as close to the product as possible to allow immediate disconnection of the plug in case of emergency.

The symbol below is an alert indicating un-insulated hazardous voltage inside the product's enclosure, which may be sufficient to constitute the risk of electric shock to users.



The symbol below is an alert indicating the presence of important operating and maintenance (servicing) instructions in the documentation that accompanies the product.



Appendix/Apéndice

Tone List/Lista de tonos

Tone Group/ Grupo de tonos	No./N°	Tone Name/ Nombre del tono	Program Change/ Cambio de programa	Bank Select MSB/ MSB de selección de banco
BERLIN GRAND	01	BERLIN GRAND	0	0
	02	BERLIN GRAND MELLOW	0	1
	03	BERLIN GRAND BRIGHT	0	2
	04	HAMBURG GRAND	0	3
HAMBURG GRAND	05	HAMBURG GRAND MELLOW	0	4
	06	HAMBURG GRAND BRIGHT	0	5
VIENNA GRAND	07	VIENNA GRAND	0	6
	08	VIENNA GRAND MELLOW	0	7
	09	VIENNA GRAND BRIGHT	0	8
VARIOUS PIANO	10	GRAND PIANO MODERN	0	9
	11	GRAND PIANO ROCK	0	10
	12	GRAND PIANO JAZZ	0	11
ELECTRIC PIANO	13	ELECTRIC PIANO 1	4	0
	14	ELECTRIC PIANO 2	4	1
	15	FM E.PIANO	5	0
	16	60'S E.PIANO	4	2
HARPSL./ VIB.	17	HARPSICHORD	6	0
	18	VIBRAPHONE	11	0
STRINGS	19	STRINGS 1	49	0
	20	STRINGS 2	48	0
ORGAN	21	PIPE ORGAN	19	0
	22	JAZZ ORGAN	17	0
	23	ELECTRIC ORGAN 1	16	0
	24	ELECTRIC ORGAN 2	16	1
BASS	25	ACOUSTIC BASS	32	0
	26	RIDE BASS	32	1

NOTE

- Each of the grand piano tones has its own distinctive characteristics. Each tone has its own distinctive merits, so you should select the tone that suits the song you are playing along with or your own personal preferences.

Tone name	Description
BERLIN GRAND	A well-contoured, light, chic, and elegant tone. Superior clarity and reverberation play of richly colored, beautiful melodies. This tone is best for performance of impressionistic period music.
MELLOW	Slightly more subdued BERLIN GRAND tone.
BRIGHT	Slightly brighter BERLIN GRAND tone.
HAMBURG GRAND	A widely expressive, richly reverberating tone with force and power that sounds great even in the expanse of a concert hall. This tone is the favorite choice of concert pianists around the globe. This tone is suitable for virtually any type of performance and musical genre.
MELLOW	Slightly more subdued HAMBURG GRAND tone.
BRIGHT	Slightly brighter HAMBURG GRAND tone.
VIENNA GRAND	A tone that combines powerful low range strings and a beautifully light touch for a broad range of expressivity, and richly majestic sound. This tone is best for performance of classical period music.
MELLOW	Slightly more subdued VIENNA GRAND tone.
BRIGHT	Slightly brighter VIENNA GRAND tone.
GRAND PIANO MODERN	A bright grand piano tone is a good choice for dynamic and lively performances.
GRAND PIANO ROCK	A grand piano tone with bright reverberation and strong attack. Suitable for rock music.
GRAND PIANO JAZZ	A grand piano tone with reverberation and sound suitable for jazz music.

NOTA

- Cada uno de los tonos de piano de cola tiene sus características propias que los distinguen. Cada uno se caracteriza por un valor expresivo propio, de manera que es importante seleccionar el tono que mejor se adapte a la canción que está acompañando o a sus preferencias personales.

Nombre del tono	Descripción
BERLIN GRAND	Tono claramente definido, nítido, exquisito y elegante. Reproducción de hermosas melodías ricas en matices con una superior claridad y efectos de reverberación. Este tono es ideal para interpretar música de la época impresionista.
MELLOW	Tono BERLIN GRAND algo más atenuado.
BRIGHT	Tono BERLIN GRAND algo más brillante.
HAMBURG GRAND	Con una amplia gama expresiva y rica reverberación, el potente y fuerte sonido llena incluso el ambiente de una sala de concierto. Este es el tono preferido por los pianistas de concierto de todo el mundo. Asimismo, es el tono adecuado para prácticamente cualquier tipo de interpretación y género musical.
MELLOW	Tono HAMBURG GRAND algo más atenuado.
BRIGHT	Tono HAMBURG GRAND algo más brillante.
VIENNA GRAND	Un tono que combina potentes cuerdas de rango bajo con un toque perfectamente suave para una amplia gama de expresividad y un sonido exquisitamente sofisticado. Es el tono perfecto para interpretar música de la época clásica.
MELLOW	Tono VIENNA GRAND algo más atenuado.
BRIGHT	Tono VIENNA GRAND algo más brillante.
GRAND PIANO MODERN	El brillante tono de piano de cola es la elección ideal para actuaciones dinámicas, animadas.
GRAND PIANO ROCK	Tono de piano de cola con reverberación brillante y ataque intenso. Adecuado para música rock.
GRAND PIANO JAZZ	Tono de piano de cola con reverberación y un sonido adecuado para música jazz.

Concert Play List/ Lista de Interpretaciones de concierto

No./N°	Song Name/Nombre de la canción
1	Piano Concerto No.1 Op.23 1st Mov.
2	Prelude Op.28-15 "Raindrop"
3	Symphony No.9 "An Die Freude"
4	Je Te Veux
5	Vltava (Má vlast)
6	Canon
7	Sonate Op.13 "Pathétique" 2nd Mov.
8	Chanson Triste
9	Jesus, Bleibet Meine Freude
10	Tableaux d'Une Exposition "Promenade"
11	Sonate K.331 1st Mov.
12	Polovetzian Dance (Prince Igor)
13	Piano Concerto No.20 K.466 2nd Mov.
14	Violin Concerto Op.64 1st Mov.
15	Melody In F

Music Library List/ Lista de la biblioteca musical

No./N°	Song Name/Nombre de la canción
1	Nocturne Op.9-2
2	Fantaisie-Impromptu Op.66
3	Étude Op.10-3 "Chanson de l'adieu"
4	Étude Op.10-5 "Black Keys"
5	Étude Op.10-12 "Revolutionary"
6	Étude Op.25-9 "Butterflies"
7	Prélude Op.28-7
8	Valse Op.64-1 "Petit Chien"
9	Valse Op.64-2
10	Moments Musicaux 3
11	Impromptu Op.90-2
12	Marche Militaire 1 (Duet)
13	Frühlingslied [Lieder Ohne Worte Heft 5]
14	Fröhlicher Landmann [Album für die Jugend]
15	Von fremden Ländern und Menschen [Kinderszenen]
16	Träumerei [Kinderszenen]
17	Tambourin
18	Menuet BWV Anh.114 [Clavierbüchlein der Anna Magdalena Bach]
19	Inventio 1 BWV 772
20	Inventio 8 BWV 779
21	Inventio 13 BWV 784
22	Praeludium 1 BWV 846 [Das Wohltemperierte Klavier 1]
23	Le Coucou
24	Gavotte
25	Sonatina Op.36-1 1st Mov.
26	Sonatine Op.20-1 1st Mov.
27	Sonate K.545 1st Mov.
28	Sonate K.331 3rd Mov. "Turkish March"
29	Rondo K.485
30	Für Elise
31	Marcia alla Turca
32	Sonate Op.13 "Pathétique" 1st Mov.
33	Sonate Op.13 "Pathétique" 2nd Mov.
34	Sonate Op.13 "Pathétique" 3rd Mov.
35	Sonate Op.27-2 "Moonlight" 1st Mov.
36	Rhapsodie 2
37	Waltz Op.39-15 (Duet)
38	Liebesträume 3
39	Blumenlied
40	La Prière d'une Vierge
41	Csikos Post
42	Humoresque Op.101-7
43	Melodie [Lyrische Stücke Heft 2]
44	Sicilienne Op.78
45	Berceuse [Dolly] (Duet)
46	Arabesque 1
47	La Fille aux Cheveux de Lin [Préludes]
48	Passepied [Suite bergamasque]
49	Gymnopédie 1
50	Je Te Veux
51	Salut d'Amour
52	The Entertainer
53	Maple Leaf Rag
54	L'arabesque [25 Étüden Op.100]
55	La Styrienne [25 Étüden Op.100]
56	Ave Maria [25 Étüden Op.100]
57	Le retour [25 Étüden Op.100]
58	La chevaleresque [25 Étüden Op.100]
59	No.13 [Études de Mécanisme Op.849]
60	No.26 [Études de Mécanisme Op.849]

Grand Piano Demo Song List/ Lista de canciones de demostración del piano de cola

- The length of a Grand Piano demo song built into this Digital Piano may be different from the length of the original pieces it is based upon.
- La duración de las canciones de demostración del piano de cola incluidas en este piano digital puede diferir de la duración de las piezas originales sobre las que se basan.

Tone Name/ Nombre del tono	Display Text/ Texto visualizado	Song Name/Nombre de la canción
BERLIN GRAND	Berlin 1	Les jeux d'eaux à la Villa d'Este [Années de pèlerinage Troisième année S.163]
BERLIN GRAND	Berlin 2	Arabesque 2
HAMBURG GRAND	Hamburg 1	Polonaise Op.53 "Héroïque"
HAMBURG GRAND	Hamburg 2	Valse=Ballet
VIENNA GRAND	Vienna 1	Sonate Op.53 "Waldstein" 1st Mov.
VIENNA GRAND	Vienna 2	Intermezzo A-dur [6 Klavierstücke Op.118]

MIDI Implementation Chart

Function	Transmitted	Recognized	Remarks
Basic Channel Default Changed	1 - 16 1 - 16	1 - 16 1 - 16	
Mode Default Messages Altered	Mode 3 X * * * * * * * * * *	Mode 3 X * * * * * * * * * *	
Note Number True voice	0 - 127 * * * * * * * * * *	0 - 127 0 - 127*1	*1 : Depends on tone *1 : Depende del tono
Velocity Note ON Note OFF	0 9nH v = 1 - 127 0 8nH v = 0 - 127	0 9nH v = 1 - 127 X 9nH v = 0, O 8nH v = 0 - 127	
After Touch Key's Ch's	X X	X O	
Pitch Bender	X	O	
Control Change	0, 32 1 5 6, 37 10 11 16 17 18 19 64 65 66 67	O X X X X X X X X X X X X X X X X X X O	Bank select Modulation Portamento Time Portamento Sensitivity LSB, MSB*2 Volume Pan Expression DSP Parameter*2 DSP Parameter*2 DSP Parameter*2 DSP Parameter*2 Damp Portamento Switch Sostenuto Soft pedal

76	X			
77	X			
78	X			
80	X			
81	X			
82	X			
83	X			
84	X			
85	X			
86	X			
87	X			
88	X			
89	X			
90	X			
91	X			
92	X			
93	X			
94	X			
95	X			
96	X			
97	X			
98	X			
99	X			
100	X			
101	X			
102	X			
103	X			
104	X			
105	X			
106	X			
107	X			
108	X			
109	X			
110	X			
111	X			
112	X			
113	X			
114	X			
115	X			
116	X			
117	X			
118	X			
119	X			
120	X			
121	X			
	Program Change	: True #		
	System Exclusive			
	System Common	: Song Pos : Song Sel : Tune		
	System Real Time	: Clock : Commands		
	Aux Messages	: Local ON/OFF : All notes OFF : Active Sense : Reset		
	Remarks			

Vibrato rate
Vibrato depth
Vibrato delay
Vibrato filter*2
DSP Parameter1*2
DSP Parameter2*2
DSP Parameter6*2
DSP Parameter7*2
Portamento Control
High speed velocity prefix
Right hand*3
Chorus send
RPN LSB, MSB*2
All sound off
Reset all controller

0-127

*2

*2: For details, see MIDI Implementation at <http://world.casio.com/>.

*3: This Instrument treats a hall simulator as a reverb.

*2: Si desea más información, vea Implementación MIDI en <http://world.casio.com/>.

*3: Este instrumento considera al simulador de salas como una reverberación.

Mode 1 : OMNI ON, POLY
Mode 3 : OMNI OFF, POLY

Mode 2 : OMNI ON, MONO
Mode 4 : OMNI OFF, MONO

O : Yes
X : No



This recycle mark indicates that the packaging conforms to the environmental protection legislation in Germany.

Esta marca de reciclaje indica que el empaquetado se ajusta a la legislación de protección ambiental en Alemania.

CASIO®

