

DLP® Projector

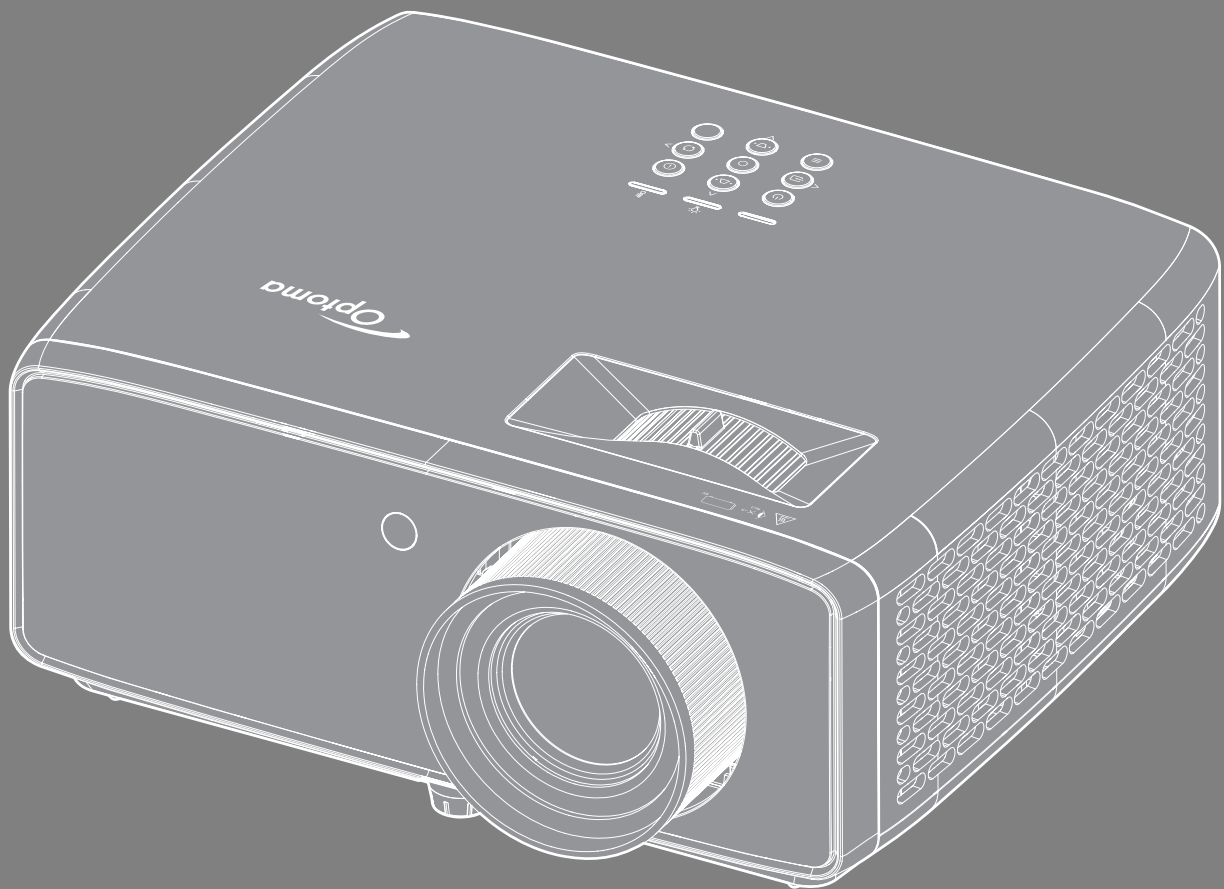

TABLE OF CONTENTS



| | |
|---|-----------|
| SAFETY | 4 |
| <i>Important Safety Instruction</i> | 4 |
| <i>Laser Radiation Safety Information</i> | 5 |
| <i>Laser Notice</i> | 6 |
| <i>Copyright</i> | 6 |
| <i>Disclaimer</i> | 6 |
| <i>Trademark Recognition</i> | 6 |
| <i>FCC</i> | 7 |
| <i>Declaration of Conformity for EU countries</i> | 7 |
| <i>WEEE</i> | 7 |
| <i>CTUVUS</i> | 7 |
| <i>Specifications and Warning labels</i> | 8 |
| <i>Cleaning the Lens</i> | 8 |
| | |
| INTRODUCTION | 10 |
| <i>Package Overview</i> | 10 |
| <i>Standard accessories</i> | 10 |
| <i>Product Overview</i> | 11 |
| <i>Connections</i> | 12 |
| <i>Keypad</i> | 13 |
| <i>Remote control</i> | 14 |
| | |
| SETUP AND INSTALLATION | 15 |
| <i>Installing the projector</i> | 15 |
| <i>Connecting sources to the projector</i> | 17 |
| <i>Adjusting the projector image</i> | 18 |
| <i>Remote setup</i> | 19 |
| | |
| USING THE PROJECTOR | 21 |
| <i>Powering on / off the projector</i> | 21 |
| <i>Selecting an input source</i> | 24 |
| <i>Menu navigation and features</i> | 25 |
| <i>OSD Menu tree</i> | 26 |
| <i>Image picture mode menu</i> | 30 |
| <i>Image dynamic range menu</i> | 30 |
| <i>Image brightness menu</i> | 30 |
| <i>Image contrast menu</i> | 30 |
| <i>Image sharpness menu</i> | 31 |
| <i>Image gamma menu</i> | 31 |
| <i>Image brightness mode menu</i> | 31 |
| <i>Image PureEngine menu</i> | 31 |
| <i>Image color settings menu</i> | 31 |
| <i>Image reset menu</i> | 32 |

| | |
|--|----|
| <i>Display aspect ratio menu</i> | 33 |
| <i>Display geometric correction menu</i> | 34 |
| <i>Display reset menu</i> | 34 |
| <i>Setup test pattern menu</i> | 35 |
| <i>Setup projection orientation menu</i> | 35 |
| <i>Setup language menu</i> | 35 |
| <i>Setup high altitude menu</i> | 35 |
| <i>Setup power settings menu</i> | 35 |
| <i>Setup auto source menu</i> | 35 |
| <i>Setup HDMI CEC settings menu</i> | 36 |
| <i>Setup background color menu</i> | 36 |
| <i>Setup keypad settings menu</i> | 36 |
| <i>Setup remote settings menu</i> | 37 |
| <i>Setup device ID menu</i> | 37 |
| <i>Setup USB system update menu</i> | 37 |
| <i>Setup device reset menu</i> | 37 |
| <i>Audio volume menu</i> | 38 |
| <i>Audio mute menu</i> | 38 |
| <i>Audio audio output menu</i> | 38 |
| <i>Audio audio output settings menu</i> | 38 |
| <i>Audio reset menu</i> | 38 |
| <i>Information menu</i> | 39 |

ADDITIONAL INFORMATION..... 40

| | |
|--|----|
| <i>Compatible resolutions</i> | 40 |
| <i>Image size and projection distance</i> | 42 |
| <i>Projector dimensions and ceiling mount installation</i> | 43 |
| <i>IR remote control codes</i> | 45 |
| <i>Troubleshooting</i> | 47 |
| <i>Warning indicators</i> | 49 |
| <i>Specifications</i> | 50 |
| <i>Optoma global offices</i> | 51 |

SAFETY

| | |
|---|---|
|  | The lightning flash with arrow head within an equilateral triangle is intended to alert the user to the presence of uninsulated "dangerous voltage" within the product's enclosure that may be of sufficient magnitude to constitute a risk of electric shock to persons. |
|  | The exclamation point within an equilateral triangle is intended to alert the user to the presence of important operating and maintenance (servicing) instructions in the literature accompanying the appliance. |

Please follow all warnings, precautions and maintenance as recommended in this user's guide.

Important Safety Instruction

- Do not block any ventilation openings. To ensure reliable operation of the projector and to protect from over heating, it is recommended to install the projector in a location that does not block ventilation. As an example, do not place the projector on a crowded coffee table, sofa, bed, etc. Do not put the projector in an enclosure such as a book case or a cabinet that restricts air flow.
- To reduce the risk of fire and/or electric shock, do not expose the projector to rain or moisture. Do not install near heat sources such as radiators, heaters, stoves or any other apparatus such as amplifiers that emits heat.
- Do not let objects or liquids enter the projector. They may touch dangerous voltage points and short out parts that could result in fire or electric shock.
- Do not use under the following conditions:
 - In extremely hot, cold or humid environments.
 - (i) Ensure that the ambient room temperature is within 0°C ~ 40°C
 - (ii) Relative humidity is up to 80%
 - In areas susceptible to excessive dust and dirt.
 - Near any appliance generating a strong magnetic field.
 - In direct sunlight.
- Do not use the unit if it has been physically damaged or abused. Physical damage/abuse would be (but not limited to):
 - Unit has been dropped.
 - Power supply cord or plug has been damaged.
 - Liquid has been spilled on to the projector.
 - Projector has been exposed to rain or moisture.
 - Something has fallen in the projector or something is loose inside.
- Do not place the projector on an unstable surface. The projector may fall over resulting in injury or the projector may become damaged.
- Do not block the light coming out of the projector lens when in operation. The light will heat the object and may melt, cause burns or start a fire.
- Please do not open or disassemble the projector as this may cause electric shock.
- Do not attempt to service the unit yourself. Opening or removing covers may expose you to dangerous voltages or other hazards. Please call Optoma before you send the unit for repair.
- See projector enclosure for safety related markings.
- The unit should only be repaired by authorized service personnel.
- Only use attachments/accessories specified by the manufacturer.
- Do not look straight into the projector lens during operation. The bright light may harm your eyes.
- This projector will detect the life of the light source itself.

- When switching the projector off, please ensure the cooling cycle has been completed before disconnecting power. Allow 90 seconds for the projector to cool down.
- Turn off and unplug the power plug from the AC outlet before cleaning the product.
- Use a soft dry cloth with mild detergent to clean the display housing. Do not use abrasive cleaners, waxes or solvents to clean the unit.
- Disconnect the power plug from AC outlet if the product is not being used for a long period of time.
- Do not setup the projector in places where it might be subjected to vibration or shock.
- Do not touch the lens with bare hands.
- Remove battery/batteries from remote control before storage. If the battery/batteries are left in the remote for long periods, they may leak.
- Do not use or store the projector in places where smoke from oil or cigarettes may be present, as it can adversely affect the quality of the projector performance.
- Please follow the correct projector orientation installation as non standard installation may affect the projector performance.
- Use a power strip and/or surge protector. As power outages and brown-outs can KILL devices.

Laser Radiation Safety Information

- This product is classified as CLASS 1 LASER PRODUCT - RISK GROUP 2 of IEC60825-1 : 2014 and also complies with 21 CFR 1040.10 and 1040.11 as a Risk Group 2, LIP (Laser Illuminated Projector) as defined in IEC 62471-5:Ed. 1.0. For more information see Laser Notice No. 57, dated May 8, 2019.
- Complies with 21 CFR 1040.10 and 1040.11 except for conformance as a Risk Group 2 LIP as defined in IEC 62471-5:Ed. 1.0. For more information see Laser Notice No. 57, dated May 8, 2019.
- IEC 60825-1:2014/EN 60825-1+A11/EN50689:2021 CLASS 1 CONSUMER LASER PRODUCT RISK GROUP 2
- IEC 62471-5:2015 RISK GROUP 2

IEC 60825-1:2014, EN 60825-1:2014+A11:2021, EN 50689:2021 CLASS 1 CONSUMER LASER PRODUCT RISK GROUP 2, Complies with 21 CFR 1040.10 and 1040.11 except for conformance as a Risk Group 2 LIP as defined in IEC 62471-5:Ed.1.0. For more information see Laser Notice No. 57, dated May 8, 2019.
 IEC 60825-1:2014 等級1雷射產品RG2危險等級
 IEC 60825-1:2014 1類激光產品RG2危險等級

WARNING: MOUNT ABOVE THE HEADS OF CHILDREN!
 Do not look into the beam less than 1m.
 No direct eye exposure to the beam is permitted.
 "AVERTISSEMENT:INSTALLER AU-DESSUS DE LA TETE DES ENFANTS."
 Avertissement supplémentaire contre l'exposition oculaire pour des expositions à une distance de moins de 1m.
 「警告：安裝高於兒童頭頂！」
 請勿在距離小於1米的範圍內直視光束。嚴禁眼睛直接暴露於光束中。
 「警告：安裝高於兒童頭頂！」
 請勿在距離小於1米的範圍內直視光束。嚴禁眼睛直接暴露於光束中。

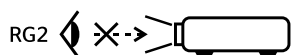

- Additional instructions to supervise children, no staring, and not use optical aids.
- Additional instructions to install above the reach of children.
- Notice is given to supervise children and to never allow them to stare into the projector beam at any distance from the projector.
- Notice is given to use caution when using the remote control for starting the projector while in front of the projection lens.
- Notice is given to the user to avoid the use of optical aids such as binoculars or telescopes inside the beam.
- As with any bright source, do not stare into the direct beam, RG2 IEC 62471-5:2015.
- **WARNING: MOUNT ABOVE THE HEADS OF CHILDREN.** The use of a ceiling mount is recommended with this product to place it above the eyes of children.

- Caution - use of controls or adjustments or performance of procedures other than those specified herein may result in hazardous radiation exposure.
- Do not open or disassemble the projector as this may cause damage by the exposure of laser radiation.
- Do not stare into beam when the projector is on. The bright light may result in permanent eye damage.

Not following the control, adjustment or operation procedure may cause damage by the exposure of laser radiation.

Laser Notice

IEC 60825-1:2014/EN 60825-1+A11/EN50689:2021 CLASS 1 CONSUMER LASER PRODUCT RISK GROUP 2.

The product's intended use as a consumer laser product and compliant with EN 50689:2021.

CLASS 1 CONSUMER LASER PRODUCT

EN 50689:2021

Copyright

This publication, including all photographs, illustrations and software, is protected under international copyright laws, with all rights reserved. Neither this manual, nor any of the material contained herein, may be reproduced without written consent of the author.

© Copyright 2025

Disclaimer

The information in this document is subject to change without notice. The manufacturer makes no representations or warranties with respect to the contents hereof and specifically disclaims any implied warranties of merchantability or fitness for any particular purpose. The manufacturer reserves the right to revise this publication and to make changes from time to time in the content hereof without obligation of the manufacturer to notify any person of such revision or changes.

Trademark Recognition

Kensington is a U.S. registered trademark of ACCO Brand Corporation with issued registrations and pending applications in other countries throughout the world.

HDMI, the HDMI Logo, and High-Definition Multimedia Interface are trademarks or registered trademarks of HDMI Licensing LLC in the United States and other countries.

DLP®, DLP Link and the DLP logo are registered trademarks of Texas Instruments and BrilliantColor™ is a trademark of Texas Instruments.

FILMMAKER MODE™ logo is a trademark of UHD Alliance, Inc.

All other product names used in this manual are the properties of their respective owners and are Acknowledged.

FCC

This device has been tested and found to comply with the limits for a Class B digital device pursuant to Part 15 of the FCC rules. These limits are designed to provide reasonable protection against harmful interference in a residential installation. This device generates, uses and can radiate radio frequency energy and, if not installed and used in accordance with the instructions, may cause harmful interference to radio communications.

However, there is no guarantee that interference will not occur in a particular installation. If this device does cause harmful interference to radio or television reception, which can be determined by turning the device off and on is encouraged to try to correct the interference by one or more of the following measures:

- Reorient or relocate the receiving antenna.
- Increase the separation between the device and receiver.
- Connect the device into an outlet on a circuit different from that to which the receiver is connected.
- Consult the dealer or an experienced radio/television technician for help.

Notice: Shielded cables

All connections to other computing devices must be made using shielded cables to maintain compliance with FCC regulations.

Caution

Changes or modifications not expressly approved by the manufacturer could void the user's authority, which is granted by the Federal Communications Commission, to operate this projector.

Operation Conditions

This device complies with Part 15 of the FCC Rules. Operation is subject to the following two conditions:

1. This device may not cause harmful interference and
2. This device must accept any interference received, including interference that may cause undesired operation.

Notice: Canadian users

This Class B digital apparatus complies with Canadian ICES-003.

Remarque à l'intention des utilisateurs canadiens

Cet appareil numérique de la classe B est conforme à la norme NMB-003 du Canada.

Declaration of Conformity for EU countries

- EMC Directive 2014/30/EU (including amendments)
- Low Voltage Directive 2014/35/EU
- RED 2014/53/EU (if product has RF function)

WEEE



Disposal instructions

Do not throw this electronic device into the trash when discarding. To minimize pollution and ensure utmost protection of the global environment, please recycle it.

CTUVUS

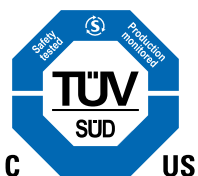

Specifications and Warning labels

Specifications and Warning labels are placed at the following location:

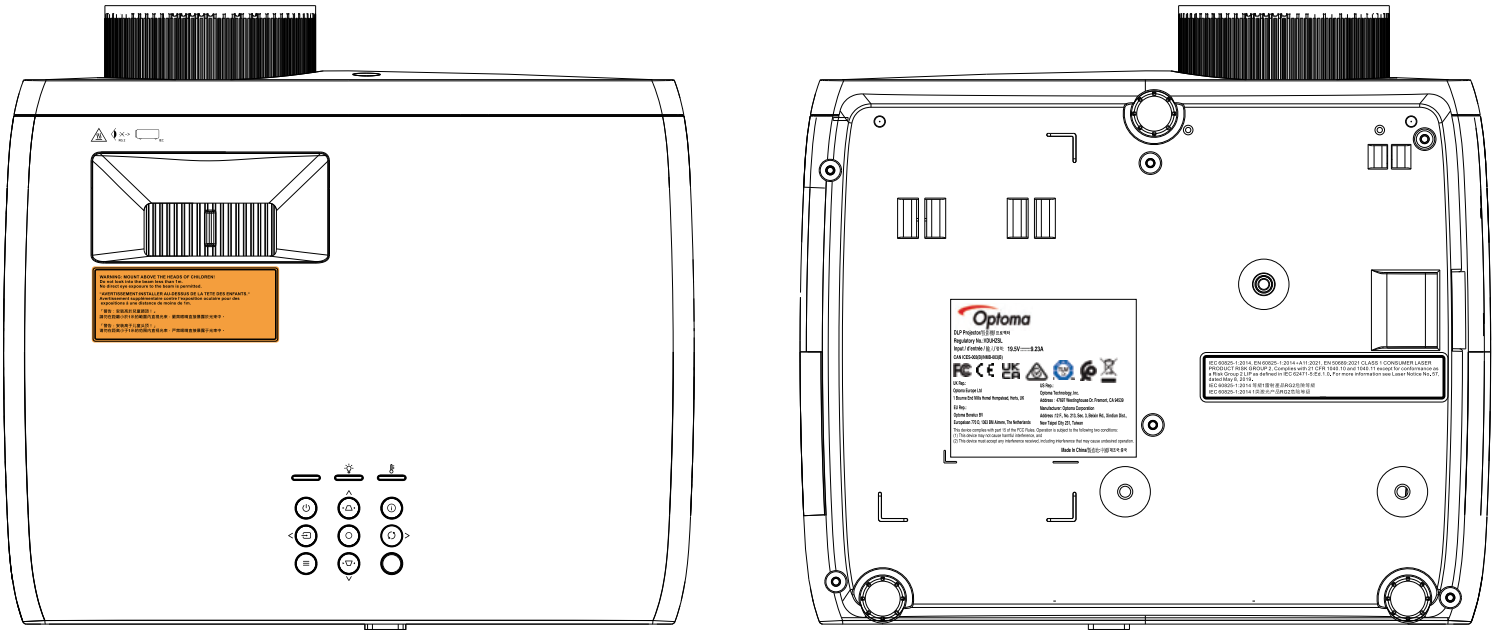

Note: For power supply, power ratings, and product information, please refer to the label on the bottom of the product.

Cleaning the Lens

- Before cleaning the lens, be sure to turn off the projector and unplug the power cord to allow it to completely cool down.
- Use a compressed air tank to remove the dust.
- Use a special cloth for cleaning lens and gently wipe the lens. Do not touch the lens with your fingers.
- Do not use alkaline/acid detergents or volatile solvents such as alcohol for cleaning lens. If the lens is damaged due to the cleaning process, it is not covered by the warranty.

CAUTION! Hot surface, Do not touch



- Do not place your hands, face, or other objects in front of the projector lens while the projector is operating. Doing so can cause the object to get extremely hot, and possibly resulting in a fire or damage due to the heat emitted from the light output. Things placed in front of the lens may overheat and burn or start a fire.
- Do not spray flammable gas to get rid of dust and dirt that accumulate in the lens. Doing so could cause a fire.



Warning: Do not use a spray containing flammable gases to remove dust or dirt from the lens. This may cause a fire due to excessive heat inside the projector.



Warning: Do not clean the lens if the projector is warming up as this may cause the lens' surface film to peel off.



Warning: Do not wipe or tap the lens with a hard object.

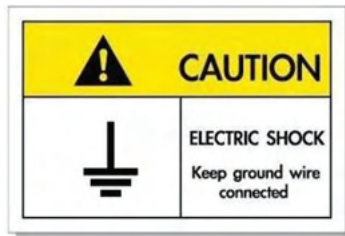

- To avoid electric shock, the unit and its peripherals must be properly grounded (earthed).
- This equipment is equipped with a three-pin grounding-type power plug.
- Do not remove the grounding pin on the power plug.
- This is a safety feature. If you are unable to insert the plug into the outlet, contact an electrician.
- Do not defeat the purpose of the grounding plug.

INTRODUCTION

Thank you for purchasing an Optoma laser projector. For full list of features please visit the product page on our website, where you will also find additional information and documentation such as FAQs.

Package Overview

Carefully unpack and verify that you have the items listed below under standard accessories. Some of the items under optional accessories may not be available depending on the model, specification and your region of purchase. Please check with your place of purchase. Some accessories may vary from region to region.

The warranty card is only supplied in some specific regions. Please consult your dealer for detailed information.

Standard accessories

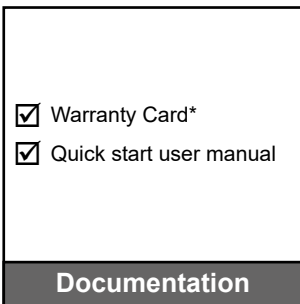
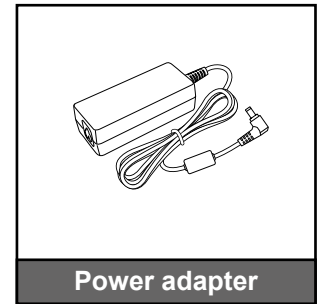
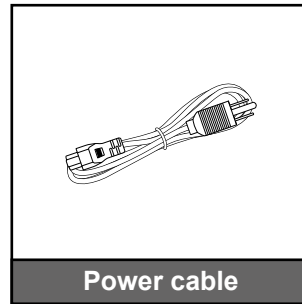
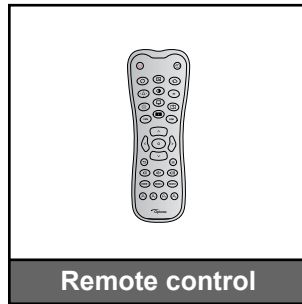
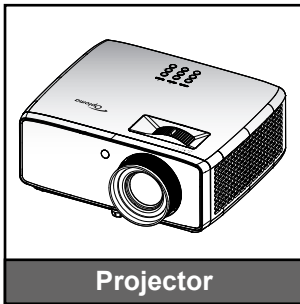

Note:

- *The remote control is shipped with batteries.*
- **For warranty Information, please visit <https://www.optoma.com/support/download>*
- *For access to the setup information, user manual, warranty information, and product updates – please scan the QR Code or visit the following URL:
<https://www.optoma.com/support/download>*



INTRODUCTION

Product Overview

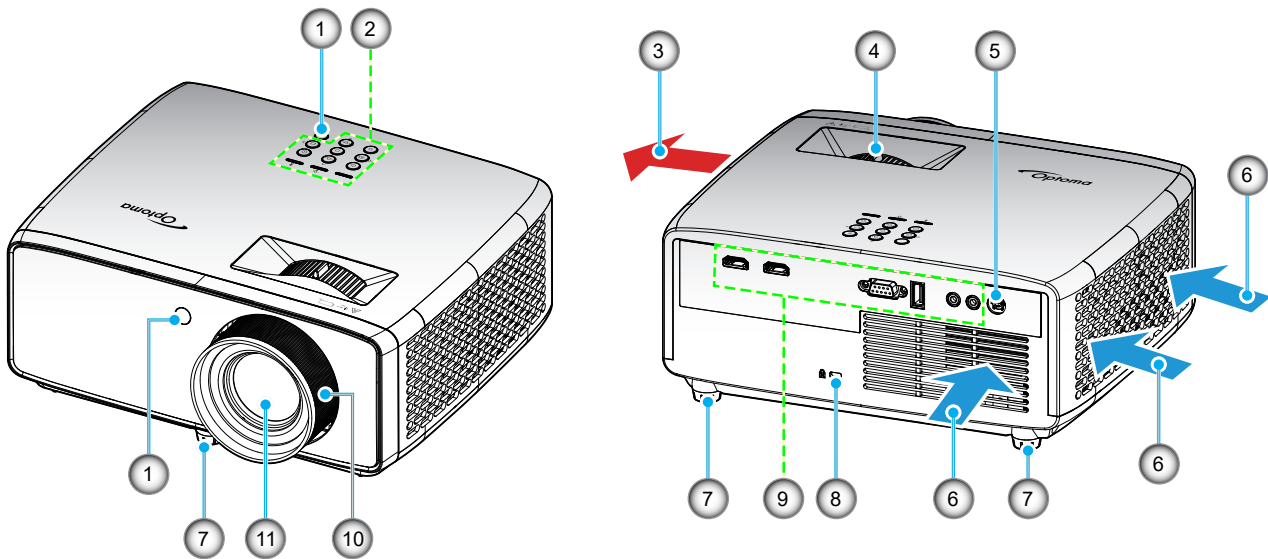

Note:

- Do not block projector intake and exhaust vents.
- When operating the projector in an enclosed space, allow at least 30 cm clearance around the intake and exhaust vents.

| No | Item | No | Item |
|----|----------------------|-----|-----------------------|
| 1. | IR Receivers | 7. | Tilt-Adjustment Feet |
| 2. | Keypad | 8. | Kensington™ Lock Port |
| 3. | Ventilation (outlet) | 9. | Input / Output |
| 4. | Zoom Lever | 10. | Focus Ring |
| 5. | DC Jack | 11. | Lens |
| 6. | Ventilation (inlet) | | |

INTRODUCTION

Connections

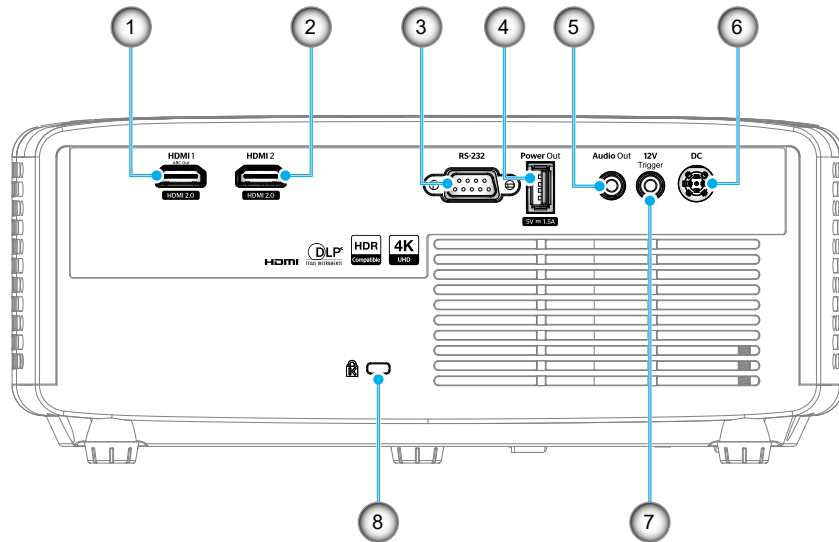

| No | Item | No | Item |
|----|-------------------------------------|----|-----------------------|
| 1. | HDMI 1 (ARC Out) Connector | 5. | Audio Out Connector |
| 2. | HDMI 2 Connector | 6. | DC Jack |
| 3. | RS-232 Connector | 7. | 12V OUT Connector |
| 4. | USB Power Out (5V---1.5A) Connector | 8. | Kensington™ Lock Port |

Note: Signal mode support varies from different model in each sales region.

INTRODUCTION

Keypad

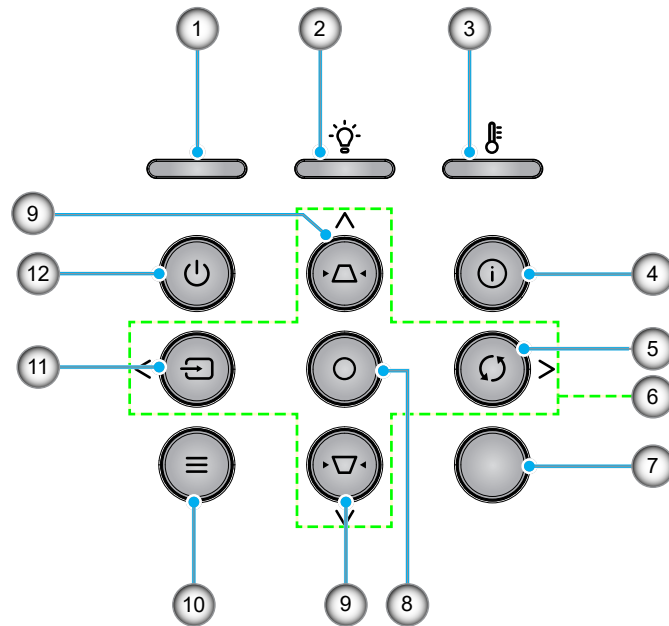

| No | Item | No | Item |
|----|------------------------------|-----|---------------------|
| 1. | Power LED | 7. | IR Receiver |
| 2. | Lamp LED | 8. | Enter |
| 3. | Temp LED | 9. | Keystone Correction |
| 4. | Information | 10. | Menu |
| 5. | Re-Sync | 11. | Source |
| 6. | Four Directional Select Keys | 12. | Power |

INTRODUCTION

Remote control

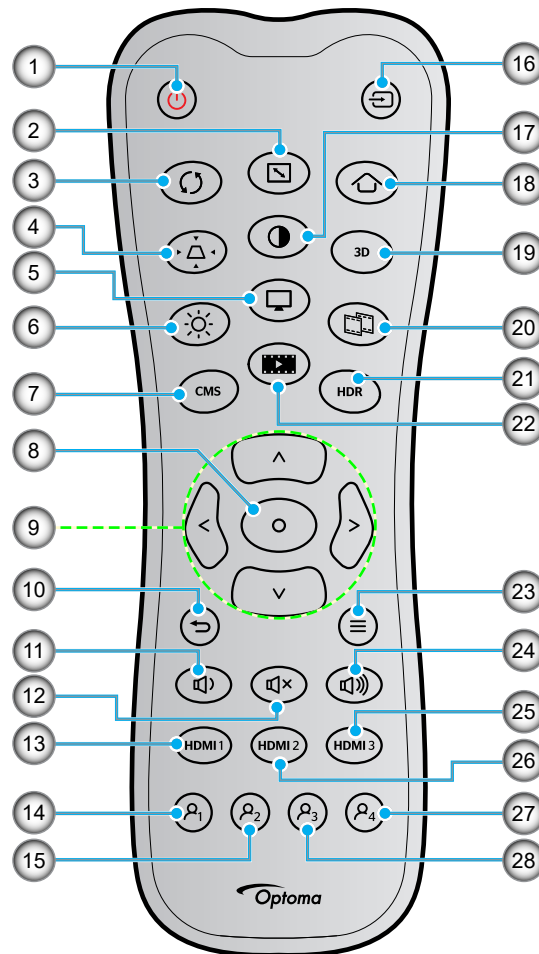

| No | Item | No | Item |
|-----|------------------------------|-----|----------------------------------|
| 1. | Power On | 15. | User2 (assignable) |
| 2. | Aspect Ratio | 16. | Source |
| 3. | Re-sync | 17. | Contrast |
| 4. | Keystone | 18. | Home (not supported) |
| 5. | Mode | 19. | 3D Menu On / Off (not supported) |
| 6. | Brightness | 20. | Low Latency Mode (not supported) |
| 7. | CMS | 21. | HDR |
| 8. | Enter | 22. | FILMMAKER MODE |
| 9. | Four Directional Select Keys | 23. | Menu |
| 10. | Return | 24. | Vol + |
| 11. | Vol - | 25. | HDMI3 (not supported) |
| 12. | Mute | 26. | HDMI2 |
| 13. | HDMI1 | 27. | User4 (assignable) |
| 14. | User1 (assignable) | 28. | User3 (assignable) |

Note:

- The actual remote control may vary depending on the region.
- Some keys may have no function for models that do not support these features.

SETUP AND INSTALLATION

Installing the projector

Your projector is designed to be installed in one of four possible positions.

Your room layout or personal preference will dictate which installation location you select. Take into consideration the size and position of your screen, the location of a suitable power outlet, as well as the location and distance between the projector and the rest of your equipment.

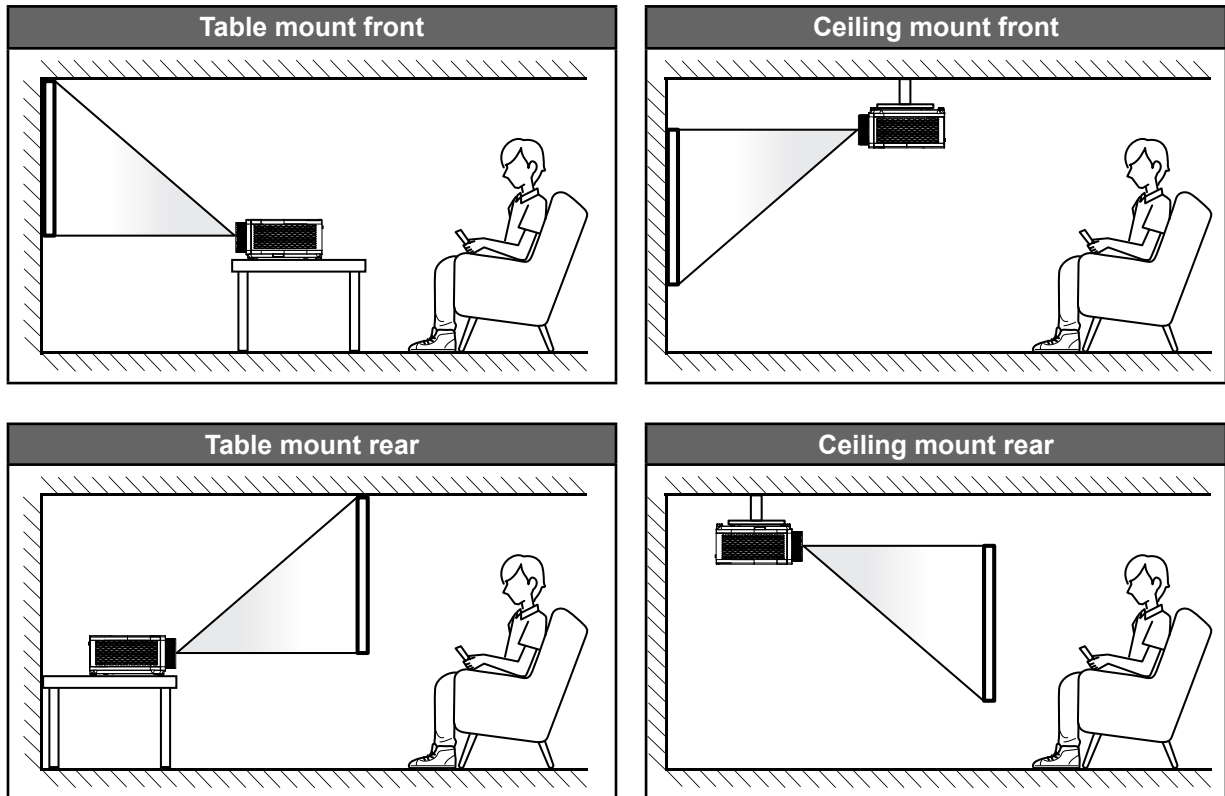

Projector should be placed flat on a surface and 90 degrees / perpendicular to the screen.

- How to determine projector location for a given screen size, please refer to distance table on page 42.
- How to determine screen size for a given distance, please refer to distance table on page 42.

Note: *The further away the projector is placed from the screen the projected image size increases and vertical offset also increases proportionally.*

SETUP AND INSTALLATION

Projector installation notice

- 360° free orientation operation

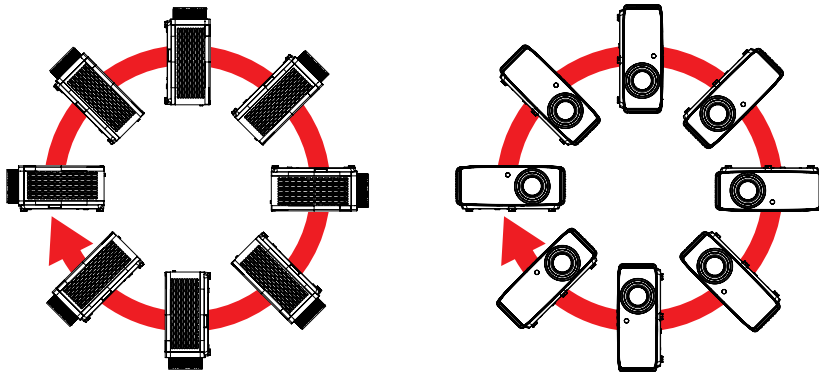

- Allow at least 30 cm clearance around the exhaust vent.

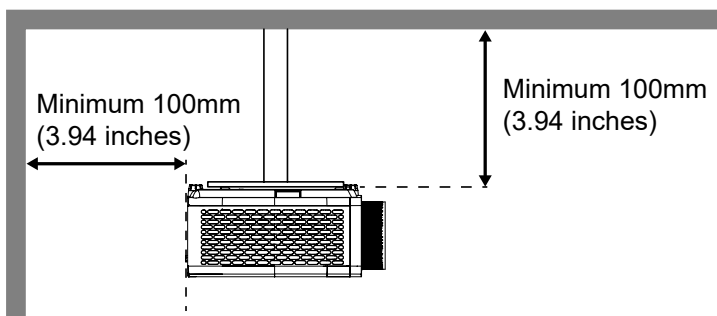
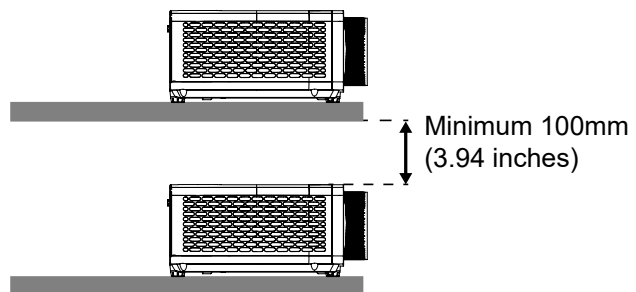
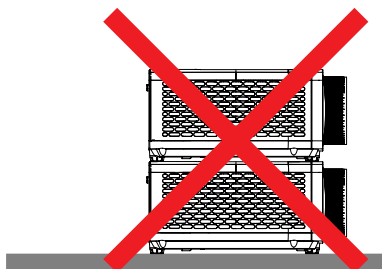
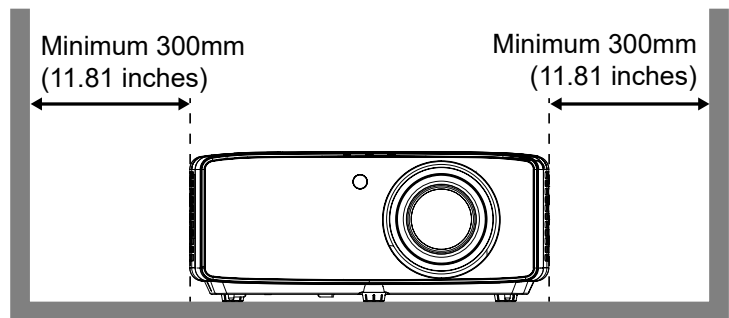
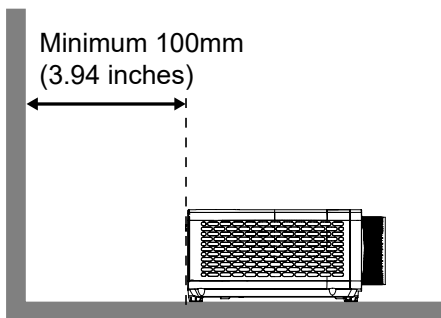

- Ensure that the intake vents do not recycle hot air from the exhaust vent.
- When operating the projector in an enclosed space, ensure that the surrounding air temperature within the enclosure does not exceed operation temperature while the projector is running, and the air intake and exhaust vents are unobstructed.
- All enclosures should pass a certified thermal evaluation to ensure that the projector does not recycle exhaust air, as this may cause the device to shutdown even if the enclosure temperature is within the acceptable operation temperature range.

SETUP AND INSTALLATION

Connecting sources to the projector

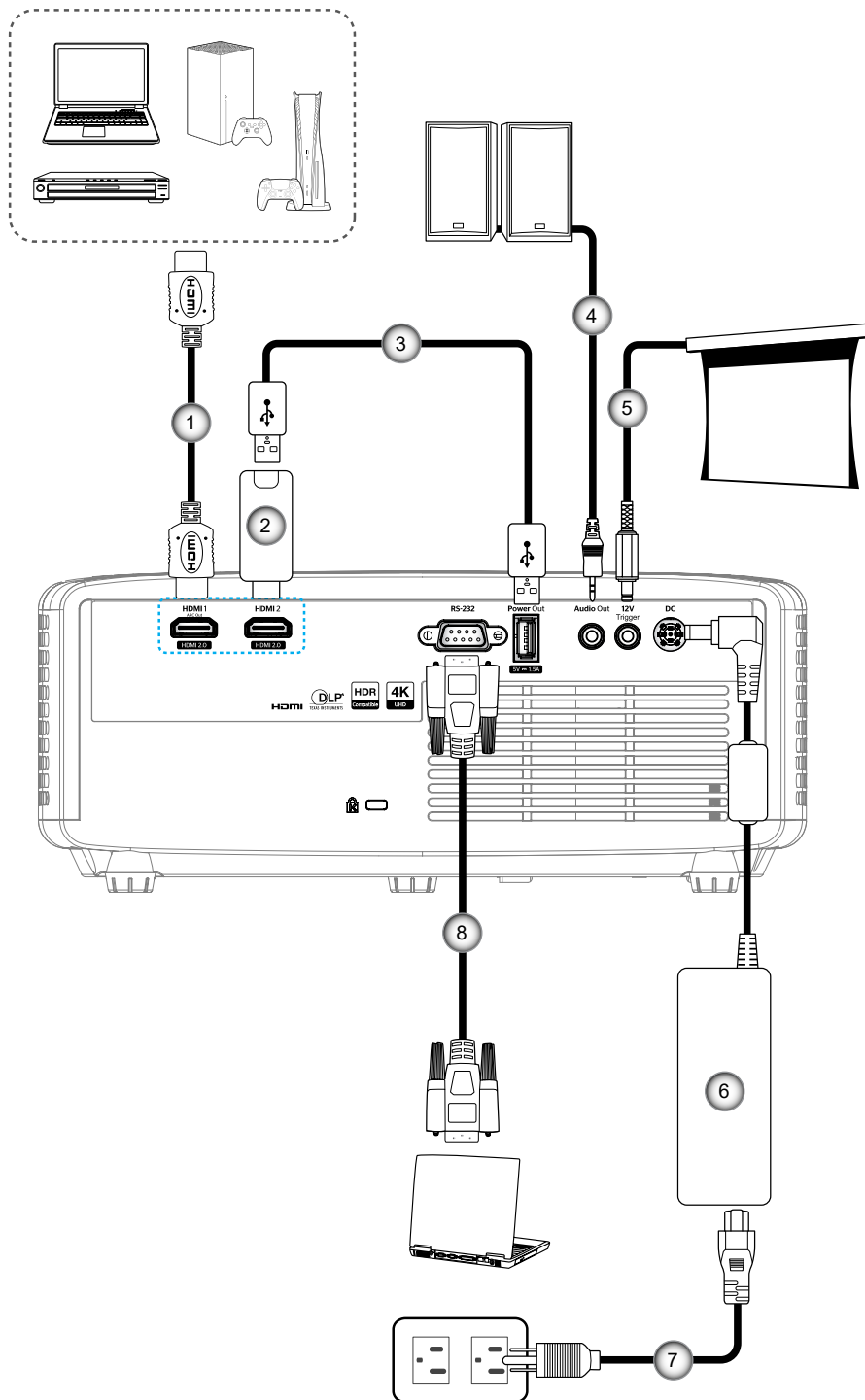

| No | Item | No | Item |
|----|-----------------|----|---------------|
| 1. | HDMI Cable | 5. | 12V DC Jack |
| 2. | HDMI Dongle | 6. | Power Adapter |
| 3. | USB Power Cable | 7. | Power Cable |
| 4. | Audio Out Cable | 8. | RS232 Cable |

Note: To ensure the best image quality and avoid connection errors, we recommend the use of High Speed or Premium Certified HDMI cables up to 5 meters.

SETUP AND INSTALLATION

Adjusting the projector image

Image height

The projector is equipped with elevator feet for adjusting the image height.

1. Locate the adjustable foot you wish to adjust on the underside of the projector.
2. Rotate the adjustable foot clockwise or counterclockwise to raise or lower the projector.

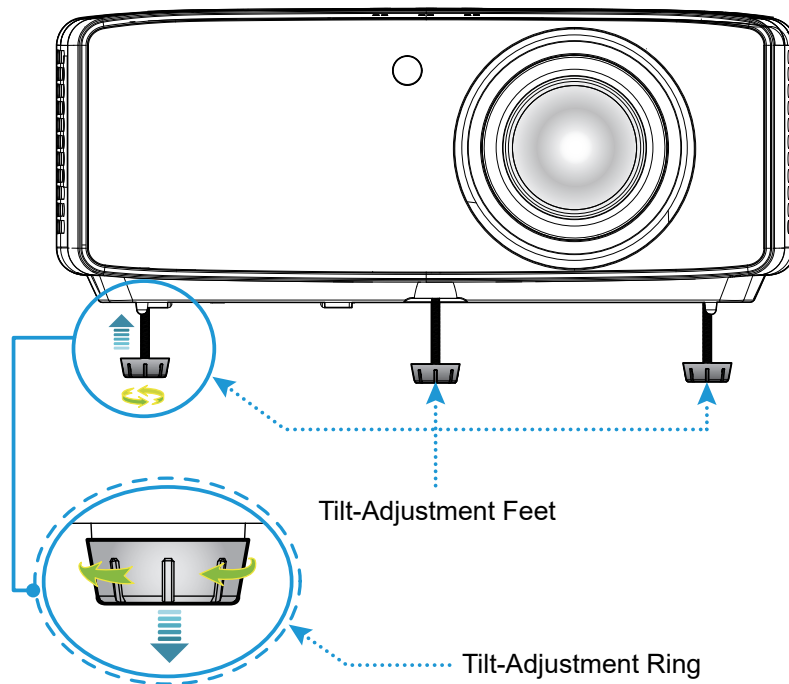

Zoom and focus

- To adjust the image size, turn the zoom lever clockwise or counterclockwise to increase or decrease the projected image size.
- To adjust the focus, turn the focus ring clockwise or counterclockwise until the image is sharp and legible.

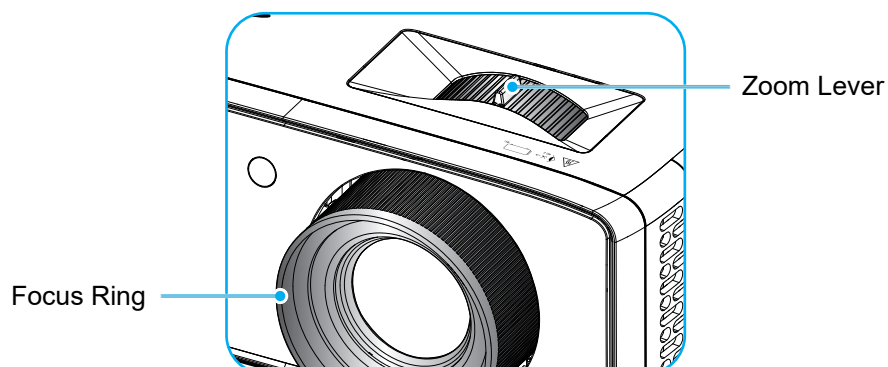

SETUP AND INSTALLATION

Remote setup

Installing / replacing the batteries

Two AAA size batteries are supplied for the remote control.

1. Remove the battery cover on the back of the remote control.
2. Insert AAA batteries in the battery compartment as illustrated.
3. Replace back cover on remote control.

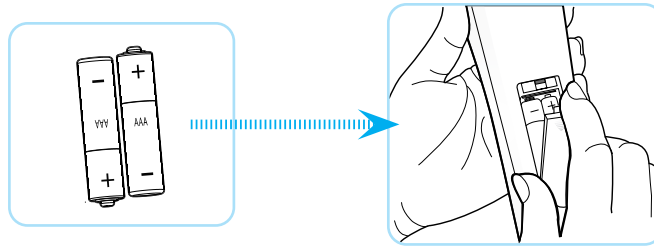

Note: Replace only with the same or equivalent type batteries.

CAUTION

Improper use of batteries can result in chemical leakage or explosion. Be sure to follow the instructions below.

- Do not mix batteries of different types. Different types of batteries have different characteristics.
- Do not mix old and new batteries. Mixing old and new batteries can shorten the life of new batteries or cause chemical leakage in old batteries.
- Remove batteries as soon as they are depleted. Chemicals that leak from batteries that come in contact with skin can cause a rash. If you find any chemical leakage, wipe thoroughly with a cloth.
- The batteries supplied with this product may have a shorter life expectancy due to storage conditions.
- If you will not be using the remote control for an extended period of time, remove the batteries.
- When you dispose of the batteries, you must obey the law in the relative area or country.

SETUP AND INSTALLATION

Effective range

Infra-Red (IR) remote control sensor is located on the top and front sides of the projector. Ensure to hold the remote control at an angle within 30 degrees perpendicular to the projector's IR remote control sensor to function correctly. The distance between the remote control and the sensor should not be longer than 6 meters (19.7 feet).

- Make sure that there are no obstacles between the remote control and the IR sensor on the projector that might obstruct the infra-red beam.
- Make sure the IR transmitter of the remote control is not being shined by sunlight or fluorescent lamps directly.
- Please keep the remote controller away from fluorescent lamps for over 2 m or the remote controller might become malfunction.
- If the remote control is close to Inverter-Type fluorescent lamps, it might become ineffective from time to time.
- If the remote control and the projector are within a very short distance, the remote control might become ineffective.
- When you aim at the screen, the effective distance is less than 5 m from the remote control to the screen and reflecting the IR beams back to the projector. However, the effective range might change according to screens.

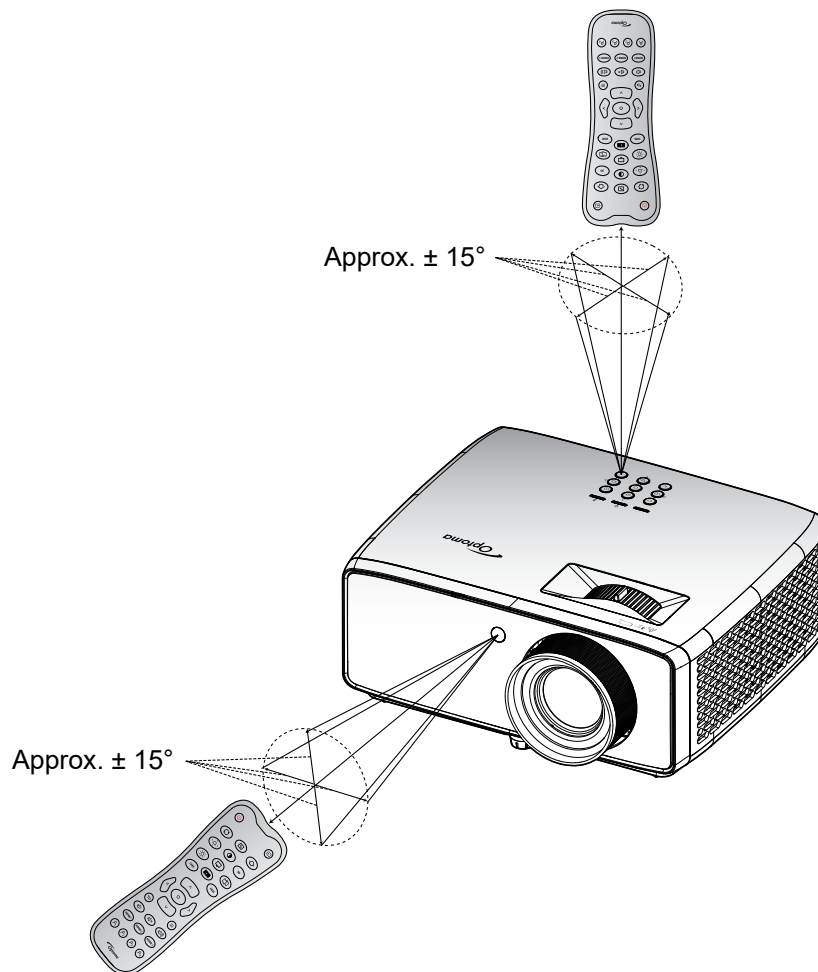

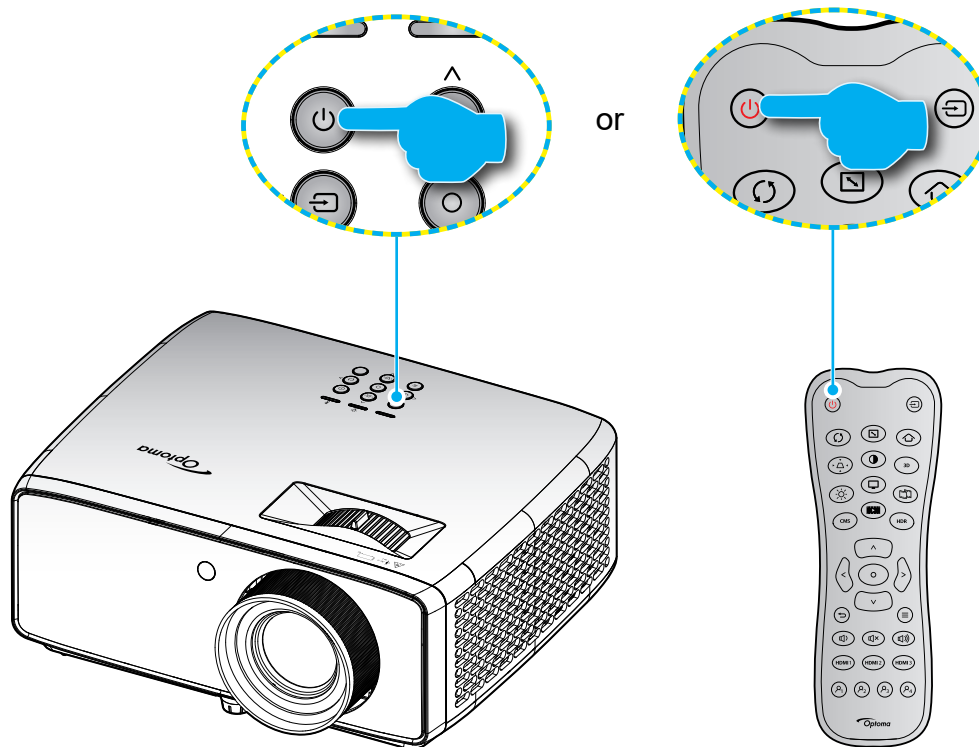

USING THE PROJECTOR

Powering on / off the projector



Powering on

1. Securely connect the power lead and signal/source cable. When connected, the Power LED will turn red.
2. Turn on the projector by pressing the  button on the projector keypad or the  button on the remote control.
3. A start up screen will display in approximately 10 seconds and the Power LED will be flashing blue.

Note: The first time the projector is turned on, you will be prompted to select the preferred language, projection orientation, and other settings.

USING THE PROJECTOR

The first time the projector is turned on, you will be prompted to do the initial setup including selecting the projection orientation, preferred language, and more. Once the **Setup Complete!** screen appears, it indicates the projector is ready to use.

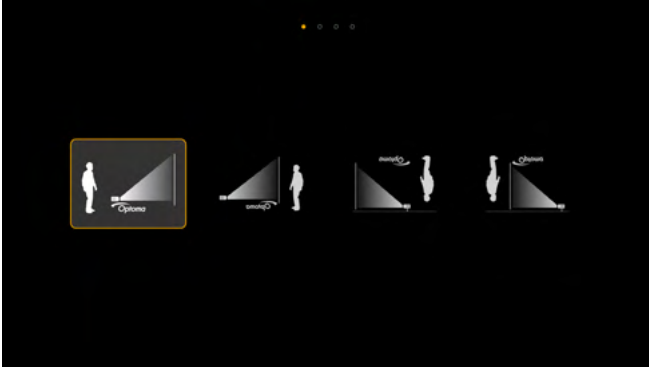

[Projection screen]



[Language screen]

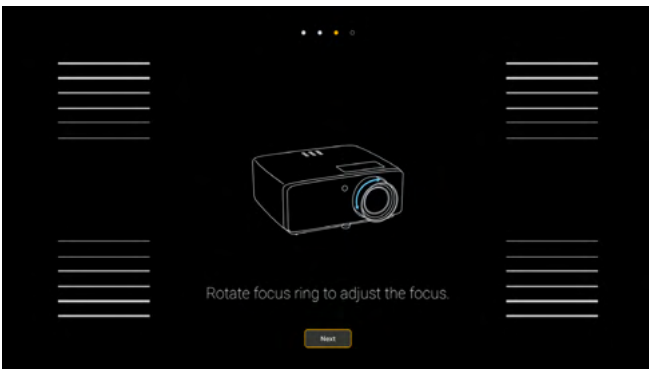

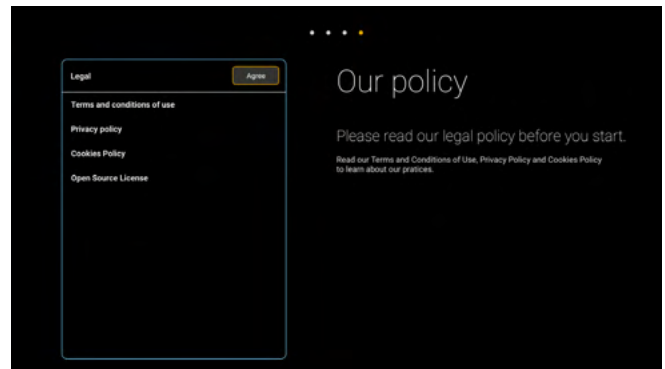

[Focus adjustment screen]







[Regulation screen]

USING THE PROJECTOR

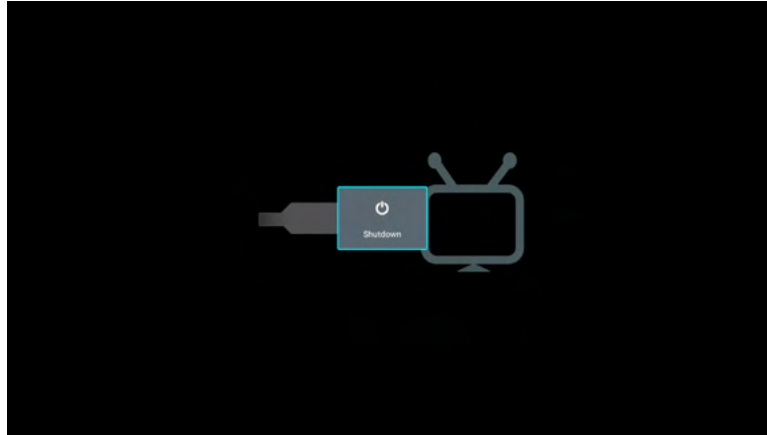
Powering off

1. Turn off the projector by pressing the  button on the projector keypad or the  button on the remote control.
2. The following message will be displayed:



3. Press the  button again to confirm, otherwise the message will disappear after 15 seconds. When you press the  button for the second time, the projector will shut down.
4. When the Power LED turns solid red, this indicates the projector has entered standby mode. When the projector is in standby mode, simply press the  button again to turn on the projector.
5. Disconnect the power lead from the electrical outlet and the projector.

Note: *It is not recommended that the projector is turned on immediately, right after a power off procedure.*

USING THE PROJECTOR

Selecting an input source

Turn on the connected source that you want to display on the screen, such as computer, notebook, video player, etc. The projector will automatically detect the source. If multiple sources are connected, press the  button on the projector keypad or remote control to select the desired input.

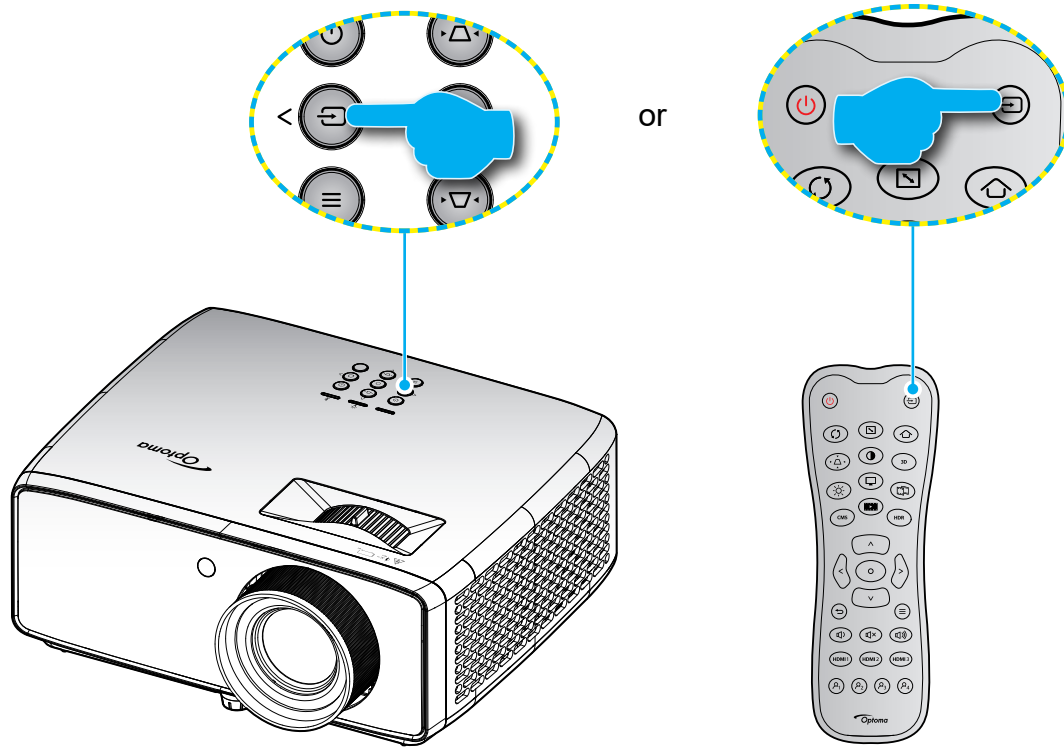

USING THE PROJECTOR

Menu navigation and features

The projector has multilingual on-screen display menus that allow you to make image adjustments and change a variety of settings. The projector will automatically detect the source.

1. To open the OSD menu, press the \equiv button on the projector keypad or remote control.
2. When OSD is displayed, use \wedge / \vee keys to select any item in the main menu. While making a selection on a particular page, press the \bigcirc button on the projector keypad or remote control to enter sub menu.
3. Use \lt / \gt keys to select the desired item in the sub menu and then press the \bigcirc button to view further settings. Adjust the settings by using $\wedge / \vee / \lt / \gt$ keys.
4. Select the next item to be adjusted in the sub menu and adjust as described above.
5. Press the \bigcirc button to confirm, and the screen will return to the main menu.
6. To exit, press the \equiv button again. The OSD menu will close and the projector will automatically save the new settings.

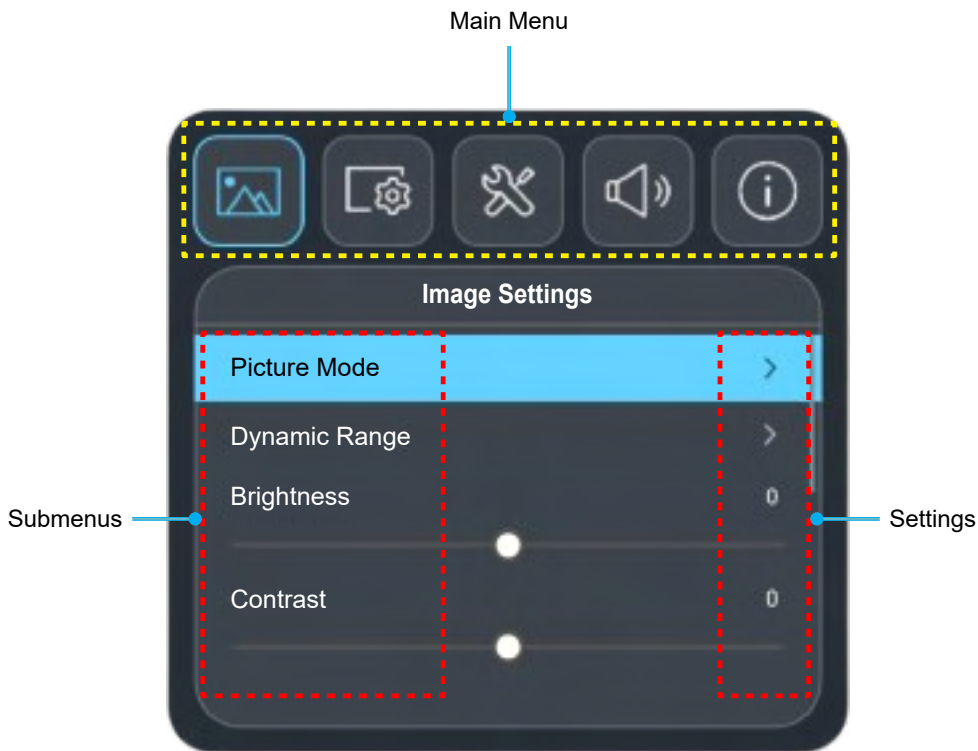

USING THE PROJECTOR

OSD Menu tree

Note: The OSD menu tree items and features are subject to models and region. Optoma reserve the right to add or remove items to improve product performance without notice.

| Main Menu | Sub Menu | Sub Menu 2 | Sub Menu 3 | Sub Menu 4 | Values | |
|-------------|-----------------|-------------------|------------|---------------------------------|--|--|
| Image | Picture Mode | | | | Vivid | |
| | | | | | HDR | |
| | | | | | Cinema | |
| | | | | | Game | |
| | | | | | Bright | |
| | | | | | Reference | |
| | | | | | FILMMAKER MODE | |
| | | | | | ISF Day | |
| | Dynamic Range | HDR | | | Off | |
| | | HDR Brightness | | | Auto | |
| | Brightness | | | | 0 ~ 5 | |
| | Contrast | | | | -50 ~ 50 | |
| | Sharpness | | | | -50 ~ 50 | |
| | Gamma | | | | 0 ~ 15 | |
| | | | | | Film | |
| | | | | | Graphics | |
| | | | | | 1.8 | |
| | | | | | 2.0 | |
| | | | | | 2.2 | |
| | Brightness Mode | Dynamic Black | | | 2.4 | |
| | | Power Mode | | | BT.1886 | |
| | PureEngine | PureContrast | | | Off | |
| | | PureMotion | | | On | |
| | | PureDetail | | | 100% / 95% / 90% / 85% / 80% / 75% / 70% / 65% / 60% / 55% / 50% | |
| | Color Settings | Color | | | Off / 1 / 2 / 3 | |
| | | Tint | | | Off / 1 / 2 / 3 | |
| | | Color Temperature | | | | Off / 1 / 2 / 3 |
| | | | | | | Standard |
| | | | | | | Cool |
| | | CMS | | Color | | Cold |
| | | | | Hue | | White / Red / Green / Blue / Cyan / Magenta / Yellow |
| | | | | Saturation | | -50 ~ 50 |
| | | | Luminance | | -50 ~ 50 | |
| | | | Reset | | -50 ~ 50 | |
| Color Space | | | | No | | |
| | | | | Yes | | |
| | | | | Auto / RGB(0~255) / RGB(16~235) | | |

USING THE PROJECTOR

| Main Menu | Sub Menu | Sub Menu 2 | Sub Menu 3 | Sub Menu 4 | Values | |
|-----------|-----------------------|------------------------|------------|------------|---------------------------------------|------------------|
| Image | Reset | | | | No | |
| | | | | | Yes | |
| Display | Aspect Ratio | | | | 4:3 | |
| | | | | | 16:9 | |
| | | | | | Native | |
| | | | | | Auto | |
| | Geometric Correction | Auto V Keystone | | | | Off |
| | | | | | | On |
| | | V Keystone | | | | -30 ~ 30 |
| | | H Keystone | | | | -30 ~ 30 |
| | | Four Corner Adjustment | | | | |
| Reset | | | | | | |
| Reset | | | | | | |
| Setup | Test Pattern | | | | Green Grid | |
| | | | | | Magenta Grid | |
| | | | | | White Grid | |
| | | | | | White | |
| | | | | | Off | |
| | ProjectionOrientation | | | | Front / Rear / Ceiling-Top / Rear-Top | |
| | Language | | | | | English |
| | | | | | | عربي |
| | | | | | | Čeština |
| | | | | | | Dansk |
| | | | | | | Nederlands |
| | | | | | | فارسی |
| | | | | | | Suomi |
| | | | | | | Français |
| | | | | | | Deutsch |
| | | | | | | ελληνικά |
| | | | | | | Magyar |
| | | | | | | Bahasa Indonesia |
| | | | | | | Italiano |
| | | | | | | 日本語 |
| | | | | | | 한국어 |
| | | | | | | Norsk |
| | | | | | | Polski |
| | | | | | Português | |
| | | | | Română | | |
| | | | | Русский | | |
| | | | | 简体中文 | | |
| | | | | Español | | |
| | | | | Svenska | | |

USING THE PROJECTOR

| Main Menu | Sub Menu | Sub Menu 2 | Sub Menu 3 | Sub Menu 4 | Values | | |
|-----------|-----------------------|-----------------|------------|------------|--|--|-------------|
| Setup | Language | | | | ไทย | | |
| | | | | | 繁體中文 | | |
| | | | | | Türkçe | | |
| | | | | | Tiếng Việt | | |
| | High Altitude | | | | | Off | |
| | | | | | | On | |
| | Power Settings | Direct Power On | | | | Off | |
| | | | | | | On | |
| | | Signal Power On | | | | Off | |
| | | | | | | On | |
| | Auto Power Off (min.) | | | | 0, 2~ 180 (1 min increments) | | |
| | 12V Trigger | | | | | Off | |
| | | | | | | On | |
| | Auto Source | | | | | Off | |
| | | | | | | On | |
| | HDMI CEC Settings | HDMI Link | | | | Off | |
| | | | | | | On | |
| | | Power On Link | | | | | Mutual |
| | | | | | | | PJ → Device |
| | | | | | | | Device → PJ |
| | | | | | | | Mutual |
| | Power Off Link | | | | | PJ → Device | |
| | | | | | | Device → PJ | |
| | Background Color | | | | | None | |
| | | | | | | Blue | |
| | | | | | | Red | |
| | | | | | | Green | |
| | | | | | | Grey | |
| | Keypad Settings | Keypad Lock | | | | Off | |
| | | | | | | On | |
| | Remote Settings | IR Function | | | | Both / Front / Top | |
| | | User1 | | | | Empty/Brightness/Contrast/Sharpness/Color/Color Temperature/CMS/Geometric Correction/Test Pattern/Projection Orientation/V Keystone/Four Corners | |
| User2 | | | | | Empty/Brightness/Contrast/Sharpness/Color/Color Temperature/CMS/Geometric Correction/Test Pattern/Projection Orientation/V Keystone/Four Corners | | |
| User3 | | | | | Empty/Brightness/Contrast/Sharpness/Color/Color Temperature/CMS/Geometric Correction/Test Pattern/Projection Orientation/V Keystone/Four Corners | | |
| User4 | | | | | Empty/Brightness/Contrast/Sharpness/Color/Color Temperature/CMS/Geometric Correction/Test Pattern/Projection Orientation/V Keystone/Four Corners | | |

USING THE PROJECTOR

| Main Menu | Sub Menu | Sub Menu 2 | Sub Menu 3 | Sub Menu 4 | Values | |
|--------------------|-----------------------|---------------|------------|------------|---------|----------------------|
| Setup | Device ID | | | | 0~99 | |
| | USB System Update | | | | No | |
| | | | | | | Yes |
| | Device Reset | Reset OSD | | | | No |
| | | | | | | Yes |
| | Reset All Settings | | | | No | |
| | | | | | Yes | |
| Audio | Volume | | | | 0 ~ 100 | |
| | Mute | | | | Off | |
| | | | | | | On |
| | Audio Output | | | | | Auto |
| | | | | | | Internal Speaker |
| | Audio Output Settings | | | | | Line Out (3.5mm) |
| | | | | | | Analog |
| Reset | | | | | ARC | |
| | | | | | No | |
| | | | | | Yes | |
| Information | About | Regulatory | | | | |
| | | Serial Number | | | | |
| | | FW Version | DDP | | | |
| | | | MCU | | | |
| | Scalar | | | | | |
| | Source | | | | | |
| | Source Info. | | | | | Resolution(00x00) |
| | | | | | | Refresh Rate(0.00Hz) |
| | Picture Mode | | | | | |
| | Color Info. | | | | | Color Bit Depth |
| | | | | | | Color Gamut |
| | | | | | | Color Space |
| Light Source Hours | | | | | | |
| Brightness Mode | | | | | | |

USING THE PROJECTOR

Image menu

Image picture mode menu

There are several predefined display modes that you can choose from to suit your viewing preference. Each mode has been fine-tuned by our expert colour team to ensure superior colour performance for wide range of content.

- **Vivid:** In this mode, the color saturation and brightness are well-balanced. Choose this mode for playing games.
- **HDR:** Decodes and displays High Dynamic Range (HDR) content for the deepest blacks, brightest whites, and vivid cinematic color using REC.2020 color gamut. This mode will be automatically enabled if HDR is set to Auto (and HDR Content is sent to projector – 4K UHD Blu-ray, 1080p/4K UHD HDR Games, 4K UHD Streaming Video). While HDR mode is active, other display modes (Cinema, Reference, etc.) cannot be selected as HDR delivers color that is highly accurate, exceeding the color performance of the other display modes.
- **Cinema:** Provides the best balance of detail and colors for watching movies.
- **Game:** Optimises your projector for maximum contrast and vivid colours allowing you to see shadow detail when playing video games.
- **Bright:** This mode is suitable for environments where extra-high brightness is required, such as using the projector in well-lit rooms.
- **Reference:** This mode reproduces colours as close as possible the image the way the movie director intended. Color, color temperature, brightness, contrast and gamma settings are all configured to Rec.709 color gamut. Select this mode for the most accurate colour reproduction when watching movies.
- **FILMMAKER MODE:** By disabling all post-processing (e.g. motion smoothing) and preserving the correct aspect ratios, colors and frame rates, Filmmaker Mode enables the projector to display the video content precisely as it was intended by the filmmaker. For more information on FILMMAKER Mode, please visit: <https://filmmakermode.com/>.
- **ISF Day:** Optimize the image with the ISF Day mode to be perfectly calibrated and high picture quality.
- **ISF Night:** Optimize the image with the ISF Night mode to be perfectly calibrated and high picture quality.

Image dynamic range menu

HDR

Configure the High Dynamic Range (HDR) setting and its effect when displaying video from 4K Blu-ray players and streaming devices.

- **Off:** Turn off HDR Processing. When set to Off, the projector will NOT decode HDR content.
- **Auto:** Auto detect HDR signal.

HDR Brightness

Adjust the HDR strength if **HDR** is set as **Auto**.

Image brightness menu

Adjust the brightness of the image.

Image contrast menu

The contrast controls the degree of difference between the lightest and darkest parts of the picture.

USING THE PROJECTOR

Image sharpness menu

Adjust the sharpness of the image.

Image gamma menu

Set up gamma curve type. After the initial setup and fine tuning is completed, utilize the Gamma Adjustment steps to optimize your image output.

- **Film:** For home theater.
- **Graphics:** For PC / Photo source.
- **1.8 / 2.0 / 2.2 / 2.4 / BT.1886:** For specific PC / Photo source.

Image brightness mode menu

Dynamic Black

Use to automatically adjust the picture brightness in order to give optimum contrast performance.

Power Mode

Choose the power percentage for brightness mode.

Image PureEngine menu

PureContrast

Use to automatically optimize the brightness of the display during dark / light movie scenes to be shown in incredible detail.

PureMotion

Use to preserve a natural motion of the displayed image.

PureDetail

Use to significantly increase the image's sharpness.

Image color settings menu

Color

Adjust a video image from black and white to fully saturated color.

Tint

Adjust the color balance of red and green.

Color Temperature

Select a color temperature from Standard, Cool, or Cold.

CMS

Select the following options:

- **Color:** Adjust the red, green, blue, cyan, yellow, magenta, and white level of the image.
- **Hue:** Adjust the color balance of red and green.
- **Saturation:** Adjust a video image from black and white to fully saturated color.
- **Luminance:** Adjust the luminance of the selected color.
- **Reset:** Return the factory default settings for color adjustment.

USING THE PROJECTOR

Color Space

Select an appropriate color matrix type from the following: Auto, RGB(0~255), and RGB(16~235).

Image reset menu

Return the factory default settings for image settings.

USING THE PROJECTOR

Display menu

Display aspect ratio menu

Select the aspect ratio of the displayed image between the following options:

- **4:3:** This format is for 4:3 input sources.
- **16:9:** This format is for 16:9 input sources, like HDTV and DVD enhanced for Wide screen TV.
- **Native:** This format displays the original image without any scaling.
- **Auto:** Automatically selects the appropriate display format.

4K UHD DMD scaling table:

| 16:9 screen | 480i/p | 576i/p | 720p | 1080i/p | 2160p |
|-------------|--|--------|------|---------|-------|
| 4x3 | Scale to 2880 x 2160 | | | | |
| 16x9 | Scale to 3840 x 2160 | | | | |
| Auto | If the source is 4:3, auto resize to 2880 x 2160 | | | | |

4K UHD DMD auto mapping rule:

| Auto | Input resolution | | Auto/Scale | |
|-------------|------------------|--------------|------------|------|
| | H-resolution | V-resolution | 3840 | 2160 |
| 4:3 | 800 | 600 | 2880 | 2160 |
| | 1024 | 768 | 2880 | 2160 |
| | 1280 | 1024 | 2880 | 2160 |
| | 1400 | 1050 | 2880 | 2160 |
| | 1600 | 1200 | 2880 | 2160 |
| Wide Laptop | 1280 | 720 | 3840 | 2160 |
| | 1280 | 768 | 3600 | 2160 |
| | 1280 | 800 | 3456 | 2160 |
| SDTV | 720 | 576 | 2700 | 2160 |
| | 720 | 480 | 3240 | 2160 |
| HDTV | 1280 | 720 | 3840 | 2160 |
| | 1920 | 1080 | 3840 | 2160 |

USING THE PROJECTOR

Display geometric correction menu

Auto V Keystone

Correct keystone digitally to fit the projected image on the area on which you are projecting.

Note:

- *The image size will reduce slightly when adjusting the horizontal and vertical keystone.*
- *When the Auto V Keystone is used, the V/H Keystone and Four Corner Adjustment function will be disabled.*

V Keystone

Adjust image distortion vertically and make a squarer image. Vertical keystone is used to correct a keystone image shape in which the top and bottom are slanted to one of the sides. This is intended when for use with vertically on-axis applications.

H Keystone

Adjust image distortion horizontally and make a squarer image. Horizontal keystone is used to correct a keystone image shape in which the left and right borders of the image are unequal in length. This is intended for use with horizontally on-axis applications.

Four Corner Adjustment

This setting allows the projected image to be adjusted from each corner to make a square image when the projection surface is not level.

Reset

Return the factory default setting for geometric correction settings.

Display reset menu

Return the factory default settings for display settings.

USING THE PROJECTOR

Setup menu

Setup test pattern menu

Select the test pattern from green grid, magenta grid, white grid, white, or disable this function (off).

Setup projection orientation menu

Select the preferred projection between front, rear, ceiling-top, and rear-top.

Setup language menu

Select the multilingual OSD menu.

Setup high altitude menu

When "On" is selected, the fans will spin faster. This feature is useful in high altitude areas where the air is thin.

Setup power settings menu

Direct Power On

Choose "On" to activate Direct Power mode. The projector will automatically power on when AC power is supplied, without pressing the "Power" key on the projector keypad or on the remote control.

Signal Power On

Choose "On" to activate Signal Power mode. The projector will automatically power on when a signal is detected, without pressing the "Power" key on the projector Keypad or on the remote control.

Note:

- *This function is applicable with HDMI source.*

Auto Power Off (min.)

Sets the countdown timer interval. The countdown timer will start, when there is no signal being sent to the projector. The projector will automatically power off when the countdown has finished (in minutes).

12V Trigger

Use this function to enable or disable the trigger.

Note: 3.5mm mini jack that outputs 12V 500mA (max.) for relay system control.

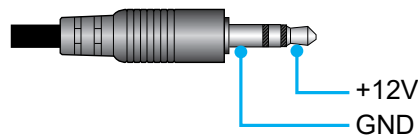

- **On:** Choose "On" to enable the trigger.
- **Off:** Choose "Off" to disable the trigger.

Setup auto source menu

Choose this option to let the projector automatically find an available input source.

USING THE PROJECTOR

Setup HDMI CEC settings menu

Note: When you connect HDMI CEC-compatible devices to the projector with HDMI cables, you can control them on the same power on or power off status using the HDMI Link control feature in the projector's OSD. This lets one device or multiple devices in a group power on or power off via HDMI Link Feature in a typical configuration, your DVD player may be connected to the projector through an amplifier or home theater system.

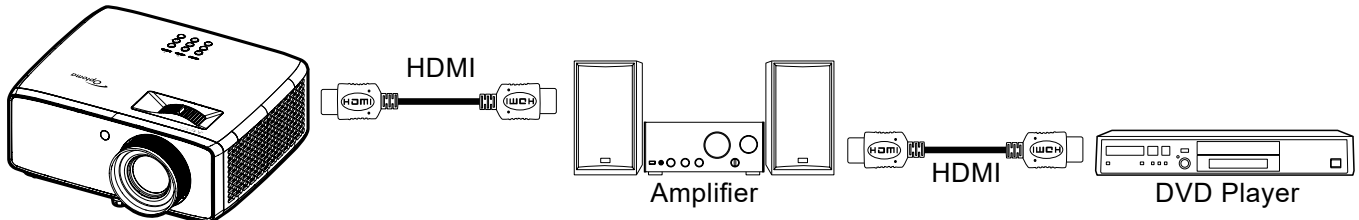

HDMI Link

Enable/disable the HDMI Link function.

Power On Link

CEC power on command.

- **Mutual:** Both projector and CEC device will be turned on simultaneously.
- **PJ → Device:** The CEC device will be turned on only after the projector is switched on.
- **Device → PJ:** The projector will be switched on only after the CEC device is turned on.

Power Off Link

CEC power on command.

- **Mutual:** Both projector and CEC device will be turned off simultaneously.
- **PJ → Device:** The CEC device will be turned off only after the projector is switched off.
- **Device → PJ:** The projector will be switched off only after the CEC device is turned off.

Setup background color menu

Use this function to display a blue, red, green, grey color, or none when no signal is available.

Note: If the background color is set to "None", then the background color is black.

Setup keypad settings menu

Keypad Lock

When the keypad lock function is "On", the Keypad will be locked. However, the projector can be operated by the remote control. By selecting "Off", you will be able to reuse the Keypad.

USING THE PROJECTOR

Setup remote settings menu

IR Function

Set the IR function setting.

- **Both:** Choose “Both”, the projector can be operated by the remote control from the top and front IR receivers.
- **Front:** Enable or disable the front remote receiver.
- **Top:** Enable or disable the top remote receiver.

User1 / User2 / User3 / User4

Assign a function to the User1, User2, User3, and User4 buttons on the remote control. It allows you to use the function easily without going through the OSD menus.

Setup device ID menu

ID definition can be set up by menu (range 0-99), and allow user control an individual projector by using RS232 command.

Note: For a full list of RS232 commands, please refer to the RS232 user manual on our website.

Setup USB system update menu

Manually update the system firmware.

Setup device reset menu

Reset OSD

Return the factory default settings for OSD menu settings.

Reset All Settings

Return the factory default settings for all settings.

USING THE PROJECTOR

Audio menu

Audio volume menu

Adjust the volume level.

Audio mute menu

Use this option to temporarily turn off the sound.

- **On:** Choose “On” to turn mute on.
- **Off:** Choose “Off” to turn mute off.

Note: *“Mute” function affects both internal and external speaker volume.*

Audio audio output menu

Select the audio output between Auto, Internal Speaker, and Line Out (3.5mm).

Audio audio output settings menu

Select the audio output format between Analog and ARC.

Audio reset menu

Return the factory default settings for audio settings.

USING THE PROJECTOR

Information menu

Information menu

View the projector information as listed below:

- About
- Source
- Source Info.
- Picture Mode
- Color Info.
- Light Source Hours
- Brightness Mode

ADDITIONAL INFORMATION

Compatible resolutions

Input Signal for HDMI

| Signal | Resolution | Refresh Rate(Hz) | Notes for Mac |
|-------------|------------|------------------|---------------|
| VGA | 640x480 | 60/67/72/75 | Mac 60/75 |
| | 720x400 | 70 | |
| SVGA | 800x600 | 56/60/72/75 | Mac 60/75 |
| | 832x624 | 75 | Mac 75 |
| XGA | 1024x768 | 60/70/75/120 | Mac 60/70/75 |
| SDTV(480P) | 720x480 | 60 | |
| SDTV(576P) | 720x576 | 50 | |
| HDTV(720P) | 1280x720 | 60/120 | Mac 60 |
| WXGA | 1280x800 | 60 | Mac 60 |
| | 1440x900 | 60 | |
| SXGA | 1280x1024 | 60/75 | Mac 60/75 |
| | 1440x900 | 60 | |
| SXGA+ | 1400x1050 | 60 | |
| UXGA | 1600x1200 | 60 | |
| HDTV(1080I) | 1920x1080 | 60 | |
| HDTV(1080p) | 1920x1080 | 24/50/60/120 | Mac 60 |
| WQHD | 2560x1440 | 120 | |
| UHD(2160p) | 3840x2160 | 24/30/50/60 | |
| | 4096x2160 | 24/60 | |

ADDITIONAL INFORMATION

EDID (Digital)

| B0/Established Timing | | B0/Standard Timing | | B0/Detail Timing | | B1/Video Mode | | B1/Detail Timing | |
|-----------------------|----------|--------------------|--------|------------------|--------|--------------------|--------|------------------|--------|
| Resolution | V [Hz] | Resolution | V [Hz] | Resolution | V [Hz] | Resolution | V [Hz] | Resolution | V [Hz] |
| 720x400 | 70.0 | 1024x768 | 120.0 | 3840x2160 | 60.0 | 640x480p 4:3 | 60.0 | 2560x1440 | 120.00 |
| 640x480 | 60.0 | 1280x720 | 60.0 | | | 720x480p 16:9 | 60.0 | | |
| 640x480 | 66.6(67) | 1280x720 | 120.0 | | | 1280x720p 16:9 | 60.0 | | |
| 640x480 | 72.0 | 1280x800 | 60.0 | | | 1920x1080i 16:9 | 60.0 | | |
| 640x480 | 75.0 | 1280x1024 | 60.0 | | | 1920x1080p 16:9 | 60.0 | | |
| 800x600 | 56.0 | 1440x900 | 60.0 | | | 720x576p 16:9 | 50.0 | | |
| 800x600 | 60.0 | 1400x1050 | 60.0 | | | 1280x720p 16:9 | 50.0 | | |
| 800x600 | 72.0 | 1600x1200 | 60.0 | | | 1920x1080i 16:9 | 50.0 | | |
| 800x600 | 75.0 | | | | | 1920x1080p 16:9 | 50.0 | | |
| 832x624 | 75.0 | | | | | 1920x1080p 16:9 | 24.0 | | |
| 1024x768 | 60.0 | | | | | 1920x1080p 16:9 | 120.0 | | |
| 1024x768 | 70.0 | | | | | 2560x1080p 64:27 | 50.0 | | |
| 1024x768 | 75.0 | | | | | 2560x1080p 64:27 | 60.0 | | |
| 1280x1024 | 75.0 | | | | | 3840x2160p 16:9 | 24.0 | | |
| 1152x870 | 75.0 | | | | | 3840x2160p 16:9 | 30.0 | | |
| | | | | | | 3840x2160p 16:9 | 50.0 | | |
| | | | | | | 3840x2160p 16:9 | 60.0 | | |
| | | | | | | 4096x2160p 256:135 | 24.0 | | |
| | | | | | | 4096x2160p 256:135 | 60.0 | | |

ADDITIONAL INFORMATION

Image size and projection distance

| Desired Image Size | | | | | | Projection Distance (C) | | | | Offset (Hd) | |
|--------------------|------|--------|------|--------|------|-------------------------|------|-------|-------|-------------|-------|
| Diagonal | | Width | | Height | | Wide | | Tele | | | |
| inch | m | inch | m | inch | m | inch | m | inch | m | inch | m |
| 28 | 0.71 | 24.40 | 0.62 | 13.73 | 0.35 | / | / | 3.25 | 0.99 | 0.69 | 0.018 |
| 30 | 0.76 | 26.15 | 0.66 | 14.71 | 0.37 | / | / | 3.48 | 1.06 | 0.73 | 0.019 |
| 40 | 1.02 | 34.86 | 0.89 | 19.60 | 0.50 | 3.51 | 1.07 | 4.63 | 1.41 | 0.98 | 0.025 |
| 50 | 1.27 | 43.58 | 1.11 | 24.50 | 0.62 | 4.40 | 1.34 | 5.77 | 1.76 | 1.22 | 0.031 |
| 60 | 1.52 | 52.29 | 1.33 | 29.40 | 0.75 | 5.28 | 1.61 | 6.92 | 2.11 | 1.48 | 0.038 |
| 70 | 1.78 | 61.01 | 1.55 | 34.30 | 0.87 | 6.17 | 1.88 | 8.07 | 2.46 | 1.71 | 0.044 |
| 80 | 2.03 | 69.73 | 1.77 | 39.20 | 1.00 | 7.02 | 2.14 | 9.25 | 2.82 | 1.97 | 0.050 |
| 90 | 2.29 | 78.44 | 1.99 | 44.10 | 1.12 | 7.91 | 2.41 | 10.40 | 3.17 | 2.20 | 0.056 |
| 100 | 2.54 | 87.16 | 2.21 | 49.00 | 1.25 | 8.79 | 2.68 | 11.55 | 3.52 | 2.46 | 0.063 |
| 120 | 3.05 | 104.59 | 2.66 | 58.80 | 1.49 | 10.53 | 3.21 | 13.85 | 4.22 | 2.93 | 0.075 |
| 150 | 3.81 | 130.74 | 3.32 | 73.50 | 1.87 | 13.19 | 4.02 | 17.32 | 5.28 | 3.68 | 0.094 |
| 180 | 4.57 | 156.88 | 3.98 | 88.20 | 2.24 | 15.81 | 4.82 | 20.80 | 6.34 | 4.41 | 0.112 |
| 200 | 5.08 | 174.32 | 4.43 | 98.10 | 2.49 | 17.59 | 5.36 | 23.10 | 7.04 | 4.90 | 0.125 |
| 250 | 6.35 | 217.89 | 5.53 | 122.60 | 3.11 | 21.98 | 6.7 | 28.87 | 8.8 | 6.12 | 0.156 |
| 300 | 7.62 | 261.47 | 6.64 | 147.10 | 3.74 | 26.38 | 8.04 | 34.65 | 10.56 | 7.36 | 0.187 |

Note: Zoom Ratio: 1.3x

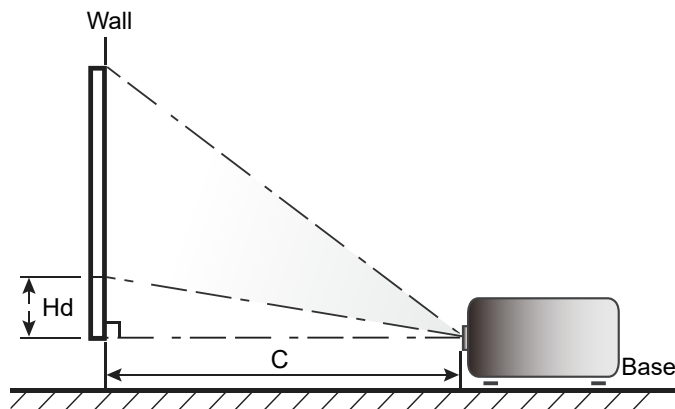

ADDITIONAL INFORMATION

Projector dimensions and ceiling mount installation

1. To prevent damage to your projector, please use the Optoma ceiling mount.
2. If you wish to use a third party ceiling mount kit, please ensure the screws used to attach a mount to the projector meet the following specifications:
 - Screw type: M4*5mm
 - Minimum screw length: 5mm

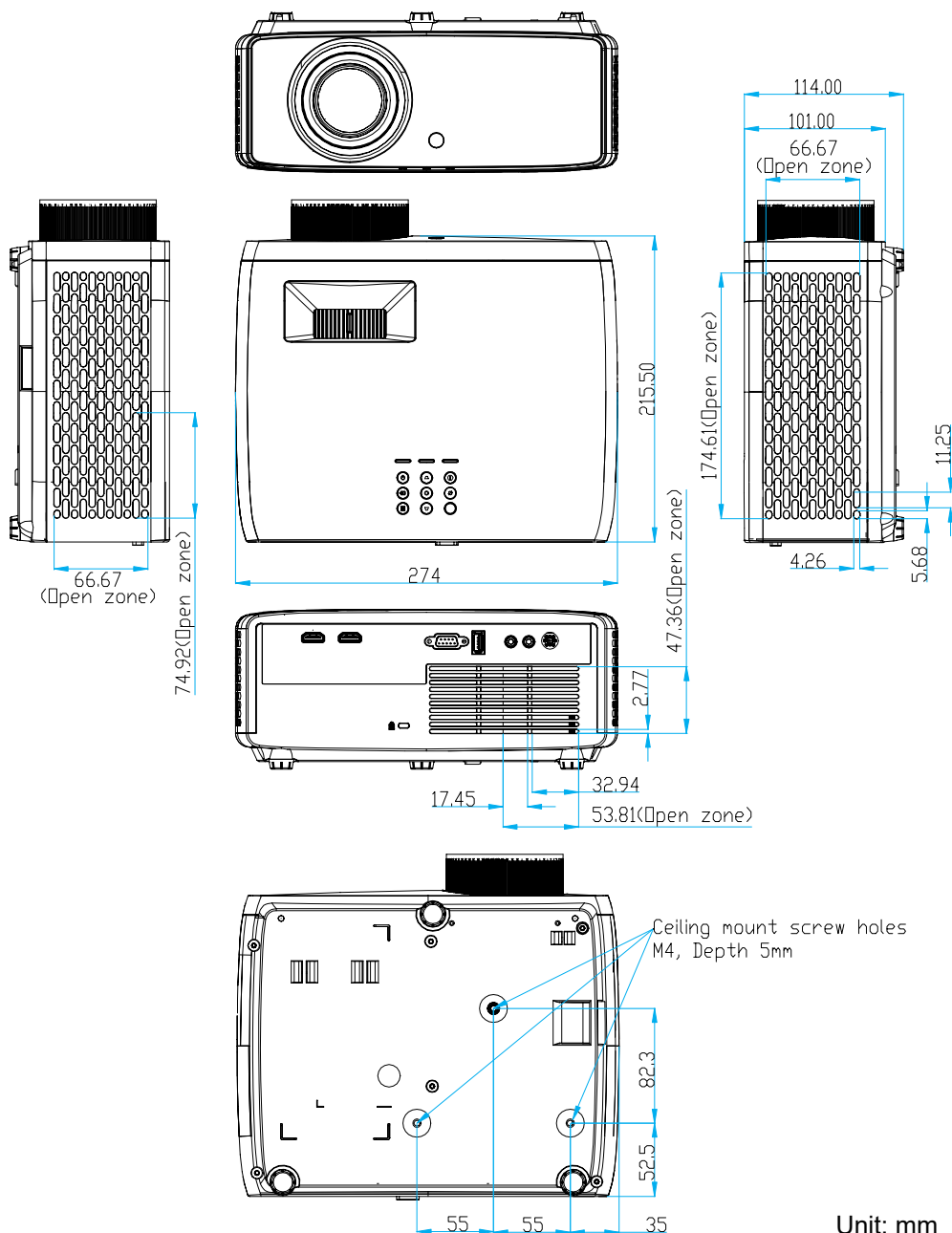

Note: Please note that damage resulting from incorrect installation will void the warranty.



Warning:

- If you buy a ceiling mount from another company, please be sure to use the correct screw size. Screw size will vary depending on the thickness of the mounting plate.
- Be sure to keep at least 10 cm gap between the ceiling and the bottom of the projector.
- Avoid installing the projector near a heat source.

ADDITIONAL INFORMATION

For ceiling mounting, you could purchase a cable tie whose length is over 250mm to fix the AC adapter if needed.

1. Install the cable tie to the designated holes on the bottom of the projector. Then place the AC adapter onto its slot.

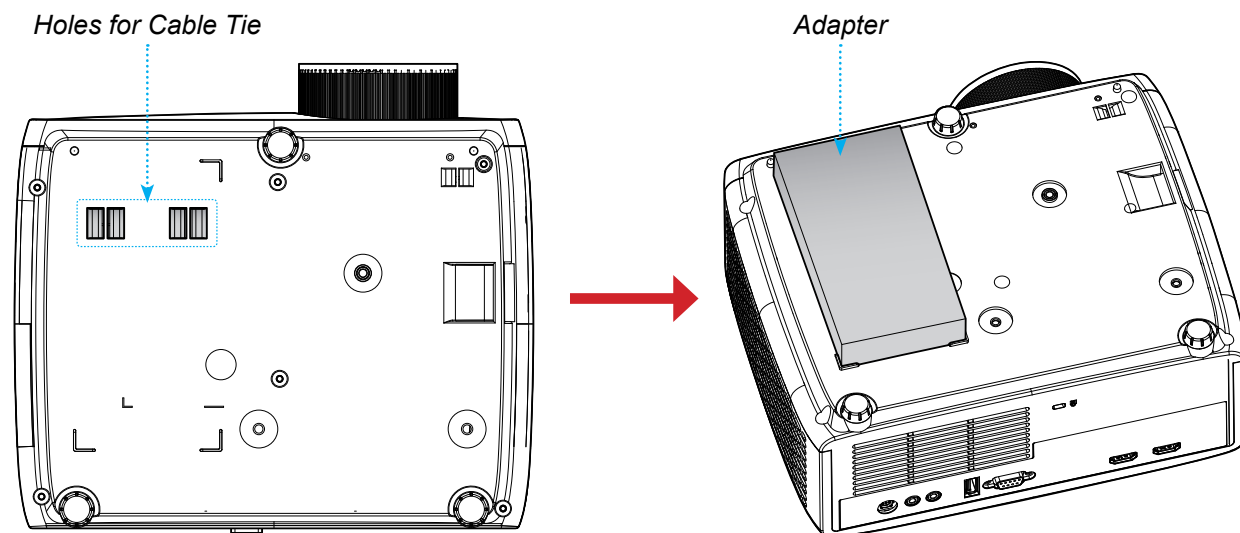

2. Secure the AC adapter with the cable tie.

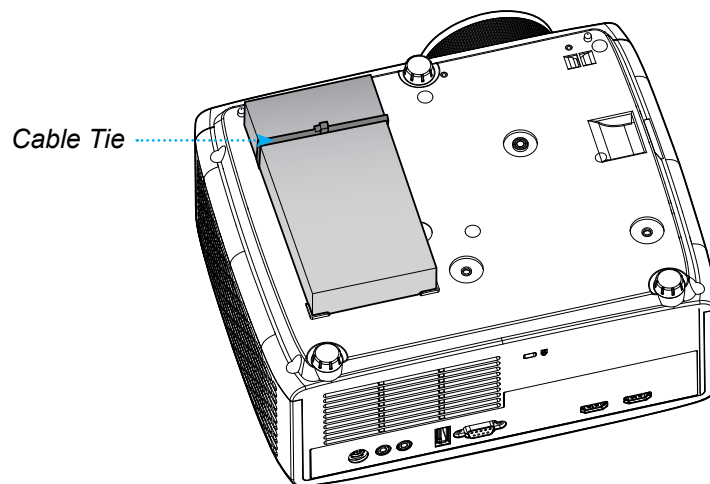



ADDITIONAL INFORMATION

IR remote control codes



| Key | | NEC Format | Byte 1 | Byte 2 | Byte 3 | Byte 4 |
|-------------------------------------|--|------------|--------|--------|--------|--------|
| Power on | | Format 1 | 32 | CD | 02 | FD |
| Source | | Format 1 | 32 | CD | C3 | 3C |
| Re-sync | | Format 1 | 32 | CD | C4 | 3B |
| Aspect Ratio | | Format 1 | 32 | CD | 64 | 9B |
| Home | | Format 1 | 32 | CD | 92 | 6D |
| Keystone | | Format 1 | 32 | CD | 07 | F8 |
| Contrast | | Format 1 | 32 | CD | 42 | BD |
| 3D (not supported) | | Format 1 | 32 | CD | 89 | 76 |
| Brightness | | Format 1 | 32 | CD | 41 | BE |
| Mode | | Format 1 | 32 | CD | 05 | FA |
| Low Latency Mode (not supported) | | Format 1 | 32 | CD | DD | 22 |

ADDITIONAL INFORMATION







| Key | | NEC Format | Byte 1 | Byte 2 | Byte 3 | Byte 4 |
|--------------------------|---|------------|--------|--------|--------|--------|
| CMS | CMS | Format 1 | 32 | CD | F0 | 0F |
| FILMMAKER MODE |  | Format 1 | 32 | CD | DF | 20 |
| HDR | HDR | Format 1 | 32 | CD | DC | 23 |
| Four direction keys | ^ | Format 2 | 32 | CD | 11 | EE |
| | v | Format 2 | 32 | CD | 14 | EB |
| | < | Format 2 | 32 | CD | 10 | EF |
| | > | Format 2 | 32 | CD | 12 | ED |
| Enter |  | Format 2 | 32 | CD | 0F | F0 |
| Return |  | Format 1 | 32 | CD | 0D | F2 |
| Menu |  | Format 2 | 32 | CD | 0E | F1 |
| Vol - |  | Format 2 | 32 | CD | DA | 25 |
| Mute |  | Format 1 | 32 | CD | 52 | AD |
| Vol + |  | Format 2 | 32 | CD | 8C | 73 |
| HDMI1 | HDMI 1 | Format 1 | 32 | CD | 16 | E9 |
| HDMI2 | HDMI 2 | Format 1 | 32 | CD | 30 | CF |
| HDMI3 (not supported) | HDMI 3 | Format 1 | 32 | CD | 98 | 67 |
| User1 |  | Format 1 | 32 | CD | 36 | C9 |
| User2 |  | Format 1 | 32 | CD | 65 | 9A |
| User3 |  | Format 1 | 32 | CD | 66 | 99 |
| User4 |  | Format 1 | 32 | CD | 09 | F6 |

ADDITIONAL INFORMATION

Troubleshooting

If you experience a problem with your projector, please refer to the following information. If a problem persists, please contact your local reseller or service center.

Image problems

-  *No image appears on-screen*
- Ensure all the cables and power connections are correctly and securely connected as described in the "Installation" section.
 - Ensure the pins of connectors are not crooked or broken.
 - Ensure that the "Mute" feature is not turned on.
-  *Image is out of focus*
- Turn the focus ring clockwise or counterclockwise until the image is sharp and legible. (Please see page 18).
 - Make sure the projection screen is between the required distance from the projector. (Please refer to page 42).
-  *The image is stretched when displaying 16:9 DVD title*
- When you play anamorphic DVD or 16:9 DVD, the projector will show the best image in 16: 9 format on projector side.
 - If you play the V-Stretch format DVD title, please change the format as V-Stretch in projector OSD.
 - If you play 4:3 format DVD title, please change the format as 4:3 in projector OSD.
 - Please setup the display format as 16:9 (wide) aspect ratio type on your DVD player.
-  *Image is too small or too large*
- Turn the zoom lever clockwise or counterclockwise to increase or decrease the projected image size. (Please see page 18).
 - Move the projector closer to or further from the screen.
 - Press "Menu" on the projector panel, go to "Display → Aspect Ratio". Try the different settings.
-  *Image has slanted sides:*
- If possible, reposition the projector so that it is centered on the screen and below the bottom of the screen.
-  *Image is reversed*
- Select "Display → Projection Orientation" from the OSD and adjust the projection direction.

ADDITIONAL INFORMATION

Other problems

 *The projector stops responding to all controls*

- If possible, turn off the projector, then unplug the power cord and wait at least 20 seconds before reconnecting power.

Remote control problems

 *If the remote control does not work*

- Check the operating angle of the remote control is pointed within $\pm 15^\circ$ to the IR receiver on the projector.
- Make sure there are not any obstructions between the remote control and the projector. Move to within 6 m (19.7 ft) of the projector.
- Make sure batteries are inserted correctly.
- Replace batteries if they are exhausted.

ADDITIONAL INFORMATION

Warning indicators

When the warning indicators (see below) light up or flash, the projector will automatically shutdown:

- “Lamp” LED indicator is lit red and if “Power” indicator flashes red.
- “Temp” LED indicator is lit red and if “Power” indicator flashes red. This indicates the projector has overheated. Under normal conditions, the project can be switched back on.
- “Temp” LED indicator flashes red and if “Power” indicator flashes red.

Unplug the power cord from the projector, wait for 30 seconds and try again. If the warning indicator light up or flash, please contact your nearest service center for assistance.

LED lightning messages

| Message | Power LED | | Temp LED | Lamp LED |
|-------------------------------------|--------------|--------------|--------------|--------------|
| | (Red) | (Blue) | (Red) | (Red) |
| Standby state (Input power cord) | Steady light | | | |
| Power on and Lamp lighting | | Steady light | | |
| Error (Lamp failure) | Flashing | | | Steady light |
| Error (Fan failure) | Flashing | | Flashing | |
| Error (Over temp.) | Flashing | | Steady light | |

- Power off:

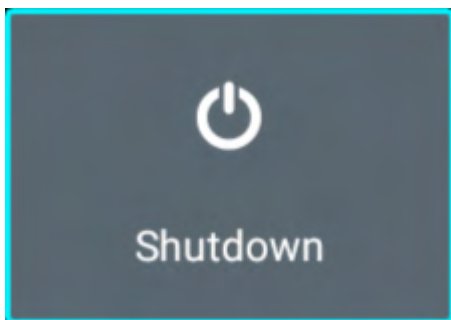

- Temperature warning:

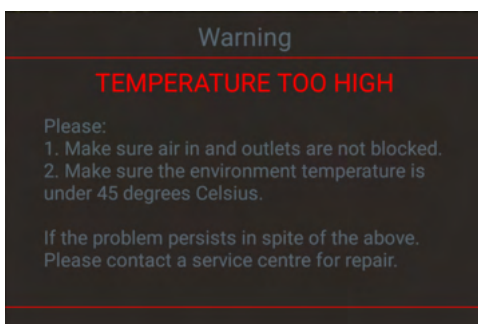

ADDITIONAL INFORMATION

Specifications

| Item | Description |
|---------------------------|---|
| Native resolution | 4K UHD (3840x2160 w/ Actuator) |
| Maximum resolution | 3840x2160@60Hz (HDMI 2.0) |
| Lens | <ul style="list-style-type: none">• Throw ratio: 1.21 ~ 1.59• F-stop: 1.94 ~ 2.23• Focal length: 12.81 ~ 16.74 mm• Zoom range: 1.3x |
| Offset | 105% ±5% |
| Image size | 28" ~ 300" (Mechanism travel; Optimized@82") |
| Projection distance | 1000mm@28" ~ 8000mm@300" |
| I/Os | <ul style="list-style-type: none">• HDMI 2.0 x2• USB Type-A x1 (for Power USB 5V/1.5A and FW upgrade)• 12V Trigger x1 (DC output; 3.5mm jack female; 12V/0.5A max.)• Audio Out x1 (3.5mm jack; female; black)• RS232 x1 (Male (9-Pin D-sub) type) |
| Colour | 1073.4 Million color |
| Scan rate | <ul style="list-style-type: none">• Horizontal scan rate: 15 ~ 255 KHz• Vertical scan rate: 24 ~ 240 Hz |
| Speaker | 15W x1 |
| Power consumption | <ul style="list-style-type: none">• Minimum: (ECO mode) 85 W (typical), 98 W (max.) @110VAC 83 W (typical), 96 W (max.) @220VAC• Maximum: (Bright mode) 150 W (typical), 173 W (max.) @110VAC 148 W (typical), 170 W (max.) @220VAC |
| Input current | 19.5Vdc, 9.23A; 1.60A ,110Vac |
| Installation orientations | Front, Rear, Ceiling, Rear-top |
| Dimensions (W x D x H) | <ul style="list-style-type: none">• Without feet: 274 x 215.5 x 101 mm (10.8 x 8.5 x 4.0 inches)• With feet: 274 x 215.5 x 114 mm (10.8 x 8.5 x 4.5 inches) |
| Weight | 3.4kg ±0.5kg |
| Environmental | Operating in 0~40°C, 10% to 80% humidity (non-condensing) |
| Altitude | <ul style="list-style-type: none">• Operating 0~2,500 ft., for 0°C~40°C 2,500~5,000 ft., for 0°C~35°C 5,000~10,000 ft., for 0°C~30°C• Non-Operating < 40,000 ft. |

Note: All specifications are subject to change without notice.



ADDITIONAL INFORMATION

Optoma global offices

For service or support, please contact your local office.



USA

Optoma Technology, Inc.
47697 Westinghouse Drive.
Fremont, Ca 94539

 888-289-6786
 510-996-4794
 services@optoma.com



Canada

Optoma Technology, Inc.
47697 Westinghouse Drive.
Fremont, Ca 94539

 888-289-6786
 510-996-4794
 services@optoma.com



Latin America

Optoma Technology, Inc.
47697 Westinghouse Drive.
Fremont, Ca 94539

 888-289-6786
 510-996-4794
 services@optoma.com



Europe

1 Bourne End Mills
Hemel Hempstead
Hertfordshire
HP1 2UJ
United Kingdom
www.optoma.eu
Service Tel : +44 (0)1923 691865

 +44 (0) 1923 691 800
 +44 (0) 1923 691 888
 service@tsc-europe.com



Benelux BV

Optoma Benelux BV
Europalaan 770 D
1363BM Almere
The Netherlands
www.optoma.nl

 +31 (0) 36 8200 250
 +31 (0) 36 548 9052



France

Bâtiment E
81-83 avenue Edouard Vaillant
92100 Boulogne Billancourt, France

 +33 1 41 46 12 20
 +33 1 41 46 94 35
 savoptoma@optoma.fr



Spain

C/ José Hierro, 36 Of. 1C 28529 Rivas
Vaciamadrid, Spain

 +34 91 499 06 06
 +34 91 670 08 32



Deutschland

Optoma Deutschland GmbH
Am Nordpark 3
41069 Mönchengladbach
Deutschland

 +49 (0) 2161 68643 0
 +49 (0) 2161 68643 99
 info@optoma.de

Scandinavia

Postboks 9515 Åskollen
Kriveveien 29
Drammen
3036
Norway

 +47 32 98 89 90
 +47 32 98 89 99
 info@optoma.no

Korea

<https://www.optoma.com/kr/>

Japan



<https://www.optoma.com/jp/>

Taiwan

<https://www.optoma.com/tw/>

China

701, 7F, Building 1,
No.1388 Kaixuan Road,
Changning District
Shanghai, 200052, China

 +86-21-62947376
 +86-21-62947375
www.optoma.com.cn

Australia

<https://www.optoma.com/au/>

