

DiGiTech
The Power to Create



HYPER PHASE STEREO PHASER

DECLARATION OF CONFORMITY

Manufacturer's Name: DigiTech
Manufacturer's Address: 8760 S. Sandy Parkway
Sandy, Utah 84070, USA

declares that the product:

Product name: Hyper Phase
Product option: all (requires Class II power
adapter that conforms to the
requirements of EN60065,
EN60742, or equivalent.)

conforms to the following Product Specifications:

Safety: IEC 60065 (1998)

EMC: EN 55013 (1990)
EN 55020 (1991)

Supplementary Information:

The product herewith complies with the requirements of the
Low Voltage Directive 72/23/EEC and the EMC Directive
89/336/EEC as amended by Directive 93/68/EEC.

Vice-President of Engineering
8760 S. Sandy Parkway
Sandy, Utah 84070, USA
Date: May 30, 2002

European Contact: Your local DigiTech Sales and
Service Office or

Harman Music Group
8760 South Sandy Parkway
Sandy, Utah
84070 USA
Ph: (801) 566-8800
Fax: (801) 568-7583

Warning

For your protection, please read the following:

Important Safety Instructions

1. Read these instructions.
2. Keep these instructions.
3. Heed all warnings.
4. Do not use this apparatus near water.
5. Clean only with dry cloth.
6. Do not block any ventilation openings. Install in accordance with the manufacturer's instructions.
7. Do not install near any heat sources such as radiators, heat registers, stoves, or other apparatus (including amplifiers) that produce heat.
8. Protect the power cord from being walked on or pinched particularly at plugs, convenience receptacles, and the point where they exit from the apparatus.
9. Unplug this apparatus during lightning storms or when unused for long periods of time.
10. No user serviceable parts inside. Refer all servicing to qualified service personnel. Servicing is required when the apparatus has been damaged in any way, such as power-supply cord or plug is damaged; liquid has been spilled or objects have fallen into the apparatus; the apparatus has been exposed to rain or moisture, does not operate normally, or has been dropped.
11. **WARNING:** To reduce the risk of fire or electric shock, do not expose this apparatus to rain or moisture.
12. Refer to labels on the unit, including bottom cover, or other markings and pertinent information.

WARRANTY: We at **DigiTech** are proud of our products and back-up each one with the following warranty:

1. The warranty registration card must be mailed within ten days after purchase date to validate this warranty.
2. DigiTech warrants this product, when used solely within the U.S., to be free from defects in materials and workmanship under normal use and service.
3. DigiTech liability under this warranty is limited to repairing or replacing defective materials that show evidence of defect, provided the product is returned to DigiTech WITH RETURN AUTHORIZATION, where all parts and labor will be covered up to a period of **one** year (this warranty is extended to a period of **six** years when the product has been properly registered by mail or through our website). A Return Authorization number may be obtained from DigiTech by telephone. The company shall not be liable for any consequential damage as a result of the product's use in any circuit or assembly.
4. Proof-of-purchase is considered to be the burden of the consumer.
5. DigiTech reserves the right to make changes in design, or make additions to, or improvements upon this product without incurring any obligation to install the same on products previously manufactured.
6. The consumer forfeits the benefits of this warranty if the product's main assembly is opened and tampered with by anyone other than a certified DigiTech technician or, if the product is used with AC voltages outside of the range suggested by the manufacturer.
7. The foregoing is in lieu of all other warranties, expressed or implied, and DigiTech neither assumes nor authorizes any person to assume any obligation or liability in connection with the sale of this product. In no event shall DigiTech or its dealers be liable for special or consequential damages or from any delay in the performance of this warranty due to causes beyond their control.

NOTE: The information contained in this manual is subject to change at any time without notification. Some information contained in this manual may also be inaccurate due to undocumented changes in the product or operating system since this version of the manual was completed. The information contained in this version of the owner's manual supersedes all previous versions.

The Hyper Phase is a multi-function phaser pedal that offers seven different types of phasing effects and CIT™ cabinet modeling. The following sections outline how the knobs and pedal functions work.

1. Speed Knob

Controls the speed of the phase shift sweep. Turn this knob clockwise to increase the speed, and counter-clockwise to decrease the speed.

2. Depth Knob

Controls the depth of the phase shift effect. Turn this knob clockwise to increase the depth, and counter-clockwise to decrease the depth.

3. AC Adapter Jack

Connect a DigiTech PS200R (9VDC output) power supply to this jack. Use the proper supply for your area's Mains line voltage.

4. Regen Knob

Controls the amount of regeneration (feedback) in the phaser effect. Turn this knob clockwise to increase the regeneration, and counter-clockwise to decrease the regeneration. When **4-RISE/FALL** is selected, this knob creates a rising sweep when set between the minimum and 12 o'clock positions, and a falling sweep when set between the 12 o'clock and maximum positions.

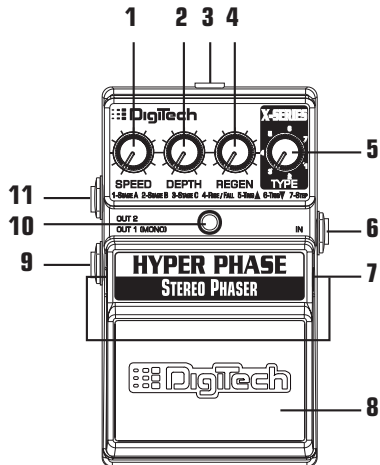

5. Type Knob

Selects 1 of the 7 different phaser effect types.

1-STAGE A - A 4 stage phase shifter.

2-STAGE B - An 8 stage phase shifter.

3-STAGE C - A 12 stage phase shifter.

4-RISE / FALL - Creates a constant rising phaser sound when the **REGEN** knob is set between the minimum and 12 o'clock positions, or a constant falling phaser sound when the **REGEN** knob is set between the 12 o'clock and maximum positions.

5-TRIG UP* - The phaser effect starts at the bottom of its sweep when the trigger threshold is reached. Use the **REGEN** knob to adjust the trigger threshold sensitivity and **SPEED** knob to adjust sweep rate. Regeneration is fixed when Triggered Up is selected.

6-TRIG DOWN* - The phaser effect starts at the top of its sweep when the trigger threshold is reached. Use the **REGEN** knob to adjust the trigger threshold sensitivity and **SPEED** knob to adjust sweep rate. Regeneration is fixed when Triggered Down is selected.

7-STEP - Creates a random square wave phase effect similar to a sample and hold filter on a synthesizer.

* Using a distortion pedal before the Hyper Phase may cause inconsistent triggering due to the non-dynamic nature of distorted signals.

6. Input Jack

Connect your instrument to this jack. Connecting a guitar cable to this jack supplies battery power even though the Indicator LED may not be lit. To prolong battery life, disconnect all cables from the pedal when not in use.

7. Pedal Release Pins

These two pins are spring-loaded hinges that hold the pedal in place. Push these pins in to release the pedal from the pedal chassis exposing the battery compartment. (See battery replacement diagram).

8. Pedal

Press the pedal to turn the effect on and off.

9. Out 1 (Mono) Jack

Connect this output to a single guitar amplifier or mixer channel when only one amp or mixer channel is being used.

10. Indicator LED

This LED indicates when the effect is turned on. If the LED becomes dim or does not light when the cables are connected, the battery needs to be replaced.

11. Out 2 Jack

Connect this output to a second amplifier or mixer channel for stereo phasing. Stereo is the best way to get the most effective stereo phaser experience from the Hyper Phase pedal.

Connections

The Hyper Phase has a single input and a pair of outputs. **Out 1** is used if the Hyper Phase is being connected to only one amplifier or mixer channel panned center. **Out 2** is used for stereo operation. Connect **Out 1** to the first amplifier or mixer channel panned left and **Out 2** to the second amplifier or mixer channel panned right.

The Hyper Phase also has built-in CIT™ cabinet modeling that can be enabled. This is a useful tool when running a distortion pedal into the Hyper Phase and then running direct into a mixer or recorder. CIT creates a guitar-through-an-amplifier sound without having to use a guitar amp.

To Enable CIT™ Cabinet Modeling:

Press the pedal down and apply power (connect a guitar cable to the Hyper Phase input or connect the PS200R power supply to the AC adapter jack). CIT™ cabinet modeling has to be turned on each time you apply power to the Hyper Phase.

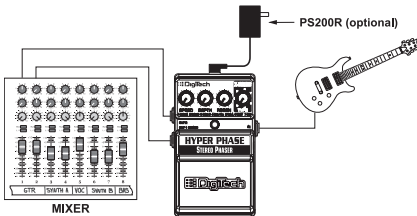
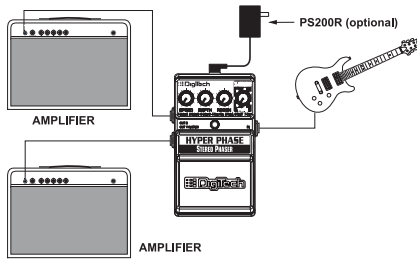

Battery Replacement

1. Using the tip of a 1/4" guitar cable, push one of the release pins in on either side of the pedal, and remove the pedal from the pedal chassis.
2. Remove the battery from the battery compartment and disconnect the battery cable.
3. Connect a new battery to the battery cable and put it back in the battery compartment. Make sure the battery cable does not interfere with the spring or pedal switch arm.
4. Place one hole of the pedal over its corresponding pin.
5. Push the opposite pin in and lower the other side of the pedal into place over the depressed pin. Release the pin. When the pedal is properly fastened, both release pins are flush with the outer side of the pedal.

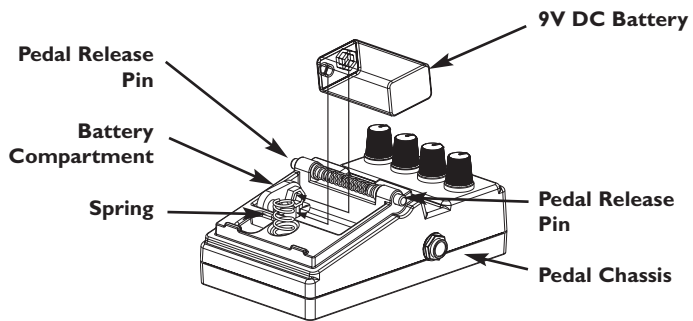
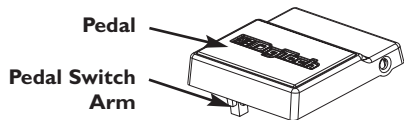

SPECIFICATIONS:

- Controls - Speed, Depth, Regen, Type, On/Off Pedal
- Jacks - Input, Out 1 (Mono), Out 2
- Input Impedance - 1 MOhms
- Output Impedance - 100 Ohms
- Power Supply - 9V Alkaline Dry Battery
- Power Consumption - 4.8Watts (w/optional PS200R power supply)
- Battery Life - Approximately 4 hours (with continuous usage)
- Dimensions - 4 15/16"(L) x 3 1/8"(W) x 2 1/8"(H)
- Weight - 1.38 lbs.
- Optional Power Supply
 - PS200R - 100 (100V ~ 50/60Hz)
 - PS200R - 120 (120V ~ 60Hz)
 - PS200R - 230 (230V ~ 50Hz)
 - PS200R - 240 (240V ~ 50Hz)

DigiTech
8760 South Sandy Parkway
Sandy, Utah 84070
PH (801) 566-8800
FAX (801) 566-7005

DigiTech and X-Series are trademarks
of the Harman Music Group Inc.

Copyright - Harman Music Group

Hyper Phase Stereo Phaser
Owners Manual 18-1806V-A

Please visit DigiTech
on the World Wide Web at:
www.digitech.com

Printed in China

 A Harman International Company