

# *Ampeg*

## **PF-20T and PF-50T Bass Guitar Amplifiers**

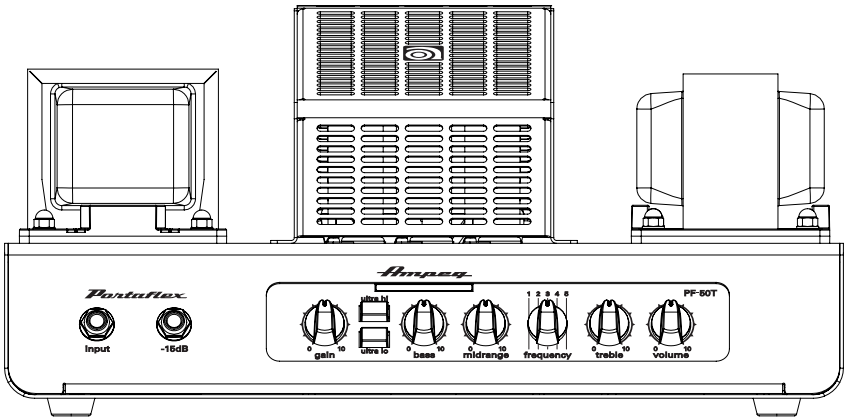

## **Owner's Manual**

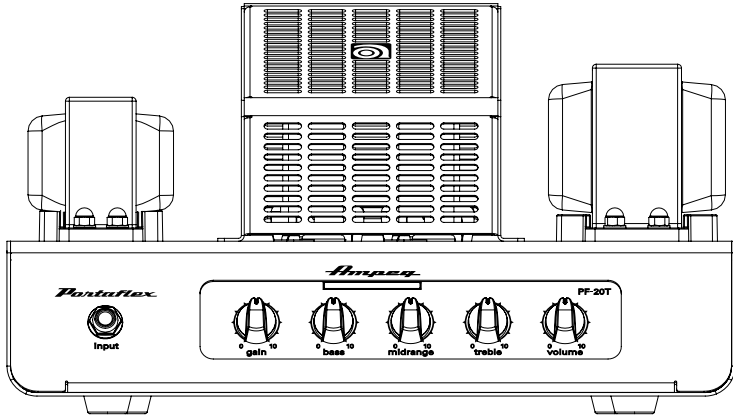

## IMPORTANT SAFETY INSTRUCTIONS

1. Read these instructions.
2. Keep these instructions.
3. Heed all warnings.
4. Follow all instructions.
5. Do not use this apparatus near water.
6. Clean only with a dry cloth.
7. Do not block any ventilation openings. Install in accordance with the manufacturer's instructions.
8. Do not install near any heat sources such as radiators, heat registers, stoves, or other apparatus (including amplifiers) that produce heat.
9. Do not defeat the safety purpose of the polarized or grounding-type plug. A polarized plug has two blades with one wider than the other. A grounding-type plug has two blades and a third grounding prong. The wide blade or the third prong are provided for your safety. If the provided plug does not fit into your outlet, consult an electrician for replacement of the obsolete outlet.
10. Protect the power cord from being walked on or pinched particularly at plugs, convenience receptacles, and the point where they exit from the apparatus.
11. Only use attachments/accessories specified by the manufacturer.
12. Use only with a cart, stand, tripod, bracket, or table specified by the manufacturer, or sold with the apparatus. When a cart is used, use caution when moving the cart/apparatus combination to avoid injury from tip-over.



**WARNING** — To reduce the risk of fire or electric shock, do not expose this apparatus to rain or moisture.

Laite on liitettävä suojakoskettimilla varustettuun pistorasiaan.

Apparatet må tilkoples jordet stikkontakt.

Apparaten skall anslutas till jordat uttag.

13. Unplug this apparatus during lightning storms or when unused for long periods of time.
14. Refer all servicing to qualified service personnel. Servicing is required when the apparatus has been damaged in any way, such as power-supply cord or plug is damaged, liquid has been spilled or objects have fallen into the apparatus, the apparatus has been exposed to rain or moisture, does not operate normally, or has been dropped.
15. This apparatus shall not be exposed to dripping or splashing, and no object filled with liquids, such as vases or beer glasses, shall be placed on the apparatus.
16. Do not overload wall outlets and extension cords as this can result in a risk of fire or electric shock.
17. This apparatus has been designed with Class-I construction and must be connected to a mains socket outlet with a protective earthing connection (the third grounding prong).
18. The MAINS plug or an appliance coupler is used as the disconnect device, so the disconnect device shall remain readily operable.
19. For the terminals marked with symbol of “⚡” may be of sufficient magnitude to constitute a risk of electric shock. The external wiring connected to the terminals requires installation by an instructed person or the used of ready-made leads or cords.

	<b>CAUTION</b>	
RISK OF ELECTRIC SHOCK! DO NOT OPEN!		
CAUTION: TO REDUCE THE RISK OF ELECTRIC SHOCK DO NOT REMOVE COVER (OR BACK). NO USER-SERVICEABLE PARTS INSIDE. REFER SERVICING TO QUALIFIED PERSONNEL.		

The lightning flash with arrowhead symbol within an equilateral triangle means "electric shock hazard". It is intended to alert the user to the presence of uninsulated "dangerous" voltage within the product enclosure, that may be of significant magnitude to constitute a risk of electric shock to persons.

The exclamation point within an equilateral triangle means "Warning/Caution!". It is intended to alert the user of the presence of important operating and maintaining (servicing) instructions in the literature accompanying the appliance.



**NOTE:** This equipment has been tested and found to comply with the limits for a Class B digital device, pursuant to part 15 of the FCC Rules. These limits are designed to provide reasonable protection against harmful interference in a residential installation. This equipment generates, uses, and can radiate radio frequency energy and, if not installed and used in accordance with the instructions, may cause harmful interference to radio communications. However, there is no guarantee that interference will not occur in a particular installation. If this equipment does cause harmful interference to radio or television reception, which can be determined by turning the equipment off and on, the user is encouraged to try to correct the interference by one or more of the following measures:

- Reorient or relocate the receiving antenna.
- Increase the separation between the equipment and the receiver.
- Connect the equipment into an outlet on a circuit different from that to which the receiver is connected.
- Consult the dealer or an experienced radio/TV technician for help.

**CAUTION:** Changes or modifications to this device not expressly approved by LOUD Technologies Inc. could void the user's authority to operate the equipment under FCC rules.

This apparatus does not exceed the Class A/Class B (whichever is applicable) limits for radio noise emissions from digital apparatus as set out in the radio interference regulations of the Canadian Department of Communications.

Exposure to extremely high noise levels may cause permanent hearing loss. Individuals vary considerably in susceptibility to noise-induced hearing loss, but nearly everyone will lose some hearing if exposed to sufficiently intense noise for a period of time. The U.S. Government's Occupational Safety and Health Administration (OSHA) has specified the permissible noise level exposures shown in the following chart.

According to OSHA, any exposure in excess of these permissible limits could result in some hearing loss. To ensure against potentially dangerous exposure to high sound pressure levels, it is recommended that all persons exposed to equipment capable of producing high sound pressure levels use hearing protectors while the equipment is in operation. Ear plugs or protectors in the ear canals or over the ears must be worn when operating the equipment in order to prevent permanent hearing loss if exposure is in excess of the limits set forth here:

Duration, per day in hours	Sound Level dBA, Slow Response	Typical Example
8	90	Duo in small club
6	92	
4	95	Subway train
3	97	
2	100	Very loud classical music
1.5	102	
1	105	The boss screaming at his minions about manual deadlines
0.5	110	
0.25 or less	115	Loudest parts of a rock concert



**Correct disposal of this product:** This symbol indicates that this product should not be disposed of with your household waste, according to the WEEE directive (2012/19/EU) and your national law. This product should be handed over to an authorized collection site for recycling waste electrical and electronic equipment (EEE). Improper handling of this type of waste could have a possible negative impact on the environment and human health due to potentially hazardous substances that are generally associated with EEE. At the same time, your cooperation in the correct disposal of this product will contribute to the effective usage of natural resources. For more information about where you can drop off your waste equipment for recycling, please contact your local city office, waste authority, or your household waste disposal service.



**TABLE OF CONTENTS**

Important Safety Instructions .....	2-3
Table Of Contents .....	4
Introduction .....	4
PortaFlex Series Features .....	5
PortaFlex Series Front Panel Features .....	6
PortaFlex Series Rear Panel Features .....	7-8
Some Suggested Settings .....	9
Favorite Settings.....	10
Changing the Tubes .....	11
Setting Tube Bias.....	12
PF-20T Technical Specifications and Block Diagram .....	13
PF-50T Technical Specifications and Block Diagram .....	14
Service Information .....	15

**Introduction**

The Portaflex series bass amplifiers brought legendary Ampeg tone in powerful lightweight design that bass players around the world, from beginners to professionals, have made the most popular bass amplifiers in history. The PF-20T and PF-50T deliver legendary Ampeg all-tube tone and warmth in the same portable, powerful and affordable design.

Designed to be compact and match perfectly with existing Portaflex cabinets, the PF-20T and PF-50T are perfect for small to medium sized shows, studio recording or even a rehearsal studio. Combined with the PF-112HLF compact cabinet, you have the ultimate portable tone powerhouse.

Like all Ampeg products, your Portaflex series bass amplifier is designed by musicians and built using only the best of components. Each amp is tested to confirm that it meets our specifications, and we believe that this amp is the absolute best that it can be.

In order to get the most out of your new amp, please read this manual before you begin playing. Best of luck in all of your musical endeavors!

And **thank you** for choosing Ampeg.



**PortaFlex PF-20T / PF-50T Features:**

- RMS power output:  
20W @ 4 or 8 ohms [PF-20T]  
50W @ 4 or 8 ohms [PF-50T]
- Preamp: All-tube 2 x 12AX7
- Power amp:  
All-tube 2 x 6V6 [PF-20T]  
All-tube 1 x 12AU7, 2 x 6L6 [PF-50T]
- 0 dB and -15 dB inputs [PF-50T]
- Tone controls: Bass, Mid, Treble
- Mid-tone control: 5-position [PF-50T]
- Ultra Hi/Lo boosts [PF-50T]
- Input gain control
- Preamp balanced line out
  - Pre/Post EQ
  - Ground lift
- Transformer balanced line out
  - Ground lift
- No speaker load required
- User-adjustable bias control
- Dimensions:  
7.3 x 13.0 x 10.4 in / 185 x 330 x 264 mm [PF-20T]  
7.3 x 13.9 x 10.4 in / 185 x 353 x 264 mm [PF-50T]
- Weight:  
15.2 lb / 6.9 kg [PF-20T]  
19.4 lb / 8.8 kg [PF-50T]



## PortaFlex Series Front Panel Features

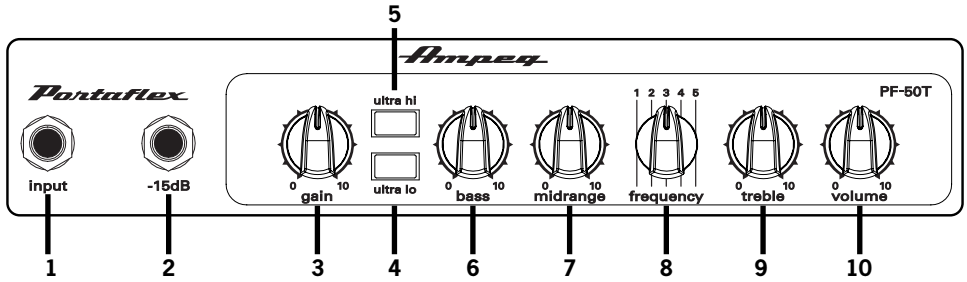

- 1. PF-20T INPUT:** The signal output from an instrument (active or passive) may be connected to this 1/4" input by means of a shielded instrument cable.
- PF-50T INPUT:** The signal output from a passive instrument may be connected to this 1/4" input by means of a shielded instrument cable.
- 2. -15 dB INPUT:** The signal output from an active instrument may be connected to this 1/4" input by means of a shielded instrument cable. [PF-50T]
- 3. GAIN:** This control adjusts the input level of signal reaching the preamp.
- 4. ULTRA LO:** This switch, when engaged, emphasizes the lows by +2 dB at 50 Hz and -10 dB at 500Hz. [PF-50T]
- 5. ULTRA HI:** This switch, when engaged, enhances the amount of high frequency output by +5 dB @ 8 kHz. [PF-50T]
- 6. BASS:** Use this to adjust the low frequency level of the amplifier. The low frequency output is flat at the center position. See pages 13-14 for technical specifications.
- 7. MID:** Use this to adjust the midrange frequency level of the amplifier. The midrange frequency output is flat at the center position. Rotate the control counter clockwise for a "contoured" sound (more distant, less midrange output) or clockwise for a sound which really cuts through. See pages 13-14 for technical specifications.
- 8. FREQUENCY:** This control allows you to select the center frequency for the midrange control, giving you a choice of five "voices" for the midrange. The numbers correspond to the following center frequencies: 1=200 Hz, 2=400 Hz, 3=800 Hz, 4=1.6 kHz, 5=3 kHz. [PF-50T]
- 9. TREBLE:** Use this to adjust the high frequency level of the amplifier. The high frequency output is flat at the center position. See pages 13-14 for technical specifications.
- 10. VOLUME:** Use this to control the overall output level. It affects the speaker outputs and the preamp output. Use it wisely, and turn it down when making connections or trying something new.



## PortaFlex Series Rear Panel Features

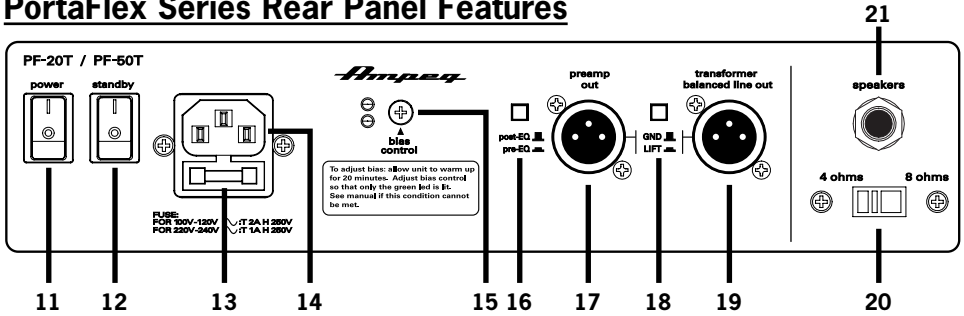

**11. POWER SWITCH:** Use this switch to turn the overall system power on or off. Press the top of the switch to turn on the power. The power switch should be engaged prior to the standby switch (as mentioned below, #12).

**12. STANDBY SWITCH:** Use this switch to turn the standby power on or off. Press the top of the switch to disengage the standby circuit [ON position]. The Standby mode allows the tubes to warm or remain warm without high voltage being applied to them. This extends tube life. This switch should be OFF when first turning the amplifier on. Allow the unit to warm up for at least 20 seconds before switching to the ON position. During short periods of non-use, the amp should be put into Standby mode.

**13. FUSE:** This protects the unit from damage due to overload conditions or power line surges. If the fuse blows, replace it only with the same size and type.

**14. IEC POWER INPUT CONNECTOR:** This is where you connect the supplied AC power cord. Plug the male end of the cord into a grounded AC outlet.

 DO NOT DEFEAT THE GROUND PRONG OF THE AC PLUG!

**15. BIAS SECTION:** This control and set of LEDs allow the user to properly bias the power amp. See “Setting Tube Bias” on page 12 for a complete description of how to use this section.

**16. POST-EQ/PRE-EQ:** The signal at the preamp out can be set to either Pre-EQ or Post-EQ with this switch. With the switch in the IN position, the signal at the preamp out is Pre-EQ. This is a direct output not affected by any EQ or boost settings. With the switch in the OUT position, the signal is Post-EQ and is controlled and modified by the tone controls.

**17. PREAMP OUT:** This signal may be used to feed an external power amplifier, mixing console, interface or house PA system.

The lift/gnd switch [18] is available to reduce any noise that may occur.

**18. LIFT / GND:** When this switch is engaged, it connects the ground connection to help reduce residual hum and buzz sometimes picked up in the signal cables.

**19. TRANSFORMER BAL OUT:** This signal may be used to feed an external power amplifier, mixing console, interface or house PA system.

The lift/gnd switch [18] is available to reduce any noise that may occur.



### PortaFlex Series Rear Panel Features Continued...

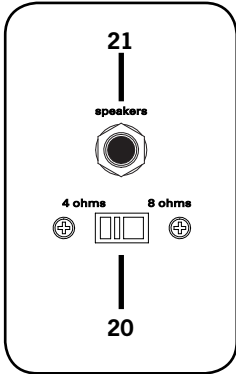

**20. IMPEDANCE SELECTOR:** Use this switch to match the output impedance of the amp to the speaker(s) being used (4 or 8 ohms).

For help in deciding the total impedance of your system, consult the chart below.

Cabinet Impedance	Number of Cabinets	Total Impedance
2 ohms	1	2 ohms
4 ohms	1	4 ohms
4 ohms	2	2 ohms
8 ohms	2	4 ohms
8 ohms	4	2 ohms

**21. SPEAKER OUTPUT:** This mono 1/4" TS output jack supplies speaker-level power to the speaker cabinet. The rated power output is 20 watts rms [PF-20T] or 50 watts rms [PF-50T] into 4 or 8 ohms.

Make sure the total speaker impedance load is 4 ohms or greater.

For example, you could connect:

2 16 ohm speakers in parallel = 8 ohms

2 8 ohm speakers in parallel = 4 ohms

Use speaker cables with 1/4" TS ends to make the connections. Do not use instrument cables as they may overheat.

**NOTE:** Unlike many tube heads which require a load (speaker) be attached for operation, the PF-50T / PF-20T may be operated with or without a speaker load attached.

This is extremely useful for direct recording or bypassing a speaker entirely in a live setting. This is also useful should the speaker become disconnected during performance, as the amplifier will not be harmed.





**Some Suggested Settings**

**JAZZ:**

Diagram showing suggested settings for Jazz. The controls are: gain (0 to 10), ultra hi (0 to 10), ultra lo (0 to 10), bass (0 to 10), midrange (0 to 10), frequency (1 to 5), treble (0 to 10), and volume (0 to 10). The gain knob is set to approximately 5. The ultra hi and ultra lo knobs are set to approximately 5. The bass knob is set to approximately 5. The midrange knob is set to approximately 5. The frequency knob is set to 3. The treble knob is set to approximately 5. The volume knob is set to approximately 5. An 'IN' button is located below the ultra hi and ultra lo knobs.

**FUNK:**

Diagram showing suggested settings for Funk. The controls are: gain (0 to 10), ultra hi (0 to 10), ultra lo (0 to 10), bass (0 to 10), midrange (0 to 10), frequency (1 to 5), treble (0 to 10), and volume (0 to 10). The gain knob is set to approximately 5. The ultra hi knob is set to approximately 5. The ultra lo knob is set to approximately 5. The bass knob is set to approximately 5. The midrange knob is set to approximately 5. The frequency knob is set to 3. The treble knob is set to approximately 5. The volume knob is set to approximately 5. An 'IN' button is located above the ultra hi and ultra lo knobs.

The setting of the Gain control depends on your particular instrument.

The Volume should be set to produce the appropriate output.

**ROCK:**

Diagram showing suggested settings for Rock. The controls are: gain (0 to 10), ultra hi (0 to 10), ultra lo (0 to 10), bass (0 to 10), midrange (0 to 10), frequency (1 to 5), treble (0 to 10), and volume (0 to 10). The gain knob is set to approximately 5. The ultra hi knob is set to approximately 5. The ultra lo knob is set to approximately 5. The bass knob is set to approximately 5. The midrange knob is set to approximately 5. The frequency knob is set to 3. The treble knob is set to approximately 5. The volume knob is set to approximately 5.

**FACE MELTER:**

Diagram showing suggested settings for Face Melter. The controls are: gain (0 to 10), ultra hi (0 to 10), ultra lo (0 to 10), bass (0 to 10), midrange (0 to 10), frequency (1 to 5), treble (0 to 10), and volume (0 to 10). The gain knob is set to approximately 5. The ultra hi knob is set to approximately 5. The ultra lo knob is set to approximately 5. The bass knob is set to approximately 5. The midrange knob is set to approximately 5. The frequency knob is set to 3. The treble knob is set to approximately 5. The volume knob is set to approximately 5.



**Favorite Settings**

0 gain 10    ultra hi    0 bass 10    0 midrange 10    1 2 3 4 5 frequency    0 treble 10    0 volume 10

ultra lo

0 gain 10    ultra hi    0 bass 10    0 midrange 10    1 2 3 4 5 frequency    0 treble 10    0 volume 10

ultra lo

0 gain 10    ultra hi    0 bass 10    0 midrange 10    1 2 3 4 5 frequency    0 treble 10    0 volume 10

ultra lo

0 gain 10    ultra hi    0 bass 10    0 midrange 10    1 2 3 4 5 frequency    0 treble 10    0 volume 10

ultra lo

0 gain 10    ultra hi    0 bass 10    0 midrange 10    1 2 3 4 5 frequency    0 treble 10    0 volume 10

ultra lo



## Changing the Tubes

Tubes wear out in direct proportion to how often and how hard you play your amplifier. Power tubes should be checked at least once a year – more frequently if you use the amplifier nearly every day. When power tubes wear out, the amplifier will begin to grow weak, lack punch, fade up and down, or lose highs and lows. Power tubes work together in a push/pull configuration and should be replaced at the same time with matched or balanced tubes. Your dealer can recommend the best replacement tubes for your amplifier.

Preamp tubes aren't worked as hard as power tubes and typically last longer. When a preamp tube wears out, the amplifier may squeal, get noisy, lose gain and sensitivity, or just quit working. A service center can determine which tube(s) may need replacing.

To get to the tubes in the PF-20T / PF-50T, the top screen must be removed first.

**Qualified service persons** may follow these steps to change the tubes:

- Turn the amp off, unplug it and let it cool for at least 5 minutes.
- Remove the screws which hold the perforated metal screen to the top of the chassis [Figure A].
- Set the perforated metal screen aside.
- Using a soft cloth, grasp the **POWER** tube as closely to the base as possible and gently work it out of its socket by rocking it slightly back and forth as you lift up on it [Figure B].

**NOTE:** The retainers at the base may be spread apart to help remove the tube.

**NOTE:** The PF-50T has a 12AU7 Power Tube, but it is removed / attached similarly to the Preamp Tubes (instructions below).

- Using a soft cloth, carefully replace the **POWER** tubes by handling them as closely to the base as possible and firmly pressing down into the tube sockets.

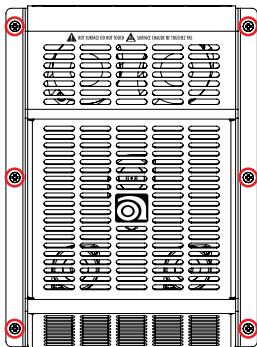

Figure A

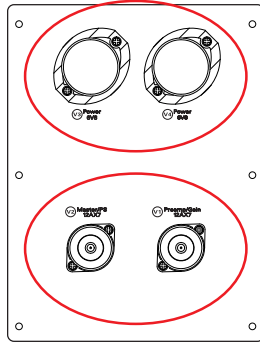

Figure B [PF-20T]

Power Tubes

Preamp Tubes

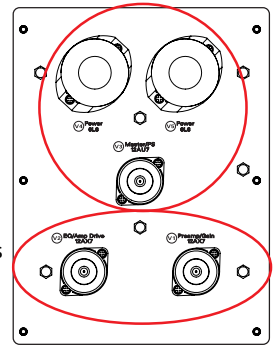

Figure B [PF-50T]

- Grasp the **PREAMP** tube retainer at its top, push down and twist left [counter-clockwise] until the tabs line up with the notches and lift up on it to remove [Figure B].
- Using a soft cloth, grasp the **PREAMP** tube as closely to the base as possible and gently work it out of its socket by rocking it slightly back and forth as you lift up on it.
- Using a soft cloth, carefully replace the **PREAMP** tube by handling it as closely to the base as possible. Line up the connector pins with the socket, then press down into the tube socket to lock the tube into place.
- Replace the perforated metal screen and screws.
- Power up the amplifier and let it sit for at least 20 minutes. Bias the amplifier as directed on the next page.



## Setting Tube Bias

Turn the power on and allow the unit to sit in 'Standby' for 3-5 minutes (after following all normal setup requirements). Next, take the unit out of 'Standby' and do a quick check of the Bias LEDs. One LED should be lit green and the other LED off. If not, turn the Bias control until the LED is lit green. If this seems impossible, please refer to the chart on the next page for possible fault conditions. Now is a good time to check for any unusual sounds and possible glowing from the Power Tubes (see 'Changing the Power Tubes' section listed above).

At this time, play your bass for at least 20 minutes to allow the unit to warm up at proper AC line voltage. You may notice that the other Bias LED illuminates red while playing. This is normal.

Next, turn down all controls on your bass and set it aside, leaving all amp controls alone. With no input signal present, adjust the Bias control so that only the green LED is illuminated.

So where does one set the Bias? If neither LED is lit, the amp is over-biased (counter-clockwise). This will result in some distortion in the power amp and a generally thin sound. If the green and red LEDs are lit, the amp is under-biased (clockwise) and too much current is flowing to the power tubes. This will result in a big, full sound, but will also reduce the life of the power tubes. For the longest tube life, but poorer tone, set the Bias to JUST AS the green LED illuminates. For shorter tube life, but better tone, set the Bias to JUST BEFORE the red LED illuminates.

Once set, the controls should not have to be changed except as needed for tube replacement, or to compensate for tube aging. Note that the AC line voltage may vary from place to place and the LEDs will vary slightly. This is normal.

By observing the LEDs as the Bias control is slowly rotated clockwise, a number of tube problems may be diagnosed by the user as seen in the table below.

**NOTE:** Depending upon the bias setting, the red bias LED may light or flicker when signal is applied to the amp input; this is a normal condition.

Condition	Problem	Solution
Green comes on, then red	No problem	The longer the green LED is on before the red LED comes on, the better matched the tubes are.
Red comes on, then green	Tubes not properly matched	Set slightly before green comes on, obtain matched tubes when possible.
Red comes on, no green	One or more tubes are non-functioning	Check to make sure tubes are all seated properly; if so, find and replace bad tube(s).
None on	Possibly no high voltage or bad Bias Control or bad tube(s)	Have unit checked by a service technician.
Both on all the time	Possible bad Bias Control or bad tubes	Have unit checked by a service technician.



## PF-20T TECHNICAL SPECIFICATIONS

Preamp	All-tube 2 x 12AX7
Power Amp	All-tube 2 x 6V6
Output Power Rating	20 watts @ 8 ohms, 10% THD 20 watts @ 4 ohms, 10% THD
Signal to Noise Ratio	60 dB (20 Hz–20 kHz, unweighted)
Maximum Gain	Input: 54 dB
Tone Controls	Bass: +8/-12 dB @ 50 Hz Midrange: +5/-15 dB @ 550 Hz Treble: +13/-20 dB @ 4 kHz
Power Requirements	120 VAC, 60 Hz, 50W 100 VAC, 50-60 Hz, 50W 220-240 VAC, 50-60 Hz, 50W
Size (H x W x D)	7.3 in x 13.0 in x 10.4 in 185 mm x 330 mm x 264 mm
Weight	15.2 lb / 6.9 kg (approximately)

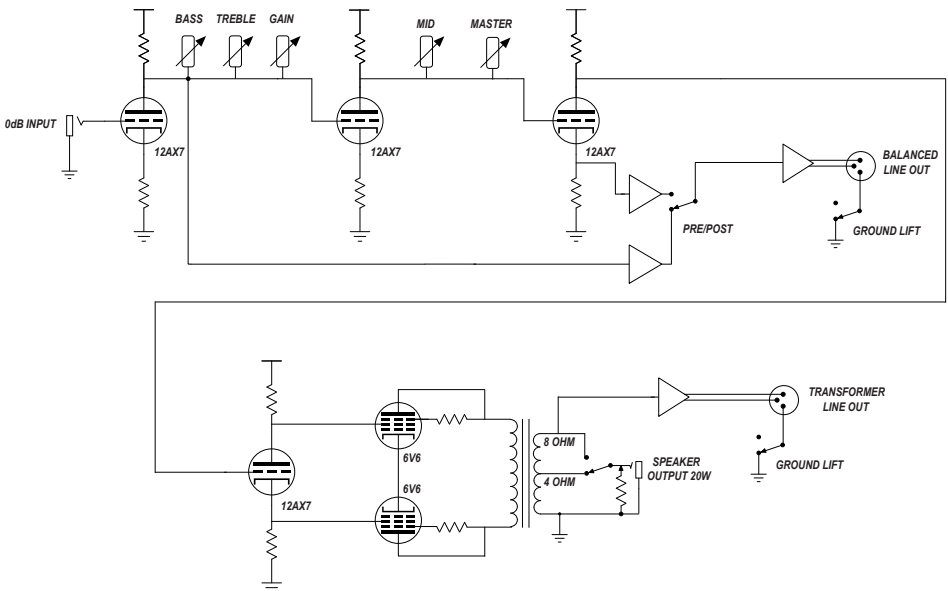



## PF-50T TECHNICAL SPECIFICATIONS

Preamp	All-tube 2 x 12AX7
Power Amp	All-tube 1 x 12AU7, 2 x 6L6
Output Power Rating	50 watts @ 8 ohms, 10% THD 50 watts @ 4 ohms, 10% THD
Signal to Noise Ratio	60 dB (20 Hz–20 kHz, unweighted)
Maximum Gain	Input: 66 dB
Tone Controls	Bass: +10/–10 dB @ 60 Hz Midrange: +5/–20 dB @ 200 Hz, 400 Hz, 800 Hz +5/–15 dB @ 1.6 kHz, 3 kHz Treble: +13/–23 dB @ 4 kHz Ultra Lo: +2 dB @ 50 Hz, –10 dB @ 500 Hz Ultra Hi: +5 dB @ 8 kHz
Power Requirements	120 VAC, 60 Hz, 90W 100 VAC, 50-60 Hz, 90W 220-240 VAC, 50-60 Hz, 90W
Size (H x W x D)	7.3 in x 13.9 in x 10.4 in 185 mm x 353 mm x 264 mm
Weight	19.4 lb / 8.8 kg (approximately)

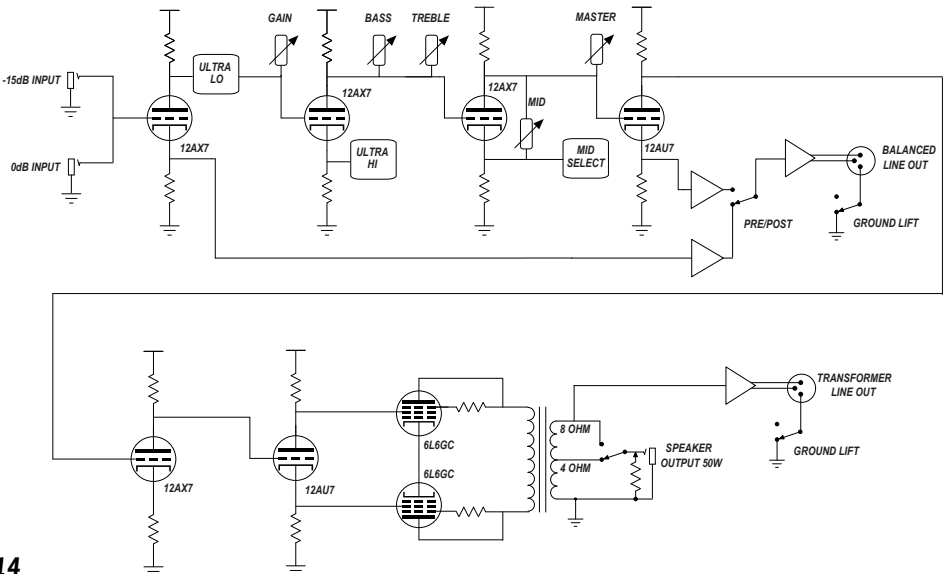



## **Service Information**

If you are having a problem with your PF-series amp, you can go to our website ([www.ampeg.com](http://www.ampeg.com)) and click on Support for service information, or call Technical Support at 1-800-898-3211 Monday-Friday during normal business hours, Pacific Time, to receive assistance. If you are outside of the U.S., contact your local distributor for technical support and service.

**PF-series amps are covered with sheet metal, so be sure to clean it with a dry lint-free cloth. Never spray cleaning agents on the PF-series amps. Avoid abrasive cleansers which would damage the finish.**

*Ampeg continually develops new products and improves upon existing ones. For this reason, the specifications and information in this manual are subject to change without notice.*

*"Ampeg" is a registered trademark of LOUD Technologies Inc. All other brand names mentioned are trademarks or registered trademarks of their respective holders and are hereby acknowledged.*

[www.ampeg.com](http://www.ampeg.com)

©2015 LOUD Technologies Inc.

16220 Wood-Red Road NE • Woodinville, WA 98072

Part No. SW1126 Rev. B 10/15



# PF-20T and PF-50T Bass Guitar Amplifiers

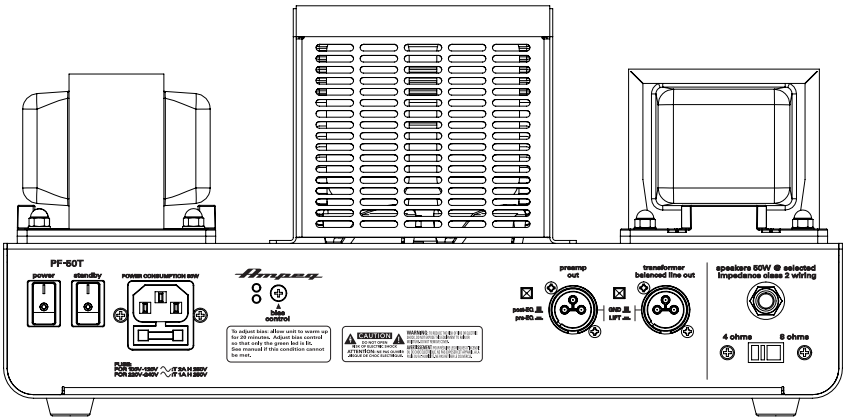
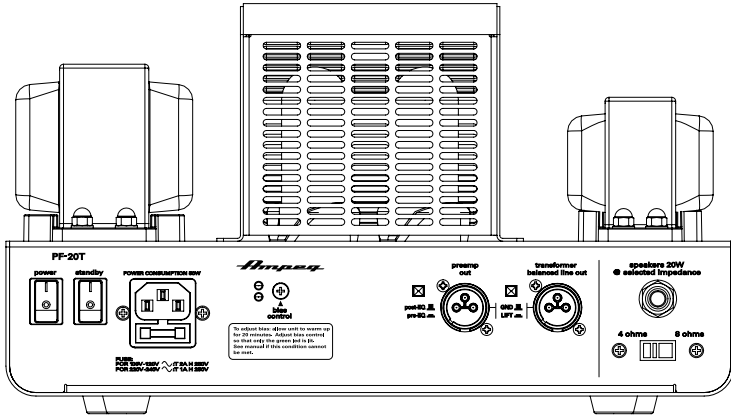

**Owner's Manual**