

PT-6
PEDAL TUNER
Chromatic Tuner
Users Manual



www.nuxefx.com

Thank you for selecting the **nux** PT-6 Pedal Tuner! The result of many years of research allows us to give you great guitar products for your greatest music experience!

Please take the time to read this manual carefully to get the most out of the unit. We recommend that you keep the manual for future reference.

PRODUCT INTERFACE

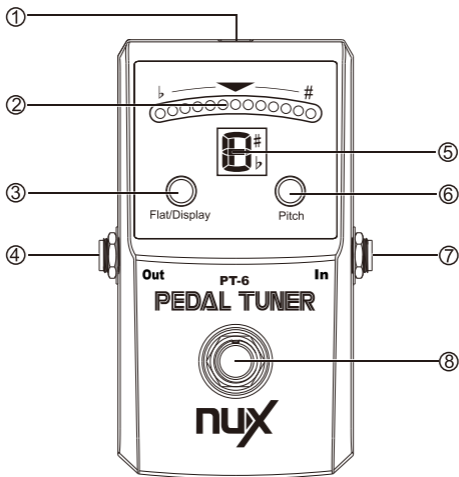

- ① 9V DC Jack
- ② LED Display
- ③ Flat/Display button
- ④ ¼ inch (Mono) OUTPUT Jack
- ⑤ Note Display
- ⑥ Pitch button
- ⑦ ¼ inch (Mono) INPUT Jack
- ⑧ On/Off Switch

FEATURES

- Chromatic tuning mode allows a wide range of tuning options.
- LED display gives you a clearer tuning view.
- Flat tuning and A4 range.
- True Bypass Circuitry to allow you to quickly switch the signal in and out without latency or loss of tone.
- If no signal is present for 5 minutes, it will shut-off automatically.

OPERATION

1. When connected to an audio cable, the PT-6 will go into Bypass mode. Press [On/off Switch] to enter tuning mode as shown in the picture below:

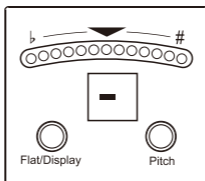

2. Press [Flat/Display] to change the tuning mode display: Normal or strobe.

a) Normal

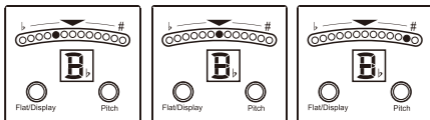

Flat

In tune

Sharp

Flat: Red LED to the left of center lights.

In tune: Green LED in the middle lights.

Sharp: Red LED to the right of center lights.

b) Strobe display

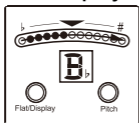

Sharp

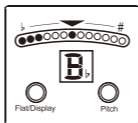

In tune

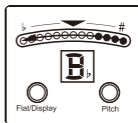

Flat

Flat: LED moves to the left.

In tune: LED stops moving.

Sharp: LED moves to the right.

Notice: When the note is out of tune (sharp or flat), the Strobe moves fast, which means the note is way off. The display will move slower and slower until the note is in tune then it stops!

3.Flat tuning

Press [Flat/Display] quickly to set flat tuning, as shown in picture below:

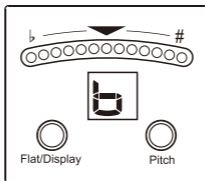

Press [Flat/Display] quickly again to adjust flat tuning range: ♭ ♭♭ ♭♭♭ ♭♭♭♭ .

Release the pedal. The LED will flash for 2 seconds, which means it is ready to enter tuning mode automatically.

One example of Flat tuning ♭♭♭ is shown in picture below:

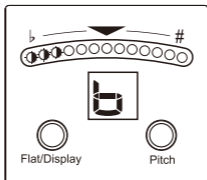

4. Setting A4 range

In tuning mode, press [Pitch] to enter the A4 setting interface. Press [Pitch] again to set A4 from 435~445Hz. The default A4 is 440Hz, as shown in picture below:

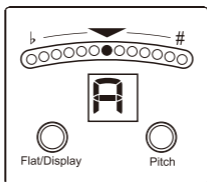

A4 Loop:

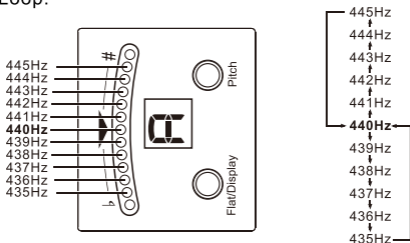

5. Tuning result: C, C[#], D, E^b, E, F, F[#], G, G[#], A, B^b, B.

6. If no signal is present for 5 minutes, it will shut-off automatically. Quickly press [On/Off switch] twice to start PT-6.

INSTALLING THE BATTERY

Pull the latch to the left with thumbnail to release the hinged battery compartment cover. Carefully unplug the battery without straining the cables. Replace with a fresh battery. Replace cover. Use a standard 9 Volt battery.

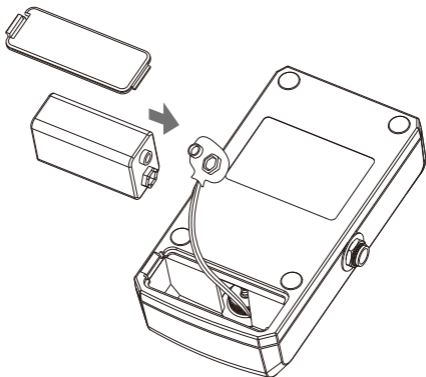

NOTE: Pay attention to polarity when replacing batteries.

Remove the batteries if the product will not be used for a long period.

SPECIFICATIONS

- Tuning mode: Chromatic
- Tuning range: $A_0(27.5)\sim C_8(4186\text{Hz})$
- A4 range: 435~445Hz
- Flat tuning: $\flat \ \flat\flat \ \flat\flat\flat \ \flat\flat\flat\flat$
- Tuning precision: ± 1 cent
- Detection method: Audio Signal Input
- Display mode: LED
- Tuning method: Auto
- Power: 9V battery or DC 9V adaptor $\oplus \ominus$
- Dimensions: 122(L) x72(W) x47(H)mm
- Weight: 235g

PRECAUTIONS

- Environment:
 1. Do NOT use the pedal in high temperature, high humidity, or subzero environments.
 2. Do NOT use the pedal in the direct sunlight.
- Please do NOT disassemble the pedal by yourself.
- Please keep this manual for future reference.

ACCESSORIES

- User manual
- 9V battery

THE FCC REGULATION WARNING (for U.S.A.)

This equipment has been tested and found to comply with the limits for a Class B digital device, pursuant to Part 15 of the FCC Rules. These limits are designed to provide reasonable protection against harmful interference in a residential installation. This equipment generates, uses, and can radiate radio frequency energy and, if not installed and used in accordance with the instructions, may cause harmful interference to radio communications. However, there is no guarantee that interference will not occur in a particular installation. If this equipment does cause harmful interference to radio or television reception, which can be determined by turning the equipment off and on, the user is encouraged to try to correct the interference by one or more of the following measures:

- Reorient or relocate the receiving antenna.
- Increase the separation between the equipment and receiver.
- Connect the equipment into an outlet on a circuit different from that to which the receiver is connected.
- Consult the dealer or an experienced radio/TV technician for help.

CE mark for European Harmonized Standards

CE Mark which is attached to our company's products of Battery mains the product is in fully conformity with the harmonized standard(s) EN 61000-6-3:2007+A1:2011 & EN 61000-6-1:2007 Under the Council Directive 2004/108/EC on Electromagnetic Compatibility.

©2012 Cherub Technology-All rights reserved.
No part of this publication may be reproduced
in any form without prior written permission
of Cherub Technology.

www.nuxefx.com



Made in China