

User Manual



FOOT CONTROLLER FCV100

Ultra-Flexible Dual-Mode Foot Pedal for
Volume and Modulation Control

Table of Contents

Thank You	2
Important Safety Instructions	3
Legal Disclaimer	4
Limited Warranty	4
1. Safety Precautions	5
2. Control Elements.....	5
3. Battery Installation & Replacement.....	6
4. Connections	7
5. Specifications	8

Thank you

Thank you for the confidence you have placed in us by purchasing the FOOT CONTROLLER FCV100.

The FCV100 is a valuable and versatile tool in your equipment. Its multiple functions give you the freedom to control even more parameters by simply using your foot on the pedal. You are able to control the volume or modulation of one stereo or two individual musical instruments. With your FCV100 you have a reliable tool that excels in both live and studio performances.

EN Important Safety Instructions



Terminals marked with this symbol carry electrical current of sufficient magnitude to constitute risk of electric shock. Use only high-quality professional speaker cables with ¼" TS or twist-locking plugs pre-installed. All other installation or modification should be performed only by qualified personnel.



This symbol, wherever it appears, alerts you to the presence of uninsulated dangerous voltage inside the enclosure - voltage that may be sufficient to constitute a risk of shock.



This symbol, wherever it appears, alerts you to important operating and maintenance instructions in the accompanying literature. Please read the manual.



Caution

To reduce the risk of electric shock, do not remove the top cover (or the rear section).

No user serviceable parts inside. Refer servicing to qualified personnel.



Caution

To reduce the risk of fire or electric shock, do not expose this appliance to rain and moisture.

The apparatus shall not be exposed to dripping or splashing liquids and no objects filled with liquids, such as vases, shall be placed on the apparatus.



Caution

These service instructions are for use by qualified service personnel only. To reduce the risk of electric shock do not perform any servicing other than that contained in the operation instructions. Repairs have to be performed by qualified service personnel.

1. Read these instructions.
2. Keep these instructions.
3. Heed all warnings.
4. Follow all instructions.
5. Do not use this apparatus near water.

6. Clean only with dry cloth.
7. Do not block any ventilation openings. Install in accordance with the manufacturer's instructions.
8. Do not install near any heat sources such as radiators, heat registers, stoves, or other apparatus (including amplifiers) that produce heat.
9. Do not defeat the safety purpose of the polarized or grounding-type plug. A polarized plug has two blades with one wider than the other. A grounding-type plug has two blades and a third grounding prong. The wide blade or the third prong are provided for your safety. If the provided plug does not fit into your outlet, consult an electrician for replacement of the obsolete outlet.
10. Protect the power cord from being walked on or pinched particularly at plugs, convenience receptacles, and the point where they exit from the apparatus.
11. Use only attachments/accessories specified by the manufacturer.



12. Use only with the cart, stand, tripod, bracket, or table specified by the manufacturer, or sold with the apparatus. When a cart is used, use caution when

moving the cart/apparatus combination to avoid injury from tip-over.

13. Unplug this apparatus during lightning storms or when unused for long periods of time.

14. Refer all servicing to qualified service personnel. Servicing is required when the apparatus has been damaged in any way, such as power supply cord or plug is damaged, liquid has been spilled or objects have fallen into the apparatus, the apparatus has been exposed to rain or moisture, does not operate normally, or has been dropped.

15. The apparatus shall be connected to a MAINS socket outlet with a protective earthing connection.

16. Where the MAINS plug or an appliance coupler is used as the disconnect device, the disconnect device shall remain readily operable.



17. Correct disposal of this product: This symbol indicates that this product must not be disposed of with household waste, according to the WEEE Directive (2012/19/EU)

and your national law. This product should be taken to a collection center licensed for the recycling of waste electrical and electronic equipment (EEE). The mishandling of this type of waste could have a possible negative impact on the environment and human health due to potentially hazardous substances that are generally associated with EEE. At the same time, your cooperation in the correct disposal of this product will contribute to the efficient use of natural resources. For more information about where you can take your waste equipment for recycling, please contact your local city office, or your household waste collection service.

LEGAL DISCLAIMER

MUSIC Group accepts no liability for any loss which may be suffered by any person who relies either wholly or in part upon any description, photograph, or statement contained herein. Technical specifications, appearances and other information are subject to change without notice. All trademarks are the property of their respective owners. MIDAS, KLARK TEKNIK, TURBOSOUND, BEHRINGER, BUGERA and DDA are trademarks or registered trademarks of MUSIC Group IP Ltd. © MUSIC Group IP Ltd. 2015 All rights reserved.

LIMITED WARRANTY

For the applicable warranty terms and conditions and additional information regarding MUSIC Group's Limited Warranty, please see complete details online at

1. Safety Precautions

Detailed safety precautions:

Please read all safety precautions and operating instructions before you attempt to operate the unit. Follow all safety precautions and keep operation instructions for future reference.

Damage:

Take care not to drop your FCV100 as this can lead to severe damage. BEHRINGER assumes no liability for any damage caused by the user.

Maintenance and care:

If the FCV100 is not used for more than three months, please remove the battery to avoid damage caused by battery leakage. The FCV100 will automatically turn on as soon as plugs are inserted into the inputs. To save battery power, remember to unplug the jacks when the unit is not being used.

For mains connection, use a 12 V DC power adapter with a current rating higher than 10 mA. A wrong power adapter may damage the unit.

Clean your FCV100 with a dry cloth. Avoid using volatile solvents as they may damage the surface.

2. Control Elements

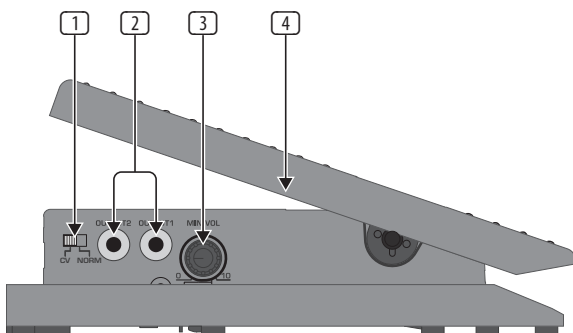

Fig. 2.1: FCV100 controls (part 1)

- 1 By switching into "NORM" mode, the FCV100 is capable of controlling the volume of two individual musical instruments. Signals from INPUT 1/2 are led to OUTPUT 1/2. In "CV" mode the FCV100 can control modulation and volume levels of other musical instruments by connecting OUTPUT 2 to the volume or modulation input of the instrument. In "CV" mode, when OUTPUT 2 is in use, INPUT/OUTPUT 1 can still be used for controlling the volume of another instrument, similar to "NORM" mode. All connections are made with standard ¼" TRS plugs.
- 2 In "NORM" mode, these jacks are used to feed separate instrument inputs with the FCV100's input signal. If you only use OUTPUT 2 in "CV" mode, the FCV100 functions as a CV controller.
- 3 Turning the MIN VOL control fully clockwise will increase the volume at the minimum setting. This allows you to set the volume range.

- 4 By using the pedal in the NORM mode, you control the volume level in both channels. In CV mode, the pedal controls OUTPUT 2 for a remote control of parameters such as sound or effects.

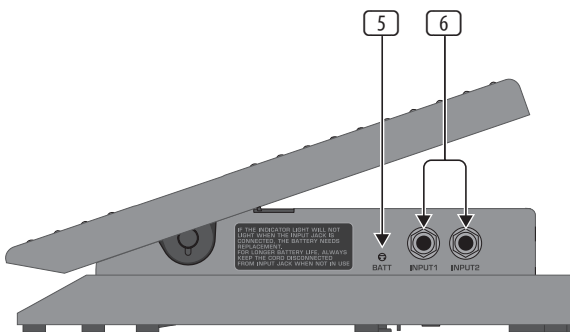

Fig. 2.2: FCV100 controls (part 2)

- 5 When the battery LED indicator dims or does not light up, you need to replace the battery. For instructions on how to replace the battery, please refer to chapter 3 “BATTERY INSTALLATION & REPLACEMENT”.
- 6 Connect your instruments via the INPUTS 1/2 using the “NORM” mode. In “CV” mode, INPUT 2 of your FVC100 can not be used since the control signal comes exclusively from OUTPUT 2. As stated before, you may use INPUT 1/OUTPUT 1 also in “CV” mode to control the volume level of instruments.

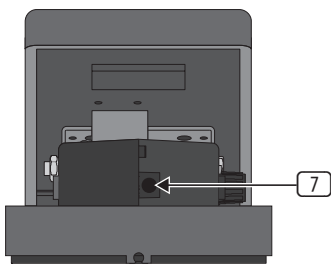

Fig. 2.3: FCV100 controls (part 3)

- 7 The FCV100 can be operated via an 12 V DC power adapter or with a 9 V battery (Type 6LR91). If you use a battery and the power adapter at the same time, the FCV100 draws no power from the battery.

3. Battery Installation & Replacement

To access the battery compartment, please follow the instructions:

1. Loosen the latch screw on the underside of the FCV100 and remove the base.
2. Remove the old battery and replace it with a new one.
3. Reattach the base.

◆ Remember to unplug the jacks when the unit is not being used so as to conserve battery life.

4. Connections

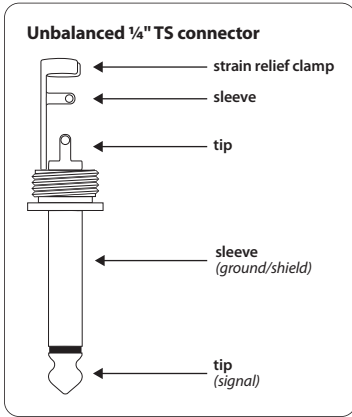

Fig. 4.1: 1/4" TS connector

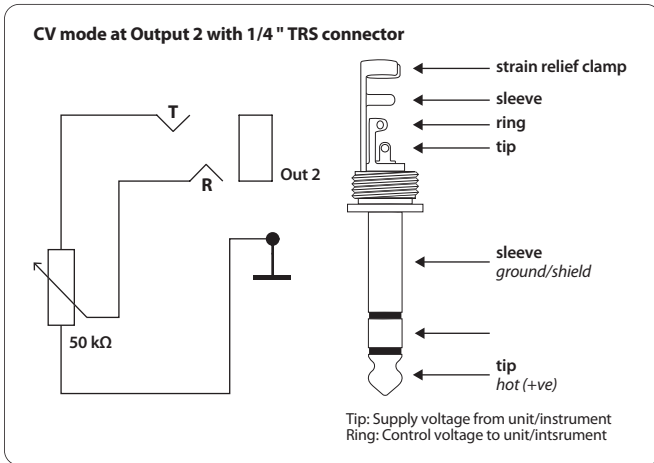

Fig. 4.2: 1/4" TRS connector (in CV mode at OUTPUT 2 only)

EN 5. Specifications

Input/output	<p>¼" TS connectors, unbalanced</p> <p>Tip: Supply voltage from unit/instrument to be controlled (Impedance: 50 kΩ)</p> <p>Ring: Slider pick-up control voltage dependent on pedal position (Impedance: 0...50 kΩ)</p>
Maximum input level	2 V (RMS)
Input impedance	300 kΩ
Output impedance	560 Ω
Attenuation range	0 - 70 dB
Total harmonic distortion	0.04% (1 kHz @ 1 V (RMS) output)
Signal-to-noise ratio	94 dB
Power supply	12 V / >10 mA DC power adapter
Battery power	9 V battery type 6LR91
Power consumption	7 mA
Dimensions	113 x 248 x 117 mm (4.4 x 9.8 x 4.6")
Weight	1.2 kg (2.5 lbs)

BEHRINGER is constantly striving to maintain the highest professional standards. As a result of these efforts, modifications may be made to existing products from time to time without prior notice. Specifications and appearance may therefore differ from those listed or shown.



We Hear You

behringer.com

