

# ANTHEM™

TRU•MIC TECHNOLOGY

INSTALLATION MANUAL

*L.R. Bayne*

## 1. PACKAGE CONTENTS

One Anthem preamp/controls  
One Tru • Mic  
One Element pickup  
One pre-wired strapjack harness  
One battery wire  
One battery bag  
Six self-stick wire clips  
One extra adhesive set for Anthem preamp  
One extra adhesive set for Tru • Mic

## 2. OVERVIEW AND CAUTIONS

The Anthem system features our patent pending Tru • Mic technology. The mic is designed to capture the majority of your guitar's true voice in a way that only a microphone is capable of - plus it is amazingly feedback resistant. Our Element under saddle pickup carries only the lowest frequencies for punch and authority. The soundhole mounted controller has volume, mix and phase controls plus a battery check feature so you can always be sure of your battery life at any gig.

This system must be installed by a professional dealer/installer. We do not provide installation advice or support for home or hobbyist installations. Installers: please read the instructions carefully before proceeding. We will not be responsible for any damage to the guitar, pickup system or personal injury resulting from installation.

The Anthem's preamp was designed to fit a 4 inch soundhole and standard X braced guitars. Before you begin a permanent installation of the complete system, check to see if the soundhole and bracing will accommodate the preamp (see figure 1).

**Note:** If the Anthem's control unit does not fit in your instrument, we offer the Anthem-SL. This scaled-down version of the Anthem with endpin preamp is preset for optimum performance and includes a soundhole mounted remote with volume and mic gain trim controls.

## 3. STRAPJACK INSTALLATION

### Drilling the strapjack hole

For proper installation, this jack requires a clean 1/2" hole in the tail block of the instrument. If the guitar lacks this hole, start by placing a piece of masking tape on the outside of the instrument over the drilling area (to avoid chipping the finish), drill a small pilot hole in the tail block and then follow with a step drill bit.

### Installing the strapjack

Remove the strap ring, retaining nut and one washer from the smaller threaded section of the jack. There should still be one star locking washer, one flat washer and a nut remaining on the larger threaded section of the jack. Bring the jack down through the soundhole into the body and insert it into the pre-drilled hole in the tail block. Using the internal nut (be sure to include the flat and star washers), set the proper depth that will allow the entire smaller threaded section to protrude from the instrument (see figure 2). With the jack in place, lay the remaining washer over the threads and attach the external retaining nut until it's tight. Finish by attaching the strap ring (it should cover the retaining nut and washer). Asserting too much pressure may crack the finish.

Note: to prevent rattles that the Tru • Mic will hear, secure the barrel cover against the pinch nut. If the tail block is too thin and the barrel cover will not reach the pinch nut, tighten the barrel cover until it fits snug. Do not over-tighten.

## 4. ELEMENT PICKUP INSTALLATION

### For optimum performance

The bridge slot must have a clean, flat surface free of debris and excess over-spray from lacquer, (sometimes left from guitar manufacturers). String balance problems are often the result of an uneven interface between the bottom of the saddle and the saddle slot floor. Both surfaces must be completely flat to give you the best chance at a successful installation.

The depth of the saddle slot is an important factor. A tip to help determine if your slot depth is adequate is the 50/50 rule which basically says: The amount of saddle visible above the bridge surface (with pickup installed) should be equal to or less than the amount of saddle in the slot beneath the bridge surface. An installation in which you have a tall saddle in a very shallow slot could be the cause of problems ranging from string to string imbalance, excess feedback, and poor tone quality.

fig. 1

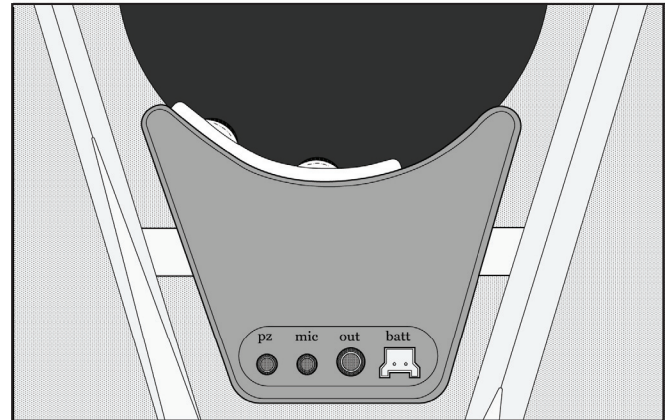

This is an internal view of the preamp mounted to the upper side of the soundhole. Notice the fit between the braces.

fig. 2

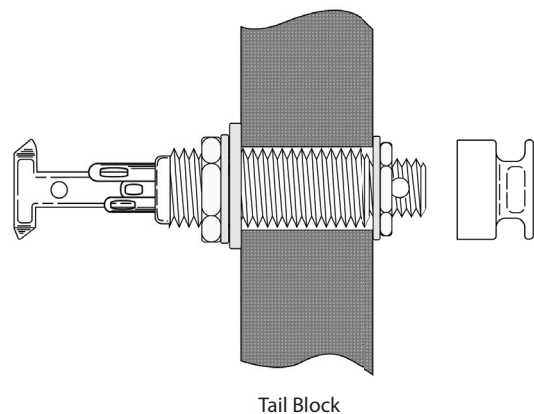

Tail Block

## Drilling the hole

Use a drill bit with a diameter that is large enough for the pickup to fit through but no larger than the width of the slot, usually between 3/32" and 1/8". It is recommended the hole be drilled on the bass side of the slot; this will allow for clean routing of wires to the preamp inside the guitar. Just before you begin, inspect the inside of the guitar and note the position of the braces in relation to the saddle slot. Drill the hole in the extreme end of the slot at a slight angle being careful to avoid all braces as the drill bit penetrates the top (see figure 3). Using an exacto blade or a small jeweler's screwdriver, round off the sharp edge of the hole where the pickup bends to protect the pickup from being kinked or pinched. Clean all loose debris from the slot.

## Preparing the saddle

You will need to compensate for the thickness of the pickup in the overall height of the saddle by removing approximately .032" of saddle material. We recommend you do this from the bottom of the saddle. This will allow you to make sure the bottom of the saddle is absolutely flat while maintaining intonation/compensation on the topside.

Remove the majority of the material on a belt sander first. Finish it off by hand sanding against a perfectly flat surface with semi fine sandpaper; 180 to 220 grit paper is good. Finally, check the flatness of the saddle by shining a light behind it while it rests on the flat surface.

## Saddle fit

Another very important consideration is the fit of the saddle. This is the single most important factor in this installation! The saddle should fit loosely enough that you could remove it using only your fingertips, but not so loose that it will fall out when turned over.

A saddle that fits too tight won't be able to seat firmly on the pickup and thus will not function properly. The most common results of this are very poor string balance, low output, low frequency microphonic response, boominess and bad tonality.

A loose fitting saddle will result in saddle tilt or lean while under pressure. This will cause poor contact in a different way. When the strings are at full tension, the saddle will pull forward and distribute pressure solely on the front edge of the pickup. This will result in poor tonality and possible string balance problems. One way to compensate for a loose fitting saddle is to sand an intentional angle on the bottom surface of the saddle so that it will make even contact under full string tension (see figure 4). This is not an easy task to accomplish accurately, so we recommend that only the most experienced installers attempt this. Another option is to create a new saddle.

## Installing the pickup

Once you have the saddle prepared, feed the pickup into the slot from inside of the guitar. Tip: insert a tooth pick, small Allen wrench or similar object through the hole from outside the guitar to aid you in locating the hole inside the guitar. As you lay the pickup in the slot, make sure the black dot at the end of the pickup is facing up. This will insure proper pickup phase orientation. Place the saddle in the slot over the pickup and temporarily secure it with a piece of tape. Secure the wire with a wire clip as close to the exit hole as practical (see figure 8). Failure to secure the pickup may produce excess boominess and feedback.

## Special considerations

**Saddle material:** Undersaddle pickups respond differently to various saddle materials and sometimes the differences can be startling. Variations in the saddle material effect everything from output to string balance and tone. It's sometimes a good idea to experiment with a couple different types of saddles to get the best results.

**Short saddle:** The last 1/8" of the Element is not active. If you do not have a minimum of 3/16" of saddle beyond the high-E string, you may experience low output from that string. To remedy this, you can drill a small horizontal hole into the wall of the bridge at the end of the slot approximately 1/4" in length to extend the active area of the pickup further under the saddle (see figure 5).

To drill this hole without disturbing the floor of the slot, place a small jeweler's screwdriver under the tip of the bit as you drill. We advise that you drill the pickup exit hole at the opposite end of the slot through the wall of the bridge as well (see figures 6 & 7).

fig. 3

This view depicts the bridge at an angle that is level with the guitar top and perpendicular to the saddle slot. Note the rounded edge where the hole has been drilled.

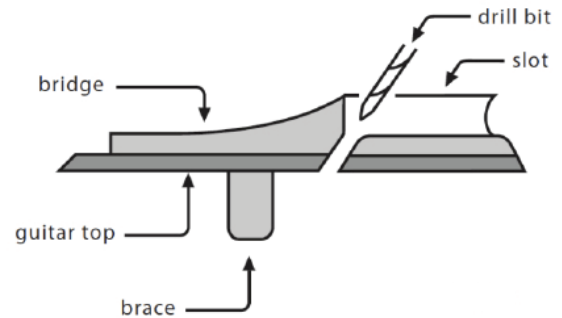
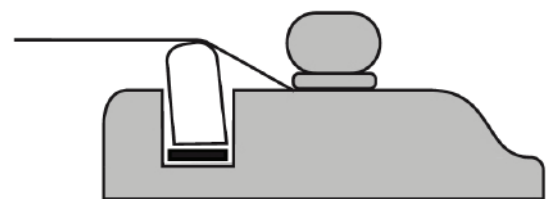

fig. 4



proper saddle-pickup contact  
(saddle lean exaggerated)

fig. 5

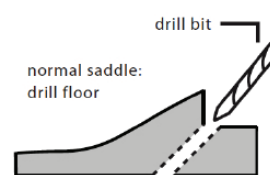
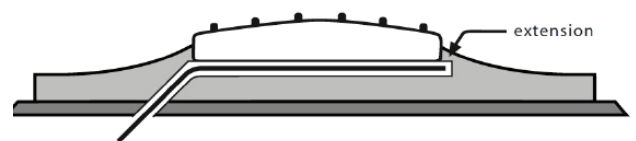

fig. 6

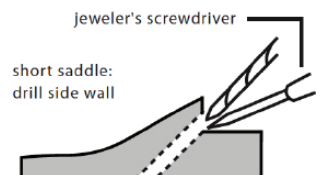

fig. 7

## 5. TRU • MIC INSTALLATION

The Tru • Mic is designed to attach to the center of the guitar's bridge plate with the included peel-and-stick VHB adhesive. CAUTION: Install the mic with only the adhesive set provided. Do not use super glue as this can damage the mic. Best results should be consistently had by attaching the mic as shown in (figure 8). Unlike conventional soundboard transducers, the Tru • Mic's positioning is not highly critical, so repositioning the mic to find its optimum location will not be necessary. Reach inside the hole and clean around under the bridge to be sure the bridge plate is free from oil, dust and other debris. Remove the adhesive backing from the bottom surface of the Tru • Mic and attach to the bridge plate. Be sure to attach the mic so that the wire is facing the bass side of the Bridge. This direction will allow for a clean and simple wire routing to the preamp. Press up firmly along the top surface of the Tru • Mic, especially on the ends to secure it. It's usually a good idea to press down on the bridge from the outside of the guitar as you press up on the Tru • Mic from the inside to equalize pressure and avoid cracking the top. Gently wiggle the Tru • Mic front to back as you press. Lastly, secure the wire with the same wire clip as the Element pickup (see figure 8).

If you ever need to remove the Tru • Mic from the bridgeplate, place as many fingers as you can fit behind its side and pull towards the neck with a little downward pressure. Before replacing the mic, make sure the adhesive pads are completely removed from the bridgeplate.

## 6. BATTERY BAG PLACEMENT

Stick the double-sided adhesive to an easily accessible spot on the back, side or neck block. Insert the battery and battery snap into the bag. The battery can then be changed by opening the flap on the bag and pulling out the battery.

## 7. INSTALLING THE PREAMP

### Connecting to the preamp

Note: It is much easier to make all connections outside of the soundhole before permanently installing the Preamp.

- Connect the Element pickup to the jack labeled pz.
- Connect the Tru • Mic to the jack labeled mic.
- Connect the strapjack harness to the jack labeled out.
- Connect battery wire to the jack labeled batt.

### Preamp placement

The preamp mounts inside the guitar on the top/bass side of the soundhole with the Anthem's control panel riding along the soundhole's edge (see figure 9). Be sure to clean the area of oil, dust and debris just prior to installing the preamp. Once again, temporarily hold the preamp in place where you intend to install it to make sure that the bracing does not interfere. Now peel of the backing from the adhesive and carefully set the preamp in place. Make sure everything lines up before you apply much pressure. When placement is satisfactory, apply firm pressure to the back of the preamp to fully secure the adhesive while applying counter pressure from outside the guitar. (See figure 1 for internal view)

Secure all wires with the wire clips provided and re-string the guitar.

## 8. TESTING & ADJUSTMENTS

Plug into your acoustic amp or PA and confirm that the EQ controls are at their default positions.

### A. MIX CONTROL (Mixes between mic and pickup)

When the mix control is rolled towards the neck, the Tru • Mic is carrying the majority of the guitar's voice with the Element pickup supporting only the lowest frequencies.

When rolled towards the bridge, you will hear the full-range Element pickup only.

When set at full-range pickup, pay careful attention to string balance. If you notice any inconsistencies in output, refer back to 4. ELEMENT INSTALLATION.

### B. PHASE INVERSION

Press this button to invert the phase. Usually one phase will sound best and/or provide the best feedback resistance.

We recommend trying both phases each time you set up.

### C. VOLUME CONTROL

Roll this wheel towards the neck to increase the volume or towards the bridge to decrease the volume.

fig. 8

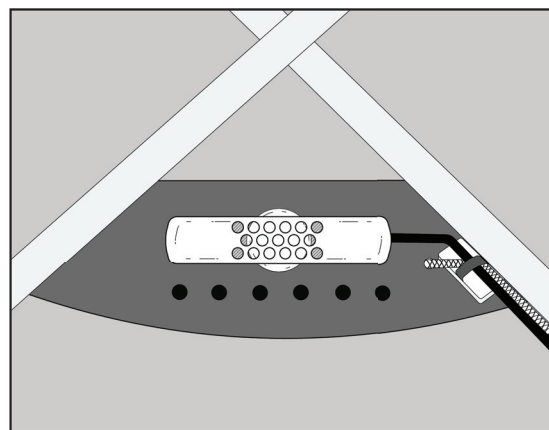

*This is an internal view with the Tru • Mic mounted on the center of the bridge plate. The Tru • Mic and Element wires are secured with one wire clip on the bass-side of the bridge plate near the exit hole.*

fig. 9

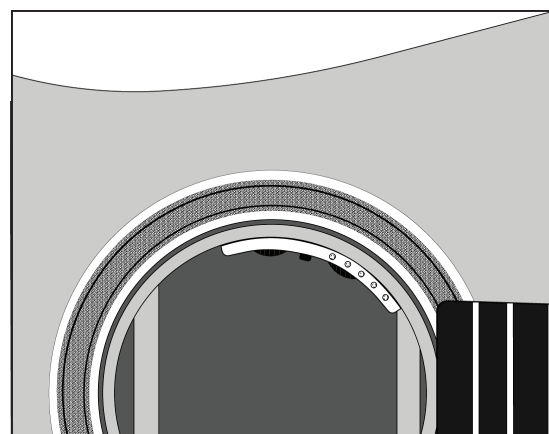

*This view shows the proper placement of the Anthems control cover.*

fig. 10

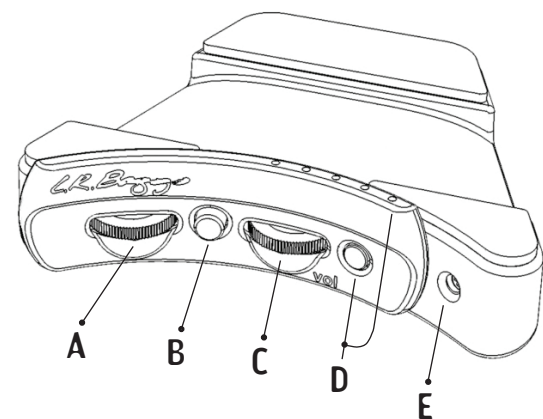

#### D. BATTERY CHECK

Press this button to check battery life.

A full battery will light up all 5 LED's and should give you approximately 170 hours of playing time. When only two lights are lit you have about 8 hours of normal playing time left. If only one light is lit, replace the battery.

The battery is typically mounted on the neck block or the upper bout.

To maximize battery life, make sure to unplug your instrument cable when not using the Anthem. The battery check will work even when there is no cable plugged in.

#### E. MIC GAIN CONTROL (Adjusts the level of the Tru • Mic relative to the level of the Element)

**IMPORTANT:** Setting this control correctly is vital to the sound of the Anthem system.

First, you must roll the mix control completely toward the neck. Play through a P.A. or acoustic amplifier while you are making adjustments. A small flat-head jeweler's screwdriver will be needed.

Your amplified tone should be well balanced and true to the acoustic sound and feel of the guitar. If it lacks clarity and top-end, increase the mic's level by turning the control clockwise. Back it off slightly if you experience excessive handling noise and/or brightness.

The logo for L.R. Baggs, featuring the name in a stylized, handwritten script font. The letters are dark grey or black, and the 'g' has a distinctive loop.