

# Operation Manual

---



Munro Sonic®

EGG 150  
MONITORING SYSTEM



## Contents

### EGG 150 MONITORING SYSTEM

Dual Input Amplifier (Control Panel) Front	Pg 4
Dual Input Amplifier (Control Panel) Back	Pg 5

### SETTING UP YOUR SYSTEM

Setup and Operation	Pg 6
Positioning	Pg 6
Equalisation	Pg 7
Midrange Balance	Pg 7
Control Unit	Pg 7
Protection	Pg 7
Running In	Pg 8

<b>TECHNICAL INFORMATION</b>	Pg 9
------------------------------	------

<b>SAFETY NOTICE</b>	Pg 10
----------------------	-------

Thank you for purchasing your Munro Sonic EGG 150 Monitoring System, designed by Mr Andy Munro, one of the world's leading acousticians and monitor experts, and manufactured in the UK. Your system has been constructed using the finest quality components and extensively tested to ensure years of trouble free operation.

If something goes wrong, you won't get left without your speaker system.

If you register your product at [www.munrosonic.com/product-registration](http://www.munrosonic.com/product-registration), your standard 1 year free replacement warranty (excluding drivers) will be extended free of charge to 2 years. This is unique in the world of studio monitors, and means that if there is a technical fault caused by a manufacturing defect within the first 2 years from date of purchase, then we'll replace the entire system free of charge, immediately. We only ask for you to cover the cost of returning your system to us – the rest, we take care of for you. No other company goes this far. We're able to do this because this system is so well built.

## DUAL INPUT AMPLIFIER (CONTROL UNIT)

### FRONT PANEL

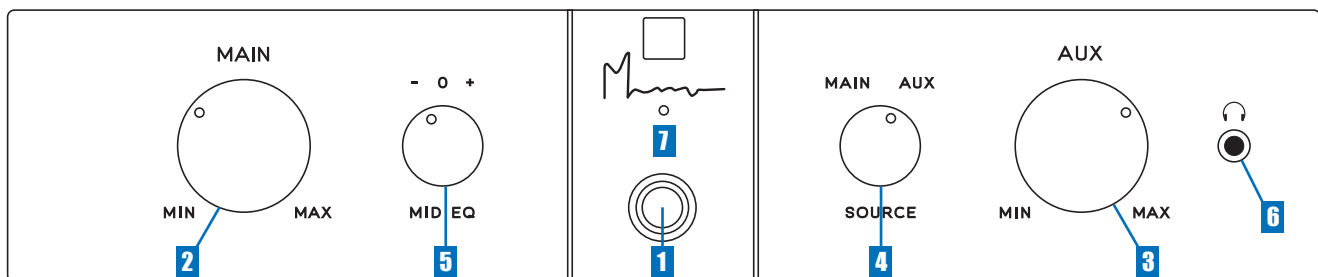

#### 1 MAIN SWITCH

An illuminated switch for the entire system allows safe power up and shut down without having to access the rear of each individual Egg monitor.

#### 2 MAIN VOLUME

A precision potentiometer allows continuous listening level control of the main input channel without the need to access the individual speakers.

#### 3 AUX VOLUME

Independent control of the Aux Input volume provides a useful record/playback comparator (or any other alternate source input).

#### 4 SOURCE

Source select allows the comparison of two independent inputs. Input sensitivity of the main input can be selected on the rear panel.

#### 5 MID EQ

This three way switch allows instant comparison of the 'flat' reference response with a slightly harder mid range or a softer 'HiFi' setting. See page 7 for more information.

#### 6 HEADPHONE SOCKET

An independent headphone amplifier is used to listen to whichever input is selected. Inserting the headphone jack mutes the power amplifiers.

#### 7 HEADROOM INDICATOR

An LED indicator designed to help protect your Egg system from overload. See Page 7 for more information.

## IMPORTANT NOTICE

**ENSURE THE MAINS VOLTAGE SELECTOR SWITCH IS IN THE CORRECT POSITION BEFORE CONNECTING TO THE MAINS POWER SUPPLY.**

**YOUR EGG 150 MONITORING SYSTEM CONTAINS:**

- 1 x Dual Input Amplifier / Control Unit**
- 1 x Left Speaker**
- 1 x Right Speaker**
- 2 x 3m Speakon Speaker Cable**
- 2 x Amp Rack Ear**

## DUAL INPUT AMPLIFIER (CONTROL UNIT)

### REAR PANEL

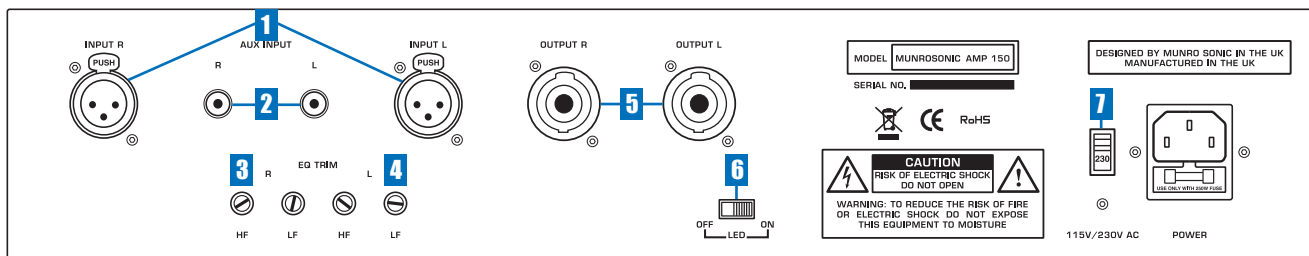

### 1 MAIN INPUTS

Industry standard balanced XLR connectors. Pin 2 is +ve.

### 2 AUX INPUTS

Unbalanced RCA Phono connectors for consumer level (-10dBu) equipment.

### 3 HF TRIM

The HF trim pots are designed to give absolute precision alignment of each channel and adjustment for personal taste. When set to maximum (fully clockwise) the tweeters are at maximum sensitivity. The graduation is approximately -1dB at 10kHz for each 45 degrees of anticlockwise rotation.

### 4 LF TRIM

The LF trim allows adjustment for speaker location and room acoustic effects. The reference (flat) setting is fully clockwise and up to 10dB of roll-off at 63Hz is available on each channel. See diagrams on page 8 for frequency range.

### 5 OUTPUTS

The speaker connectors are industry standard 4 way Speakons with unique (foolproof) polarity alignment. The cables supplied with each Egg system are very high quality, impedance matched multicore and under no circumstance should these be changed or extended without advice from Munro Sonic. See diagram for pin connections.

### 6 LED

The focal point aiming LEDs on the speakers can be switched off once the system is aligned and no further adjustment is likely. See page 6 for more information. You can leave the LEDs on if preferred.

### 7 VOLTAGE SELECTOR

The voltage must be set to the appropriate value and the fuse is designed to protect the Egg system from excessive current flow. Fuses should only ever be replaced with one of the correct value.

## Setup and Operation

The Egg 150 is designed specifically for near-field, free standing operation. This means that adjacent equipment and surfaces will have some effect on the performance of the system and this should be taken into account when planning and installing the speakers. The openness of the sound balance will be at its best in a room that is acoustically treated in such a way as to be as neutral as is reasonably possible. Too much foam panelling on the walls and no bass absorption will create an uneven spectrum and some effort should be made to avoid this. A free guide to acoustics will be available from Munro Sonic upon request.

## Positioning

The ideal listening position for stereo is at between 1.0 and 1.5 metres from the speakers with the speakers the same distance apart from each other. It is better to place them closer rather than further apart if possible. The LED aiming device is intended to assist both the vertical and horizontal alignment. It is particularly important to place the speakers at the correct height and angle to see both LEDs at their brightest. This will ensure that the time alignment of the drivers will be optimum. It is ok to use the integral stands to angle the speakers in order to achieve this alignment (Figures 1 and 2) although as a general rule a horizontal axis will work best. A downward angle can increase the reflected sound from consoles or tables and that can result in a degradation of the mid frequency imaging.

When everything is optimised the centre image will appear very solid and slightly forward of the main stereo balance. A mono mix should be absolutely solid with no impression of smearing to one side or the other.

It should be noted that there are many factors that can affect stereo balance so the Egg will often show up phase and polarity issues with the rest of the system. That is what monitors are for!

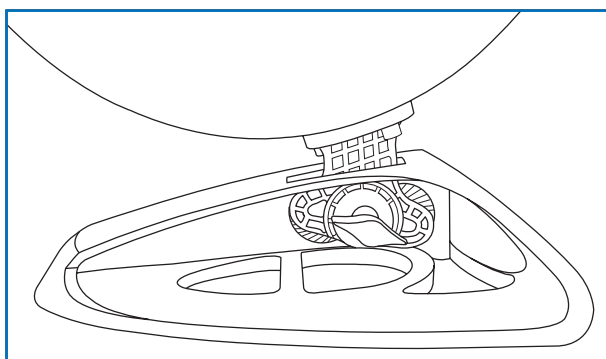
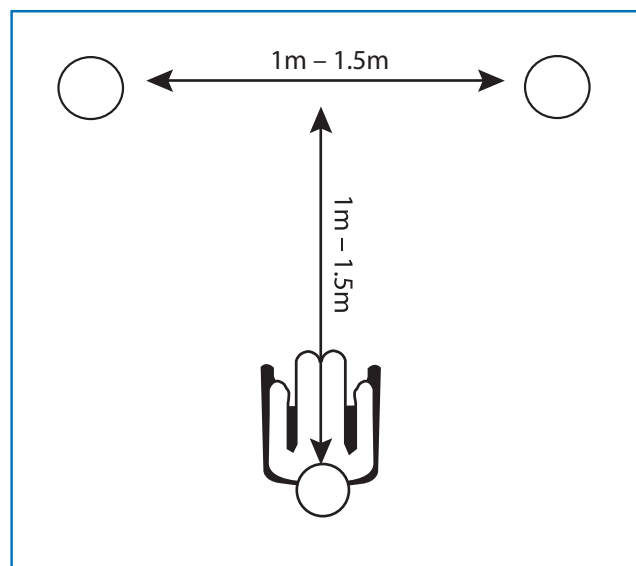

Figure 1

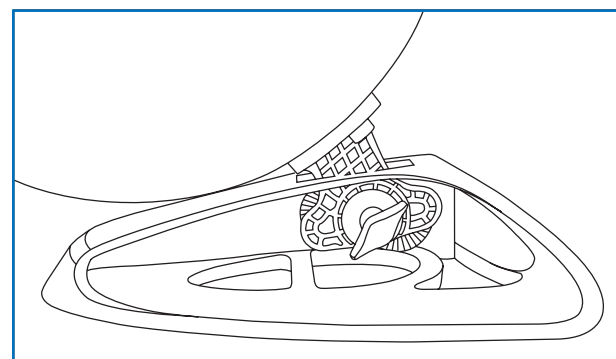

Figure 2

## Equalisation

The Egg 150 is naturally neutral in its frequency response. This is mainly a result of the acoustically optimal enclosure and the choice of small drivers with almost perfectly controlled directivity. However, not all rooms are neutral and also the positioning of the speakers will affect the response. Placing a speaker very near a wall will increase bass and a corner will have even more effect. This is because energy is reflected from any surface and that energy will be in phase with the direct sound at low frequencies. This might sound like a good thing but without some degree of acoustic treatment the results can be unpredictable as at some frequencies the reverse will occur and the reflections will tend to cancel the direct energy. The Egg has precision trim potentiometers to equalise the bass and high frequency response for a given location. The HF trim can be used to compensate for acoustic imbalances or (more likely) personal preference. We all hear high frequencies in slightly different ways and also some allowance may be required for the intended reproduction of the recording although almost all media have a 'flat' response these days. As a general guide a quarter turn (90°) will give 2dB of attenuation of the highest octave (see Fig 3) and that is the preferred setting for most studio monitoring applications.

## Midrange Balance

The Egg 150 has a unique feature and that is the midrange equalisation switch. Most studio engineers are familiar with the raised mid frequency response of some systems and this can be a useful 'magnifying glass' for vocals and other 'critical' aspects of the stereo mix. The Egg offers a subtle (+/- 1.5 dB) hard and soft response modifier. Of course we recommend the flat (neutral) position for most applications.

## Control Unit

The Egg is unique in that all the electronics are housed in a separate unit that can be placed within reach of the operator and within the listening area. This has several important advantages.

- All balancing and adjustment can be done without having to move back and forth behind the speakers.
- The power amplifiers do not compromise the acoustic integrity of the egg 'shell'.
- The unit acts as a source select and volume controller in its own right.
- The 3m speaker cables allow the unit to be placed in a rack or free standing.
- Power can be switched without having to clamber behind the speakers.

## Protection

The Egg 150 is well protected against electronic malfunction. An LED indicates when the system is approaching audio or thermal overload and this (when illuminated continuously or for more than a few seconds) should be regarded as a warning to either reduce monitoring level or allow the system some cooling time. The high currents used in professional loudspeakers are capable of generating very high voice coil temperatures and prolonged loud listening can cause driver failure.

Loud transients will pass through the system unhindered and the intermittent triggering of the overload LED is quite acceptable. Some manufacturers prevent this by limiting and signal processing but this can give a false impression of true dynamic range and can also impair sound quality.

The HF driver is fitted with a self resetting thermal fuse, therefore if the HF driver stops working, reduce the level and allow a few minutes for the fuse to reset. Then resume working but at a lower level to avoid a repeat.

## Running In

High quality drivers are used in the Egg 150 Monitoring Systems. When new, they will reach their optimum working performance after approximately 24 hours of operation and after that should still be allowed to warm up before serious mixing is carried out.

### System Adjustment Range

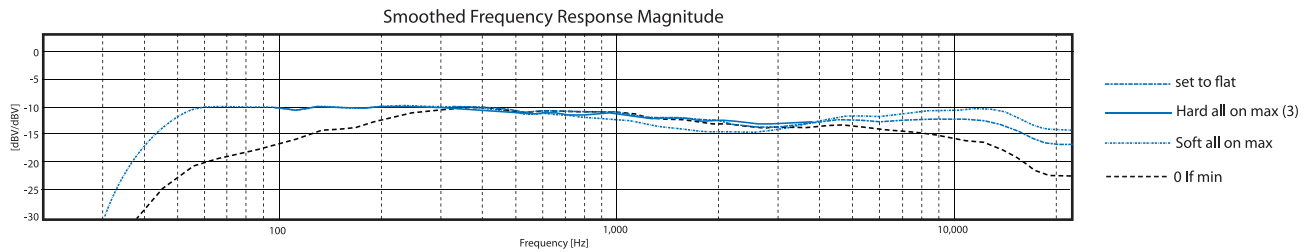

### In Room Equalisation (offset for clarity)

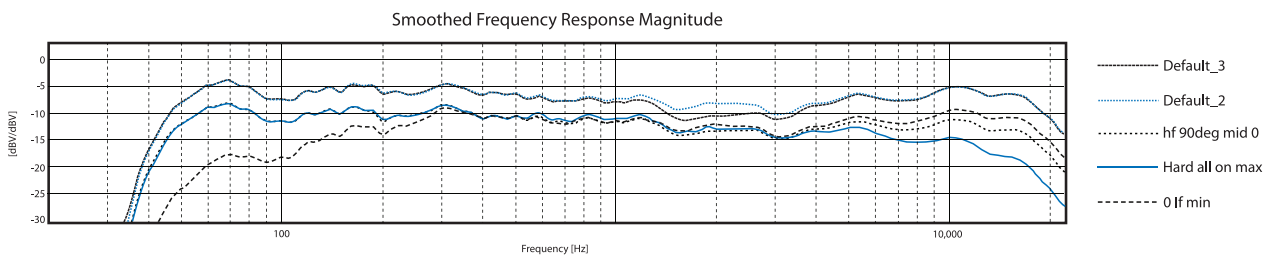

### Mid Frequency (Presence) Switch Settings

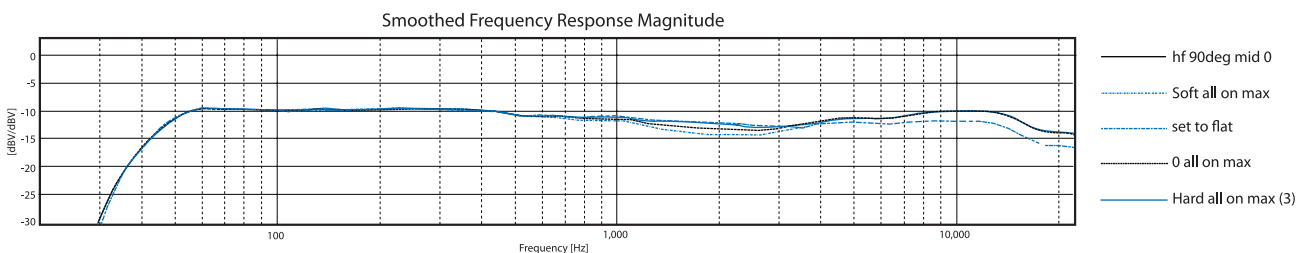

Reference Data	
Frequency Response	45Hz to 20KHz (-3dB points)
Low Frequency Room Calibration	+0/-10dB at 63 Hz continuously variable
High Frequency Calibration	+1/-5dB at 10kHz continuously variable
Mid Frequency Adjustment	+/- 1.5dB at 2kHz centre frequency



## Technical Specification

- System Stereo two way active control unit with four 50W RMS power amplifiers with dual linear power supplies
- High headroom capacitors and voltage rails
- Bass reflex speakers with 50Hz QB4 front port alignment
- Speaker effective internal volume: 14 Litres
- Two way asymmetrical electronic crossover with nominal 2kHz alignment
- 25mm HF unit sensitivity 95dB SPL for 1W at 1m
- 165mm LF sensitivity 89dB for 1W at 1m
- 118dB Peak SPL at 1kHz both channels driven
- Thermal tweeter protection with automatic cut out and reset
- Input sensitivity: Main +4/-10 dBu, Aux -10dBu
- Continuously variable dual monitor level controls with switchable inputs

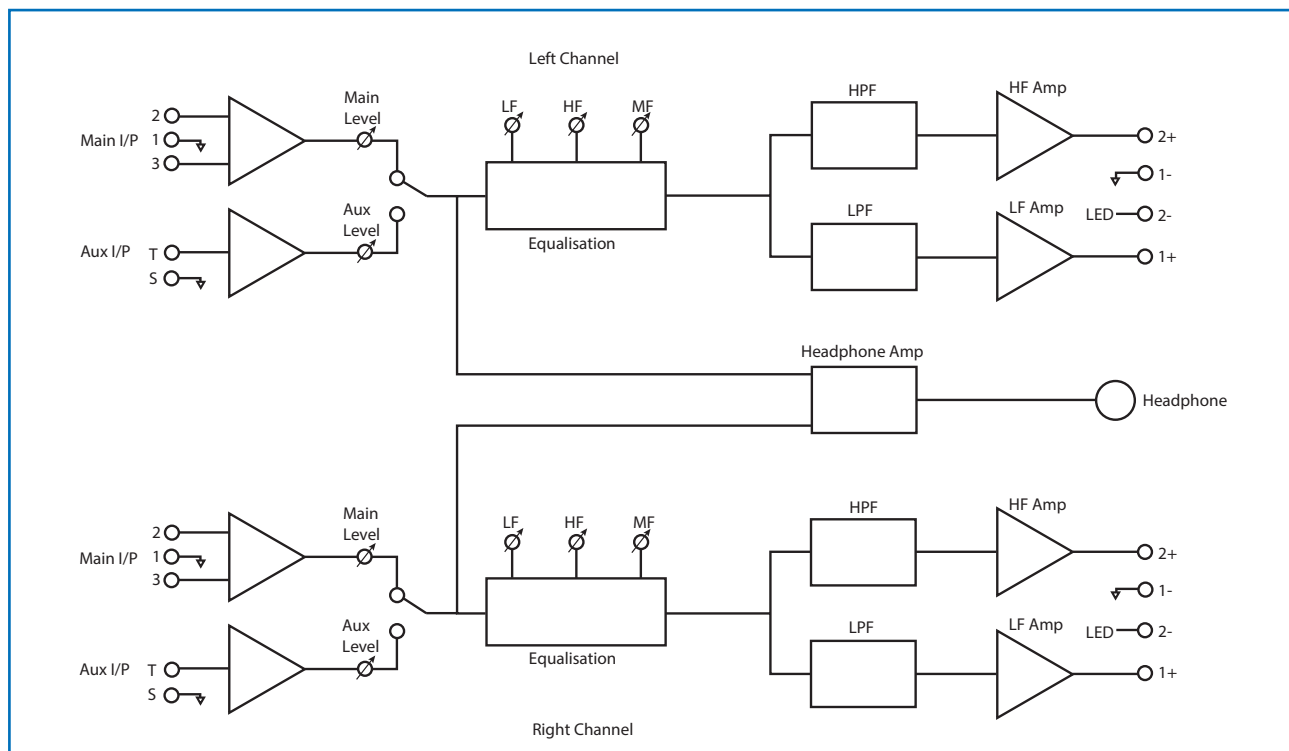

Egg 150 Monitoring System schematic

## BEFORE USING YOUR EGG 150 MONITORING SYSTEM PLEASE READ THESE NOTES CAREFULLY

### IMPORTANT SAFETY INFORMATION

This unit contains high voltages and hot components and must not be opened in any circumstances.

The Egg 150 is a complete stereo system and the control unit, speakers and interconnecting cables are unique. No substitutions of any sort should be used and no other speaker or amplifier can be used with the cables.

The IEC (or US Equivalent) three core mains cable must be used with appropriate regard for earthing and supply voltage. Do not use any other type of cable.

There are no user serviceable components inside the control unit and it is hazardous to open or operate the system with the unit open.

Internal fuses exist to protect the Egg components and in the event of system failure or inoperation please report the fault to Munro Sonic or their representative for further advice.

The control unit requires adequate ventilation and the top panel must not be covered or placed near a source of heat or moisture.

Do not disconnect the speaker cables when the system is switched on.

Set Volume controls to minimum before connecting/disconnecting inputs.

### WARNING

Always follow the basic precautions listed below to avoid the possibility of serious injury or even death from electrical shock, short circuiting, damages, fire or other hazards. These precautions include the following:

- ! The power supply (if included with this system) contains no user-serviceable parts. Do not attempt to disassemble or modify the internal components of the power supply in any way.
- ! Do not expose the system to rain, use it near water or in damp or wet conditions.
- ! If the power cord or plug becomes frayed, damaged, there is a sudden loss of sound during the use of the system or any unusual smells or smoke should appear to be caused by it, turn the power switch off immediately, disconnect the mains plug from the wall and have your system inspected by a qualified technician.
- ! Only use the voltage as specified as correct for the system supply.
- ! Always attach the three-pin attachment plug for the power supply to a properly grounded power source.
- ! Check the mains plug periodically and remove any dirt or dust that may have accumulated on it.
- ! Do not place the power cord near heat sources such as heaters or radiators and do not excessively bend or otherwise damage the power cord, place heavy objects on it or place it in a position where anyone could walk or trip over, or roll any thing over.
- ! When removing the power cable from either the power supply or the wall outlet, please do not jerk or pull on the power cord. Always remove the cord by holding the plug itself.
- ! Always connect the power supply to a direct outlet and not an extension cord. Doing so may result in an inadequate power supply for the unit to operate at specified levels.
- ! Always remove the plug from the outlet when the power supply is not in use for extended periods of time (longer than two weeks). Also remove the plug from the outlet during any electrical storm.
- ! Do not expose the system or power supply to any excessive dust or vibrations or extreme cold or heat. This includes but is not limited to: a car on a hot day, direct sunlight for long periods of time or near a heater or a radiator.
- ! Our power supplies are made for international use, so they all come with a voltage switch. This switch can be located on the back of the unit next to the on/off switch. You will have a selection between 115v or 230v. Please make absolutely sure that you have the correct voltage selected for your outlet as a mistake in selection could cause serious damage to the power supply and/or the system that is connected.

**MUNRO SONIC** cannot be held responsible for any damage caused by improper use or modifications of the system or power supply.





Munro Sonic®

**EGG 150**  
Monitoring System



MANUFACTURED IN THE UK

3 Hunting Gate, Hitchin, Hertfordshire, SG4 0TJ, United Kingdom

Tel. +44 (0)845 500 2 500

[www.MunroSonic.com](http://www.MunroSonic.com)