

apollo

HIGH-RESOLUTION INTERFACE
with Realtime UAD Processing



Apollo Thunderbolt Software Manual

Software Version 8

Manual Version 150428



UNIVERSAL AUDIO

Customer Service & Technical Support:

USA Toll-Free: +1-877-698-2834

International: +1-831-440-1176

www.uaudio.com

Table Of Contents

Tip: Click any section or page number to jump directly to that page.

Chapter 1: Introduction	6
Welcome To The Apollo Family	6
Apollo Software Features	7
Apollo Documentation Overview	9
Apollo Software Overview.....	11
Additional Resources	13
Chapter 2: Installation & Setup	14
Installation & Setup Overview	14
Software Installation	15
Chapter 3: Console Overview	16
What is Console?	16
Console Functions	17
Global Settings.....	17
When To Use Console.....	18
Interactions Between Console and Apollo	18
Accessing Console	19
Console Layout	20
Global Window Elements	22
Meter Bridge Overview.....	23
Current Bank Overview	24
View Column Overview.....	25
Monitor Column Overview	27
Info Bar Overview	28
UAD Plug-In Inserts Overview	31
Console Settings Overview	32
Insert Effects Overview.....	33
Cues Overview	34
Sends Overview	35
ALT Monitoring Overview	38
Console Sessions Overview.....	39
Flex Driver Overview	40

Popover Windows.....	41
Multiple Undo/Redo.....	41
Keyboard Focus & Control.....	42
Adjusting Console Controls.....	43
Controls Shortcuts.....	43
Keyboard Shortcuts.....	44
Apollo Model Differences.....	44
Chapter 4: Console Reference.....	45
Meter Bridge.....	45
View Column.....	48
View Options.....	51
Info Bar.....	57
Channel Input Controls.....	62
UAD Plug-In Inserts.....	65
Sends Popover.....	66
Flex Routing.....	67
Monitor Mix Controls.....	69
Aux Returns.....	75
Monitor Column.....	78
Cue Outputs Popover.....	82
Control Room Column.....	85
Console Sessions.....	87
Sessions Manager Popover.....	89
Window Title Bar.....	94
Application Menus.....	95
Chapter 5: UAD Plug-In Inserts.....	99
Inserts Display.....	99
Unison Insert.....	100
Insert Assign Popover.....	100
Insert State Indicators.....	101
Insert Hover Options.....	101
Insert Options Menu.....	102
Channel Insert Effects.....	103
Plug-In Editor Window.....	104

Channel Strips.....	107
Presets Manager	109
Presets Manager Popover.....	112
Save Preset Popover.....	114
Chapter 6: Console Settings.....	115
Console Settings Overview	115
Hardware Settings Panel	117
Core Audio Panel	125
Core Audio Panel Elements.....	126
Route Assign Popover.....	132
Display Panel	134
Plug-Ins Panel.....	136
MIDI Panel	138
Chapter 7: Console Recall Plug-In.....	140
Console Recall Overview	140
Console Recall Controls.....	141
How To Use Console Recall.....	142
Chapter 8: Unison	144
What is Unison?	144
Activating Unison	146
Unique Behavior of Unison Inserts	147
Controlling Unison Plug-Ins with Apollo	148
Unison Load/Save Behaviors	154
Unison Operation Notes.....	155
Chapter 9: Working With Apollo.....	157
Apollo Setups Overview	157
About UAD Powered Plug-Ins Processing.....	158
Using Apollo as an Audio Interface	160
Using Apollo with Console (without a DAW)	162
Using Apollo Without A Computer.....	163
Using Apollo with a DAW (without Console)	164
Using Apollo Concurrently with a DAW and Console.....	167
Virtual I/O	169

Chapter 10: Multi-Unit Cascading	171
Apollo Expanded Overview	171
Multi-Unit Wiring.....	172
Multi-Unit Operation	173
Console Session Management	177
Multi-Unit Constraints.....	177
Chapter 11: Latency & Apollo	178
Delay Compensation with Apollo.....	178
Input Delay Compensation in Console	178
Latency Basics	181
Chapter 12: Device Drivers	184
Apollo Drivers Overview	184
Driver I/O Tables	185
Chapter 13: Glossary.....	195
Chapter 14: Index.....	202
Chapter 15: Notices.....	205

Chapter 1: Introduction



Welcome To The Apollo Family

High-Resolution Music Production with Classic Analog Sound

Designed to play a central role in modern studios, Apollo audio interfaces incorporate a true “no compromise” approach to audio quality. Building upon decades of UA’s analog hardware heritage, they offer extremely high-resolution sonics, with the lowest THD and highest dynamic range in their class. Apollo’s top-end converters — and UA’s meticulous attention to circuit design — translate into greater accuracy and depth in your recordings, from tracking and overdubbing, to mixing and mastering.

***Note:** Throughout this manual, “Apollo” refers to the entire Apollo family of audio interfaces (Apollo, Apollo 8, Apollo 8p, Apollo 16, Apollo 16 mkII, and Apollo Twin) unless specifically noted otherwise.*

Realtime UAD Plug-In Processing for Monitoring and Tracking

While Apollo’s “natural” sound is exceedingly open and transparent, it can quickly deliver a wide range of classic analog tones and color via its Realtime UAD Processing. Available with SOLO, DUO, or QUAD Core processing onboard, this onboard DSP Acceleration allows for recording and mixing through UAD Powered Plug-Ins — with as low as sub-2ms latency — so producers can quickly monitor, audition, and optionally “print” audio using classic analog emulations from API, Ampex, Lexicon, Manley, Neve, Roland, SSL, Studer, and more.*

***Important Fundamental Concept:** The primary function of Console is to control Apollo’s hardware input monitoring, Unison plug-ins, and Realtime UAD Processing. Console MUST be used to take advantage of these features. Console replaces the software input monitoring feature of the DAW mixer.*

* All trademarks are recognized as property of their respective owners. Individual UAD Powered Plug-Ins sold separately.

Apollo Software Features

Note: For a list of hardware features, see the [Apollo Hardware Manuals](#).

Console Application

General:

- Enables Realtime UAD Processing on Apollo inputs with indiscernible latency
- Analog-style mixer for low-latency monitoring and tracking with UAD plug-ins
- Remote control of Apollo hardware features and functionality
- Console sessions can be saved/loaded for instant recall of any configuration
- Multiple Undo/Redo for edit operations

Realtime UAD Processing:

- Up to four UAD plug-ins can be serially chained on each input and aux return
- UAD insert processing can be monitored “wet” while recording wet or dry
- Sub-2ms round-trip latency with four serial UAD plug-ins at 96 kHz sample rate

Channel Inputs:

- Input channels for all interface hardware inputs (*except MADI with Apollo 16*)
- Level, pan, solo, and mute controls on all inputs
- Four plug-in insert slots per input for Realtime UAD Processing
- Two stereo auxiliary sends with level and pan controls on all inputs
- Virtual inputs accept any outputs from DAW via device drivers
- Stereo headphone sends with level and pan controls on all inputs*
- Up to four stereo cue mix sends with level and pan controls on all inputs*
- Adjacent input pairs can be linked for convenient stereo control
- Sample rate conversion is available on S/PDIF and AES/EBU inputs*
- Any input can be routed to any output (*except Apollo Twin*)

Monitoring:

- Stereo monitor mix bus with level, mute, solo, ALT, dim, and source select controls
- Up to four independent stereo cue mix buses
- Flexible routing matrix for assigning cues to any available headphone and line outputs
- Independent monophonic sum controls for all mix buses
- S/PDIF and AES/EBU outputs can optionally mirror the post-fader monitor mix*

Auxiliary Buses:

- Two stereo auxiliary sends/returns with independent level, mute, and mono sum controls
- Four plug-in inserts per auxiliary return for Realtime UAD Processing
- Auxiliary buses can be routed to main monitor mix and/or cue outputs
- Independent pre/post switching on each auxiliary bus

**Specific software features depend on hardware functionality not available with all Apollo devices. Details within.*

Metering:

- Signal level meters with peak hold and clip indicators on all inputs
- Dual peak hold meters with signal peak LEDs display monitor bus levels
- Input meters are globally switchable to display pre or post fader signal levels
- Independently selectable peak/clip hold times and global clear clips button

Console Recall plug-in

- Convenient access to Console's monitor controls via DAW plug-in
- Saves complete Apollo configurations inside DAW projects for easy recall of settings
- VST, RTAS, AAX 64, and Audio Units plug-in formats

UAD Powered Plug-Ins

- Award-winning audio plug-ins for monitoring, tracking, mixing, and mastering
- UAD plug-ins can be used simultaneously within Console and/or DAW
- All UAD plug-ins include fully-functional 14-day demo period
- Complete UAD plug-ins library is available online at www.uaudio.com

UAD Meter & Control Panel application

- Configures global UAD-2 and UAD Powered Plug-Ins settings
- Facilitates automatic authorization of UAD plug-in licenses and UAD-2 devices

Device Drivers

- 64-bit device drivers, UAD plug-ins, and Console application
- Multi-unit cascading of up to four Apollo interfaces via Thunderbolt 1 or 2
- All hardware inputs and outputs can be individually addressed by DAW
- All of Console's mix buses can be routed to DAW inputs for recording
- Flex Driver feature for customizing Core Audio I/O routes and names

Apollo Documentation Overview

Documentation for all Apollo components is extensive, so instructions are separated by areas of functionality. Each functional area has a separate manual file. An overview of each file, and how they are accessed, is provided in this section.

***Note:** Extensive [Additional Resources](#), including technical information not available in other publications, is also available.*

Apollo Manual Files

***Note:** All manual files are in PDF format. PDF files require a free PDF reader application such as Preview (included with Mac OS X) or Adobe Reader.*

Apollo Hardware Manuals

Each Apollo model has a unique hardware manual. The Apollo hardware manuals contain complete hardware-related details about one specific Apollo model. Included are detailed descriptions of all hardware features, controls, connectors, and specifications.

***Note:** Each hardware manual contains the unique Apollo model in the file name.*

Apollo Software Manual

The Apollo Software Manual is the companion guide to the Apollo hardware manuals. It contains detailed information about how to configure and control all Apollo software features for all Apollo models using the Console application, Console Settings window, and Console Recall plug-in. Refer to the Apollo Software Manual to learn how to operate the software tools and integrate Apollo's functionality into the DAW environment.

***Note:** All Apollo models have the same software manual.*

UAD System Manual

The UAD System Manual is the complete operation manual for Apollo's UAD-2 functionality and applies to the entire UAD-2 product family. It contains detailed information about installing and configuring UAD devices, the UAD Meter & Control Panel application, buying optional plug-ins at the UA online store, and more. It includes everything about UAD except Apollo-specific information and individual UAD plug-in descriptions.

UAD Plug-Ins Manual

The features and functionality of all individual UAD Powered Plug-Ins is detailed in the UAD Plug-Ins Manual. Refer to this document to learn about the operation, controls, and user interface of each UAD plug-in that is developed by Universal Audio.

Direct Developer Plug-Ins

UAD Powered Plug-Ins includes plug-ins created by our Direct Developer partners. Documentation for these 3rd-party plug-ins are separate files written and provided by the plug-in developers. The file names for these plug-in manuals are the same as the plug-in titles.

Installed Documentation Location

All documentation is copied to the startup disk during software installation:

- Macintosh HD/Applications/Universal Audio

Accessing Installed Documentation

Any of these methods can be used to access installed documentation:

- Choose “Documentation” from the Help menu within the Console application
- Click the “View Documentation” button in the Help panel within the UAD Meter & Control Panel application
- Navigate the file system within the Mac OS X Finder
- Manuals are also available online: www.uaudio.com/support/manuals.html

Host DAW Documentation

Each host DAW application has its own particular methods for configuring audio interfaces and using plug-ins. Refer to the host DAW’s documentation for specific instructions about using audio interface and plug-in features within the DAW.

Hyperlinks

Links to other manual sections and web pages are [highlighted in blue text](#). Click a hyperlink to jump directly to the linked item.

Tip: Use the “back” button in the PDF reader application to return to the previous page after clicking a hyperlink.

Glossary

This manual uses technical terms and acronyms that may be unfamiliar. Refer to [“Chapter 13: Glossary”](#) for the definitions of many of these terms.

Apollo Software Overview

Apollo has several software components that comprise the complete Apollo system. A brief description of each component is provided below, along with a link to complete details about the component.

Console Application

The Console application is Apollo's primary software interface. Its main function is to control the hardware unit and its digital mixing and monitoring capabilities. The Console mixer is where Realtime UAD Processing using UAD Powered Plug-Ins is configured.

Important Fundamental Concept: *The primary function of Console is to control Apollo's hardware input monitoring, Unison plug-ins, and Realtime UAD Processing. Console MUST be used to take advantage of these features. Console replaces the software input monitoring feature of the DAW mixer.*

For an overview of the application, see [“Chapter 3: Console Overview”](#). For complete details, see [“Chapter 4: Console Reference”](#).

Console Recall Plug-In

Console Recall is a DAW plug-in supplied in VST, RTAS, AAX 64, and Audio Units formats. Console Recall offers additional convenience when using Apollo and/or the Console application in conjunction with a DAW. Its primary function is to store complete Console configurations within the DAW project file.



For complete details, see [“Chapter 7: Console Recall Plug-In”](#).

UAD Powered Plug-Ins

UAD Powered Plug-Ins are the software plug-in titles containing the DSP algorithms. UAD plug-ins are loaded within a host application for audio processing on Apollo's integrated UAD-2 DSP accelerator (Console and DAWs are host applications). Each UAD plug-in contains a graphical user interface (GUI) and various control parameters that can be manipulated to achieve the desired sonic results.



Typical UAD plug-in window

Apollo includes numerous UAD Powered Plug-Ins that are bundled with the device. Optional UAD plug-ins can be evaluated without functional limitations for 14 days in demo mode. Optional plug-in licenses can be purchased at the [UA online store](#).

For additional details about how UAD Powered Plug-Ins are used with Console and DAWs, see [“About UAD Powered Plug-Ins Processing”](#). For general UAD Powered Plug-Ins usage instructions, see the UAD System Manual. For complete details of individual UAD Powered Plug-Ins, see the UAD Plug-Ins Manual.

UAD Meter & Control Panel Application

The UAD Meter & Control Panel application is used to configure global functionality that pertains to all UAD-2 devices in the same system (the same application is used for all UAD-2 products). All UAD-2 global system settings are set within this application. The application also facilitates automatic authorization of UAD plug-in licenses and UAD-2 devices.

The application consists of two components: The UAD Meter and the UAD Control Panels.

UAD Meter

The UAD Meter window (at right) displays the current DSP and memory status of all active UAD-2 hardware (including multiple devices). These meters are also present at the bottom of the Console application window.



UAD Control Panels

The UAD Control Panel window has multiple panels that display, and enable control of, the various UAD-2 system, plug-in, and global configuration parameters.

The screenshot at right shows the System Info panel, one of four control panel windows in the UAD Meter & Control Panel application.

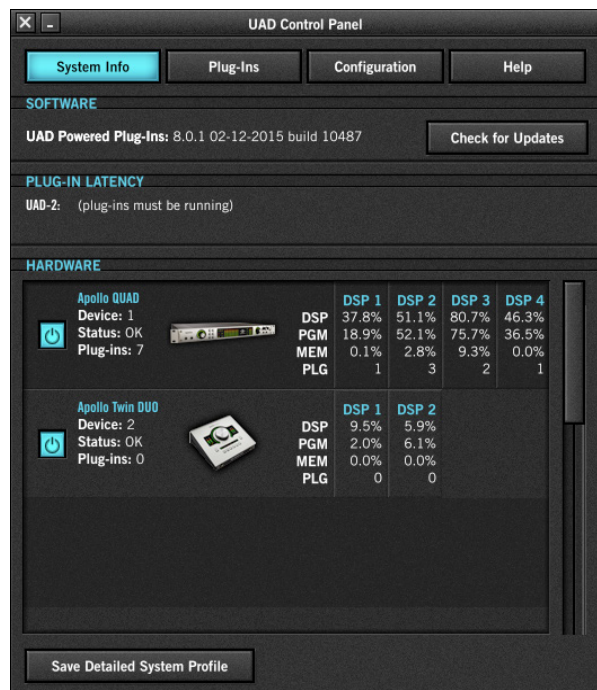

Accessing UAD Meter & Control Panel

The application can be accessed (after software installation) from the Mac OS X Dock.

Details About the Application

Complete documentation for the UAD Meter & Control Panel application is in the UAD System Manual.

Apollo Device Drivers

The Apollo device drivers are the low-level system software files that instruct the computer's operating system on how to communicate with the Apollo hardware. The drivers are loaded during system startup so whenever Apollo is connected, the interface is ready to accept instructions from the OS and audio applications. For complete details, see [“Chapter 12: Device Drivers”](#).

Technical Support

Universal Audio provides free customer support to all registered Apollo users. Support specialists are available to assist you via email and telephone during normal business hours, which are from 9 AM to 5 PM, Monday through Friday, Pacific Standard Time.

Email Support

To request online support via email, click the link below for a direct link to the help ticket form:

- <https://www.uaudio.com/my/support/create/>

Alternately, visit the main support page at www.uaudio.com/support, then click the blue “Submit Support Ticket” button on the right side of the web page to create a help ticket.

SUBMIT SUPPORT TICKET »

Telephone Support

USA toll-free:	+1-877-698-2834 (1-877-MY-UAUDIO)
International:	+1-831-440-1176
Germany, Austria, Switzerland:	+3-120-800-4912

Additional Resources

UA Support Videos

Many informational videos are available online to help you get started with Apollo:

- www.uaudio.com/support/thunderbolt

Apollo Support Page

The latest technical information for Apollo is posted on the Universal Audio website. The Apollo Thunderbolt support page contains updated, late-breaking information that is not available in other publications. Please visit this page for the latest news:

- www.uaudio.com/support/thunderbolt

UAD Users Forum

The unofficial UAD users forum, for the exchange of tips and information, is online at:

- www.uadforum.com

Chapter 2: Installation & Setup

Installation & Setup Overview

Simplified procedures for software installation, registration, and authorization are in this chapter. For complete and detailed procedures, refer to the [UAD System Manual](#). For hardware installation notes and wiring diagrams, refer to the [Apollo Hardware Manuals](#).

The UAD Installer places all the software necessary to configure and use Apollo and UAD Powered Plug-Ins onto the computer's startup drive. It also installs the Apollo hardware device drivers so the audio interface can communicate with the host computer. Therefore the UAD Installer must be run even if you intend to use Apollo's audio interface functionality without the use of Console or UAD Powered Plug-Ins.

System Requirements

- Apple Mac computer with available Thunderbolt or Thunderbolt 2 port
- Mac OS X 10.8.5 Mountain Lion, 10.9 Mavericks, or 10.10 Yosemite
- Four gigabytes available disk space
- Internet connection to download software and authorize UAD plug-ins
- Thunderbolt cable (*sold separately*)

Software Updates

The most recent UAD Powered Plug-Ins software version is always recommended so you'll have access to the latest UAD plug-ins and stability updates. The most recent software is available at the UA website: www.uaudio.com/downloads

Firmware Updates

For optimum results, always update the firmware if prompted by the software. The "Power Off UAD Device" dialog will appear after a firmware update is complete. Follow the instructions in the dialog to complete the process before attempting to use the software.

Preparation

Close all open files and applications before starting the software installation procedure. The installer requires a restart after installation.

If you are updating to a newer version of Apollo software or installing additional UAD devices, it is not necessary to remove the previous UAD software or hardware from the system.

Automatic Authorization

As of UAD v8.0, authorization is fully automatic. Simply restart the computer and authorization is accomplished automatically in the background.

Important: *Registration and authorization can only be accomplished after successful software installation.*

Software Installation

Software for Apollo and other UAD-2 devices (if any) must be installed at the same time. Software for UAD-2 devices cannot be installed separately.

Important: For optimum results, connect and power the Apollo hardware before installing the UAD software.

To install, register, and authorize the Apollo hardware and UAD plug-ins:

1. Connect Apollo to an available Thunderbolt 1 or Thunderbolt 2 port on the computer with a Thunderbolt cable.
2. Connect Apollo to AC power with the included power cable, then power on the device with the power switch.
3. Open the UAD Powered Plug-Ins software installer downloaded from the UA website:
www.uaudio.com/download
4. The UAD software installer will guide you. Restart the computer when prompted by the installer.



Note: If prompted to update the firmware, see the procedure below.

5. After restart, the default web browser launches and connects to the UA online store. Follow the instructions in the web browser to create an account, register the hardware, and authorize bundled UAD plug-ins.
 - After registration is complete, the UAD device is automatically authorized and the system is ready for use.
 - If the device was already registered, when the computer restarts the UAD Meter & Control panel automatically opens and UAD plug-ins are automatically authorized in the background.

Firmware Update Procedure

If prompted by the "Firmware Update" dialog window to update the Apollo firmware:

1. Click "Load" to begin the process. The "firmware is updating" window appears.
2. Wait for the "Power Off UAD Device" dialog window, which appears after the firmware is updated.
3. Power OFF Apollo, then power ON Apollo. The firmware update is complete.

Firmware Update Details

For complete details about Apollo firmware updates, visit the [firmware support page](#).

Chapter 3: Console Overview



Console's
application
icon

What is Console?

The included Console application is the software interface for Apollo audio interface hardware. Console's analog-style workflow is designed to provide quick access to the most commonly needed features in a familiar, easy-to-use application.

Console's function is to control up to four Apollo hardware units and their digital mixing and low-latency monitoring capabilities. Console is where Realtime UAD Processing and Unison with UAD plug-ins is configured and operated.

Important Fundamental Concept: *The primary function of Console is to control Apollo's hardware input monitoring, Unison plug-ins, and Realtime UAD Processing. Console MUST be used to take advantage of these features. Console replaces the software input monitoring feature of the DAW mixer.*

Console can be used simultaneously with a DAW for front-end signal processing and low-latency monitoring and/or tracking. Complete Console sessions can be saved as presets for easy recall of the entire configuration, or single channel strips can be saved/recalled using Channel Strip Presets. Console can also be used to configure Apollo's audio interface I/O settings such as sample rate, clock source, and reference levels.

The Console application is a remote interface to the digital mixing and signal processing functions that are performed within the Apollo hardware. Although Console runs on the host computer, the computer's CPU is not performing these audio functions. All signal processing occurs on the SHARC DSPs inside the hardware unit(s).

Note: *Apollo interfaces use UAD DSP and memory resources for its internal DSP mixer. Therefore, the UAD Meters will show DSP and memory usage when Apollo is connected, even if Console and/or UAD plug-ins are not currently loaded.*



The Console application's main window

Console Functions

Console enables the following functionality when used with Apollo:

- **Hardware control.** All of Apollo's front panel hardware controls (except headphone volume) can be controlled using Console, facilitating easy hardware manipulation even if Apollo is installed in a location out of reach of the computer operator.
- **Buffer-free monitoring.** Using Console eliminates the latency associated with DAW I/O buffering that makes monitoring problematic for the performer. By removing the DAW's "software input monitoring" feature from the monitoring signal flow altogether, the need to adjust I/O buffer sizes and latency is no longer an issue.
- **Realtime UAD Processing.** UAD Powered Plug-Ins can be inserted into all Console inputs and/or auxiliary returns (within available DSP resources), for the ultimate latency-free sonic experience while monitoring and/or tracking live performances. All processed (or unprocessed) mix buses, including the monitor, auxiliary, and cue buses, can be optionally routed into the DAW for recording.
- **Unison.** Apollo's Unison™ technology gives you the tone of the world's most sought-after tube and solid state mic preamps — including their all-important impedance, gain stage "sweet spots," and component-level circuit behaviors.
- **Send/Return Auxiliary buses.** Console has two pre/post stereo aux buses, with independent send levels per input, for grouped signal processing (conserving UAD DSP resources) or routing to the DAW.
- **Flexible cue monitor mixing.** Up to four independent stereo cue mix buses are available (two with Apollo Twin) with per-input sends to ensure individual performers are able to hear "more me" if desired. Cue mixes can be easily routed to any available headphone or line outputs.
- **Flexible signal routing.** Using Console, any hardware input can be routed to available hardware outputs (Apollo & Apollo 16 only). Additionally, cue mix buses can be optionally mirrored to available hardware outputs.
- **Session management.** Complete Console configurations can be saved and loaded to/from disk as presets, for convenient and unlimited session management. Sessions can also be stored/recalled within the DAW project using the Console Recall plug-in.

Global Settings

Parameters within the [Console Settings Window](#) are available for configuring various global behaviors:

- **Hardware.** Global interface settings such as sample rate, clock source, reference levels, and digital output mirroring.
- **Software.** Global software settings for Console such as metering and plug-in window behaviors.
- **Flex Driver.** This powerful feature enables customized signal routing and I/O naming at the Core Audio driver level. Custom driver routing tables can be saved and recalled as presets.

When To Use Console

The Console application can be used without a DAW, simultaneously in conjunction with a DAW, or not at all. These scenarios are covered in greater detail in [“Chapter 9: Working With Apollo” beginning on page 157](#).

Console without DAW. Console can be used by itself without the use of a DAW or any other audio software. Using Console without a DAW provides access to all Apollo functionality and simplifies the use of Apollo’s digital mixing, monitoring, and Realtime UAD Processing features when a DAW’s recording and playback features are not needed.

Console with DAW. Console is used at the same time as a DAW when low-latency monitoring and/or recording of Apollo’s inputs with (or without) Realtime UAD Processing is desired. In this scenario, Console is used as a “front end” to control input monitoring when recording, and the DAW’s software input monitoring feature is disabled. This workflow completely eliminates the I/O buffering latencies associated with using software monitoring via the DAW.

***Important:** To eliminate doubled signals, software monitoring in the DAW must be disabled when Console is used for input monitoring. Conversely, Console inputs must be muted if the DAW’s software monitoring feature is enabled.*

UAD plug-ins can be used within Console and a DAW simultaneously. In this scenario, Apollo’s DSP resources are shared between the two applications. Realtime UAD Processing is available via Console, and buffered (non-realtime) UAD processing is available via VST, RTAS, AAX 64, or Audio Units plug-ins within the DAW. See [“UAD Powered Plug-Ins: Console versus DAW” on page 157](#) for more details about this scenario.

***Tip:** Console can be opened or quit at any time, whether or not a DAW is already running.*

Interactions Between Console and Apollo

Console’s settings mirror the Apollo hardware. Changes made to one are also made on the other, and vice versa. If changes are made to Console when Apollo is not connected, then Apollo is subsequently connected, the Console settings are sent to the hardware.

***Important:** If Console is launched after changes are made to Apollo using the front panel hardware controls, the current Console settings will overwrite the changes made using the hardware controls.*

Accessing Console

Any of the methods below can be used to open the Console application.

- Select “Console” from the drop menu after clicking the blue UA logo diamond in the OS X Menu Bar (at upper right of screen).

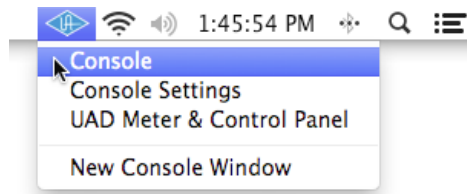

Accessing Console from the Mac OS X Menu Bar

- Click the Console application icon in the OS X Dock.



Accessing Console from the Mac OS X Dock

- Double-click the Console application icon in the OS X Finder, located at: /Applications/Universal Audio/Console.app

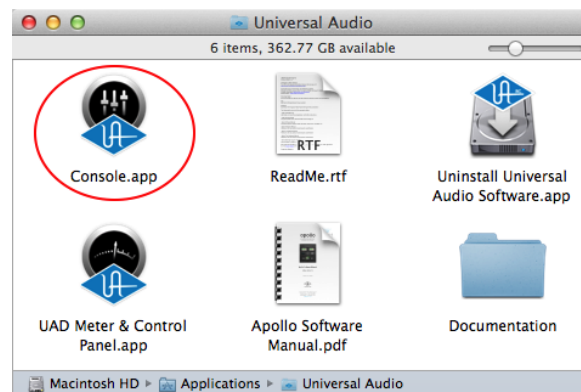

Accessing Console from the Mac OS X Finder

Quitting Console

Console can be closed using any of these methods:

- Select Quit from the Mac OS X Application Menu (upper left of screen) when Console is in the foreground
- Use the standard Mac OS X keyboard shortcut (Command+Q)
- Close all Console windows (via Close button in the [Window Title Bar](#))

Console Layout

Console’s visual and control elements are grouped according to functionality, with a layout similar to that found on typical analog mixers.

Detailed explanations of all the Console control functions are similarly grouped and presented later in [“Chapter 4: Console Reference”](#) beginning on page 45.

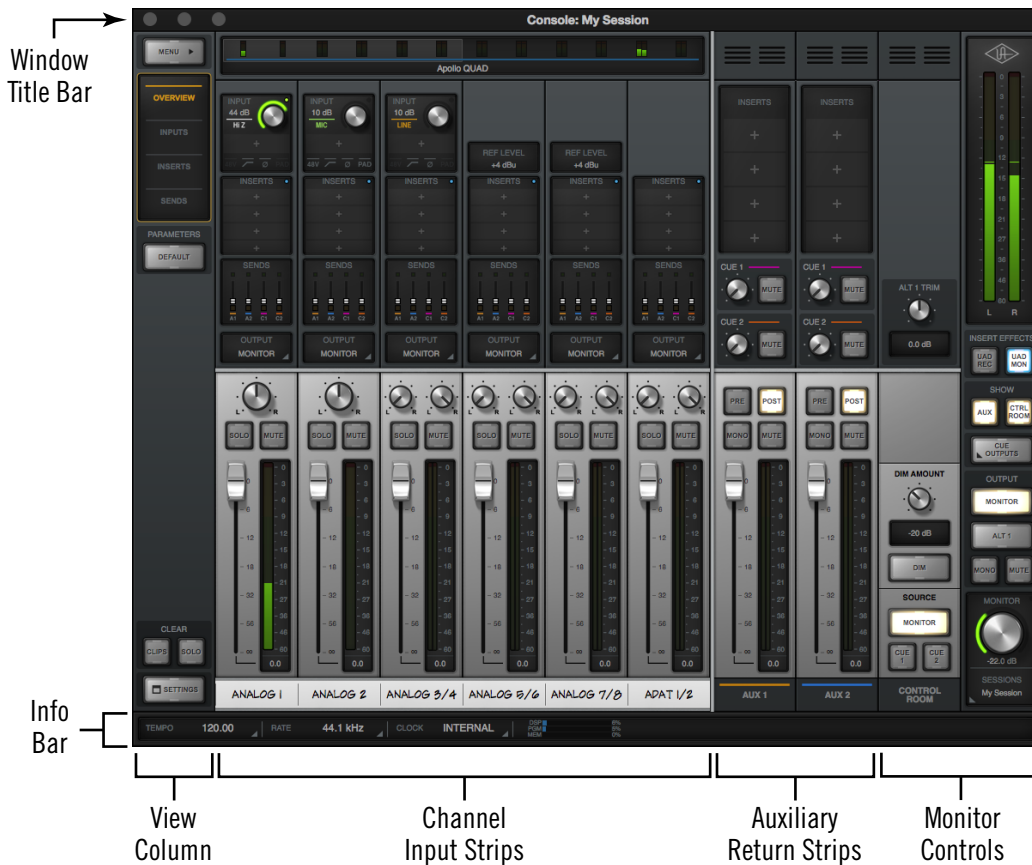

Console’s main window and controls layout

Dynamic Window Size

The size of Console’s high-resolution window can be dynamically adjusted in realtime to fit any workspace. To adjust the window size, clickdrag **any corner or any edge** of the window.

Width

Reducing the Console window width reduces the number of visible input channels. Use the [Bank Bar](#) in the [Meter Bridge](#) to view input channels that may be currently out of view.

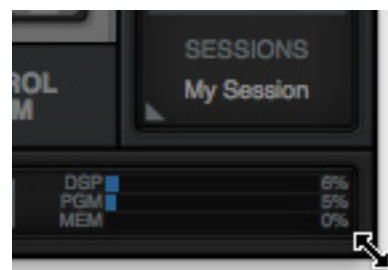

Drag any corner or edge to dynamically re-size the Console window

Height

When Console's window size is vertically adjusted, displayed elements are dynamically modified to fit available space. As the height is increased, some elements are enlarged for easier viewing and manipulation. As height is decreased, some elements are reduced.

Tip: All display and control elements are available regardless of window size.



Partial screenshots showing how control and display elements are changed with window size adjustments.

Above: The elements shown at left are more compact when vertical size is reduced.

Multiple Windows

More than one Console window can be open simultaneously and each open window can have unique views and sizes. Multiple displays are supported.

To open another window, choose “New Console Window” from the drop menu under the UA icon in the OS X Menu Bar at upper right of screen.

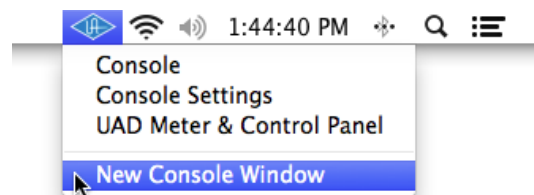

Opening an additional Console window

Global Window Elements

Some visual and control elements are always displayed in the Console window, while others depend on the current selection(s) in the *View Column* and *Monitor Column*, as illustrated below.

An brief overview of each global element is provided in this chapter. Detailed descriptions of all functions are provided in a later chapter.

The following elements are always visible in the Console window:

View Column	Meter Bridge
Monitor Column	Current Bank
Info Bar	Bank Bar (if channels out of view)

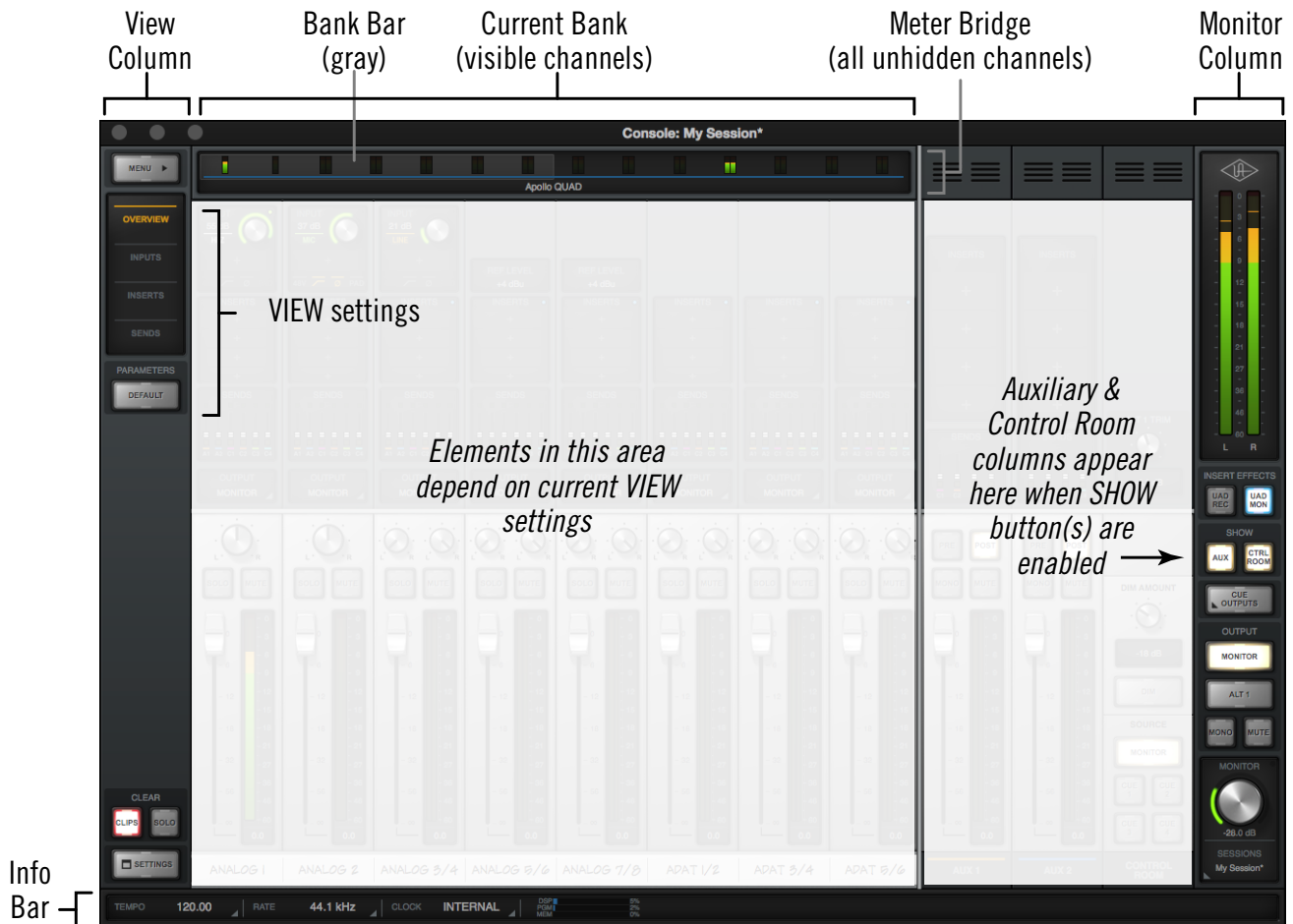

Console elements that are always visible

Meter Bridge Overview

The Meter Bridge (illustrated below) is always visible at the top of the Console window. It displays all non-hidden input channels, signal activity at these inputs, and the *Bank Bar*, which is used to scroll inputs that are out of horizontal view.

For detailed descriptions of all Meter Bridge elements, see [“Meter Bridge” beginning on page 45](#).

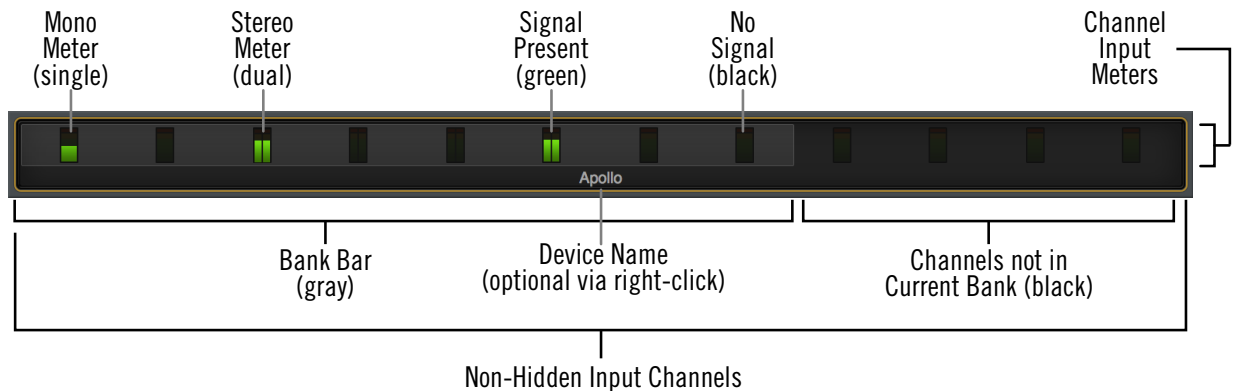

The Meter Bridge elements

Current Bank Overview

An important navigational concept in Console is the *Current Bank*. The Current Bank is all input channels that are currently displayed in the main body of the Console window (below the Meter Bridge) as shown in the illustration on the next page.

The gray Bank Bar is used to change the Current Bank. For complete details, see “[Current Bank](#)” beginning on page 46.

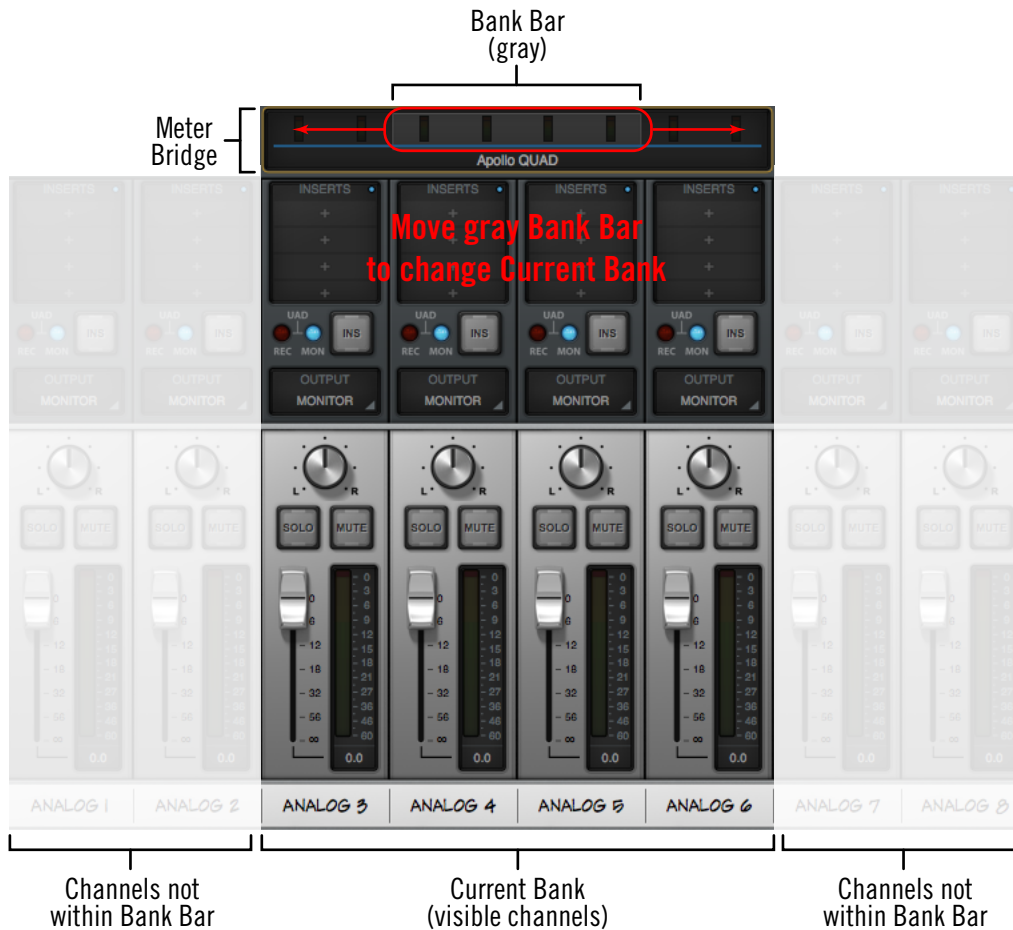

*Conceptual illustration of the Current Bank.
In this example, the Current Bank is analog channels 3 through 6.
Moving the Bank Bar brings different channels into the Current Bank view.*

View Column Overview

The View Column (illustrated at right) is always visible at the left side of the Console window. The View Column contains the Application Menu, View selectors, View Options, Clear switches, and Settings switch, as shown at right.

For detailed descriptions, see [View Column](#).

Views

Four Views are available in Console: Overview, Inputs, Inserts, and Sends. Each View displays related elements and associated functionality in the main area of the Console window.

View Selectors

To change the current View: Click the [View Selectors](#) in the View Column, select the View from the Application Menu, or use the [Keyboard Shortcuts](#).

View Options

The [View Options](#) activate various control functions within each View. The displayed View Options are contextual; some options change when a different View is selected.

Application Menus

Clicking the Menu switch presents the [Application Menus](#), where various Console functions are accessed.

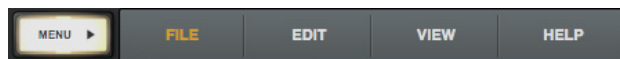

The Application Menus

Clear

The [Clear Switches](#) are used to reset all signal clipping indicators and turn off/on the solo function on all channels.

Settings

The Settings switch opens the [Console Settings Window](#), where various global functions are defined. Related functions are grouped within one of five available tabs in the window.

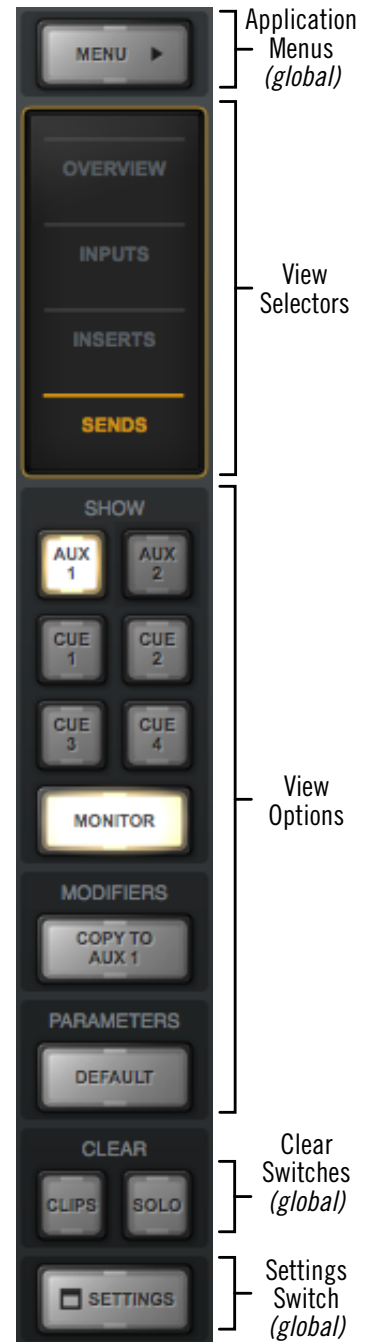

The View Column as it appears in Sends View

View Elements

Each View displays related elements and associated functionality in channel input strips within the main area of the Console window.

Note: The main monitor mix controls are the same in all views unless specifically hidden in Sends view.

The channel input elements of each view are shown below. Complete details for all elements are described in [“Chapter 4: Console Reference”](#) beginning on page 45.



Each View displays different elements in the input channel strips

Monitor Column Overview

The Monitor Column (illustrated at right) is always visible at the right side of the Console window. The Monitor Column contains elements related to monitor outputs, cue outputs, insert effect printing, and session file management, as shown at right.

For detailed descriptions, see [“Monitor Column” beginning on page 78](#).

Monitor Meters

These meters display the signal levels of the monitor mix bus just before the monitor level control. Levels displayed here mirror the state of the Monitor 1 – 2 LED meters on Apollo’s front panel.

Global Insert Effects

These switches globally switch all Console inputs to either pass all UAD insert effect processing to the DAW (print wet) or not (monitor wet but print dry).

Insert Effects can also be individually switched on a per-channel basis (see [“Channel Insert Effects” on page 103](#)). The Global Insert Effects switches override the individual channel settings.

Show Strips

These switches show and hide the visibility of the auxiliary return strips and/or the control room options strip. Each strip is visible when its SHOW switch is lit.

Cue Outputs Window

Clicking this switch opens the [Cue Outputs Popover](#), where the cue mix buses can be assigned and mirrored to available outputs.

Monitor Output Options

The monitor outputs can be muted and/or set to monophonic with these switches. When ALT monitoring is enabled, additional switches appear to control which output the monitor mix is routed to.

Monitor Level

This is the master level control for Apollo’s monitor outputs. It performs the same function as the MONITOR knob on Apollo’s front panel. When the ring around the knob is RED, the monitor outputs are muted.

Sessions Menu

Clicking this switch opens the Session Manager popover window, where Console configuration files are managed.

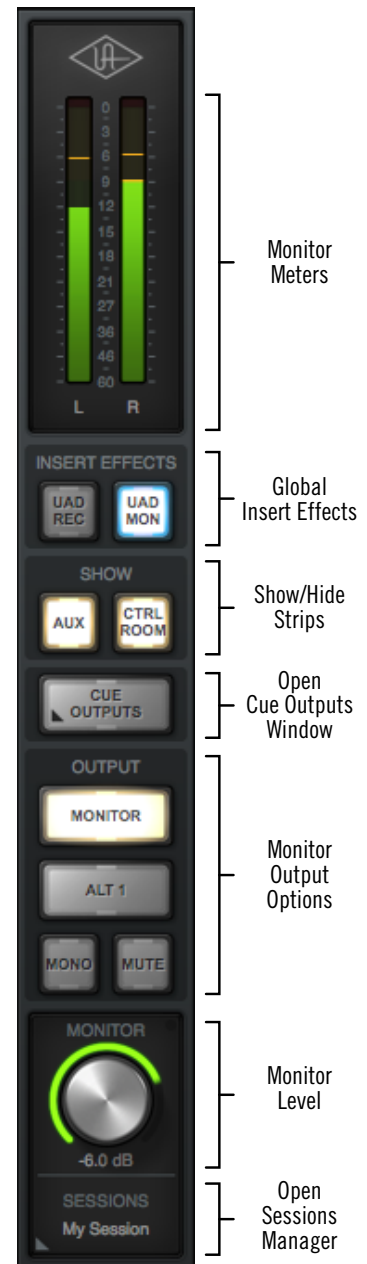

The Monitor Column

Info Bar Overview

The Info Bar (illustrated below) is always visible at the bottom of the Console window. It displays and provides access to several important functions.

Note: For detailed descriptions, see [“Info Bar” beginning on page 57](#).

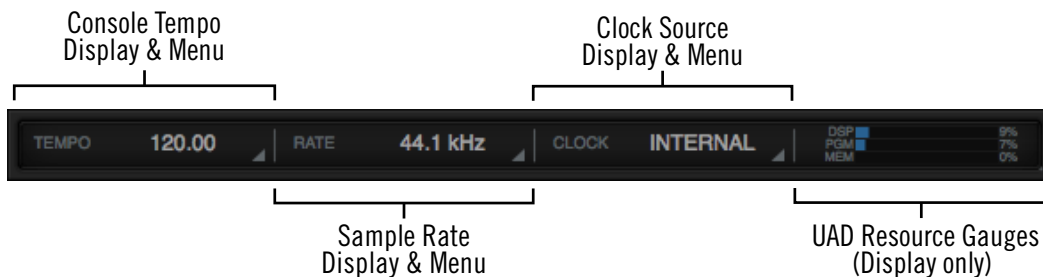

The Info Bar elements

Tempo

Console's current tempo is displayed here in beats per minute (BPM). The value is used by UAD plug-ins within Console that are set to use Tempo Sync. Click this area to enter or tap a different tempo.

Sample Rate

Apollo's current sample rate is displayed here. Click this area to select a different sample rate from the drop menu when using Console without a DAW.

Note: When using a DAW, the sample rate is managed within the DAW.

Clock Source

The active clock source (Internal, ADAT, S/PDIF, or Word Clock) is displayed here. Click this area to select a different clock source from the drop menu. This area flashes red if the currently selected clock is unresolved (when digital audio is not synchronized).

UAD Resource Gauges

This area displays DSP and memory resource loads used by all loaded UAD plug-ins (Console and DAW). UAD loads can be monitored as needed, for example when deciding which UAD plug-ins to load, based upon how much DSP is available.

Values displayed here are mirrored in the UAD Meter & Control Panel application. More detailed (per-SHARC) display of DSP usage is available in the System panel within the UAD Meter & Control Panel application.

Channel Strips Overview

Each Console channel input strip (illustrated at right) controls a corresponding Apollo hardware input. The output of all Console channel inputs are always routed to Console’s monitor outputs (except when muted). Inputs can be optionally routed to other outputs via [Flex Routing](#) or the [Cue Outputs Popover](#).

Console’s channel input strips are essentially the same for all inputs, however there are some differences among the analog and digital inputs as noted below.

Note: For detailed descriptions, see “[Channel Input Controls](#)” beginning on page 62.

Signal Flow

Audio signals in a Console channel flow through the inserts serially from top to bottom. Therefore, if more than one plug-in is inserted in a channel, the location of a plug-in within the inserts can impact the sound of the channel. Plug-ins can be reordered by dragging them to change the serial processing order.

Input Types

Console has analog, digital, and virtual inputs. The controls that are available in each strip depends on the type of input.

Analog Inputs

Preamp Inputs (Apollo, Apollo 8, Apollo 8p, Apollo Twin)

Each of Apollo’s preamp channels have multiple analog inputs (mic, line, Hi-Z) that can be selected with the preamp controls.

The preamp channels are switched between mic and line inputs manually via Console or Apollo’s front panel. Channels are automatically switched to Hi-Z inputs when a ¼” mono (tip-sleeve) cable is connected to Apollo’s front panel Hi-Z input jack.

Line Inputs (Apollo 16)

Console’s 16 analog line inputs reflect the 16 channels of A/D conversion that are available in Apollo 16. Apollo 16 does not have preamp channels.

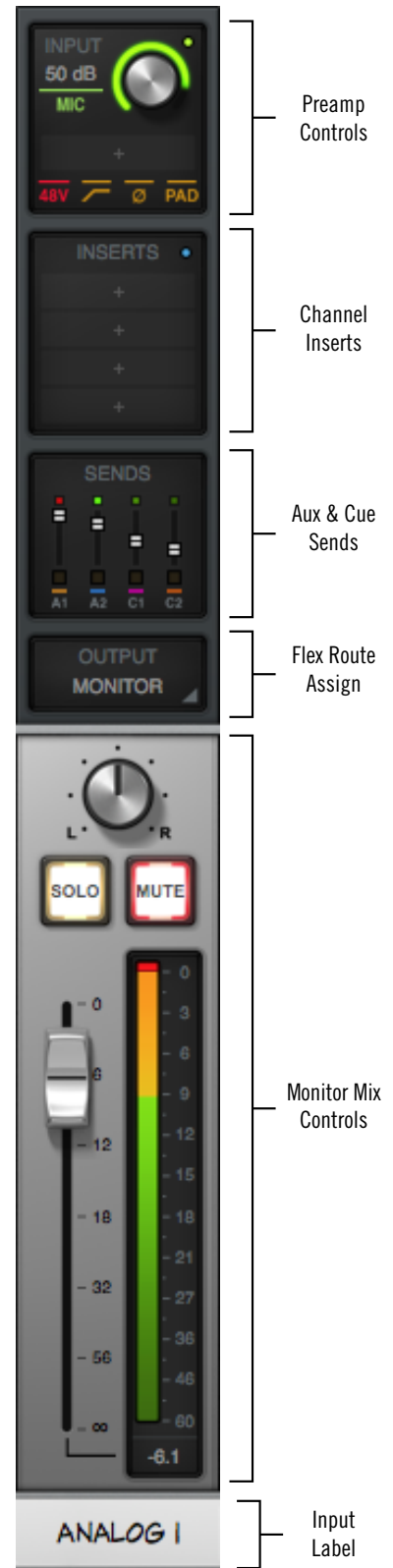

Channel Input Strip

Digital Inputs

Apollo, Apollo 8

Console's eight ADAT and two S/PDIF (stereo left and right) inputs work just like the analog inputs, except they don't have the extra preamp and reference level settings that are only available on the analog inputs.

Apollo 8p, Apollo Twin

Apollo Twin's digital TOSLink input can accept ADAT or S/PDIF. Console's inputs switch to reflect the digital input type currently in use (the digital input preference is set in the Console Settings window). The digital inputs work just like the analog inputs, except they don't have the extra the preamp and reference level settings that are only available on the analog inputs.

Apollo 16

Console has two AES/EBU inputs (left and right). MADI inputs are not available in Console.

Virtual Inputs

The virtual input channels in Console do not reflect Apollo's hardware inputs. Instead, they receive signals from DAW outputs via Apollo's device drivers, enabling Realtime UAD Processing on any DAW output. This feature is especially useful when playing virtual software instruments live through UAD plug-ins because it reduces I/O buffering latency. For complete details about this feature, see ["Virtual I/O" on page 169](#).

UAD Plug-In Inserts Overview

The UAD plug-in inserts within each input and auxiliary strip is where UAD Powered Plug-Ins are selected and used for Realtime UAD Processing.

Four inserts are available per Console channel strip; therefore up to four UAD plug-ins can be serially chained (stacked) per input within the constraints of available DSP resources.

Note: For complete details, see [“Chapter 5: UAD Plug-In Inserts”](#) beginning on [page 99](#).

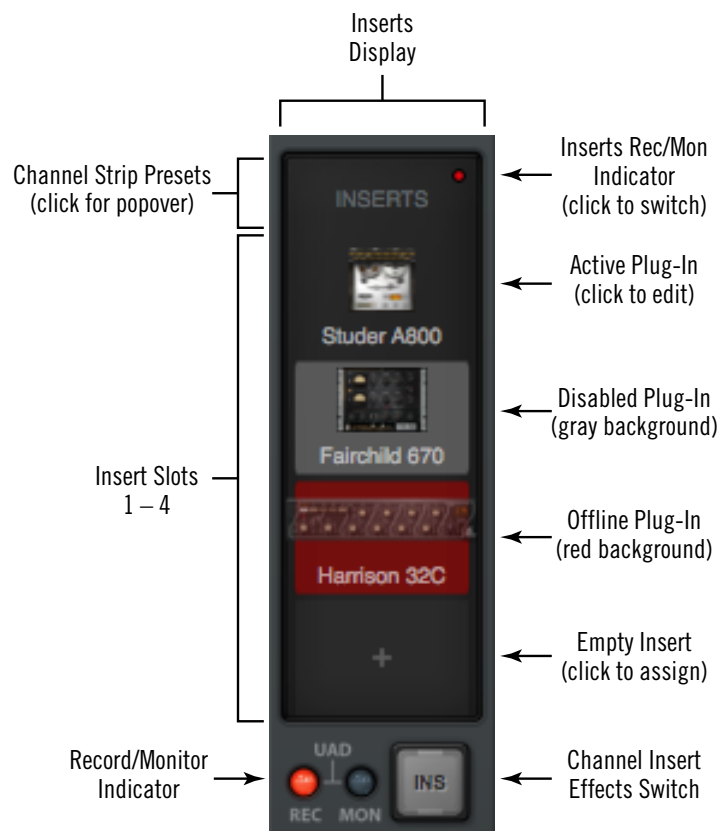

The Channel Inserts

Unison Insert

Apollo's Unison technology is activated when a Unison-enabled UAD plug-in is loaded in the dedicated Unison insert slot located above the preamp options (as shown at right, outlined in red).

Note: Audio on preamp channels is processed by the Unison insert (if active) before the channel inserts.

The Unison insert is only available on Apollo preamp channels. However, Unison inserts are operated exactly the same way as standard channel inserts. See the [Unison](#) chapter for related information.



The Unison Insert

Console Settings Overview

Global parameters for Apollo and Console are configured in the Console Settings Window.

Note: For complete details, see “Chapter 6: Console Settings” beginning on page 115.

Console Settings Panels

Controls within the Console Settings window are arranged according to related functionality. Each set of related controls are contained within a single panel.

Five panels are available in the Console Settings window:

Hardware – Settings related to Apollo hardware device setup

Core Audio – Settings related to Flex Driver and custom driver I/O mapping

Display – Settings related to how and what items are displayed in Console

Plug-Ins – Settings related to UAD plug-ins used within Console

MIDI – Settings for configuring MIDI control of Tap Tempo within Console

Accessing Console Settings

The Console Settings window can be opened using any of these methods:

- Choose View>Settings from the [Application Menus](#)
- Choose Console Settings under the UA icon drop menu in the Mac OS X Menu Bar

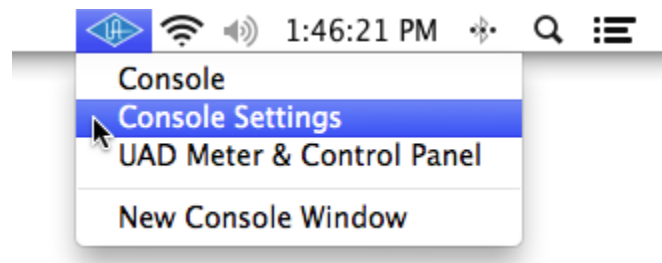

Accessing Console Settings from the Mac OS X Menu Bar

- Click the SETTINGS switch at the bottom of the [View Column](#)
- Use the “command-comma” keyboard shortcut

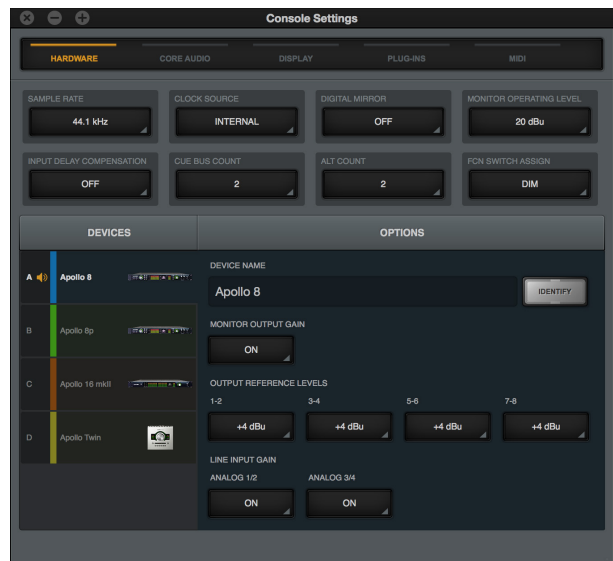
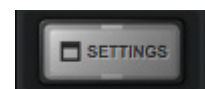

The Hardware panel within the Console Settings window

Insert Effects Overview

The Insert Effects settings are used to specify whether or not Realtime UAD Processing in Console is recorded (printed) in the DAW.

- Console inputs are recorded with processing (wet) when Insert Effects are active. The UAD-processed signals are heard and recorded.
- Console inputs are recorded without processing (dry) when Insert Effects are inactive. The UAD-processed signals are heard, but not recorded.

Important: *UAD plug-in processing in Console's Unison insert and auxiliary inserts are always routed to the DAW, regardless of the current Insert Effects setting (Unison and aux insert processing is always recorded).*

Function of the Insert Effects Switch

The Insert Effects switch determines if the DAW records Console's inputs with or without Realtime UAD Processing, regardless of the actual wet or dry state of the monitor mix. This is accomplished by routing Console's inputs into the DAW from before the plug-in inserts (dry recording) or after the plug-in inserts (wet recording).

Record With Effects

When Insert Effects are record-enabled, Apollo's hardware input signals are processed by Console's UAD plug-in inserts before routing into the DAW.

In this mode, the post-insert (wet) state of all Console inputs with Realtime UAD Processing is routed to the DAW inputs.



Note: *This setting is used to record "wet" with Realtime UAD Processing.*

Monitor With Effects

When Insert Effects is *not* record-enabled, Apollo's hardware input signals are routed directly into the DAW *before* being processed by Console's UAD plug-in inserts.

In this mode, the pre-insert (dry) state of all Console inputs is routed to the DAW inputs, even if Realtime UAD Processing is occurring in the monitor mix.

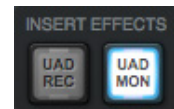

Note: *This setting is used to record "dry" when Realtime UAD Processing is active.*

Individual Channel Insert Effects

Insert Effects can be recorded wet or dry on a per-channel basis. For details, see [Channel Insert Effects](#).

Global Insert Effects

Insert Effects for all channels can be globally switched to override the individual channel insert effect switches. For details, see [Global Insert Effects](#).

Cues Overview

The cue mix buses are used to create unique mixes that are separate from the main monitor mix. Cues are typically used for performers that want to hear a headphone mix that is different from the main monitor mix, sending separate mixes to other rooms or audio equipment, and similar applications.

In addition to the main monitor stereo mix bus and the two auxiliary stereo mix buses, Apollo features up to four stereo cue mix buses (two with Apollo Twin) that can be used for a variety of signal routing purposes.

Cue Labels

The cue labels vary per Apollo device model, as described below.

Apollo, Apollo 8, Apollo 8p, Apollo 16 – The cues are labeled CUE 1, CUE 2, CUE 3, and CUE 4 respectively.

Apollo Twin – With Apollo Twin, the two cues are labeled HP (headphone) and LINE 3/4 (line outputs 3 and 4) to reflect the available hardware outputs on the device.

Cue Components

The complete cue system is comprised of the cue mix buses, the cue sends, and the cue outputs.

Cue Mix Buses – A cue mix bus is the summed stereo mix of individual audio signals. Signals are routed into the cue mix buses via the cue send controls, and returned from the cue mix bus via the cue outputs controls.

Cue Sends – The cue sends adjust the individual channel signals going into the cue mix bus. Each input channel and aux return contains individual level, pan,* and mute controls for each active cue mix bus. All cue sends are pre-fader and pre-mute so they are not affected by adjustments to the main monitor mix.

**Note: If two input channels are stereo-linked, the cue sends on the stereo pair cannot be panned. Sends for stereo channels are hard-panned left and right.*

Cue Outputs – Cue mix buses are returned via the Cue Outputs window, which is a matrix for routing the cues to Apollo's available hardware outputs.

Cue Monitoring – Available cue outputs also can be selected as a source for the main monitor outs via the [Monitor Output Options](#), enabling any cue mix bus to be heard in the main monitor speakers.

Cue Count

By default, two cues are displayed in Console (four with Apollo 16). Up to four cues are available with Apollo by increasing the [Cue Bus Count](#) in the Hardware panel within the Console Settings window.

Sends Overview

Apollo has a maximum of seven stereo mix buses (five with Apollo Twin) that are configured and adjusted within Console.

The stereo buses are used for the monitor, auxiliary, and cue mixes. Each Apollo input has independent level, pan, and mute controls for each of the stereo mix buses.

Stereo Mix Buses

In addition to the main monitor mix, the following stereo mix buses are available:

Auxiliary

The two aux buses are typically used for shared effect processing (to reduce UAD resource usage) for realtime monitoring with time-based effects such as reverb and/or delay. The aux mixes are adjusted via each input's two aux send controls.

By default, the aux sends are post-fader and post-mute. The aux sends can be switched to be pre-fader and pre-mute. The [Aux Pre / Aux Post](#) function switch for each aux is located in its respective auxiliary bus return strip.

Cues

The cue buses are for creating mixes that are different from the main monitor mix. Cues are typically used for performers that want to hear a headphone mix that is different from the main monitor mix, or for routing individual channels or mixes to other equipment.

The cue mixes are adjusted via the cue sends on each input and aux strip. All cue sends are pre-fader and pre-mute so they are not affected by adjustments to the main monitor mix.

Note: *By default, two cues are displayed in Console (four with Apollo 16). Up to four cues are available with Apollo by increasing the [Cue Bus Count](#) in the Hardware panel within the Console Settings window.*

Mix Bus Returns

The stereo mix bus returns are used to route the mix to available outputs.

Auxiliary

The aux mixes are routed to the aux return strips. Cue sends are available on the aux returns for routing aux effects to the cue mix buses.

See [“Aux Returns” beginning on page 75](#) for details.

Cues

The cue mixes are heard via the selections in the monitor controls section. Cues are routed to available Apollo outputs via a matrix in the Cue Outputs window. The Monitor outputs can be switched to output any cue mix instead of the monitor mix.

For cue return details, see [“Cue Outputs Popover” beginning on page 82](#).

Sends Access

The Sends can be accessed and adjusted in the Overview and Sends views.

Note: *Sends are not visible in the Inputs and Inserts views.*

Overview View

An overview of an input’s sends state is shown in each input channel strip, as shown below. Clicking this overview opens the [Sends Popover](#), where the sends can be adjusted. If the Console window is vertically re-sized tall enough, individual send knobs appear in place of the sends overview.

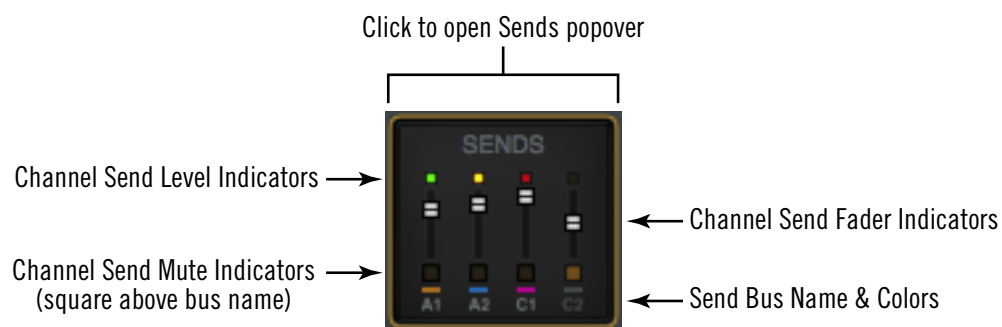

The Sends Display within each input channel strip in Overview view

Sends View

A single send is displayed for all channels simultaneously in Sends View. The displayed send is selected with the SHOW buttons in the View column. Sends view offers long-throw faders for finer control resolution.

Tip: To increase the Send control's resolution when in Sends view, increase the vertical size of the Console window and/or deactivate the SHOW MONITOR button in the View column.



In Sends view, the same send is visible on all inputs. Clicking the available SHOW switches displays the different sends.

Show All Sends Option

All sends can be viewed simultaneously by holding the Option key (on computer keyboard) while clicking any SHOW switch in Sends View.



All sends are visible when a SHOW switch is option-clicked

ALT Monitoring Overview

Apollo features ALT (alternate) monitoring capabilities. ALT monitoring can be used to control alternate pair(s) of monitor speakers, which is convenient for quickly comparing how a mix sounds through a different set of speakers. Up to two pairs of ALT monitors can be used (one pair with Apollo Twin).

ALT monitoring is enabled in the [Hardware Settings Panel](#) within the Console Settings window by increasing the [ALT Count](#) setting to a non-zero value.

ALT Monitor Connections

Note: The ALT channel output assignments cannot be modified.

Apollo, Apollo 8, Apollo 8p Apollo 16 – The ALT 1 monitor signal is routed to line outputs 1-2, and the ALT 2 monitor signal is routed to line outputs 3-4.

Apollo Twin – The ALT monitor signal is routed to line outputs 3-4 with Apollo Twin.

ALT Monitor Trims

Each pair of ALT outputs has its own trim (gain) setting, which is used to offset any volume level differences with the volume level of the main monitor speakers.

As the monitor level is adjusted, these offsets are maintained so speakers can be accurately compared at any volume. The ALT trims are located in the [Control Room Column](#).

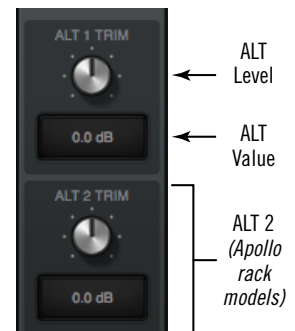

ALT trims

ALT Monitor Select

The ALT monitors are selected in the OUTPUT section of the [Monitor Column](#). The number of ALT output switches that appears here depends on the [ALT Count](#) setting.

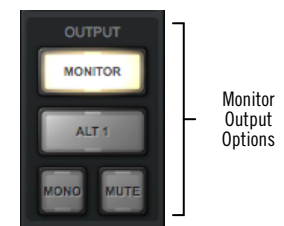

ALT selector

ALT Monitor Volume & Mute

The monitor level knob adjusts the output volume and muting of both the ALT monitors and the main monitors.

ALT Monitor Knob Color

The colored ring around the Monitor Level knob indicates the active ALT selection, as shown at right.

Green – Main monitor outputs are active

Orange – ALT 1 outputs are active

Yellow – ALT 2 outputs are active



Console Sessions Overview

The Sessions controls provide methods for managing complete Console configurations as session preset files. When a Console session file is saved, the current Console configuration is written to disk.

When a session file is subsequently reloaded, Console is returned to the exact same configuration state, regardless of any changes to Console that were made in the interim.

Note: Monitor settings, hardware settings, and Console input labels are global parameters that are not saved in session files.

For complete details, see [“Console Sessions” beginning on page 87](#).

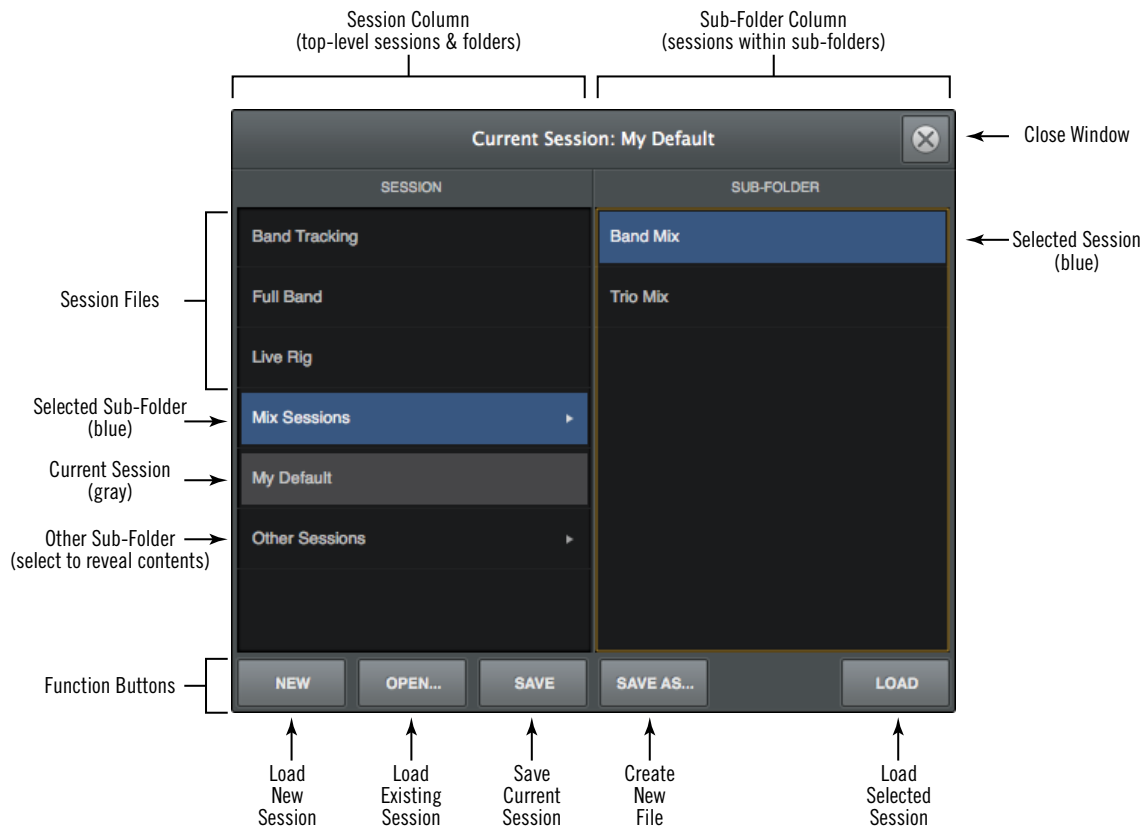

The Sessions Manager popover

Flex Driver Overview

Apollo's powerful Flex Driver feature allows enables virtual mapping of I/O routes, channel counts, and labels at the [Core Audio](#) driver level. For complete Flex Driver details, see [“Core Audio Panel” beginning on page 125](#).

Important: Custom driver I/O routing changes the driver I/O complement. Quit all audio applications before changing driver I/O assignments.

Custom I/O Maps – With Flex Driver, it's possible to remap Apollo's driver inputs/outputs to any Core Audio inputs/outputs, offering the ultimate in I/O routing flexibility when using any DAW.

Custom I/O Names – The driver labels for Apollo's I/O can be renamed so DAW inputs and outputs can use custom names. With Flex Driver, channel input and output selectors within a DAW can be (for example) “Neve 1073” instead of “Input 1.”

Custom Channel Counts – Some DAWs restrict the number of I/O channels that can be used. With Flex Driver, it's possible to specify exactly which I/O is seen by the DAW, even if the available Apollo I/O exceeds the DAW's maximum channel I/O count.

Custom I/O Presets – Customized I/O tables can be saved and loaded to or from disk as presets for future recall and/or sharing with other Apollo users.

Core Audio Panel – The Core Audio panel is the software interface for Flex Driver. This is where Apollo's I/O can be renamed, remapped, and saved for future use.

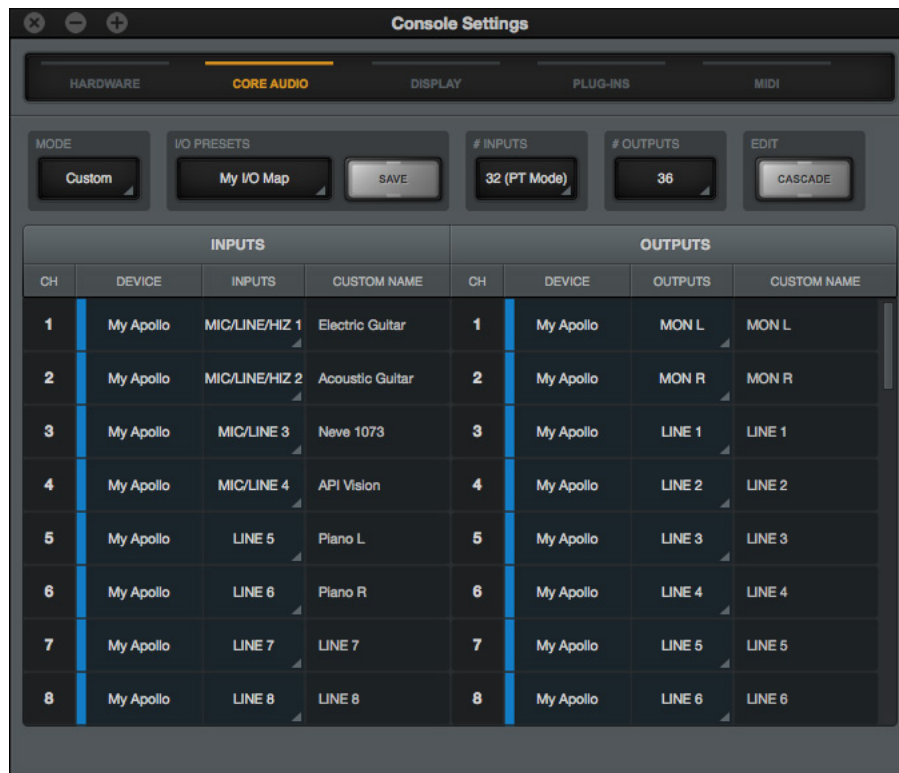

The Flex Driver feature is configured in the Core Audio settings panel

Popover Windows

Some Console functions that are not visible in the main window are accessed in popover windows. Popovers are a special type of window that automatically close when any area outside of the popover is clicked.

Note: The size of popover windows cannot be adjusted.



To close any popover, click anywhere outside of the popover, press the “X” switch at upper right of the window, or type the “esc” (escape) key on the computer’s keyboard.

The following functions are accessed via popover windows:

Cue output assign	Channel presets
Rename/link channel inputs	Console session presets
Sends (Aux & Cue)	Flex Route assign
Insert assign	Flex Driver assign
Plug-in presets	Flex Driver I/O presets

Multiple Undo/Redo

Console supports multiple levels of Undo and Redo for all edit operations. Undo and Redo operations can be performed repeatedly to step backwards and forwards through edit operations as long as the current session is open.

- To step backwards and undo (revert) edit operations, choose Undo from the [Edit Menu](#) or type command-z.
- To step forwards and re-execute the edit, choose Redo from the [Edit Menu](#) or type command-shift-z.

Undo/Redo Cache

Edits are stored in the Undo/Redo cache. Edits within a particular session can be reverted with Undo/Redo until the cache is cleared. Both of these operations will clear the Undo/Redo cache:

- Console is quit
- A different Console session is loaded

Important: Prior Undo/Redo operations cannot be performed after the Undo/Redo cache is cleared.

Keyboard Focus & Control

Many Console functions can be controlled without using a mouse. When elements on the screen have keyboard focus, they can be quickly navigated with the computer's QWERTY keyboard.

Focus Indication

Keyboard focus in Console is indicated by a orange-colored highlight box outlining the screen elements that are targeted for keyboard control.

Focus Navigation

Focus between elements can be changed with the computer's TAB key, or by clicking another area of the screen with the mouse.

Focus Control

Focused items can be selected by using the up/down/left/right arrow keys and/or the Return/Enter keys.

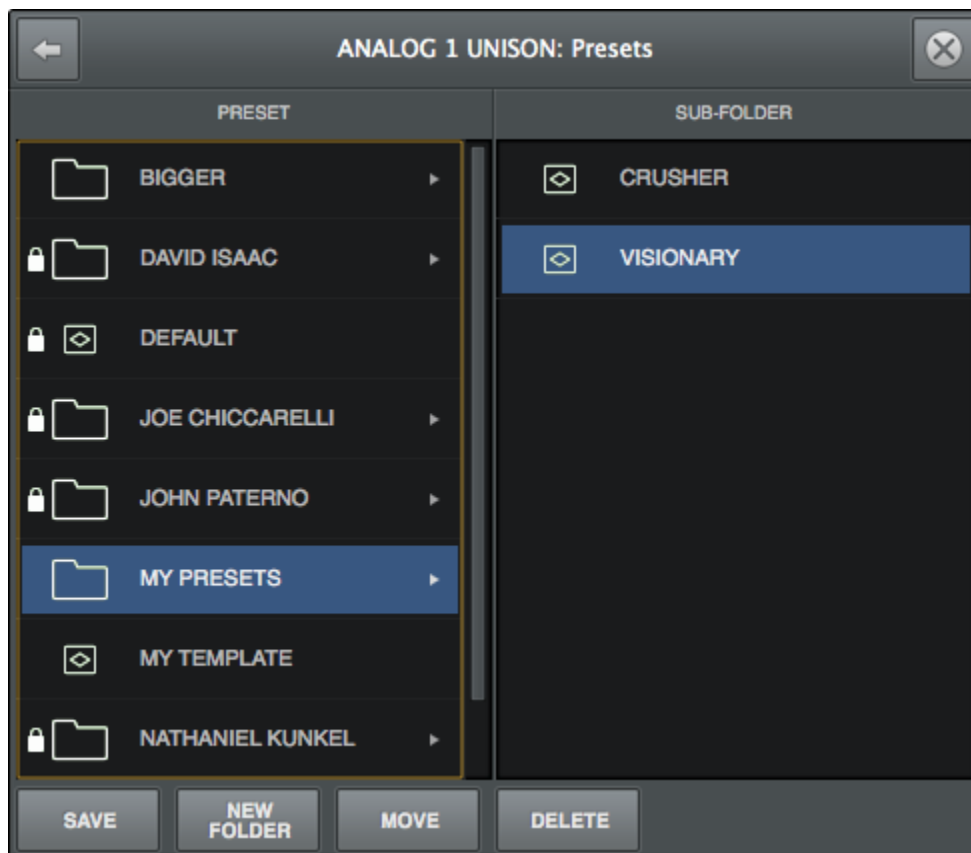

Typical focus indication. The PRESET column on the left has focus (orange outline) and can be navigated with the up/down arrow keys on the keyboard. The tab key alternates focus between the two columns.

Adjusting Console Controls

Console uses typical software control techniques to adjust parameters.

2-state switches: Click to toggle the state.

Knobs: Click+drag to adjust, or use the [Controls Shortcuts](#). Console's rotary controls (and UAD plug-in knobs) can respond to Linear, Circular, or Relative Circular adjustments modes. The CONTROL MODES preference is set in DISPLAY panel within the Console Settings window.

Faders: Click+drag to adjust, or use the [Controls Shortcuts](#).

Drop Menus: Click to view the drop menu contents, then click an item in the drop menu to select the item.

UAD Powered Plug-Ins: Most UAD plug-in controls use the same methods as above. However, some plug-in parameters may have custom controls that are unfamiliar or not obvious. All custom controls are detailed for individual plug-ins in the [UAD Plug-Ins Manual](#).

Controls Shortcuts

In addition to the keyboard shortcuts below, several other shortcuts are available to simplify Console control adjustments:

Fine Control: Continuous controls (knobs and faders) can be adjusted with increased resolution by depressing the SHIFT while adjusting these controls.

Scroll Wheel: Continuous controls (knobs and faders) can be adjusted by using the computer input device's scroll function (e.g., mouse scroll wheel). Hover the cursor over the control and adjust the scroll wheel to modify the parameter value.

Adjust All: If the Option key is held down while modifying any control, the same control on all inputs (or aux returns) will be simultaneously adjusted. The relative difference is maintained between the same controls until any control reaches its minimum or maximum value.

Return To Default: If the Command key is held when a control is clicked, the control will return to its default value. Command+Option+Click will return all controls of the same type to their default value.

Mute/Solo All Toggle: Option-click a Mute or Solo switch to toggle the state on all channels.

Drop Menus: Menus continue to display after a single click. The mouse button does not need to be held down to view the menu.

Keyboard Shortcuts

Console supports the keyboard shortcuts listed in the table below.

Shortcut Name	Keyboard Command	Description
New Session	Command-N	Create a new default session
Open Session	Command-O	Load an existing session file from disk
Save Session	Command-S	Save current session file to disk
Save Session As...	Command-Shift-S	Save current session as new file with optional rename
Hide Application	Command-H	Hide application from view
Quit Application	Command-Q	Quit Console application
Overview	Command-1	Switch main view to OVERVIEW
Inputs	Command-2	Switch main view to INPUTS
Inserts	Command-3	Switch main view to INSERTS
Sends	Command-4	Switch main view to SENDS
Show/Hide Inputs	Command-I (the letter i)	Activate Show/Hide Inputs modifiers
Focus Navigation	Tab	Cycle through orange-outlined areas that can be focused/controlled/navigated with the arrow keys
Element Navigation	Left/Right/Up/Down (arrows)	Select focused elements with the arrow keys
Cancel Dialog	ESC (escape)	Cancel dialog functions such as Plug-In Assign, Preset Select, Save As, etc.
Confirm Dialog	Return or Enter	Accept dialog functions such as Plug-In Assign, Preset Select, Save As, etc.
Settings Window	Command-, (comma)	Open Console Settings window
Undo Edit	Command-z	Revert the last executed function (multiple Undo possible)
Redo Edit	Command-shift-Z	Revert the last executed Undo (multiple Redo possible)

Apollo Model Differences

Apollo, Apollo 8, Apollo 8p, Apollo 16, Apollo 16 mkII, and Apollo Twin have different hardware features, and the Console software automatically reflects these differences. The Console interface elements that appear depends on which Apollo hardware model(s) is connected to the computer. Any Console feature differences are specifically noted in this manual.

Note: In this manual, “Apollo” refers to all Apollo interface models unless specifically noted otherwise, and “Apollo 16” refers to both the original Apollo 16 model and the newer Apollo 16 mkII model.

Apollo Rack Models

Some Console features apply to Apollo rack models only (all models except Apollo Twin, which has a desktop form factor). In this manual, all specific references to “Apollo Rack Models” apply to Apollo, Apollo 8, Apollo 8p, Apollo 16, and Apollo 16 mkII models only.

Chapter 4: Console Reference

This chapter provides in-depth descriptions of all controls within Console. For a general operational overview, see [“Chapter 3: Console Overview”](#) beginning on page 16.

Meter Bridge

The Meter Bridge is always visible at the top of the Console window. It displays all visible input channels, signal activity at these inputs, and the *Bank Bar*, which is used to scroll inputs that are out of horizontal view.

Refer to the diagram below for descriptions in this section.

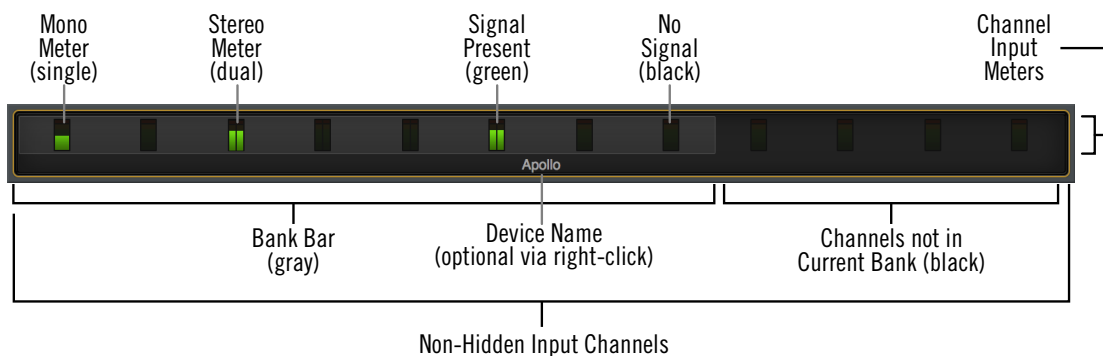

The Meter Bridge elements

Input Channels

The Meter Bridge represents all Apollo input channels. When an input channel is hidden with the [Show/Hide Inputs](#) function, that channel is not displayed in the Meter Bridge.

Channel Meters

Each vertical green meter represents input signal activity in the channel. These small meters mirror the activity of each high-resolution [Input Meter](#) that is displayed next to each channel's [Input Fader](#).

Bank Bar

When the Console window does not have enough available horizontal space to display all available input channels, the gray Bank Bar appears within the Meter Bridge.

The Bank Bar “floats” on top of all input channels in the Meter Bridge. The Bank Bar is used to change the channels that are visible within the Current Bank.

Note: *The Bank Bar is not displayed when all available input channels are visible within the Console window.*

Current Bank

The Current Bank is all input channels that are currently displayed in the main body of the Console window (below the Meter Bridge) as shown in the illustration below. The gray Bank Bar is used to change the Current Bank.

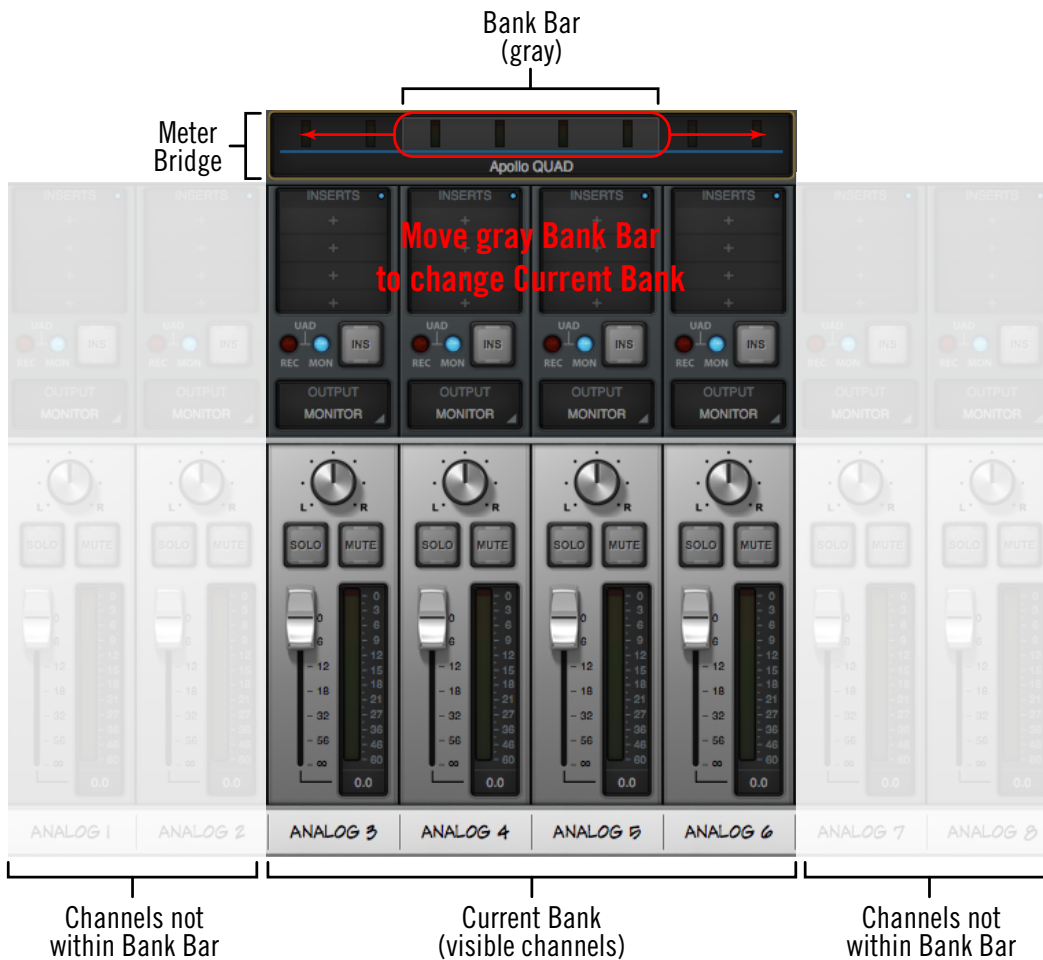

Conceptual illustration of the Current Bank.

In this example, the Current Bank is analog channels 3 through 6.

Moving the Bank Bar brings different channels into the Current Bank view.

Changing the Current Bank

Any of these methods can be used to change the channels within the Current Bank:

Click – Click anywhere within the Meter Bridge, but outside of the Bank Bar. The Bank Bar jumps to the channel that is clicked in the Meter Bridge.

Drag – Click-hold-drag the gray Bank Bar to slide it across available channels.

Hover Scroll – Position the mouse over the Meter Bridge then scroll horizontally with the computer's input device.

Arrow keys – When the Bank Bar has keyboard focus, use the computer's left/right arrow keys to navigate the Current Bank.

Meter Bridge Menu

The Meter Bridge menu provides access to various functions related to the Meter Bridge. To view the menu, right-click (or control-click) within the Meter Bridge.

Most functions in the menu are available elsewhere within Console. Show/Hide Offline Devices is available exclusively within this menu.

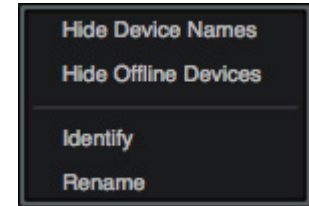

Show/Hide Device Names – See [Show Device Names](#).

Show/Hide Offline Devices – Devices in the Hardware panel within the Console Settings window that are not currently connected are displayed in the Meter Bridge by default. To show/hide offline devices, choose this item from the menu.

Identify – See [Identify](#).

Rename – See [Device Name](#).

View Column

Note: For an overview of Console's View Columns, see [“View Column Overview”](#) beginning on page 25.

The View Column is always visible at the left side of the Console window. The View Column contains the View Selectors and switches for the View Options (functions) available within each view.

Each View Column also contains several common view elements that are available in every View.

Available Views

Four Views are available in Console (Overview, Inputs, Inserts, Sends). Each View displays related elements and associated functionality in the main area of the Console window.

Common View Elements

Most display and control elements that appear within the main Console area (see [Global Window Elements](#)) in each View are common to all the Views.

Therefore, the common elements are detailed separately from the View Column descriptions.

View Selectors

Any of these methods can be used to change the current View:

- Click any View Selector in the View Column
- Choose the View from the [Application Menu](#)
- Use the keyboard shortcuts (⌘1, ⌘2, ⌘3, ⌘4)

View Column Options

The View Options activate the various control functions available within each view. The View Options in Overview, Inputs, and Inserts Views are identical; the View Options change when Sends View is active.

View Option functions are performed using latched modifiers. See the [Modifiers Overview](#) for details on how to operate the View Option controls. See [View Options](#) for descriptions of the individual option functions.

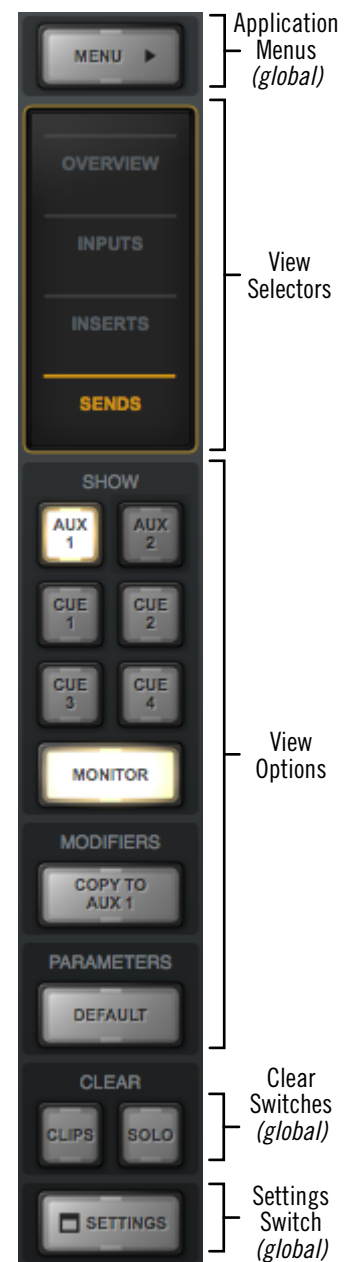

The View Column as it appears in SENDS View

Global View Column Controls

Several controls appear in all View Columns. These controls (detailed below) have identical functionality in all Views.

Menu Switch

The MENU switch is located at the top of the View Column. Clicking the switch reveals the [Application Menu](#), where various Console functions can be accessed.

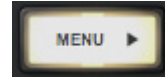

Default Switch

When [Option Latch](#) is active with the parameters DEFAULT switch, clicking any control returns the parameter to its default value.

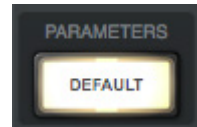

Note: The DEFAULT function is primarily for knob and fader values. It does not apply to any preamp settings, plug-in inserts, SOLO/MUTE switches, monitor levels, customized input names, and similar functions.

Clear Switches

The CLEAR switches are located near the bottom of all View columns.

Clear Clips

This switch clears all clip indicators and peak hold indicators on all meters.

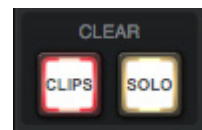

Tip: Clip and peak hold indicators can be individually cleared by clicking any individual meter.

Clear Solo

Whenever Solo is engaged on any channel input, the Clear Solo switch flashes yellow. Clicking the Clear Solo switch deactivates the Solo function of any/all channel inputs.

Tip: Click Clear Solo again to return all channels to their previous Solo states.

Settings Switch

The SETTINGS switch is located at the bottom of all View columns. It opens the Console Settings window, where many global functions are defined. For complete details, see [“Chapter 6: Console Settings” beginning on page 115](#).

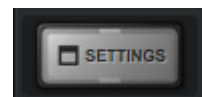

Modifiers Overview

The [View Column Options](#) in each View Column enable various operations to be performed on the items within the View.

View Option operations are performed by selecting an option to latch the function, executing the operation(s) using Modifiers, then exiting the latched function.

Option Latch

When a View Option switch is clicked, the switch flashes yellow, indicating that the function is latched and ready to be executed using the Modifiers.

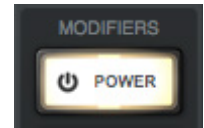

Power option latched

Option Unlatch

The latched option is unlatched (the switch stops flashing) when:

- Any same or different option switch is clicked
- A different View is selected
- No operations are executed during the Modifiers Timeout period

Modifiers Timeout

When an option is latched, it is automatically unlatched (times out) after the Modifiers Timeout period to prevent inadvertent modifications.

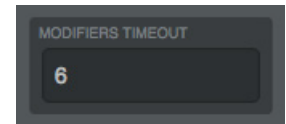

Timeout preference

The Modifiers Timeout is a preference set in the Display panel within the Console Settings window. The default Modifiers Timeout period is six seconds/flashes.

Modifiers

Modifiers are icons superimposed on various elements when a View Option is latched. Modifiers are used to execute the operations. The specific modifiers that appear, and where they are located, depend upon the specific option that is latched.

Inserts modifiers are superimposed on insert slots for individual inserts, and the input channel names for plug-in channel strips.

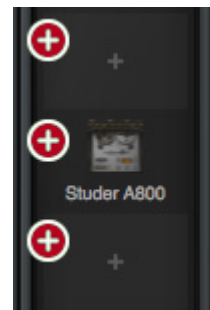

Paste Modifiers

Modifier Swipe Shortcuts

View Options can be executed extremely rapidly across many channels and/or inserts in the Current Bank using the modifiers swipe shortcuts. When a View Option is latched, click+hold the mouse, then drag vertically and/or horizontally across inserts and/or channel input names to perform the function on all locations that are swiped.

Tip: *Modifier swipe shortcuts are the fastest way to perform the same function on multiple inserts.*

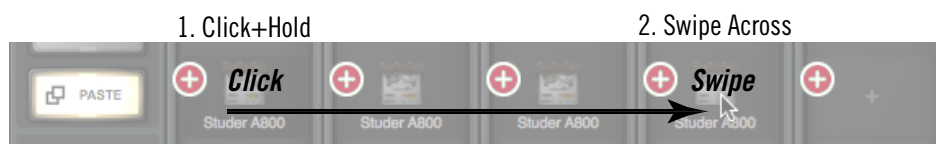

Swipe to rapidly perform the latched function on many inserts

View Options

The individual [View Column Options](#) are detailed in this section. See the [Modifiers Overview](#) for details about how to operate the Modifier controls.

Overview, Inputs, & Inserts View Options

The View Options for the Overview, Inputs, and Inserts Views are identical. Each option is described below.

Overview Note: *In the Overview View Column, the Power, Remove, and Copy modifiers may not be visible if the Console window size is vertically condensed. To bring all Overview modifiers into view, increase the vertical window size if possible, or select a different View.*

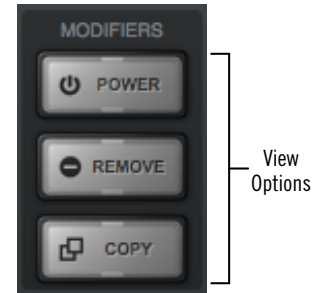

Overview, Inputs, & Inserts View modifier switches

Power Modifier

This option toggles an individual plug-in's power state within a single insert. When disabled, the plug-in no longer uses UAD DSP resources.

Click the POWER modifier switch to latch the option, then toggle any plug-in's power state by clicking its modifier, or swipe across multiple modifiers.

Note: *This option performs the same function as the [Plug-In Power](#) switch in the header within the plug-in editor window.*

When POWER is latched, disabled plug-ins are indicated by a gray modifier icon, and active plug-ins have a green modifier icon.

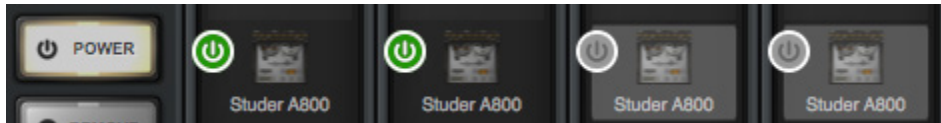

The POWER modifier when latched. Plug-ins are shown powered (left) and disabled (right).

Because this function unloads and loads the plug-in from the DSP, audio artifacts can occur if the power state is changed while audio is being processed by the plug-in.

Tip: *To disable individual plug-in processing without audio artifacts, use the power control within the plug-in interface instead, which keeps the plug-in loaded on the DSP.*

Remove Modifier

This option deletes the plug-in from the insert slot. When the REMOVE switch is latched, click any insert's modifier to delete the plug-in, or swipe across multiple modifiers.

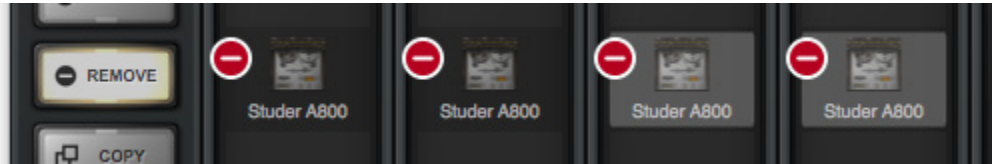

The REMOVE modifier when latched. Plug-ins are removed by clicking/swiping its modifier.

Note: Because this function unloads the plug-in from the DSP, audio artifacts can occur if a plug-in is removed while audio is being processed by the plug-in.

Copy/Paste Modifier

This option is used to duplicate individual plug-ins or channel strips, and their current settings, from one insert(s) to any other insert(s).

Copy/Paste is a two step process. First the insert or channel strip is copied with the COPY modifier, then the copied data is pasted to the destination insert or channel.

Copy Individual Plug-In

When COPY is latched, click any insert modifier to copy the insert's plug-in.

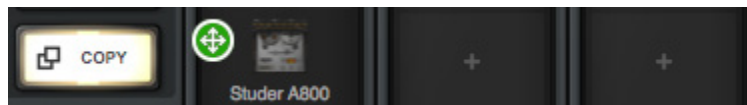

The insert COPY modifier when latched

Copy Channel Strip

When Copy is latched, click any input name modifier (at the bottom of the input strips) to copy all plug-ins in the channel inserts.

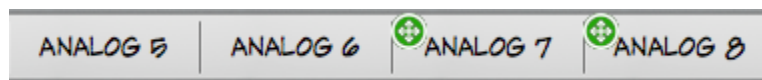

The channel strip COPY modifier when latched

Paste Modifier

After any insert is copied, the COPY switch changes to PASTE. The copied data can be pasted to multiple destinations while the paste option remains latched.

Paste Individual Plug-In

After an insert is copied, click or swipe across one or more destinations while the paste switch is latched.

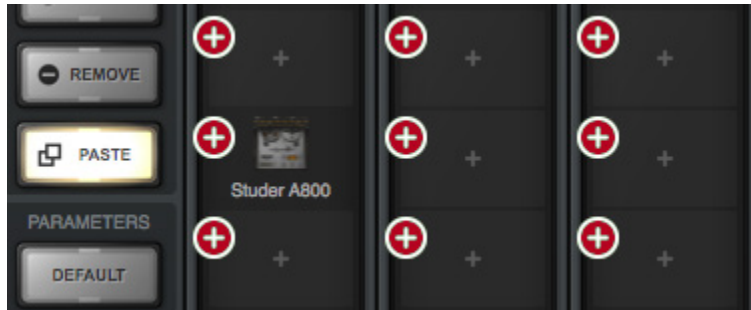

The PASTE modifiers appear on all inserts after copying an insert

Paste Channel Strip

After a channel strip is copied, click or swipe across any input name modifier to paste the copied channel strip plug-ins into the channel while the paste switch is latched.



The PASTE modifier appears on input names after copying a channel strip

Important: UAD Powered Plug-Ins within Console use DSP differently than when used within a DAW. To maintain the lowest possible input latency, UAD plug-ins used on a single Console channel strip must run on a single SHARC processor. Therefore, it is possible to get a “DSP load limit exceeded” message on a channel even if the UAD gauges may indicate there is enough DSP available.

Sends View Options

All View Options within Sends View are described below. See the [Sends Overview](#) for related information.

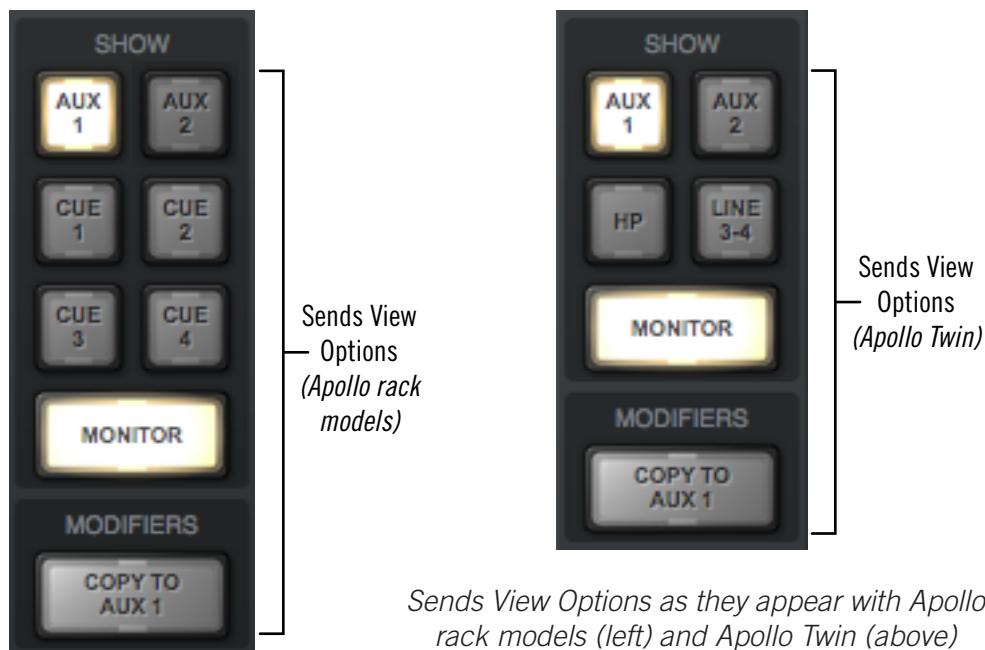

Available Sends

Two SHOW AUX switches are always visible. The SHOW CUE switches that are visible depend upon the Apollo hardware model:

Apollo Rack Models – Between two and four SHOW CUE switches are visible. This number is determined by the CUE BUS COUNT preference in Hardware panel within the Console Settings window.

Apollo Twin – The two SHOW switches are labeled HP (headphone) and LINE 3-4 (line outputs 3 and 4) to reflect the available hardware outputs on this device.

Show Sends

In Sends View, all mix controls for a single send mix bus, and/or the monitor mix bus, are displayed for all Console inputs simultaneously (see screenshots below).

Note: One send mix can be displayed at a time (the *SHOW SEND* switches are mutually exclusive).

The displayed mixes are determined by the state of the send and monitor *SHOW* switches in the Sends View column. The mix is visible when its switch is engaged (lit).

- If the *SHOW MONITOR* switch is engaged, the send's mix controls are displayed above the monitor mix controls (left screenshot).
- If the *SHOW MONITOR* switch is disengaged, only the send's mix controls are visible, offering maximum send fader resolution (center screenshot).
- If the *SHOW MONITOR* switch is engaged and all *SHOW SEND* switches are disengaged, only monitor mix controls are visible, offering maximum monitor fader resolution (right screenshot).

Tip: Sends View offers long-throw faders and meters for finer control resolution. To increase the control resolution of the mix faders in Sends View, increase the vertical size of the Console window.



*Example screenshots of interaction between the send and monitor *SHOW* switches. By showing only one type of fader (Send or Monitor), the faders are taller, offering finer control resolution.*

Show All Sends Option

All sends can be viewed simultaneously by holding the Option key (on computer keyboard) while clicking any SHOW switch in Sends View.



All sends are visible when a SHOW switch is option-clicked

Sends COPY TO Modifier

This switch instantly copies the current monitor mix to the send mix that is currently selected with the [Available Sends](#) switches.

Tip: The COPY TO function is typically used when a cue mix that is similar to the monitor mix is needed, but with minor adjustments (e.g., creating a “more me” cue mix).



COPY TO modifier

The text label within the COPY TO switch changes to the send mix that is currently selected with the [Available Sends](#) switches, indicating the destination of the pasted monitor mix.

Caution: Use the COPY TO function carefully. Depending on the states of the monitor mix and the destination send mix, cue output routings, and the volume setting of monitoring systems (e.g., headphones) attached the cue outputs, this function could cause an extreme increase in volume at the destination outputs.

COPY TO Menu

Right-clicking (or control-clicking) the main (silver) monitor faders presents the COPY TO menu. Selecting a destination performs the same function as the COPY TO modifier described above.



COPY TO menu

Info Bar

The Info Bar is always visible at the bottom of the Console window. It displays and provides access to several important functions.

The Tempo controls are only available in the Info Bar. The Sample Rate and Clock Source controls are also available in the Console Settings window. The UAD Resource Gauges have no controls; they are visual indicators only.

Refer to the diagram below for descriptions in this section.

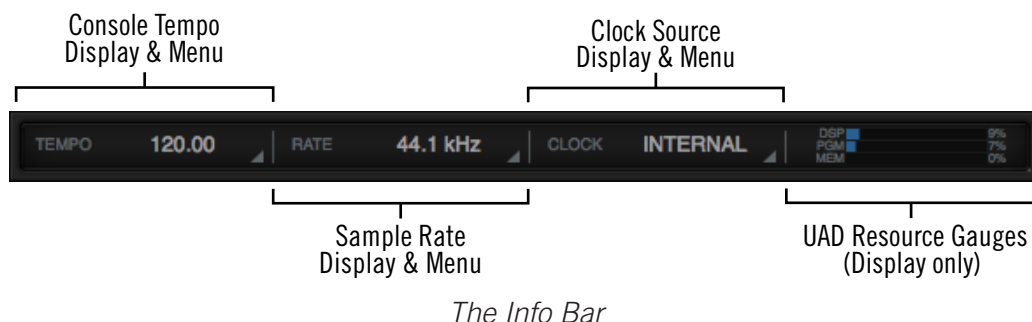

Offline Hardware Display

If the Apollo hardware unit(s) is not properly connected, the sample rate and clock source will display OFFLINE as shown below.

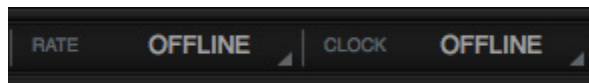

Sample Rate and Clock when Apollo is offline

Tempo Display

This area displays the Console tempo in beats per minute (BPM). Clicking the tempo display opens the Tempo popover window, where a new tempo can be typed or tapped.

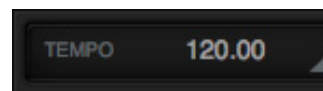

About Console Tempo

Console Tempo is used for time-based UAD plug-ins (such as delays and modulations) within Console that are set to use Tempo Sync. Console Tempo can be modified by typing a text value, tapping a tempo, or via MIDI.

Note: Console does not receive tempo information from the DAW.

The tempo value is saved within Console session files, and also within DAW files when the Console Recall plug-in is used within the DAW.

For details about how to use the Tempo Sync feature with UAD plug-ins, see the UAD System Manual.

Tempo Window

To display the Tempo window, click anywhere in the Tempo Display within the Info Bar.

The available tempo range is from 1.00 BPM to 999.00 BPM. The default tempo of a new session is 120 BPM.

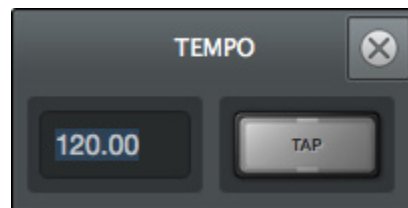

Adjusting Tempo

Text Entry

1. Open the Tempo window by clicking the Tempo Display in the Info Bar
2. Click the tempo text field, then type a numeric tempo value
3. Press Return or Enter, or click the close button with the mouse.

Tip: To leave the tempo unchanged after entering an (unwanted) value in the Tempo window, press the ESC key or close the window with the mouse.

Tap Tempo

1. Open the Tempo window by clicking the Tempo Display in the Info Bar
2. With the mouse, click the TAP button at least four times to establish the tempo
3. Press Return or Enter, or click the close button with the mouse.

Changing tempo via MIDI

Tap tempo can be used to set a new tempo from incoming MIDI that is received via the Mac OS X operating system. This method requires any external MIDI hardware and/or MIDI software that is recognized by Audio MIDI Setup (Mac OS X's MIDI routing utility application, located in /Applications/Utilities).

About external MIDI tap tempo control

- Audio MIDI Setup must be properly configured. After proper configuration, Audio MIDI Setup does not need to remain open.
- MIDI note values or MIDI controller values can be used as the data source.
- Console cannot synchronize the tempo to incoming MIDI beat clock.

MIDI configuration/setup

1. Verify the MIDI output device and/or MIDI software is configured properly and active in Audio MIDI Setup.
2. In the MIDI panel within the Console Settings window, set the values for DEVICE, TAP TEMPO CHANNEL, and TAP TEMPO EVENT to match the transmitted MIDI data.
3. Transmit the MIDI note or controller (as specified in the previous step) at least four times to establish the tempo. The Tempo Display is RED during this period.
4. After a new tempo value is established, the new tempo is used and the Tempo Display changes back to BLACK. Simply retransmit the MIDI data to apply further tempo updates.

Sample Rate Display

This area displays the current sample rate used for Apollo's A/D-D/A conversion and UAD Powered Plug-Ins processing. When using UAD Powered Plug-Ins, higher sample rates require more UAD DSP resources.

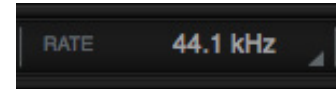

Important: When the Clock Source parameter is set to use any external clock source, the sample rate must be manually set to match the sample rate of the external clock.

Sample Rate Menu

Clicking the Sample Rate Display presents the Sample Rate Menu, where the current sample rate can be changed.

Important: When a DAW is used with Apollo, the sample rate is typically changed within the DAW settings. If the sample rate is changed to a different value within Console when a DAW is active, digital artifacts could occur due to a sample rate mismatch.

Apollo Twin Note: If the current digital input setting is S/PDIF and the sample rate is changed to a rate higher than 96 kHz, the clock source is changed to Internal and the S/PDIF inputs are no longer unavailable.

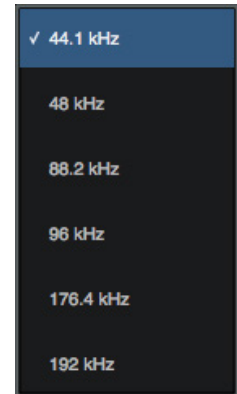

Clock Display

The Clock Display has three functions: It shows the currently selected clock source, facilitates selection of a different clock source, and indicates when the selected clock source signal is not detected.

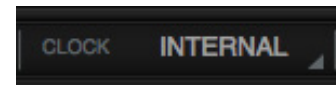

Clock Source Menu

Apollo can synchronize to its internal clock or an external clock (word clock, ADAT, or S/PDIF). To select a clock source, click anywhere in the clock display area to view the Clock Source Menu, then select a clock source from the menu.

Tip: The clock source can also be specified in the Hardware panel within the Console Settings window.

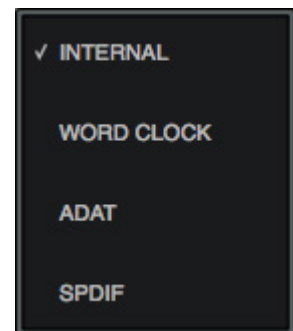

No External Clock

If the Clock Source setting is *not* set to Internal and the external clock signal cannot be detected and/or resolved, then the text in the Clock Display display flashes RED (as shown at right) until a valid clock is detected and/or an alternate clock source is selected. If this occurs, verify connections and external device settings.

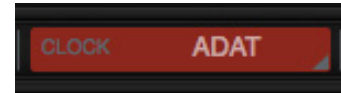

Important: Only one device in a digital audio system can be the master clock source. The Apollo clock setting, and the sample rate, must match the master device settings or audio artifacts could occur.

UAD Resource Display

UAD plug-in loads are shown in the Resource Display at the far right of the Info Bar. These three gauges (DSP, PGM, and MEM) provide important visual feedback in realtime, by helping to determine which plug-ins to load if available UAD resources are limited.

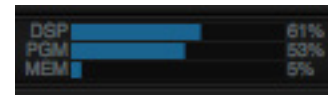

The UAD resources are displayed as blue bar graphs and as percentages. These gauges have no controls; they are visual indicators only.

Tip: The Resource Display mirrors the meters within the UAD Meter & Control Panel application.

Averaged Loads

The load for each gauge represents the average for all UAD devices in use. For example, if one Apollo QUAD unit is installed, the UAD DSP load is an average of the four SHARC DSP processors in the unit. If two QUAD units are installed, then the eight processors are averaged, and so on.

Individual Loads

Individual DSP loads within a single unit, and the loads of individual devices in a multi-device setup, can be viewed in the System Information panel within the included UAD Meter & Control Panel application.

UAD Plug-In Loads

The amount of UAD resources used by UAD plug-ins vary with each individual plug-in; more complex algorithms require more resources.

Instance Chart

The amount of DSP used by each individual UAD plug-in is available in the UAD instance count chart. The chart can help determine which to plug-ins to assign with available resources. The chart is published online at:

- www.uaudio.com/support/uad/compatibility/instance-chart.html

Static Loads

Apollo uses UAD DSP and memory for its internal DSP mixer, therefore the meters will indicate loads (when the hardware is connected) even if UAD plug-ins are not inserted.

DSP

The DSP gauge indicates the amount of digital signal processing resources that are being used by all UAD devices in the system.

DSP is the primary hardware resource that powers the UAD Powered Plug-Ins algorithms. When UAD plug-ins are disabled, DSP requirements are decreased.

***Note:** When UAD plug-ins are disabled, DSP requirements are decreased EXCEPT when the plug-in is disabled using the Power control within the plug-in interface.*

Program

The Program (PGM) gauge indicates how much UAD program memory (PGM) is in use. Program memory is an on-chip memory that is specific to the UAD-2 DSP processor(s) and is used for certain UAD plug-in resources.

Each unique UAD plug-in uses a bit of program memory. If many different UAD plug-ins are loaded simultaneously, it is possible for this resource to run out before a DSP overload occurs. This point is considered and factored in by the automatic UAD load balancing routines.

Memory

The Memory (MEM) gauge indicates the percentage of UAD RAM that is currently in use. It indicates the total available UAD memory available, regardless of the number of DSP processors that are installed.

Memory is used for echo, delay lines, reverb, and similar spatial processing. When UAD plug-ins are disabled but not unloaded, memory requirements are not decreased. In this case, the memory remains loaded so that reverb tails and delay lines are not cut off when the plug-in is disabled.

Channel Input Controls

Note: For related information, see the [Channel Strips Overview](#).

Preamp Controls

Note: The preamp controls do not apply to Apollo 16, which does not feature mic preamps.

Console's preamp controls correspond to the equivalent preamp controls on the Apollo front panel. Adjusting Apollo's front panel will update Console (and vice versa); see [Interactions Between Console and Apollo](#) for details.

Unison Controls

 Some preamp hardware controls (Gain, Low Cut, 48V, Pad, Polarity) are Unison parameters that interact with Unison plug-ins placed in the Unison insert slot.

Unison preamp controls in this section are indicated by the Unison icon in the above paragraph. For complete Unison details, see [“Chapter 8: Unison” beginning on page 144](#).

Refer to the illustrations below for element descriptions in this section.

vv

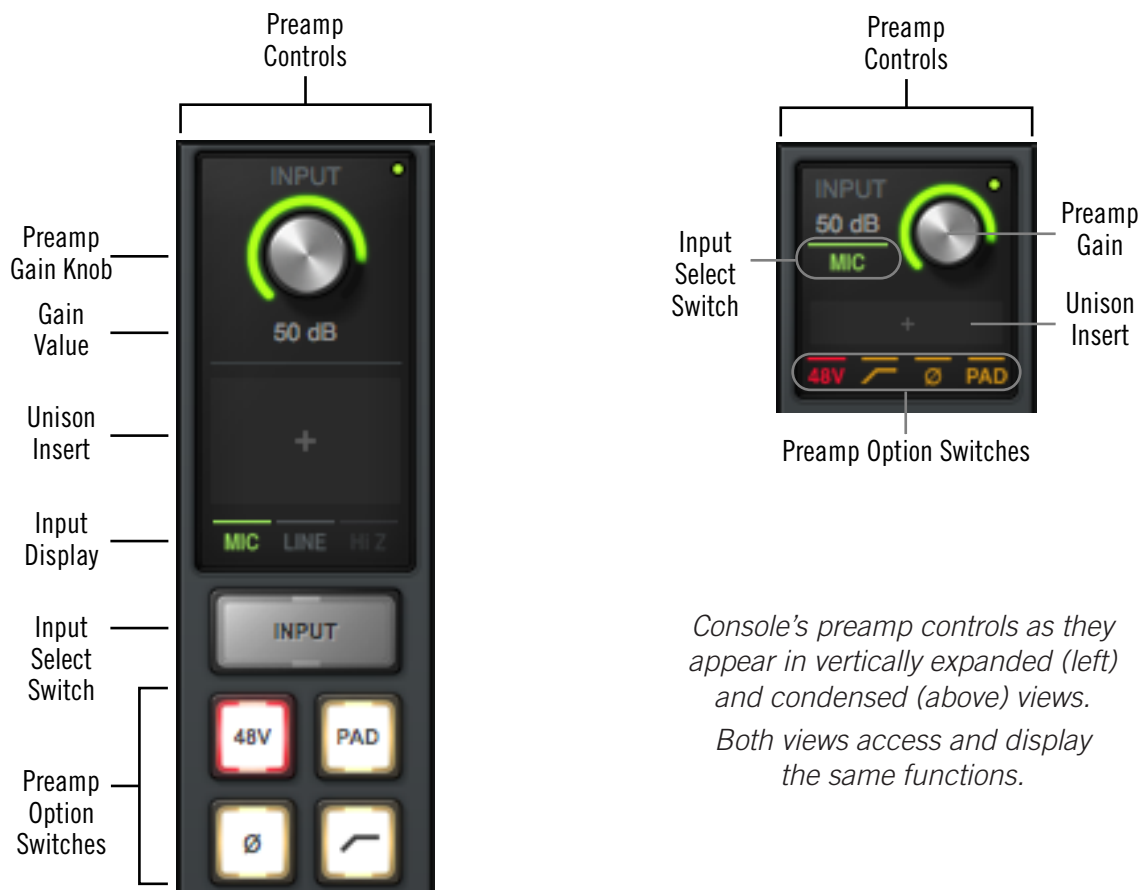

Preamp Gain

 The channel's preamp gain is adjusted with this knob. The input to be adjusted (Mic, Line, or Hi-Z) is determined by the state of the channel's Mic/Line switch or the Hi-Z input (if connected).

Rotating the knob clockwise increases the preamp gain for the channel. The available gain range for all preamp channels is 10 dB to 65 dB for the Mic, Line, and Hi-Z inputs.



Gain Value

The specific amount of preamp gain in decibels is displayed in gray text near the gain control. The relative amount of preamp gain is indicated by the green “LED ring” surrounding the gain control. The LED ring is a different color when Unison is active in the channel.

Line Input Gain Bypass (Apollo 8, Apollo 8p)

When a preamp channel's line input is selected and its Line Input Gain is bypassed, the Gain Value field displays **BYP**, its gain cannot be adjusted, and the Unison plug-in (if inserted) is disabled. For related details, see [Line Input Gain \(Apollo 8, Apollo 8p\)](#).



Line Input Gain bypassed

Front Panel Channel Selection Indicator Dot

Apollo's channel selection can be changed using the front panel hardware. The small colored dot that appears next to the gain control (as shown at right, outlined in red) indicates the preamp channel that is currently selected with Apollo's front panel.



Note: The indicator dot in Console changes channels when the channel selection is changed with Apollo's front panel.

Unison Insert

 Unison is an exclusive analog/digital integration technology that's built into every Apollo microphone preamplifier. The preamp controls in Console interact extensively with Unison plug-in parameters.

To add a Unison plug-in to the preamp channel, click the unique Unison insert slot located below the Gain control (as shown at right, outlined in red). For complete Unison details, see [“Chapter 8: Unison” beginning on page 144](#).



Input Select

This switch switches between the mic and line inputs on Apollo's rear panel. Click the Input Select switch or Input Select display to change the input type. The currently selected input type is highlighted. To switch the input type in condensed views, click the currently displayed input type (as shown at right, outlined in red).



Note: *Input Select has no effect if the channel's Hi-Z input is connected, because preamp channels are automatically switched to the Hi-Z input when a ¼" mono (tip-sleeve only) cable is connected to Apollo's front panel Hi-Z input jack.*

Low Cut Filter

 When enabled, the channel's input signal passes through a low cut (high pass) filter. This 2nd-order coincident-pole filter has a cutoff frequency of 75 Hz with a slope of 12 dB per octave by default (the filter can change when Unison is active in the channel).



The Low Cut filter effects the Mic, Line, and Hi-Z inputs. Low Cut is typically used to eliminate rumble and other unwanted low frequencies from the input signal.

48V

 When enabled, the 48V switch is red and 48 volts of phantom power is supplied to the Apollo channel's rear panel Mic input. Most modern condenser microphones require 48V phantom power to operate. This option can only be activated when the Mic/Line switch is set to Mic.



Caution: *Activate 48V only with compatible equipment such as phantom powered microphones. Incompatible equipment may be damaged by the applied voltage.*

Depending on the current configuration of the Apollo and Console, there may be a delay when changing the 48V state to minimize the clicks/pops that are inherent when engaging phantom power. The +48V LED on Apollo's front panel will flash during any delay.

Pad

 When enabled, the PAD switch is yellow and the channel's microphone input signal level is attenuated by 20 dB. Pad does not effect the Line or Hi-Z inputs.

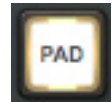

Pad is used to reduce signal levels when overload distortion is present at low preamp gain levels, such as when particularly sensitive microphones are used on loud instruments, and/or if the A/D converter is clipping.

Polarity

 When enabled, the polarity (aka "phase") switch is yellow and the input channel's signal is inverted. Polarity affects the Mic, Line, and Hi-Z inputs.

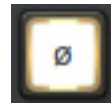

Polarity inversion can help reduce phase cancellations when more than one microphone is used to record a single source.

Reference Level (Apollo, Apollo 8, Apollo 16)

The signal reference level for analog line inputs without preamps can be switched between -10 dBV and +4 dBu. Click the display to toggle the setting.

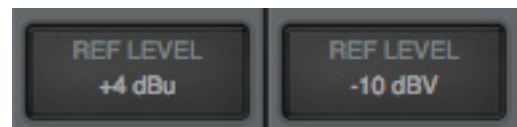

The setting controls an attenuation pad for the input channel. When set to +4 dBu, the pad is engaged and the channel can accept a higher signal level before the A/D converter clips. Select -10 dBV when lower input signal levels are used.

Tip: To adjust signal incoming levels for Apollo's analog inputs that don't have preamps, use the output level controls of the devices that are connected to those inputs.

Tip: Additional gain can be added to input signals by inserting UAD plug-ins and adjusting the gain structure within the plug-ins.

The availability and behavior of the reference level control depends on the hardware model, as described below.

Apollo & Apollo 8 – The reference level for analog input channels 5 & 6 and 7 & 8 are linked in Apollo's hardware. Therefore, the reference level in Console can only be switched according to these stereo pairs.

Apollo 16 – The reference level for all analog input channels 1 – 16 can be individually switched.

Sample Rate Convert

Realtime sample rate conversion ("SR CONVERT") is available on S/PDIF and AES/EBU inputs. This feature eliminates audio artifacts (clicks, distortion, etc) that can occur when the sample rate of external digital devices connected to the S/PDIF or AES/EBU inputs do not match Apollo's internal sample rate.

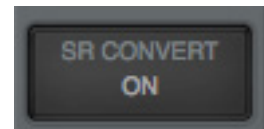

To enable realtime sample rate conversion on Apollo's S/PDIF or AES/EBU inputs, click the SR Convert switch in Console's associated channel strip. Click again to disable the feature.

Sample Rate Conversion notes:

- SR Convert is available on S/PDIF or AES/EBU inputs only
- SR Convert applies to both L/R inputs (they can't be individually enabled)
- SR Convert functions on both L/R inputs whether or not they are stereo linked
- SR Convert is unavailable when Apollo's clock source is set to S/PDIF or AES/EBU
- SR Convert is unavailable on digital outputs

UAD Plug-In Inserts

All Console plug-in insert slots operate the same way. For complete details on all insert functionality and operations, see ["Chapter 5: UAD Plug-In Inserts"](#) beginning on page 99.



UAD plug-in inserts

Sends Popover

Note: See “Sends Overview” beginning on page 35 for related information.

The Sends popover window is where all available sends for an individual channel can be adjusted. To access the Sends window, click the Sends display when Overview is active.

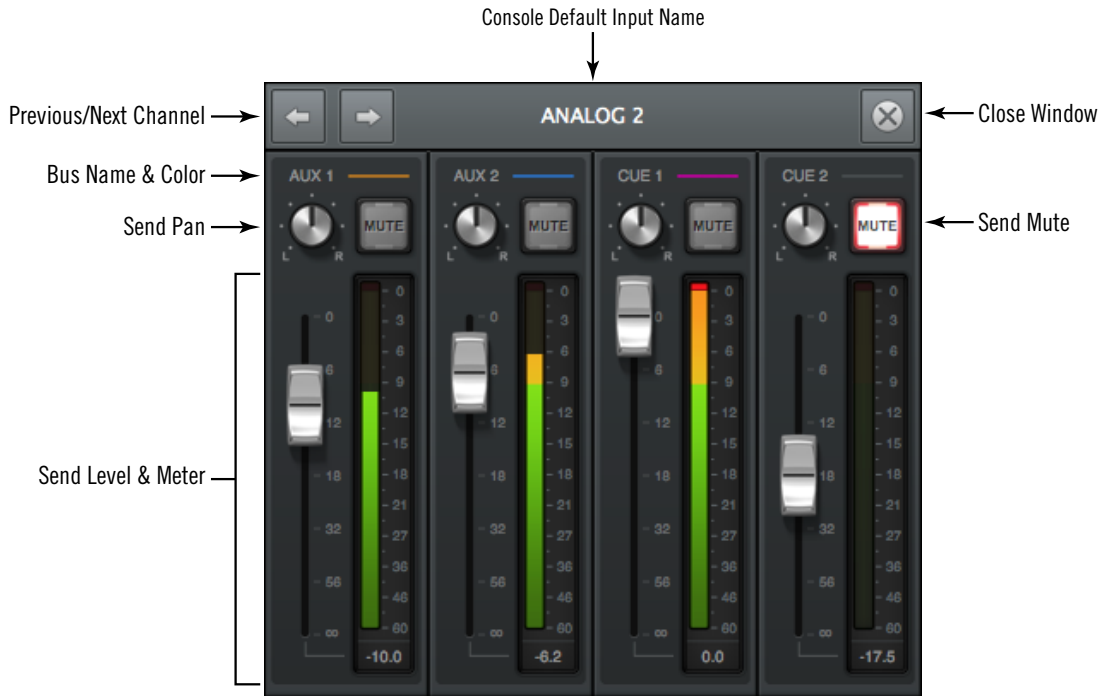

The Sends popover

Sends Popover Window Descriptions

Input Name – The name of the Apollo input is displayed as the window’s title. If the input name is customized in Console, the customer name is displayed here.

Previous/Next Channel – These buttons switch the window to display the sends of adjacent channels. The “Command+Left/Right Arrow” keyboard shortcut can also be used to navigate channels.

Tip: To prevent the window from moving when these buttons are used, drag the Sends window to any location other than its default position.

Bus Name & Color – The bus name and its color are displayed above each send.

Send Pan – Adjusts the input’s position in the stereo field of the send bus. The pan knobs are not displayed when the input is in stereo linked mode, which forces the stereo channels to automatically pan hard left/right.

Send Mute – The Mute button can be used to disable/re-enable the bus send. When the send is active, the button is lit.

Send Level – This fader adjusts the input channel’s signal level sent to the bus.

Send Meter – The post-fader signal level of the Send is displayed here.

Flex Routing

By default, Apollo's input channels are routed to the monitor outputs only. However, Apollo's inputs can be optionally routed to any available Apollo hardware output. A maximum of eight channel output route assignments are available. This feature is available with Apollo rack models only (Flex Routing is unavailable with Apollo Twin).

Important: *If an output is in use by Flex Routing, it is no longer available to be assigned as an output within the DAW. The Flex channel output(s) route overrides the DAW output channels assigned to the same hardware output(s).*

Multiple input signals cannot be merged to the same output(s) with Flex Routing because this feature is not a mix bus. However, the cue mix buses can be used for this purpose.

Note: *Flex Routing is unavailable at sample rates of 176.4 kHz and 192 kHz.*

Output Route Display

The Output Route display is located above the each channel's main input mix controls, as shown at right. The active output assignment is displayed here. Clicking the display opens the Output Route window.

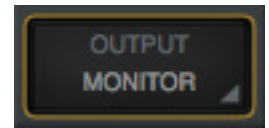

Output Route Display

Output Route Popover

The Output Route popover window is where the hardware output assignment for the input channel can be changed.

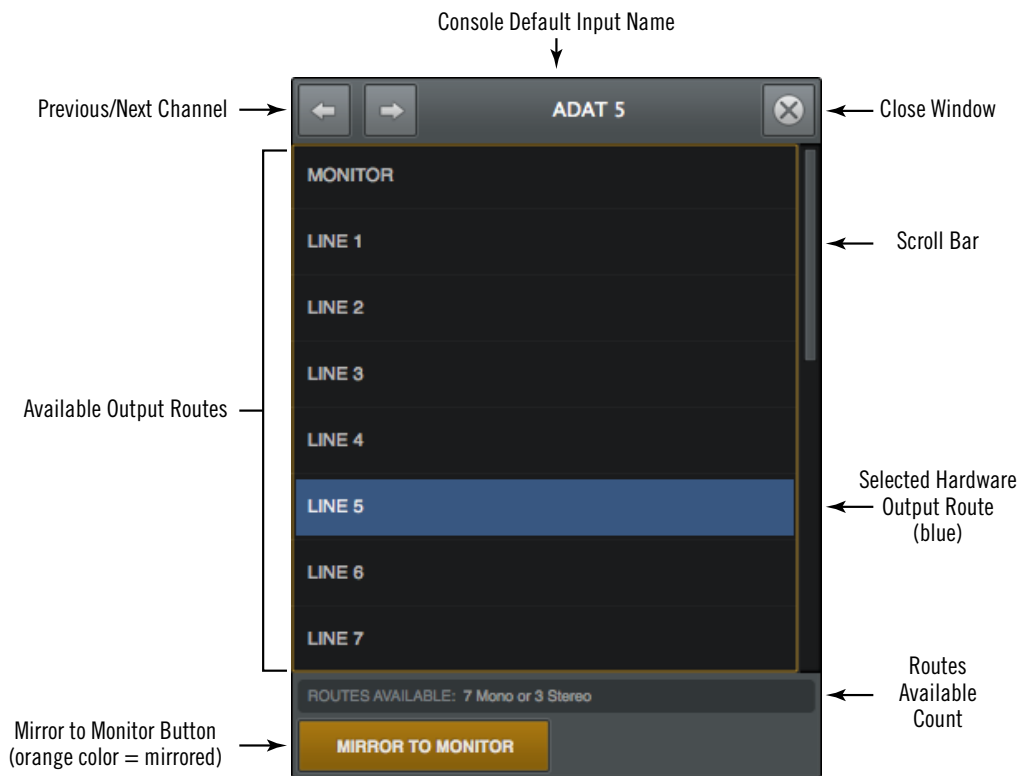

The Output Route popover

To change the output route:

1. Click anywhere in the Output Route display to reveal the Output Route window.
2. Select an output (or output pair, for stereo linked channels) in the window.



Channel is routed to line output 5

Note: *If an output does not appear in the window, the output is already in use by another input channel, cue output, or ALT output.*

Routes Available Count

The number of currently available mono and stereo channel output routes is displayed in gray text at the bottom of the menu. The number is decremented with each assignment. Up to eight outputs can be assigned with Flex Routing.

Mirror to Monitor

When a channel is routed to an output other than the monitor outputs, the channel is simultaneously routed to the monitor outputs (mirrored) by default. Mirroring to the monitor outputs can be disabled so the channel is routed only to the output selected in the Output Route menu.

To toggle monitor mirroring, click the “Mirror to Monitor” button in Output Route menu. Monitor mirroring is active when the button is orange colored. Mirroring is off when the button is gray.

Monitor Mix Controls

The monitor mix controls within the input channel strips are for adjusting the signals at Apollo's monitor outputs.

Refer to the illustration at right for descriptions in this section

Input Pan

This control adjusts the input's position in the stereo panorama of the monitor mix bus.

Stereo Input Pan

When the input is stereo linked, two pan knobs appear for the channel enabling independent panning for both the left and right channels. When stereo link is activated, the default position of the dual pan knobs are hard left/right.



Pan with channels unlinked (left) and linked (right)

Input Solo

Solo mutes all input signals, except for any inputs in solo mode. Solo is used to hear individual channels in the monitor mix without having to modify other channels.

Note: *Input solo does not effect the channel's cue sends, which are pre-fader.*

Click the switch to toggle the solo state. The channel is in solo mode when its solo switch is highlighted in yellow. Note that activating mute has no effect if the channel is in solo mode.

Tip: *Option-click the solo button to toggle solo on all input channels.*

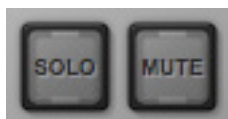

Inactive solo and mute switches

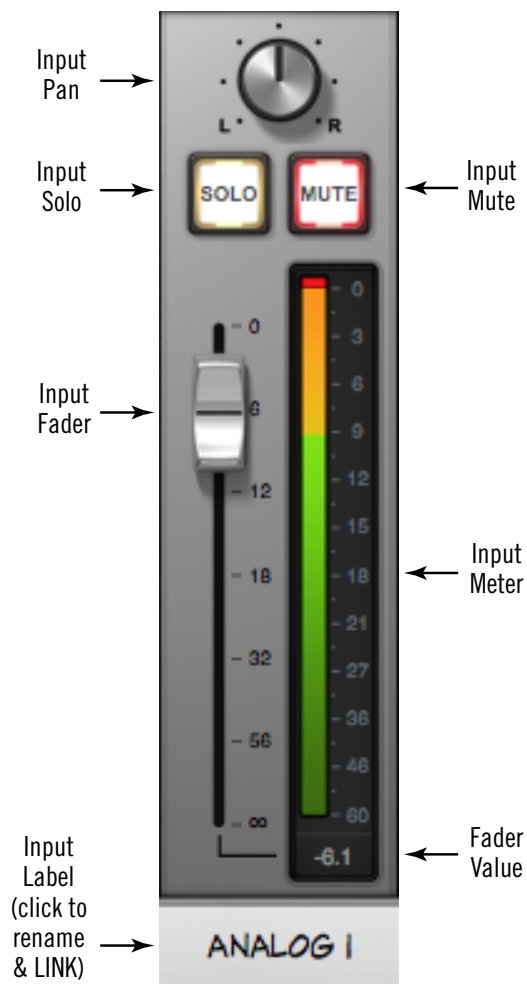

The Monitor Mix Controls

Input Mute

Mute prevents the input channel's signal from being routed to the monitor mix bus (and aux buses that are in POST mode), but not the cue mix buses.

Click the button to toggle the mute state. The channel is muted when its mute switch is highlighted in red.

Tip: Option-click the mute button to toggle mute on all input channels.

The input meter is still active when the channel is muted for a visual reference that there is still a signal coming into the channel even though it isn't heard in the monitor mix.

Note: Input mute does not affect the channel's cue sends, which are pre-fader. All cue sends have their own mute switch.

If Solo is activated on the same channel when muted, the mute state is overridden and the channel is heard in the monitor mix.

Input Fader

This is the channel's main signal level control for the monitor mix. Changes to this control are reflected in the channel's level meter.

The input fader adjusts the channel's level in the monitor mix bus (the monitor outputs) and the aux mix buses (when set to POST mode), but not the cue mix buses.

Fader Scale

The numerical labels next to the fader represent the amount of attenuation applied by the fader. A value of "0" represents 0 db of attenuation.

Fader Value

The input fader's current setting is displayed beneath the input meter.



Copy Mix

All channel fader and pan values for all inputs (the entire monitor mix) can be copied simultaneously to any send mix bus.

To copy the monitor mix to a send mix bus, right-click (or Ctrl-click) any channel fader to display the copy mix menu, then select a destination bus for the mix.

Tip: This is the same function as the [Sends COPY TO Modifier](#) within the Sends View column.



The Copy Mix menu

Input Meter

The input meter displays the signal level of the channel after UAD plug-in processing in the inserts. Depending on the state of the METERING option in the Display panel within the Console Settings window, (either pre-fader or post-fader), this meter will display the level going into the monitor mix bus (post-fader/post-inserts), or the level at the channel's hardware input (pre-fader/post inserts).

***Tip:** When recording into a DAW, it's typically best to keep metering set to pre-fader so they accurately represent the signal level at the DAW inputs.*



Pre/Post metering preference

Input Level Scale

The numerical labels represent digital signal levels. "0" represents 0 dBFS (digital full scale, the maximum level before undesirable A/D clipping). If the level at the Apollo input exceeds 0 dBFS, the meter's clip indicator illuminates. If clipping occurs, reduce the preamp gain, the output level of the device feeding the input, or the output gain(s) of UAD plug-in processing in the inserts.

Peak Hold

The input meters also have a peak hold feature, which "holds" signal peak values for a specified period of time. The clip and peak hold times can be adjusted in the Display panel within the Console Settings window.

Rename/Link Popover

The Rename/Link popover window is used for customizing input labels and stereo linking adjacent channels.

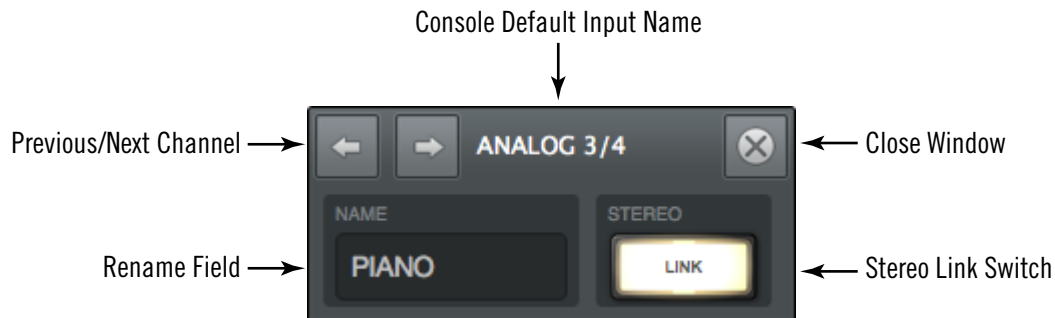

The Rename/Link popover

Input Label

By default, the name of the Apollo hardware input is displayed beneath the channel's fader and meter. The input labels can be customized for convenient input identification.

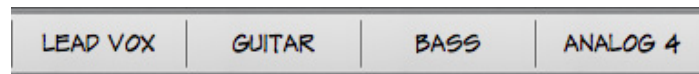

Input labels showing several customized input names

Input Label Menu

The Input Label Menu contains the same functions as the Rename/Link window, and also the ability to hide the input from view. To display the Input Label Menu, right-click any Input Label.

Tip: To re-show an input hidden via this menu, use the [Show/Hide Inputs](#) function.



To customize a channel input name:

1. Click an input label or choose "Rename" from the Input Label Menu. The Rename/Link popover window appears.
2. Type a custom name for the input.
3. Press Return/Enter or click the close button.

To return to the default name:

1. Click an input label or choose "Rename" from the Input Label Menu. The Rename/Link popover window appears.
2. Press the Delete key to remove the customized text from the NAME field.
3. Press Return/Enter or click the close button.

Input label Notes

- To identify the hardware input when an input name is customized, click the input label. The hardware input name appears at the top of the popover window.
- Custom input labels are a global function; they are not stored in Console session files.
- Auxiliary return labels cannot be customized.
- Custom input labels are visible within Console only.

Tip: Driver I/O labels, which are displayed within a DAW, can be customized separately in the Core Audio panel within the Console Settings window.

Show/Hide Inputs

Console can hide any input channel strip from view. This feature reduces the need for horizontal scrolling and/or simply reduces visual distractions when there is no need to see or manipulate a particular input.

How To Use Show/Hide Inputs

1. Either choose “Show/Hide Inputs” from the [View Menu](#), use the keyboard shortcut (⌘I), or right-click (control-click) the [Input Label Menu](#). Modifier icons appear on all Input Labels (see the [Modifiers Overview](#) for related details).

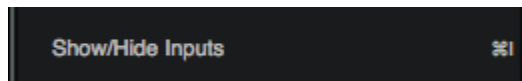

2. Click or swipe across the Input Labels. The modifier toggles between green and gray. The input will be shown when its modifier is green, and hidden when gray.



3. Click the DONE switch in the View Column. The inputs with gray modifiers are hidden. To bring hidden inputs back into view, repeat the procedure.

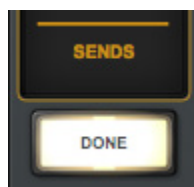

Show/Hide Input Notes:

- A minimum of one input channel must be shown.
- All input channels remain active even if they are hidden from view.
- The [Show Aux Returns](#) switch is available to show/hide the aux return strips.

Stereo Link

Adjacent channels (1+2, 3+4, etc) can be linked to create stereo input pairs. When channels are linked as a stereo pair, any control adjustments will affect both channels of the stereo signal identically.

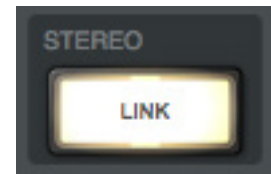

Note: Only the same type of inputs can be linked (Mic/Mic or Line/Line), and the Hi-Z inputs cannot be linked.

Activation

Stereo pairs are created by activating LINK within the [Rename/Link Popover](#). For preamp channels (Apollo and Apollo Twin), activating LINK performs the exact same function pressing the LINK button on Apollo's front panel. To stereo link all channels in Console, option-click the LINK button.

Tip: Option-click the LINK button to stereo link all channels.

When Link is activated:

- The LINK switch is lit instead of gray
- One set of controls is available for the stereo channel (except pan, as noted below)
- All current control settings of the left channel are copied to the right channel (except pan, as noted below)
- All inserted plug-ins in the left channel are converted to stereo (parameter values are retained)
- The input pan knob changes to dual pan knobs
- Pan values are forced to hard left and hard right
- The send pan knobs are hidden from the interface (pans are forced to hard left/right with stereo sends)
- The input level meter changes to a stereo meter
- The custom input names revert to default input names



Before and after engaging stereo LINK

Deactivation

A stereo pair is separated back into individual channels by clicking the LINK switch when it is active (the LINK switch is gray when deactivated). When LINK is deactivated, all current control settings and inserted plug-ins for the stereo channel are copied to both channels (except pan, which is centered for both channels).

Link Constraints

- Odd-numbered channels can only be linked to the next even-numbered channel. For example, Analog 1 can be linked to Analog 2, but Analog 2 cannot be linked to Analog 3.
- Only the same type of inputs can be linked (for example, an analog input can only be linked to an analog input).
- For preamp channels (Apollo & Apollo Twin), only the same input jacks can be linked (for example, a Mic input cannot be linked to a Line input).
- The Hi-Z inputs cannot be linked.

Aux Returns

Aux Overview

Console has two stereo aux (auxiliary) mix buses. Signals are sent to the aux buses via the aux sends in Console's channel input strips. Console's aux returns are used to control and process the signals that are received from those sends.

The controls in Console's aux return strips are similar to the channel input strips, but instead of controlling a channel input, they control the output of the aux mix bus. Both stereo aux returns have four plug-in inserts for Realtime UAD Processing.

The aux sends can be post-fader and post-mute (channel faders must be raised and un-muted to be routed to the aux bus, and the send levels will reflect channel fader changes), or pre-fader and pre-mute (channel faders and mutes do not affect the aux bus).

The aux buses in Console are designed primarily for send/return processing using UAD plug-ins. Using aux buses for effects is a great way to conserve UAD resources. For example, by using an aux for reverb processing, only one reverb plug-in is needed on the aux return instead of putting a reverb plug-in on each individual channel.

Show Aux Returns

By default, the aux returns are not visible. To show the aux returns, enable the AUX switch in the SHOW section of the monitor column.

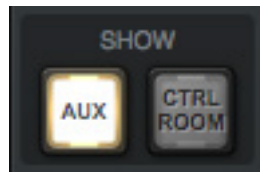

The Show Aux switch in the monitor column



Console's Aux returns

Aux Notes

- Aux 2 is unavailable at sample rates of 176.4 kHz and 192 kHz.
- The outputs of the aux buses have 32 samples of additional latency compared to the monitor outputs. This is necessary to maintain the lowest possible latency for the dry signals.

Aux Return Strips

Both of Console's aux return strips are identical. Most of the controls have identical functionality as their equivalent control in the channel input strips.

Refer to the diagram at right for descriptions in this section.

Aux Inserts

The aux inserts are operated using the same methods as the insert controls in the channel input strips. See [“Chapter 5: UAD Plug-In Inserts” beginning on page 99](#) for complete descriptions of the aux insert controls.

Important: UAD plug-in processing in the auxiliary inserts are always routed to the DAW, regardless of the Insert Effects setting (aux insert processing is always recorded).

Aux Cue Sends

The aux returns can be routed to any available cue mix buses using the cue sends on the aux returns. There is no cue pan control on the aux returns, because the aux returns are stereo.

The aux cue sends are operated using the same methods as the send controls in the channel input strips. See [Sends Pop-over](#) for complete descriptions of the aux send controls.

Note: When a Cue Source is set to cue, aux returns must be sent to the cue mix bus via these controls for the aux to be heard in the cue mix.

Aux Pre

When the PRE switch is engaged (lit), the aux mix bus is pre-fader and pre-mute. In PRE mode, the channel faders and mutes do not affect the aux bus.

Tip: Pre-fader mode is useful for configuring a mix bus that is independent of the monitor mix controls (for example, when creating a cue mix).

Aux Post

Post-fader is the default setting for Aux 1 and Aux 2. When the POST switch is engaged (lit), the aux mix bus is post-fader and post-mute. In POST mode, the channel faders must be up and un-muted to be routed to the aux bus, and the aux send levels will reflect channel fader changes.

Tip: Post-fader mode is typically used when configuring an effect send mix so the effect sends will interact with the main channel controls.

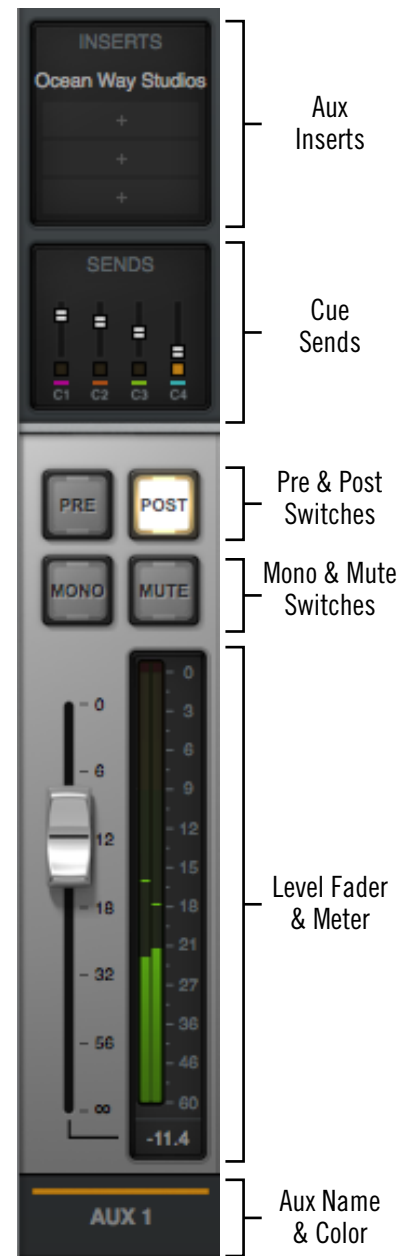

The Aux Return Strip

Aux Mono

This switch sums the left and right channels of the stereo aux mix bus output into a monophonic signal. The aux return output is stereo when the button is gray and mono when the button is lit.

Aux Mute

The aux mute switch stops the aux return's signal from being routed to the monitor mix. The aux return output is active when the button is gray and muted when the button is lit.

Note: *Aux mute does not mute the aux cue sends.*

Aux Fader

This is the master signal level control for the aux bus return to the main monitor mix. It does not affect the aux bus return's cue sends.

Aux Meter

The aux meter displays the signal level of the aux return after UAD plug-in processing in the aux inserts. Depending on the state of the METERING option in the Display panel within the Console Settings window, (either pre-fader or post-fader), this meter will display the aux bus output level routed into the monitor mix bus (post-fader/post-inserts), or the level of the aux mix bus itself (pre-fader/post inserts).

Input Level Scale

The numerical labels represent digital signal levels. "0" represents 0 dBFS (digital full scale, the maximum level before undesirable A/D clipping). If the level of the aux bus exceeds 0 dBFS, the meter's clip indicator illuminates. If clipping occurs, reduce the aux sends from the input channels and/or the output gain(s) of UAD plug-in processing in the aux inserts.

Peak Hold

The aux meters also have a peak hold feature, which "holds" signal peak values for a specified period of time. The clip and peak hold times can be adjusted in the Display panel within the Console Settings window.

Tip: *When recording into a DAW, it's typically best to keep metering set to pre-fader so they accurately represent the signal level at the DAW inputs.*

Monitor Column

The Monitor Column is always visible at the right side of the Console window. The Monitor Column contains elements related to monitor outputs, cue outputs, insert effect printing, and session file management, as shown at right.

Note: Settings in the Monitor Column are global functions. They are not saved with individual Console sessions files.

Monitor Meters

The Monitor Meters display the levels of Apollo's monitor mix bus. Levels displayed here mirror the state of the Monitor 1 – 2 LED meters on Apollo's front panel.

These meters are before the monitor output level control (pre-fader) and reflect the level of the D/A converters at the monitor outputs.

Important: If clipping occurs, reduce levels feeding the monitor bus by lowering the channel faders and/or output gain(s) of UAD plug-ins within Console to eliminate undesirable D/A clipping distortion.

Meter Source

When the monitor output signals are changed with the [Monitor Output Options](#), the levels displayed by the monitor meters reflect the changed monitor outputs source signal.

Monitor Level Scale

The numerical labels represent digital signal levels. “0” represents 0 dBFS (digital full scale, the maximum level before undesirable A/D clipping). If the level of the monitor bus exceeds 0 dBFS, the meter's clip indicator(s) illuminates.

Peak Hold

The monitor meters also have a peak hold feature, which “holds” signal peak values for a specified period of time. The clip and peak hold times can be adjusted in the Display panel within the Console Settings window.

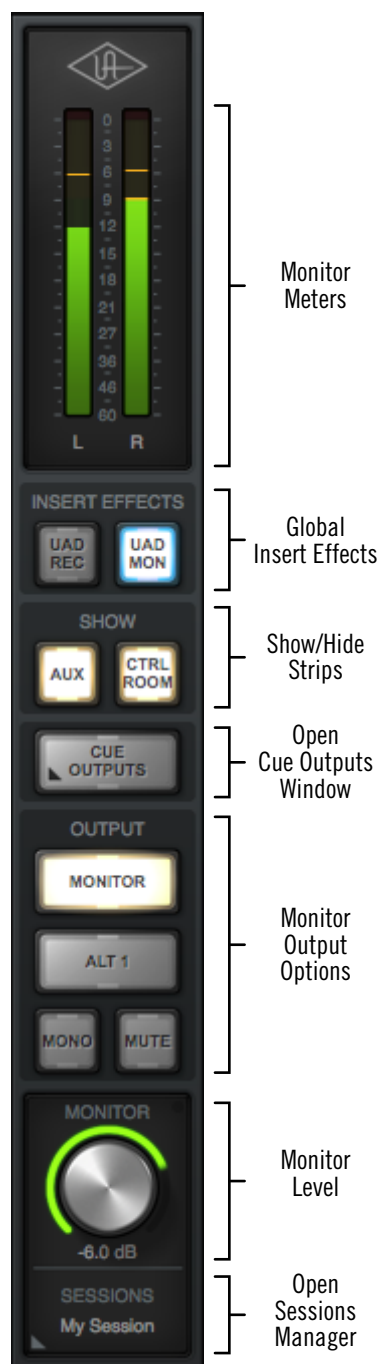

The Monitor Column

Global Insert Effects

These buttons globally switch all Console's inserts to either pass all UAD insert effect processing to the DAW (print wet) or not (monitor wet but print dry).

Insert Effects can also be individually switched on a per-channel basis (see [Channel Insert Effects](#)). The Global Insert Effects switches override all the individual Channel Insert Effects settings. See [Insert Effects Overview](#) additional details.

Important: UAD plug-in processing in Console's Unison and auxiliary inserts is always routed to the DAW (when recording the AUX channels), regardless of the current Insert Effects setting (Unison & aux insert processing is always recorded).

UAD REC (print all wet)

When this switch is lit RED and the UAD MON switch is off, all insert effects on all channels are routed to the DAW.



UAD MON (print all dry)

When this switch is lit BLUE and the UAD REC switch is off, no insert effects on any input channels are routed to the DAW (except Unison and aux processing, which is always recorded).



Both UAD REC and UAD MON (print wet and dry)

When both switches are lit YELLOW, some individual channels are recorded with insert processing and some are recorded dry, as determined by the [Channel Insert Effects](#) switches. Clicking one of the global insert effects switches will override the individual channel insert effects settings.



Show Strips

These switches show and hide the visibility of the auxiliary return strips and/or the control room options strip. By default, these strips are not visible. The strips are visible when its SHOW switch is engaged (lit).

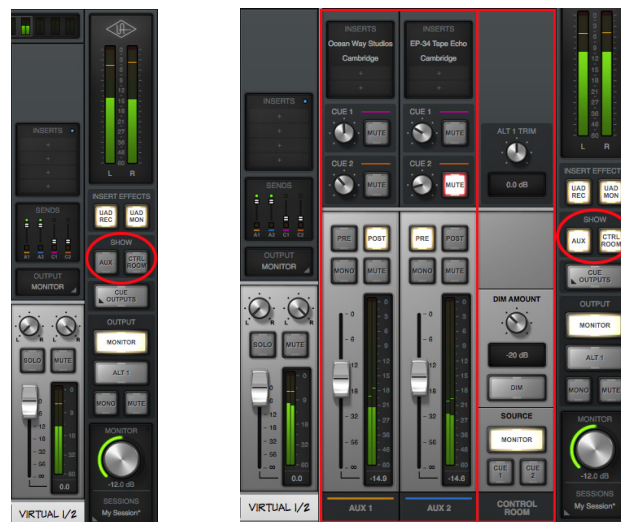

The SHOW buttons disengaged (left) and engaged (right)

Cue Outputs Menu

Clicking this menu opens the Cue Outputs popover window, where the cue mix buses can be routed and mirrored to various outputs.

For complete details, see [Cue Outputs Popover](#).

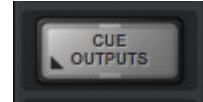

Monitor Output Options

Various monitor options are controlled with the switches in the OUTPUT section.

ALT 1, ALT 2

When ALT monitoring is enabled in the Hardware panel within the Console Settings window, ALT switches appear here to control which hardware outputs the monitor mix is routed to.

See the [ALT Monitoring Overview](#) for details about this feature.



Monitor Mono

This switch sums the left and right channels of the stereo monitor mix into a monophonic signal. The monitor output is stereo when the button is gray and mono when the button is lit.



Monitor Mute

This switch mutes Apollo's monitor outputs. The monitor outputs are muted when the switch is lit. This switch performs the same function as pressing the MONITOR knob on Apollo's front panel. The Monitor Level Indicator (the ring around the level knob) is red when the monitor outputs are muted.



Monitor Level

This is the master level control for Apollo's monitor outputs. It performs the same function as the MONITOR hardware knob on Apollo's front panel.



Monitor Level Value

The *specific* monitor output attenuation value in dB is displayed beneath the Monitor Level control. The *relative* monitor output level is indicated by the colored ring around the Level control (as with the MONITOR knob's LED ring on Apollo's front panel).

Monitor Output Gain Bypass (Apollo 8, Apollo 8p, Apollo 16 mkII)

When Monitor Output Gain in the hardware panel within Console Settings is set to BYPASS, the Monitor Level Value field displays BYP, the monitor level cannot be adjusted, and ALT monitoring and assignable FCN switch features are disabled. For related details, see [Monitor Output Gain \(Apollo 8, Apollo 8p, Apollo 16 mkII\)](#).



Monitor Output Gain bypassed

Monitor Level Indicator

In addition to indicating the relative signal level of the monitor outputs, the state of several other functions is indicated by the color of the ring around the monitor level control:

Green – The main monitor outputs are active with variable level control (normal)

Green (fixed at maximum) – Monitoring is bypassed in Console Settings

Red – The main monitor outputs (and ALT monitor outputs, if configured) are muted

Orange – The ALT 1 monitor outputs are active

Yellow – The ALT 2 monitor outputs are active

Flashing – The monitor DIM and/or MONO functions are active



Monitor level indications (from left to right): Normal, Bypass, Mute, ALT 1, ALT 2, and DIM/MONO

Apollo Twin Dot (Apollo Twin only)

When the Monitor Level function is active on Apollo Twin's hardware (when its white MONITOR indicator is lit), a green dot is visible in Console adjacent to the MONITOR text label, as circled in red at right.

The dot provides a visual indication that the MONITOR level adjust function is active on the Apollo Twin hardware. When the dot is *not* visible, adjusting Apollo Twin's hardware level knob will not adjust the monitor level.



Apollo Twin's
MONITOR dot

Sessions Switch

This switch is used to access the [Sessions Manager Popover](#) (single-click) or the [Sessions Menu](#) (right-click), where Console configuration preset files are managed. For complete details about these features, see [Console Sessions](#).

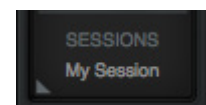

Cue Outputs Popover

Note: For an overview of Apollo's Cues, see [page 34](#).

The Cue Outputs popover window is where the cue mix bus returns are configured. Each cue mix bus has its own row of controls, as shown in the diagrams below.

Because the control set for each cue row is identical, each control in the rows are only described once.

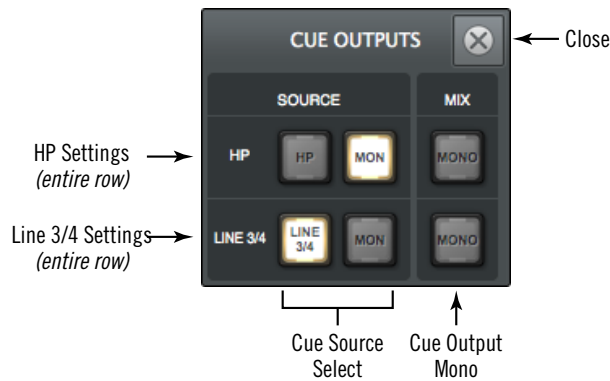

The Cue Outputs popover with Apollo Twin

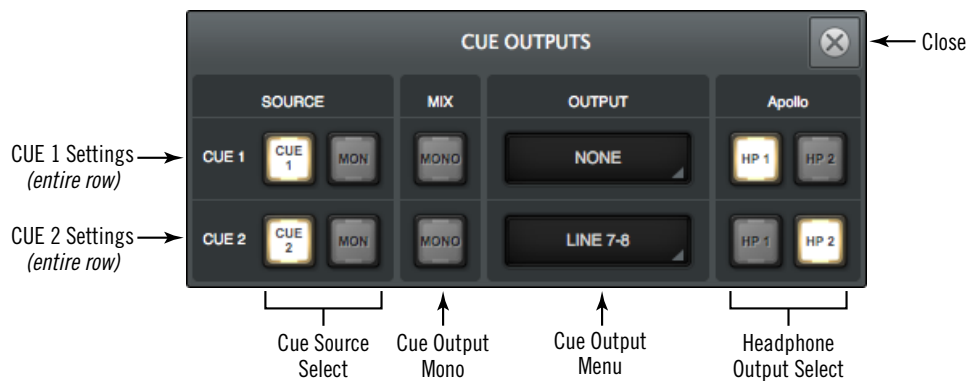

The Cue Outputs popover with Apollo, Apollo 8, Apollo 8p

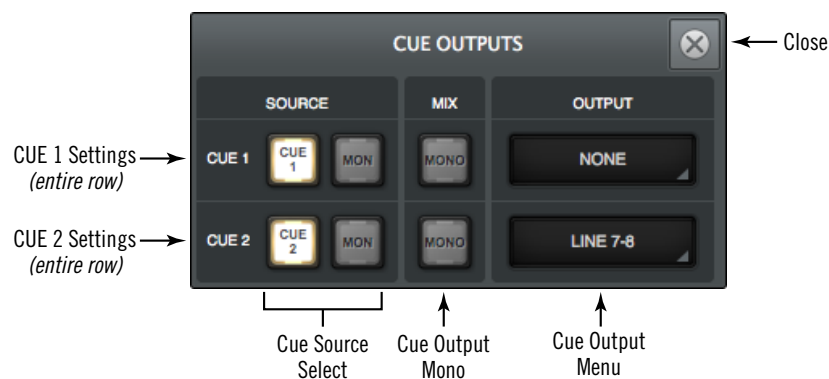

The Cue Outputs popover with Apollo 16

Cue Source Select

These two switches determine the input source for the cue output. The source for the cue is active when its switch is lit.

The source for each cue can be either the associated cue mix or the main monitor mix. The cue sources for each cue are mutually exclusive (both sources cannot be simultaneously active).

Note: To enable the ability to select the cue for the monitor outputs (via the control room [Monitor Source Select](#) switches), the cue's source must not be set to MON.

MON

When set to MON (the default), the cue source is Console's main monitor mix, summed with all DAW outputs that are routed to the monitor outs (if applicable). Console's main monitor mix faders, mutes and solos are reflected in the cue output in this mode.

CUE (Apollo Rack Models)

When set to CUE, the cue source is the dedicated cue mix, summed with all DAW outputs that are routed to the same cue outputs (if applicable). In this mode, the mix of the cue bus is determined by the cue send controls in the input channel strips and the aux return strips.

Console's faders, mutes, and solos are *not* reflected in the cue outputs in when CUE is selected (Console's cue sends are pre-fader).

Note: When CUE is the selected cue source, signals must be sent to that cue's mix bus (via the cue sends) for the cue mix to be heard in the selected outputs.



Cue Source select
(Apollo rack models)

HP & LINE 3/4 (Apollo Twin)

When set to HP, the headphone cue source is the dedicated HP mix, summed with all DAW outputs that are routed to the HP outputs (if applicable).

When set to LINE 3/4, the line outputs source is the dedicated LINE 3/4 mix, summed with all DAW outputs that are routed to the same cue outputs (if applicable).

In this mode, the mix of the cue bus is determined by the cue send controls in the input channel strips and the aux return strips.

Console's faders, mutes, and solos are *not* reflected in the cue outputs in when HP or LINE 3/4 is selected (Console's cue sends are pre-fader).

Note: When HP or LINE 3/4 is the selected cue source, signals must be sent to that cue's mix bus (via the cue sends) for the cue mix to be heard in the selected outputs.



Cue Source select
(Apollo Twin)

Cue Output Mono

This switch sums the left and right channels of the stereo cue mix bus into a monophonic signal. The cue output is stereo when the switch is gray and mono when it is lit.

Note: This switch only controls the cue's outputs. To hear the cue mix in mono when it is routed to the monitor outputs (via the Control Room Source switches), use the [Monitor Mono](#) switch instead.

Cue Output Menu (Apollo rack models)

This menu is used to optionally route the cue to Apollo's available hardware outputs. To select a hardware output pair for the stereo cue, click NONE and select an available output pair from the drop menu.

Important: The cue output route overrides the DAW output channels assigned to the same hardware output(s). In other words, if an output is in use by a cue output, it is no longer available to be assigned as an output within the DAW.

Tip: To route signals to both the cue and the desired stereo output, route to a dedicated cue bus via the Core Audio panel within the Console Settings window, then assign the cue to the desired stereo output via the Cue Output menu.

Cue output assignments are mutually exclusive. When a cue output route is assigned, that output becomes unavailable for routing from a different cue bus (cue mix buses cannot be merged to the same outputs).

Note: If an output does not appear in the menu, the output is already in use by another input channel (Flex route), cue output, or ALT output.

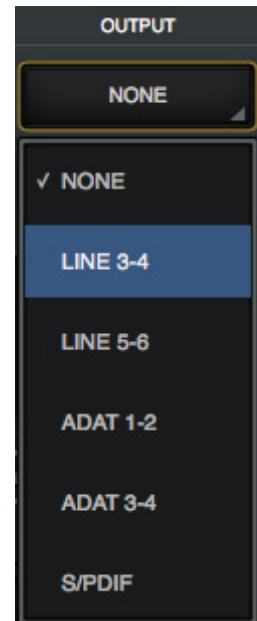

Cue Output menu

Headphone Output Select (Apollo, Apollo 8, Apollo 8p)

These switches determine which Apollo headphone output the cue is routed to. The headphone outputs are mutually exclusive (each headphone output can have only one source).

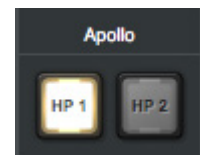

Control Room Column

The control room column is where various options for the monitor outputs are configured and selected.

Show Column

By default, the control room column is not visible. To show the column, enable the CTRL ROOM switch in the SHOW section of the monitor column.

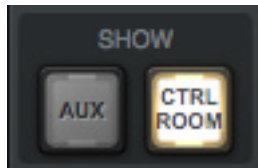

The Show CTRL ROOM switch in the monitor column

ALT Trim Controls

The ALT trim controls are typically used to compensate for different levels of the alternate monitor speakers so they have the same apparent volume as the main monitor speakers.

Note: ALT controls are only visible when the ALT COUNT menu in the Hardware panel within the Console Settings window is set to a non-zero value.

See [“ALT Monitoring Overview” on page 38](#) for more details.

ALT Level – Adjusts the output level of the main monitor mix when it is routed to a different pair of Apollo line outputs via the ALT monitoring function. The default value is 0 dB with an available range of ± 30 dB.

ALT Value – The current ALT level value in dB is displayed.

DIM Controls

DIM is used to quickly reduce the listening volume in the control room by a set amount and quickly return to the prior volume.

DIM Amount – This control adjusts the amount of attenuation level that is applied to the main monitor mix when the DIM switch is engaged. The default value is -20 dB with an available range of 0 dB to -60 dB.

DIM Enable – When engaged (lit), the monitor outputs (and ALT outputs, when active) are attenuated by the DIM Amount value.

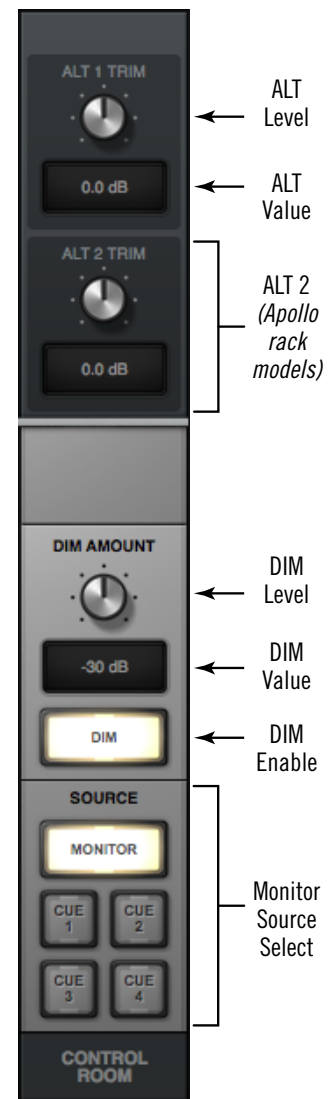

Control Room column

Monitor Source Select

These switches select the mix bus that is sent to Apollo's monitor outputs. The source is selected when its switch is lit.

Monitor

When MONITOR is selected, the main monitor mix, summed with any DAW outputs assigned monitor outputs (if applicable), is routed to the monitor outputs.

Cue 1, 2, 3, 4 (Apollo rack models)

When a CUE is selected, that cue mix (the mix created from cue sends in Console), summed with any DAW outputs assigned to the cue (if applicable), is routed to the monitor outputs.

HP, LINE 3/4 (Apollo Twin)

When HP or LINE 3/4 is selected, the respective cue mix, summed with any DAW outputs assigned to the respective HP or LINE 3/4 outputs (if applicable), is routed to the monitor outputs.

CUE INACTIVE Dialog

CUE, HP, or LINE 3/4 can be selected as a monitor source only if its respective source in the [Cue Outputs Popover](#) is *not* set to MON.

Allowing those settings would be the same as simply selecting MONITOR as the source with the monitor source select, except that you wouldn't be able to determine the current route without opening the cue outputs window.

If the CUE INACTIVE dialog appears when attempting to enable a cue as the monitor source, close the dialog then open the CUE OUTPUTS window and switch that cue's source from MON to the cue mix.

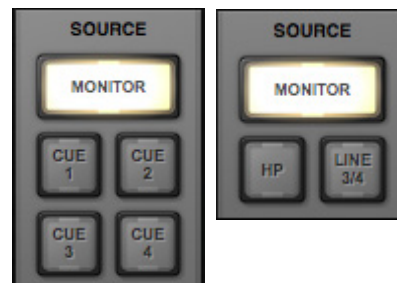

Monitor source select switches with Apollo rack models (left) and Apollo Twin (right)

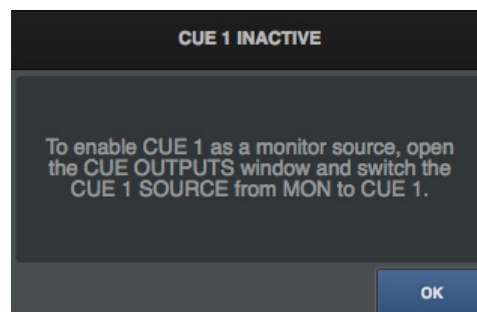

Console Sessions

The Sessions controls provide methods for managing complete Console configurations as session preset files. When a Console session file is saved, the current Console configuration is written to disk.

When a session file is subsequently reloaded, Console is returned to the exact same configuration state, regardless of any changes to Console that were made in the interim.

Content of Session Files

Console session files contain most, but not all, Console settings. The specific parameters saved and not saved are listed below:

Saved – All knob, slider, and menu values, all inserted UAD plug-ins, settings contained within the plug-ins, and settings in Console Settings window (except those listed below).

Not saved – All Monitor Gain, Line Output Reference Levels, Clock Source, Sample Rate, Monitor Outputs Digital Mirror, Cue Outputs, and Core Audio settings are global parameters that are not session-specific. Most of these settings are managed in the Console Settings window.

Tip: Core Audio settings can be saved separately in the [I/O Presets Popover](#).

Default Session Files Location

By default, session files are saved to, and loaded from, the user's home folder at:

- ~/Documents/Universal Audio/Sessions/

Although session files can be saved to (and loaded from) any location on disk, using the default location enables the most convenience because Console always uses this location for the Sessions Manager window and also Open/Save dialogs presented by the OS.

Note: Session files must reside in the default location to appear in session lists within Console.

Sessions Sub-Folders

The Session Files folder can contain one level of sub-folders for additional session organization capability. The contents of sub-folders (if any) are displayed in the SUB-FOLDER column when a folder in the SESSION column is selected.

Session Files Suffix

Console's session files have the “.uadmix” suffix. The suffix is added to session files automatically when saving to disk; however, the suffix is not displayed in the file save dialog (the suffix should not be manually typed when saving a session file).

Note: Without the .uadmix suffix, the session files will not be visible in the “Open” file dialogs or the Sessions menu, and they won't be opened when they are double-clicked in the OS file system.

Session Files Access

Session files can be saved and loaded via several methods: The [Modified Session Dialog](#), the File menu in the [Application Menus](#), and/or the [Sessions Menu](#).

Session Name

Session names are displayed in the [Meter Bridge](#) at the top of the main Console window (“My Session” in the screenshot below), below the word SESSIONS within the [Settings Switch](#), and at the top of the Sessions Manager window. Session names are created when the file is saved; they can also be renamed via the OS file system.

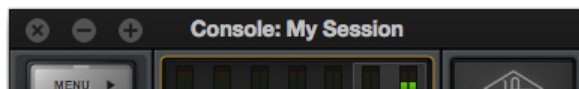

Modified Session Name

When any Console setting is changed after the session was saved, an asterisk (*) appears after the session name, as shown at right. This is a convenient visual reminder that the session is modified and may need to be saved for future use. To clear the asterisk, save the session.

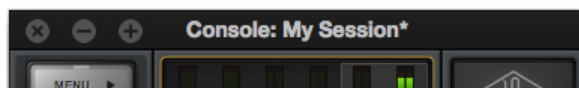

SYNC Session Name

When a DAW project containing the Console Recall plug-in is opened that has the SYNC function in the plug-in enabled, the session name changes to “- Sync Session -” indicating that the DAW has sent session settings to Console. See [SYNC](#) for related details.

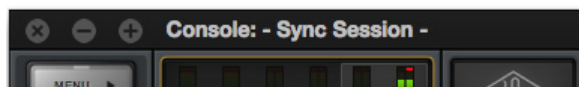

Modified Session Dialog

If the current Console session has been modified and a new Console session is loaded, a dialog displaying the current session name in quotes appears with option switches (the session name in quotes does *not* appear if the session has never been saved). The behavior of the option switches in this dialog are detailed below.

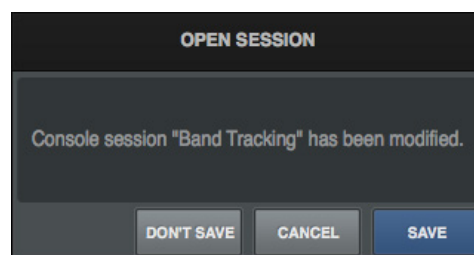

Important: This dialog does not appear when a Console session is loaded via the Console Recall plug-in’s SYNC function. See [SYNC](#) for details.

Don’t Save – All modifications to the current Console session are discarded and the session is loaded (or created, if new session).

Cancel – The current Console session remains active and the attempt to load the Console session file is canceled.

Save – The current session is saved to disk and the session is loaded. If the session has never been saved to disk, this switch displays “Save As...” which opens the file save dialog.

Sessions Manager Popover

The Sessions Manager popover window is where Console session preset files are managed. The Sessions Manager window contains the SESSION and SUB-FOLDER columns and several function switches. The columns and switches are used to navigate and manage the session files.

Refer to the illustration below for descriptions in this section.

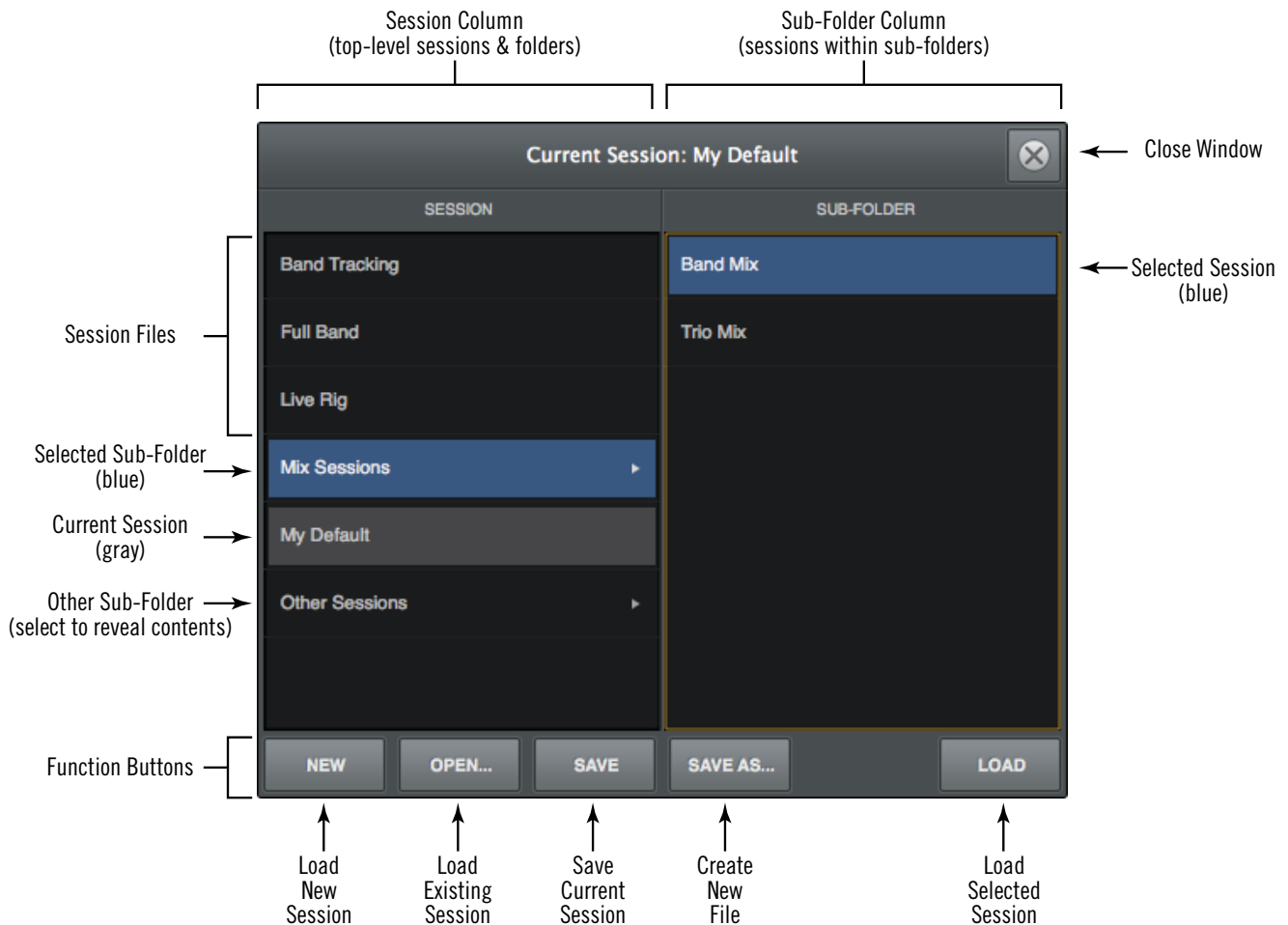

The Sessions Manager popover

Sessions Switch

To access the Sessions Manager window, single-click the Sessions Menu located at the bottom of the Monitor Column.

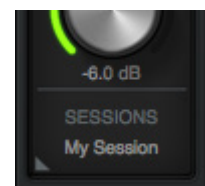

Click to open the Sessions Manager

Sessions Manager Contents

Session folder contents can be organized via the OS X Finder. File locations in the Finder are reflected within the Sessions Manager.

SESSION Column

All items within the [Default Session Files Location](#) are displayed in the SESSION column. If more sessions or folders reside in the column than are currently within view, a scroll bar appears.

Double-click any session in the SESSION column to load it, or click a sub-folder (if any) to display sessions within the sub-folder in the SUB-FOLDER column.

Note: Sub-folders are indicated in the SESSION column by small disclosure triangles near the right side of the SESSION column.

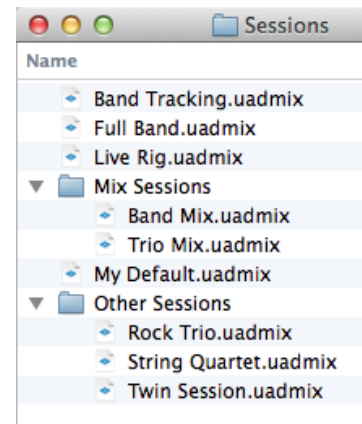

Sessions Manager contents shown in OS X Finder

SUB-FOLDER Column

If the SESSION column contains one or more folders, selecting the folder will display its contents in the SUB-FOLDER column. Double-click any session in the SUB-FOLDER column to load it.

Sessions Manager Function Switches

The Sessions Manager contains switches that perform file management tasks. Click a switch to perform the operation on the currently selected preset or sub-folder.

New

Creates a new Console session with default settings (default settings cannot be changed). If the current session has been modified, a dialog appears allowing you to save it first.

Open...

Opens the operating system's standard "Open File" dialog for loading existing session files from disk.

Tip: Session files can also be opened by double-clicking .uadmix files from within the OS's file system.

Save

Saves the current modified preset file in place. If the preset was not previously saved (if the file doesn't exist), the Save As window appears.

Save As...

This option opens the operating system's standard file save dialog window so the current session can be named and saved to disk as a new session file.

Important: Session settings will not be properly saved if the "/" (forward slash) or "?" (question mark) characters are in the filename. Avoid these and other special characters when saving session files.

Load

Loads the session that is currently selected within the Presets Manager window (a session is selected when highlighted in blue).

Tip: A session can also be loaded by double-clicking the session or typing Return (or Enter) when the session is selected.

Sessions Menu

The Sessions Menu provides quick access to sessions functions without opening the Sessions Manager. Click any item in the menu to perform the function.

Items in the menu are divided into three sections. File management options are in the top section, existing session files and folders that reside on disk are listed in the center section, and cached (overwritten) sessions are listed in the bottom section.

Display Sessions Menu

To access the Sessions Menu, right-click the Sessions Switch located at the bottom of the Monitor Column. When the menu is displayed, clicking an item in the menu chooses that item.

Refer to the diagram on the next page for Sessions Menu descriptions.

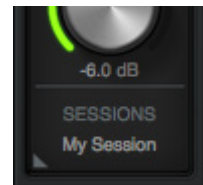

Right-click to show the Sessions Menu

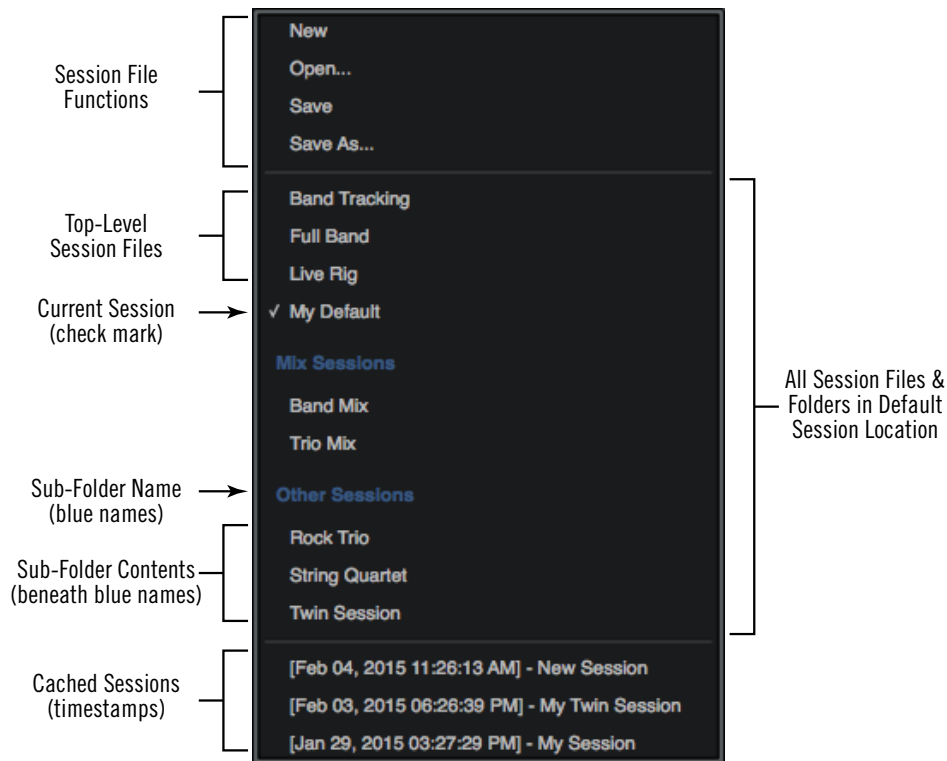

The Sessions Menu

Session File Functions

The New, Open, Save, and Save As functions listed here have the same functionality as the [Sessions Manager Function Switches](#).

Sessions List

Existing session files that reside in the [Default Session Files Location](#) are displayed in the center section of the sessions menu. (Session names in diagram are examples only.)

Select a session from the list to load the session file. If the current session has been modified, the Modified Session Dialog appears.

Note: Session files must reside in the [Default Session Files Location](#) and have the `.uadsession` suffix to be visible in the Session Menu.

Sub-Folders

Sub-folder names in the Sessions Menu are displayed in blue. Session files within the sub-folder are displayed beneath the blue sub-folder name (session files not within sub-folders appear at the top of the sessions list).

Cached Sessions

Cached sessions appear in the bottom section of the Sessions Menu. Cached sessions are the same as session files, except they don't reside in session files on disk. Instead, these sessions are automatically created and stored in a temporary cache.

Why Cached Sessions Exist

When a DAW project containing the Console Recall plug-in is opened and the plug-in's SYNC function is enabled, the Console settings contained in the DAW project overwrite the current Console settings. The cached sessions are used to recover the overwritten data if desired. See [SYNC](#) for details about the feature.

When Cached Sessions Appear

A cached session is automatically created every time a DAW project containing the Console Recall plug-in is opened and the plug-in's SYNC function is enabled. In this scenario, the SYNC function loads the Console session contained in the DAW project, and the previously-active Console settings are moved into the cached sessions menu.

The previously-saved Console session's filename is retained in the cached session, and a timestamp is prefixed so it can be easily distinguished from other sessions. The five most-recently cached sessions appear in the list.

Window Title Bar

The Window Title Bar is the topmost strip in the Console and Console Settings windows, as shown below.

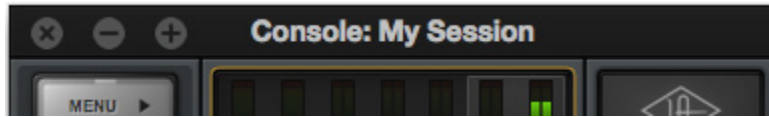

The Window Title Bar

Window Name – In the main Console window, the current session filename is displayed in the title bar. If the session has not yet been saved to disk, “Console” is displayed here.

Close – Clicking the “x” button closes the Console or Console Sessions window. If the window is the last open window, the Console application is quit.



Note: Console’s current settings are saved to disk when quit; when Console is subsequently launched, those settings are transferred to Apollo.

Minimize – Clicking the “-” button reduces the window to the OS X Dock. The window can be restored by clicking the minimized window, or any [Accessing Console](#) method detailed on [page 19](#).



Zoom – Clicking the “+” button expands the Console window to the maximum size available on the screen where the window currently resides.



Application Menus

Various Console functions can be accessed from the Application Menus. Selecting an item from the drop menu performs the function.

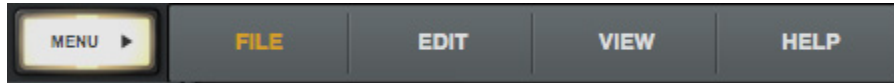

Console's Application Menus

Tip: Many menu functions can also be accessed using the keyboard shortcuts shown next to the item in the menu.

Menu Button

The Menu button displays the application menus. The button is located at the upper left of the main Console window, at the top of every View Column.

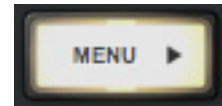

File Menu

Session Files Location

By default, all Console session files are stored at the following location within the Mac OS X file system (the same location used by the [Sessions Manager Popover](#)):

- ~/Documents/Universal Audio/Sessions

Tip: Console sessions can be organized via the OS X Finder. File locations in the Finder are reflected within the Sessions Manager.

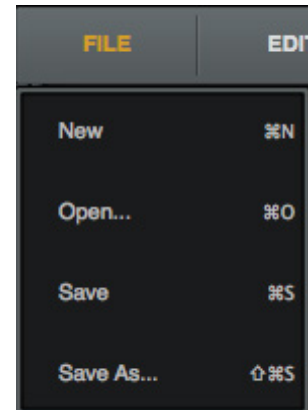

New

Creates a new Console session with default settings (default settings cannot be changed). If the current session has been modified, a dialog appears allowing you to save it first.

Open...

Opens the operating system's standard "Open File" dialog for loading existing session files from disk.

Session files can also be opened by double-clicking .uadmix files from within the OS's file system.

Save

If a session file was previously saved, selecting this option writes the current settings to the file with the same name, overwriting the previously saved file.

If the current session has never been saved, the operating system's standard "Save File" dialog appears so a new session file can be named and saved to disk.

Save As...

This option opens the operating system's standard "Save File" dialog so the current session can be named and saved to disk as a new session file.

Important: Session settings will not be saved if the "/" (forward slash) or "?" (question mark) characters are in the filename. Avoid these and other special characters when saving session files.

Edit Menu

Note: See [Multiple Undo/Redo](#) for an overview of Undo/Redo.

Undo

When a parameter value in the Console window is edited, the change can be reverted with the Undo command. By executing Undo again, edits can be stepped backwards repeatedly.

The number of Undo steps is essentially unlimited. The Undo cache is active until a new or different session is loaded or Console is quit.

Redo

When the Undo function (above) is executed, the original edit can be restored with the Redo command. By executing Redo again, previous Undo's can be restored repeatedly.

The number of Redo steps is essentially unlimited. The Redo cache is active until a new or different session is loaded.

Remove All

All plug-ins can be categorically deleted from Console by selecting an item from the sub menu.

Enable All

All plug-ins can be categorically enabled from Console by selecting an item from the sub menu.

Disable All

All plug-ins can be categorically enabled from Console by selecting an item from the sub menu.

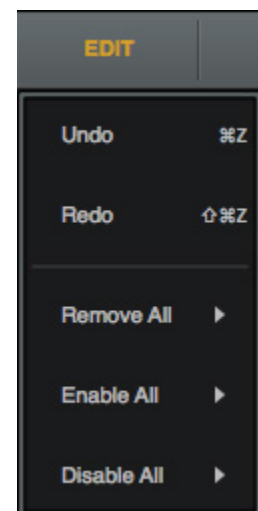

Remove/Enable/Disable Sub-Menu

Plug-Ins – The function is performed on all Console plug-ins.

Insert Plug-Ins – The function is performed on all channel insert plug-ins. Aux and Unison plug-ins remain inserted.

Aux Plug-Ins – The function is performed on all auxiliary plug-ins. Channel and Unison plug-ins remain inserted.

Unison Plug-Ins – The function is performed on all Unison plug-ins. Channel and aux plug-ins remain inserted.

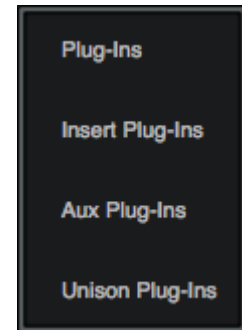

View Menu

Show/Hide Items

Show/Hide Aux Returns

Shows the aux returns when they are hidden, and hides them when they are visible. This item performs the same function as the [Show Aux Returns](#) switch in the monitor column.

Show/Hide Inputs



Allows unused Console inputs to be hidden from view. For details, see [page 73](#).

Show/Hide Offline Devices

Shows offline devices when they are hidden, and hides them when they are visible. This feature is typically used for adjusting Console sessions in multi-unit configurations when all Apollo devices are not currently connected.

View Items

Note: Items in this section perform the same function as clicking the View switches in the View column.

Overview – Switches Console to Overview view.

Inputs – Switches Console to Inputs view.

Inserts – Switches Console to Inserts view.

Sends – Switches Console to Sends view.

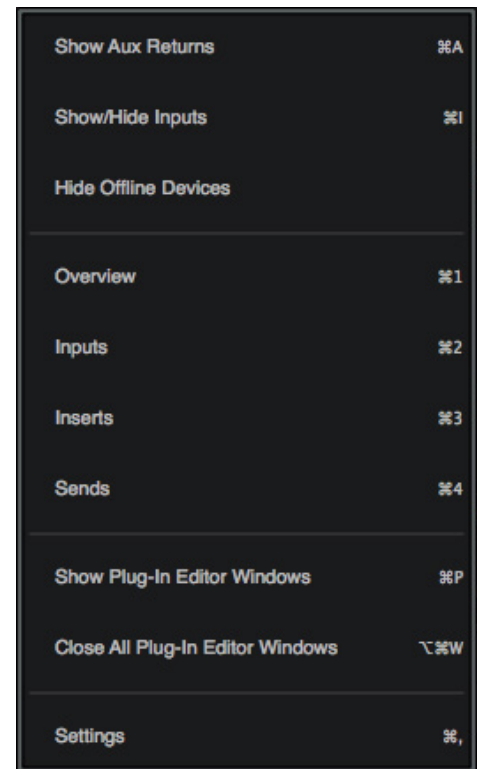

Show Plug-In Editor Windows

Brings all open UAD plug-in editor windows to the foreground (if any). If ALWAYS ON TOP in the Display panel within the Console Settings window is set to PLUG-INS, this function has no effect (plug-in editors are always in the foreground in this mode).

Note: This item applies only to UAD plug-ins used within Console, not those used within a DAW.

Close All Plug-In Editor Windows

Closes all open UAD plug-in editor windows (if any).

Settings

Opens the Console Settings window, where various global parameters are configured. See [Sessions Manager Popover](#) for details about the window.

Help Menu

Documentation

This item opens the folder containing all Apollo product user documentation files. Consult the documentation when you need specific operational information.

After opening the folder, double-click a documentation file to open it.

Tip: Use the search function within the PDF reader application to quickly find information about a particular topic.

Contents of the documentation folder:

- Apollo Software Manual (this file)
- Apollo Hardware Manuals for each unique model
- UAD System Manual
- UAD Plug-Ins Manual
- Direct Developer (3rd-party) plug-in manuals

Note: For related information, see the [Apollo Documentation Overview](#).

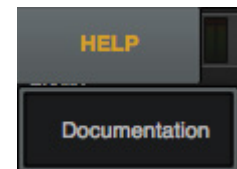

Chapter 5: UAD Plug-In Inserts

The Inserts section of each input strip is where UAD Powered Plug-Ins are selected and used for Realtime UAD Processing. Four insert slots are available per Console channel strip; therefore up to four UAD plug-ins can be serially chained (stacked) per input within the constraints of available DSP resources.

Note: Only UAD Powered Plug-Ins can be loaded in Console. However, tracks with non-UAD plug-ins used within a DAW can be routed into Console via [Virtual I/O](#).

Inserts Display

The inserts display shows the name of currently loaded plug-ins (if any). An abbreviated name is shown for longer plug-in names due to space constraints. In expanded views, an icon representing the plug-in is also displayed.

Refer to the illustration below for element descriptions in this section.

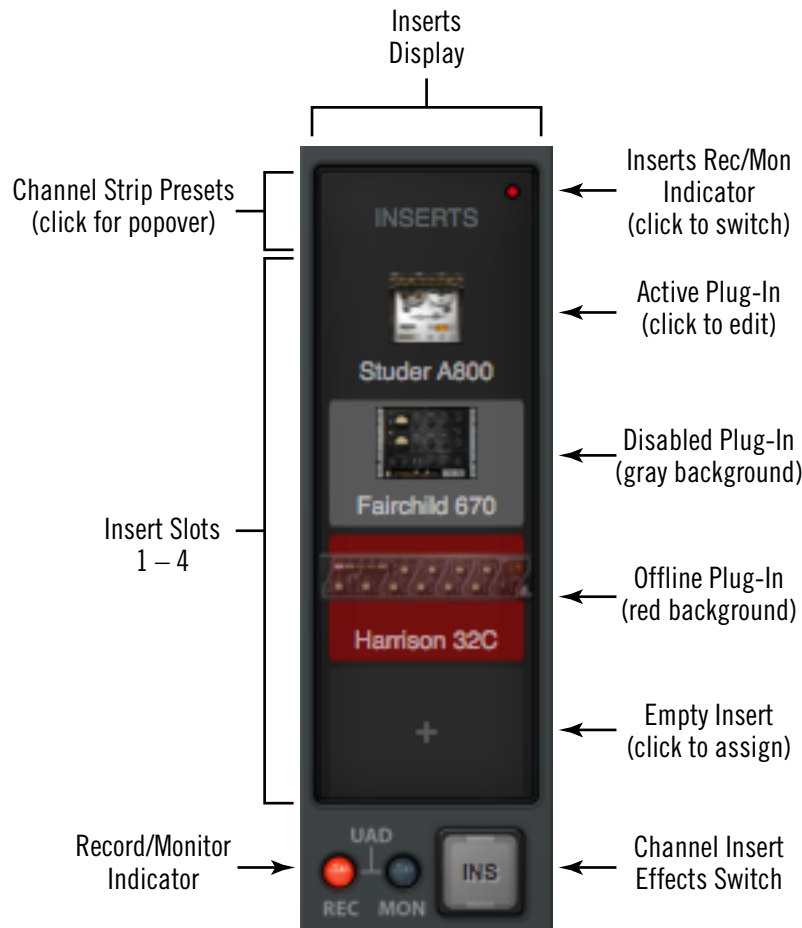

The Channel Inserts

Signal Flow

Audio signals in a Console channel flow through the inserts serially from top to bottom. Therefore, if more than one plug-in is inserted in a channel, the location of a plug-in within the inserts can impact the sound of the channel. Plug-ins can be reordered by dragging them to change the serial processing order.

Unison Insert

Apollo's Unison technology is activated when a Unison-enabled UAD plug-in is loaded in the dedicated Unison insert located above the preamp options (as shown at right, outlined in red).

Note: Audio on preamp channels is processed by the Unison insert (if active) before the channel inserts.

The Unison insert is only available on Apollo preamp channels. However, Unison inserts are operated exactly the same way as standard channel inserts. See [Chapter 8: Unison](#) for related information.



Click area outlined in red to insert a Unison plug-in

Insert Assign Popover

Clicking any empty insert slot displays the Plug-Ins Manager popover window. Click any UAD plug-in from any category in the popover to load the plug-in into the insert.

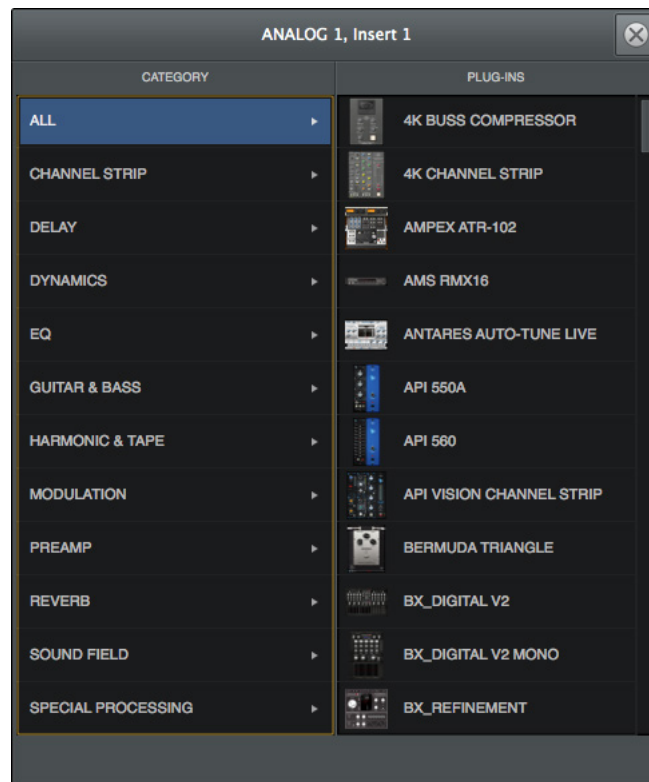

The Insert Assign popover

Important: UAD Powered Plug-Ins within Console use DSP differently than when used within a DAW. To maintain the lowest possible input latency, UAD plug-ins used on a single Console channel strip must run on a single SHARC processor. Therefore, it is possible to get a “DSP load limit exceeded” message on a channel even though the UAD gauges may indicate there is enough DSP available.

Edit Plug-In

If the insert already contains an assigned plug-in, clicking the insert opens the [Plug-In Editor Window](#), where plug-ins can be adjusted and/or plug-in presets can be managed.

Insert State Indicators

The state of loaded UAD plug-ins within each insert can be determined by the background color of the slot:

Active (dark gray) – The plug-in is active and processing audio. The Studer A800 insert at right indicates this state.

Disabled (light gray) – The plug-in has been disabled via the power switch in the header of the plug-in edit window (or via the disable function in the insert options menu). The Fairchild 670 plug-in at right indicates this state.

Note: Disabling a plug-in via the power control within its editor window (versus the Power switch in editor view) does not change the background color.



State Indications

Offline (red) – The plug-in is disabled because there is not enough UAD resources, it is unlicensed and the demo has expired, and/or the UAD authorization needs updating. The Harrison 32C insert at right indicates this state.

Empty (+) – The insert is not populated with a plug-in. Click the “+” symbol to open the Assign window for loading a plug-in into the insert.

Insert Hover Options

Three commonly-used plug-in functions become available when the mouse cursor is hovered over any insert containing a plug-in.

The function icons appear on top of the plug-in name, as shown at right. To perform the function, click the associated hover switch.

Remove – Unloads the plug-in from the insert.

Assign – Opens the Assign popover window to replace the current plug-in with a different plug-in.

Power – Disables/Enables plug-in processing and conserves UAD resources. The plug-in remains in the insert.

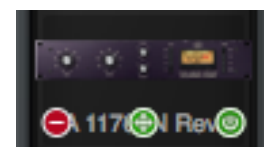

Remove Assign Power

Insert Options Menu

To display the Insert Options menu, right-click (or control+click) any insert.

The options available in the menu vary depending on the state of the insert (e.g., empty or loaded) and contents of the copy/paste clipboard. Each insert option is described below.

The menu has two sections under blue headings: Plug-in options that apply to the individual insert, and Channel options that apply to all channel inserts in the strip.

Plug-In Options

Copy – Copies the plug-in that is in the insert so it can be pasted into another insert. This option does not appear if a plug-in is not loaded in the slot.

Paste – Pastes a plug-in that was previously copied into the insert. This option does not appear if a plug-in was not previously copied.

Note: All copy/paste functions also copy/paste the current settings of the plug-in.

Assign – Opens the Assign popover window for selecting an insert plug-in. If the insert already contains a plug-in, the loaded plug-in is replaced with the newly-assigned plug-in.

Remove – Unloads the plug-in from the insert.

Disable – Disables plug-in processing and conserves UAD resources, but the plug-in remains in the insert.

Channel Options

Presets – Opens the channel presets popover window for managing channel presets.

Open Channel Strip – Opens the channel strip editor, where all plug-ins in the channel inserts can be viewed and managed within a single window.

Remove All – Unloads all plug-ins from all channel inserts in the channel.

Disable All – Disables plug-in processing and conserves UAD resources for all plug-ins in the channel inserts, but the plug-ins remain in the inserts.

Enable All – Resumes plug-in processing for all disabled plug-ins in the channel inserts.

Open Channel Strip – This feature groups and displays the interfaces of all plug-ins currently loaded in the inserts of a strip in a single window, offering a convenient method of organizing channel plug-in windows. The single window, containing up to four plug-in GUIs, can be moved and arranged on screen as desired in a single motion. See [Channel Strips](#) for details.

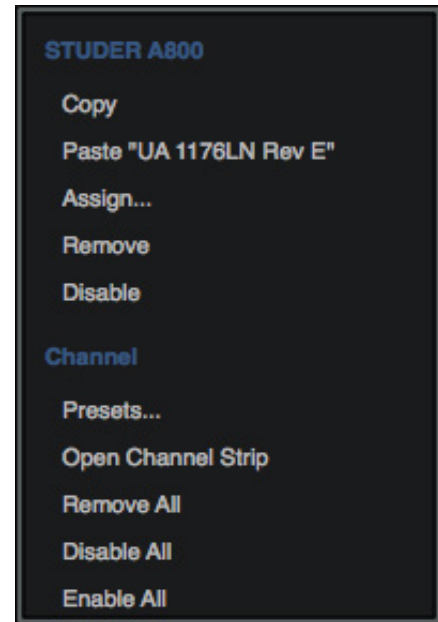

Insert Options Menu

Channel Insert Effects

Note: For an overview of Insert Effects, see [page 33](#).

Channel Insert Effects Switch

This switch determines whether or not Realtime UAD Processing occurring within an individual Console input is routed to the associated DAW input. For additional details, see [Global Insert Effects](#).

Tip: Insert Effects can be switched for all channels simultaneously with the [Global Insert Effects](#) switch.

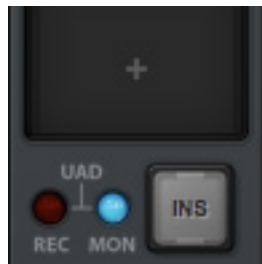

Channel Insert Effects Switch
(INPUTS display only)

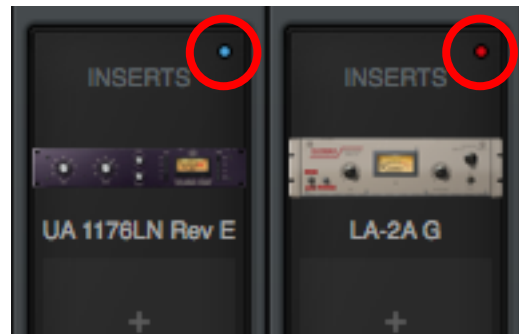

Channel Insert Effects Switch
(OVERVIEW & INPUTS display)

The large channel insert effects switch (above left) is visible when the INPUTS display is active. A smaller switch is available in both the INPUTS and OVERVIEW displays. In either view, click the INS switch (or a colored indicator) to change the state.

REC (print wet) – The indicator is RED and UAD processing in all inserts in the channel is routed to the associated DAW input for recording.

MON (print dry) – The indicator is BLUE and the unprocessed signal is routed to the DAW input. UAD processing is heard in monitor outputs only.

Important: UAD plug-in processing in Console's Unison and auxiliary inserts is always routed to the DAW (when recording the AUX channels), regardless of the current Insert Effects setting (Unison & aux insert processing is always recorded).

Plug-In Editor Window

Clicking any insert that contains a plug-in opens the editor window, where UAD plug-in parameters can be adjusted and/or plug-in presets are managed.

Multiple editor windows can be open simultaneously. By default, each opened editor window is offset so one window doesn't completely cover another.

Tip: To open each editor window at the same screen location, shift+click the insert.

Refer to the illustration below for element descriptions in this section.

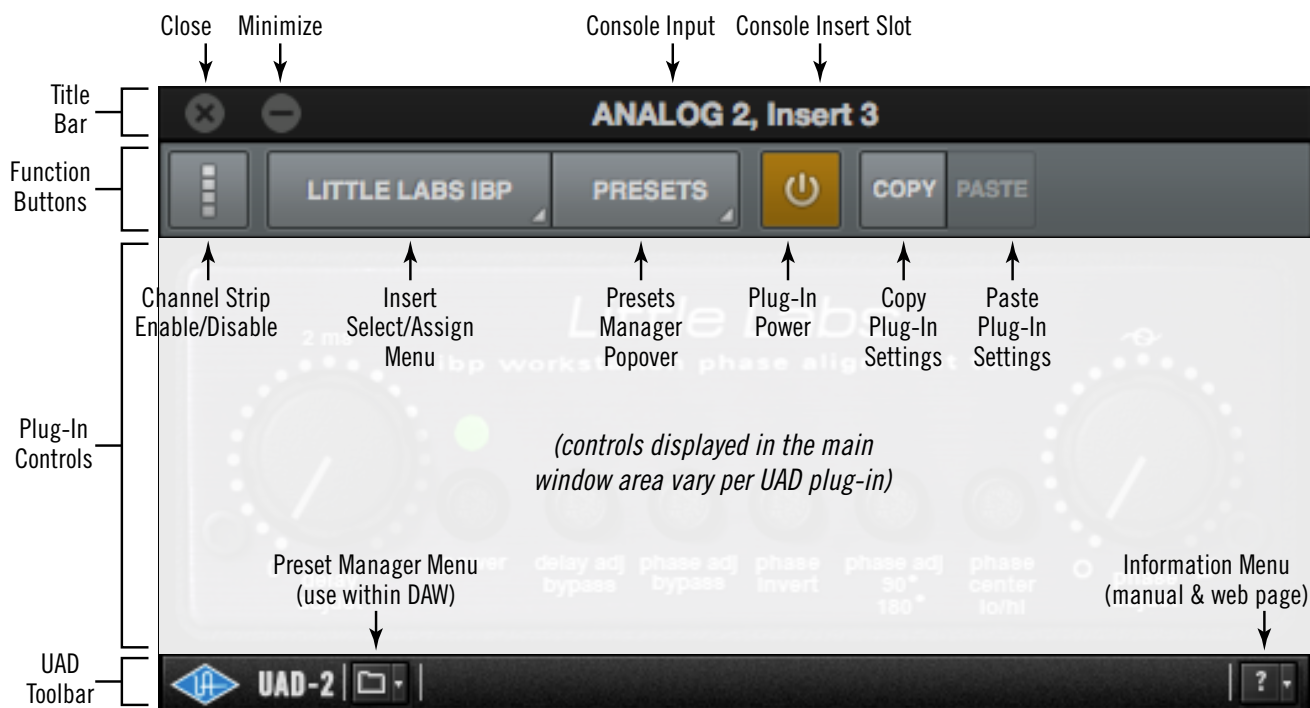

The Plug-In Editor Window

Title Bar

The editor window's title bar is displayed at the top of each editor window.

Console Input – The Console input containing the insert is displayed.

Console Insert – The insert slot number (1 – 4) or "Unison" is displayed.

Close – Closes the editor window.

Minimize – Minimizes the editor window by placing it in the OS X Dock. Click the minimized window in the Dock to restore it.

Function Switches

The function switches appear between the title bar and the plug-in controls.

Channel Strip Enable/Disable

This switch engages Channel Strip mode, all UAD plug-ins within the channel inserts can be controlled within a single window. For details, see [Channel Strips](#).

Insert Select/Assign Menu

This switch presents the Select/Assign drop menu, where different inserts can be selected for editing, or a different plug-in can be assigned to the current insert.

Select

When more than one insert is populated in the channel, choosing a different plug-in from the menu selects that plug-in for editing. In the example at right, three of the channel's inserts are populated. If only one insert is populated, only the current plug-in is displayed.

Assign

Choosing this menu item opens the plug-in assign popover window, for replacing the plug-in currently in the insert.

Note: When a plug-in is replaced via the assign function, any customized settings in the replaced plug-in are lost (if they weren't saved as a preset). However, they can be recovered until a different Console session is loaded by using the Undo function.

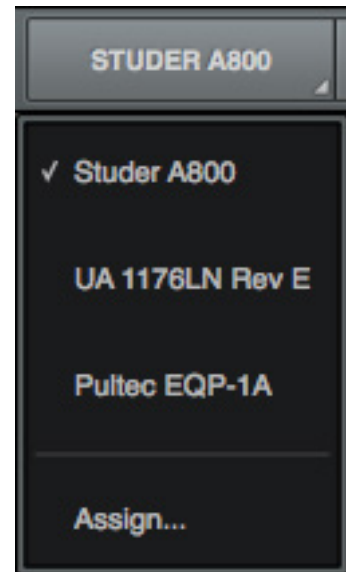

The Select/Assign menu

Presets Manager Popover

This switch presents the Presets Manager popover window, where plug-in settings can be saved and loaded. For details, see [Presets Manager](#).

Note: With narrow plug-ins, the switch icon at right is displayed instead of the word "PRESETS."

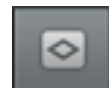

Plug-In Power

This switch deactivates the insert's plug-in by unloading it from the SHARC processor. When deactivated, the plug-in no longer uses UAD resources.

Click the switch to change the state. The plug-in is enabled when the switch is orange in color, and deactivated when the switch is gray. Deactivated plug-ins are indicated in the channel inserts by a light gray background.

Important: Because this function unloads and loads the plug-in from the DSP, audio artifacts can occur if the enable state is changed while audio is being processed by the plug-in. To disable individual plug-in processing without audio artifacts, use the power control within the plug-in interface instead, which keeps the plug-in loaded on the DSP.

Copy Plug-In Settings

This switch copies the parameter settings of the plug-in to the clipboard so they can be pasted into another instance of the same plug-in.

Paste Plug-In Settings

This switch pastes plug-in parameter settings, that were previously copied to the clipboard, into the current plug-in. If the switch is unavailable (gray), no settings are available in the clipboard or the plug-in title is different.

Note: Copied plug-in settings can only be pasted into the same plug-in title.

UAD Toolbar

The UAD Toolbar is displayed at the bottom of each UAD plug-in, including when the plug-in is used within a DAW (outside of Console).

For complete UAD Toolbar details, see the UAD System Manual.

Preset Manager Menu

This drop menu can be used to manage UAD presets within a DAW. To manage presets within Console, the [Presets Manager](#) instead.

Note: The [Presets Manager](#) is recommended for managing presets within Console (instead of the UAD Toolbar) because of its superior functionality.



Information Menu

This drop-menu contains two shortcuts for accessing information about the UAD plug-in.

Manual – Opens the UAD Plug-Ins Manual for UA-developed plug-ins, or the manual provided by the developer of 3rd-party plug-ins.

Web Info – Opens the default web browser and goes to the plug-in product page on the Universal Audio website (internet connection required).

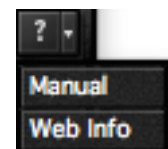

Channel Strips

Channel Strips are where all UAD plug-ins within the four channel inserts are displayed and controlled within a single editor window.

Note: *Unison plug-in editors in preamp channels are not included within Channel Strips. However, Unison preamp settings are stored within [Channel Strip Presets](#).*



The Channel Strip editor window

Channel Strip Enable

To merge all of a channel's plug-ins into a single window, click the Channel Strip Enable switch within any plug-in in any channel insert.

To disable Channel Strip mode and return to viewing the channel plug-ins individually, click the switch again.



Click the Enable switch to activate Channel Strip view

Channel Strip Presets

A Channel Strip preset contains all settings for all plug-ins within the channel strip. Channel strip presets are saved and/or loaded via the [Presets Manager](#).

Accessing Channel Strip Presets

The Presets Manager for Channel Strips can be accessed with these two methods:

- Click the Presets Manager button within the Channel Strip edit window.
- Click the word “INSERTS” in the area above the channel inserts in OVERVIEW or INSERTS views (as shown at right). This method can be used to load Channel Strip presets when plug-ins are not already loaded in the channel inserts.



Click “INSERTS” to access Channel Strip presets

Presets Manager

The Presets Manager is where individual UAD plug-in settings and Channel Strip settings are managed after a plug-in is assigned to an Insert. Preset tasks are performed in the Presets Manager popovers, which are accessed from the [Plug-In Editor Window](#).

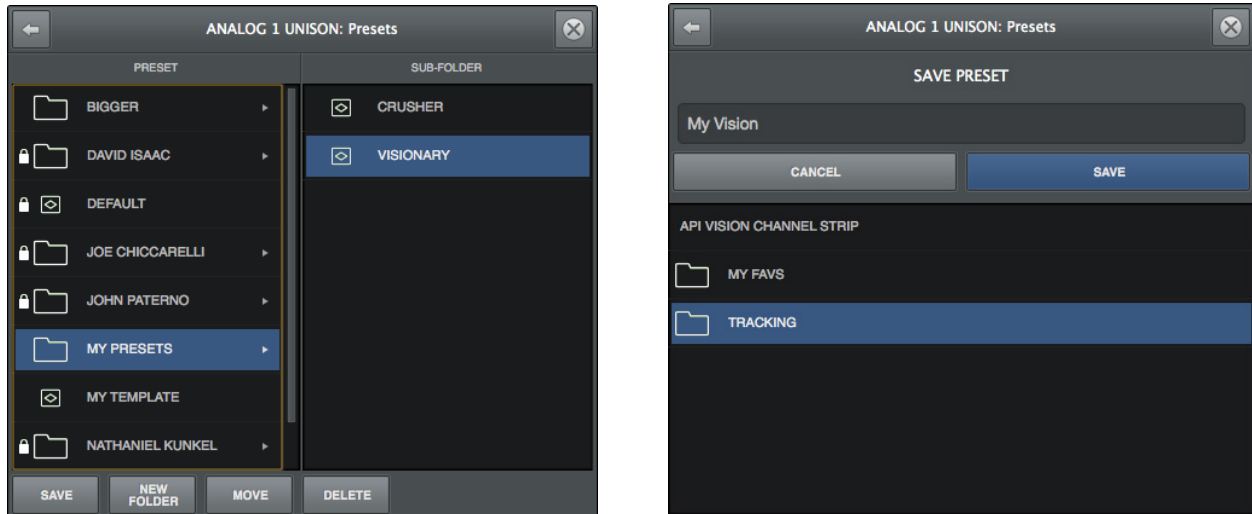

The Presets Manager popovers

Presets Overview

A preset is a complete collection of settings for an individual plug-in that is saved as a disk file so the settings can be subsequently recalled. Presets are typically used to save and recall favorite plug-in settings. Thousands of factory presets are installed with the software, or they can be user-created.

Preset files have the “.fxp” suffix (file suffixes are only visible in the OS X Finder when the “Show all filename extensions” option is checked in the OS X Finder’s Preferences window).

Factory Presets

Factory presets are plug-in settings created by the plug-in developers for typical use case scenarios. All UAD plug-ins developed by Universal Audio include a batch of factory presets. They can be used as-is, or modified as desired.

All factory presets, and factory preset folders, are read-only. They cannot be overwritten, renamed, deleted, or moved. However, factory presets/folders can be saved under a different name or in a different file location.

Factory presets/folders are indicated by a lock icon at the left of a preset or folder icon. User presets/folders do not have the icon.

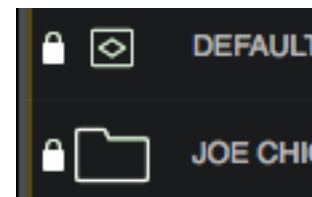

Factory preset & folder icons (indicated by lock) as they appear in the Presets Manager

Note: Not all UA Direct Developer (3rd-party) plug-ins include factory presets.

Presets Folder Location

All factory and user preset files for UAD plug-ins are stored at the following location within the Mac OS X file system:

- /Library/Application Support/Universal Audio/Presets

Tip: User presets and folders can be organized via the OS X Finder. File locations in the Finder are reflected within the Presets Manager.

Plug-In's Presets Folder

Inside the Presets folder above are folders named with the title of each UAD plug-in. Each of these folders contain all factory and user presets for that particular plug-in. This is the *plug-in's presets folder*. The contents of this folder is displayed in the PRESET column within the Presets Manager.

Note: User presets can only be saved to the plug-in's presets folder.

Presets Sub-Folders

Each plug-in's presets folder can contain one level of sub-folders for additional preset organization capability. The contents of sub-folders (if any) are displayed in the SUB-FOLDER column when a folder in the PRESET column is selected.

Channel Strip Presets

A Channel Strip preset is a complete collection of plug-ins within a single channel, and all parameter settings within those plug-ins, that is saved as a disk file so the channel strip preset can be subsequently recalled into the same or a different channel.

Tip: To activate Channel Strip view, click the Channel Strip icon in the Edit Window. Channel Strip mode is active when the switch is orange colored.



Channel strip preset files have the “.uadchannel” suffix (file suffixes are only visible in the OS X Finder when the “Show all filename extensions” option is checked in the OS X Finder's Preferences window).

Channel Strip Presets Folder

All Channel Strip presets reside in the *Channel Strips presets folder*. The contents of this folder is displayed in the PRESET column within the Presets Manager.

Note: Channel Strip presets can only be saved to the Channel Strip presets folder.

Channel Strip Presets Folder Location

All Channel Strip files are stored at the following location within the Mac OS X file system:

- /Library/Application Support/Universal Audio/Presets/Channel Strip

Tip: User Channel Strip presets and folders can be organized via the OS X Finder. File locations in the Finder are reflected within the Presets Manager.

Channel Strip Presets Sub-Folders

The Channel Strip presets folder can contain one level of sub-folders for additional channel strip preset organization capability. The contents of sub-folders (if any) is displayed in the SUB-FOLDER column when a folder in the CHANNEL PRESET column is selected.

Presets Manager Popover

The Presets Manager popover window contains the PRESET and SUB-FOLDER columns and several function switches. The columns and switches are used to navigate and manage the preset files.

Tip: Plug-in settings are loaded instantly as they are selected in the columns.

Refer to the illustration below for descriptions in this section.



The Presets Manager popover

PRESET Column

All items within the plug-in's preset folder are displayed in the PRESET column.

Click any preset in the PRESET column to instantly load it, or click a sub-folder (if any) to display presets within the sub-folder in the SUB-FOLDER column.

If more presets or folders reside in the column than are currently within view, a scroll bar appears.

SUB-FOLDER Column

If the PRESET column contains one or more folders, selecting the folder will display its contents in the SUB-FOLDER column. Click any preset in the SUB-FOLDER column to instantly load it.

If more presets reside in the column than are currently within view, a scroll bar appears.

Presets Manager Function Buttons

The Presets Manager contains switches to name, save, and perform other file management tasks. Click a switch to perform the operation on the currently selected preset or sub-folder.

Save – Saves the current modified preset file in place. If the preset was not previously saved (if the file doesn't exist), the Save window appears.

New Folder – Creates a new sub-folder. Sub-folders appear in the left column of the Presets Manager.

Move – Opens the Save window where the selected preset can be moved to a different location within the presets folder, with the option to rename the preset.

Delete – Deletes the selected preset file from disk and removes it from the presets list. A confirmation dialog appears before the file is deleted.

Save Preset Popover

The Save Preset popover window is where presets and sub-folders can be named and moved. It appears when the Save or Move switches within the Presets Manager window are clicked.

Refer to the illustration below for descriptions in this section.

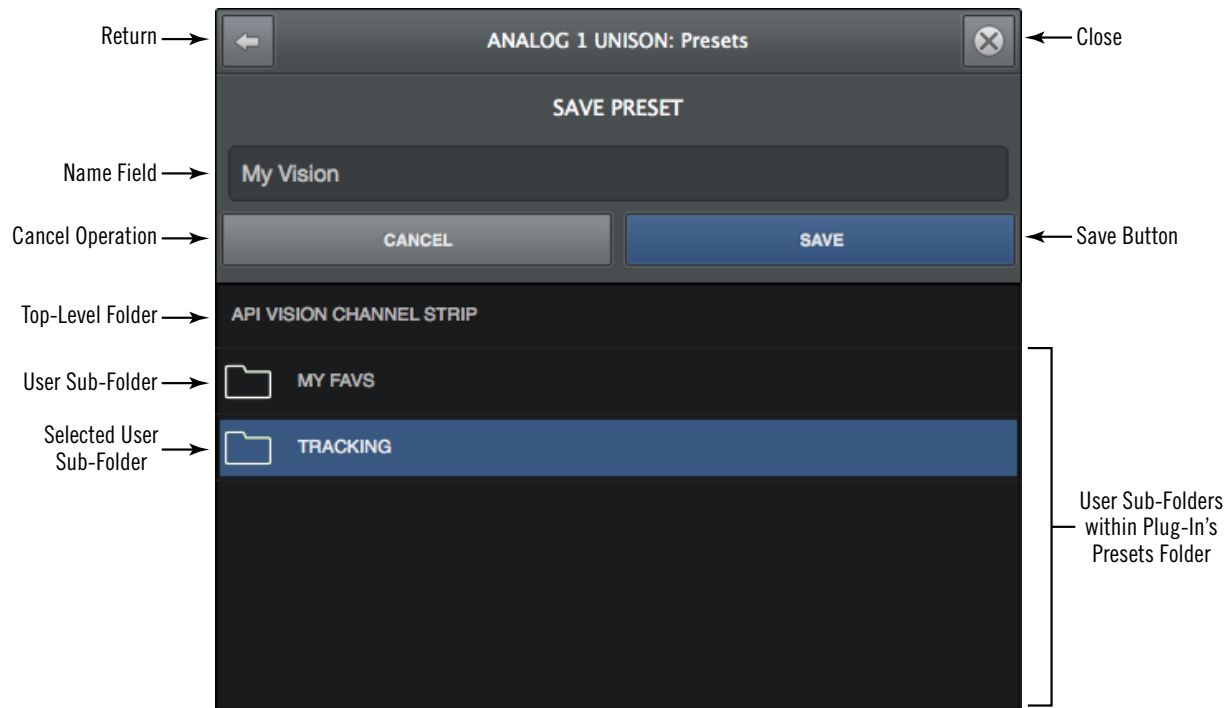

The Save Preset popover

Save Preset Popover Functions

Return – Returns to the main Presets Manager popover.

Close – Exits the Preset Manager and returns to the Plug-In Editor window.

Name Field – When creating a new preset or sub-folder, enter a unique name here.

Cancel – Cancels the operation and returns to the main Presets Manager popover.

Save – Creates the disk file or sub-folder.

Chapter 6: Console Settings

Console Settings Overview

Global parameters for Apollo and Console are configured in Console Settings. All Console Settings are detailed in this chapter.

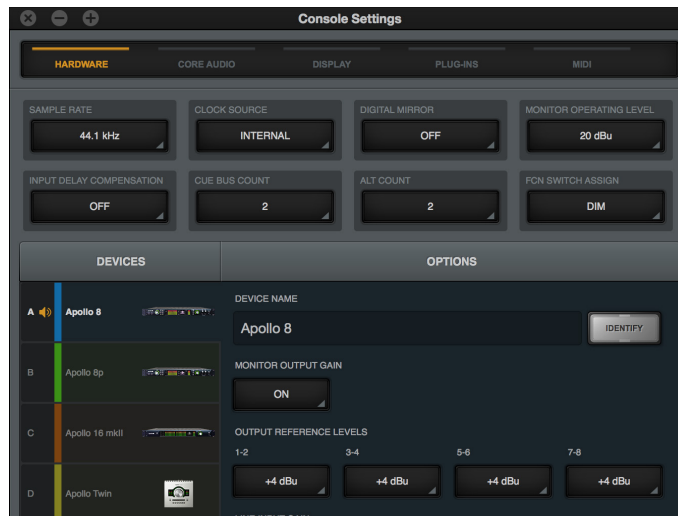

The Hardware panel within the Console Settings window

Console Settings Window

Console Settings are within the Console Settings window. The Console settings window is available from within the Console application.

The Console Settings window can be opened using any of these methods:

- Choose View>Settings from the [Application Menus](#)
- Choose Console Settings under the UA icon drop menu in the Mac OS X Menu Bar

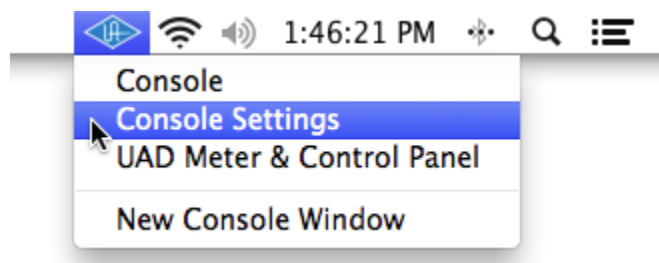

Accessing Console Settings from the Mac OS X Menu Bar

- Click the SETTINGS switch at the bottom of the [Meter Bridge](#)
- Use the “command+comma” keyboard shortcut



Settings switch in View Columns

Console Settings Panels

Controls within the Console Settings window are arranged according to related functionality. Each set of related settings are contained within a single panel. Five panels are available in the Console Settings window:

Hardware – Settings related to Apollo hardware device setup

Core Audio – Settings related to Flex Driver and custom driver I/O mapping

Display – Settings related to how and what items are displayed in Console

Plug-Ins – Settings related to UAD plug-ins used within Console

MIDI – Settings for setting up MIDI control of Tap Tempo within Console

Accessing Settings Panels

Each of the five Console Settings panels is accessed by clicking the panel's name at the top of the Console Settings window. The panel is selected and displayed when its name is illuminated.

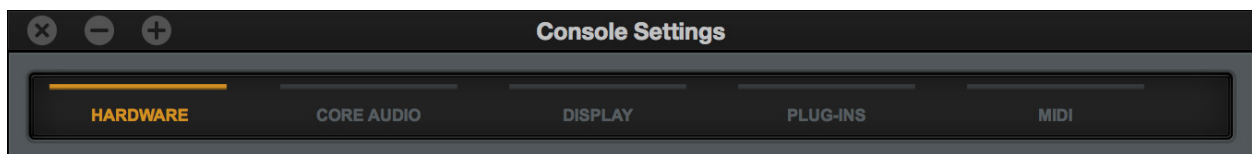

Panel names at the top of the Console Settings window with the HARDWARE panel selected

Changing Settings

Unless otherwise noted, all values within the Console settings window are changed by either choosing a different value from a drop menu, or entering a new values directly.

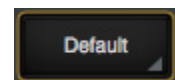

Typical disclosure triangle

Drop Menus – Values with drop menus are indicated by a disclosure triangle at the lower right of the value field. To change these settings, click the item and choose a different value from its drop menu.

Direct Entry – Values with direct text or numerical entry have a lighter gray background and do not have a disclosure triangle at the lower right of the value field. To change these settings, click the field and type a new value with the keyboard, then type the Return/Enter key.

Available Settings

The parameters that are displayed in the Console Settings window can vary depending on the particular Apollo hardware model(s) that are currently connected to the system.

Only settings that apply to the currently connected hardware are displayed. Any settings that are unique to a particular hardware model are noted in the descriptions.

Hardware Settings Panel

The Hardware panel is where Apollo's system-level audio interface I/O settings such as sample rate, clock source, and output reference levels are configured. These settings are used by DAW applications when they are configured to use Apollo as the audio interface. Even when Console is not open, these settings are stored by the Apollo drivers for use by other host applications.

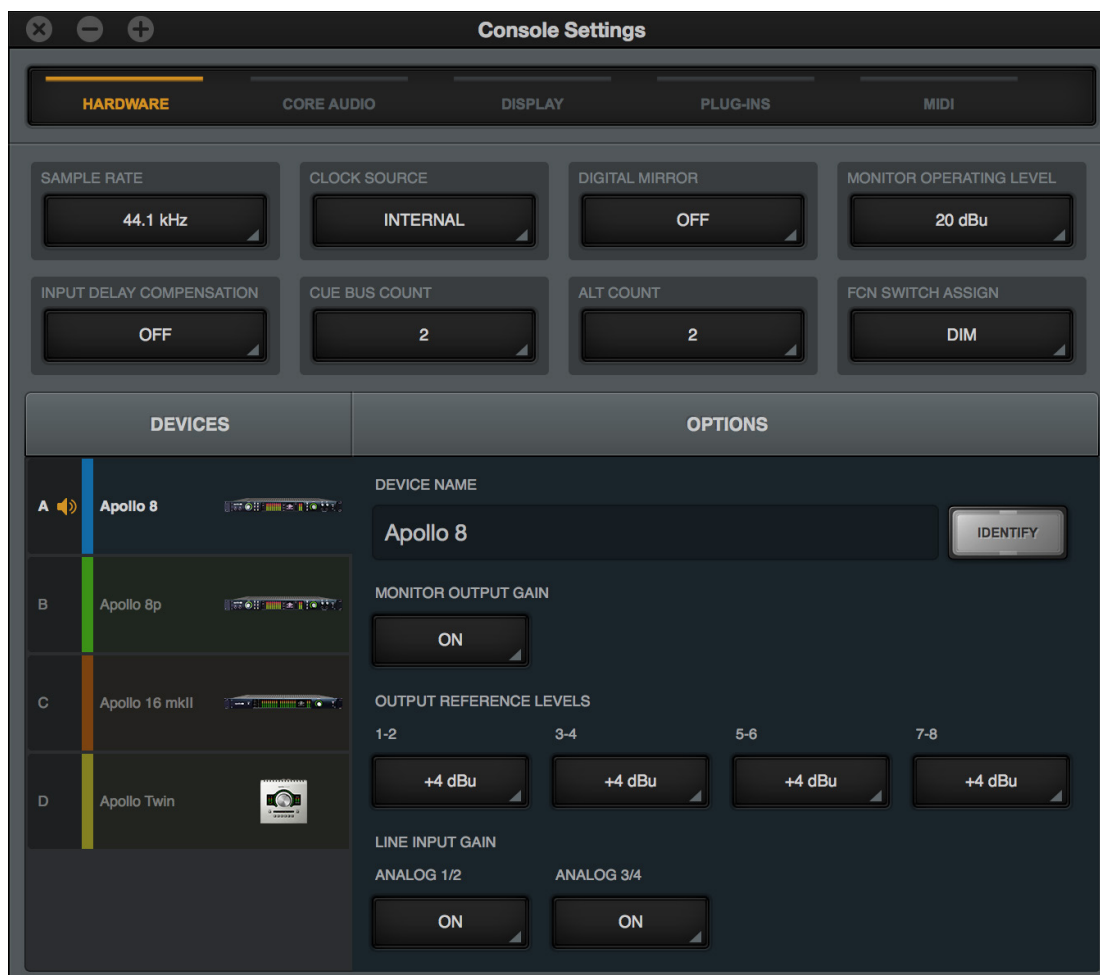

The Hardware panel as displayed with multiple Apollo devices

Sample Rate & Clock Settings

Behavior and control of these two settings depend on the operating environment:

Without a DAW – Sample Rate and Clock Source settings define the active sample rate and clock source for Apollo when a DAW is not used (when Console is the only host application).

With a DAW – These settings are usually changed within the DAW application's audio preferences.

Tip: These settings can also be viewed and changed via Console's [Info Bar](#).

Sample Rate

This setting defines the sample rate that is used for Apollo A/D and D/A conversion and UAD Powered Plug-Ins processing. When using UAD Powered Plug-Ins, higher sample rates require more UAD DSP resources.

Important: When the Clock Source parameter is set to use any external clock source, the sample rate must be manually set to match the sample rate of the external clock.

Note (Apollo Twin and Apollo 8p): If the current digital input setting is S/PDIF and the sample rate is changed to a rate higher than 96 kHz, the clock source is changed to Internal and the S/PDIF inputs are no longer unavailable.

Clock Source

This setting determines the master clock source for A/D and D/A conversion. The available values are:

Apollo, Apollo 8, Apollo 8p – Internal clock or external clock from S/PDIF, ADAT, or Word Clock

Apollo 16 – Internal clock or external clock from AES/EBU or Word Clock

Apollo Twin – Internal clock or external clock from S/PDIF or ADAT

If the Clock Source setting is not set to Internal and the external clock signal is not detected, then the text in the Clock Source display is RED (if this occurs, verify connections and external clock device settings).

Note: Only one device in a system can be the master clock. This setting must match the host DAW setting or audio glitches and/or distortion could occur.

Digital Mirror

This setting configures the S/PDIF outputs (Apollo, Apollo 8, Apollo 8p) or AES/EBU outputs (Apollo 16) to mirror the Monitor 1 & 2 outputs. This feature is typically used when connecting to the stereo inputs of other devices with digital inputs such as a speaker system, stereo recorder, or external D/A converter.

When Mirror mode is ON, the Monitor Level knob controls both the digital output level and the analog monitor output level (these digital outputs are post-fader when mirrored).

This setting is unavailable with Apollo Twin, which does not feature digital outputs.

Note: When set to ON, any DAW outputs and/or Console aux outputs that are routed to these digital ports will not be heard, because the digital ports are switched to output the monitor bus instead.

Monitor Operating Level

This menu switches the operating level of the monitor outputs. Available selections are 20 dBu and 14 dBu.

Note: This setting is unavailable with the original (silver) Apollo, which does not feature an adjustable operating level.

Input Delay Compensation

Input Delay Compensation maintains phase alignment across Console's analog and digital inputs when certain UAD plug-ins are used. See [“Input Delay Compensation in Console” on page 178](#) for a complete explanation of this feature.

When enabling Input Delay Compensation, it's usually best to start with the Short value (100 samples) to minimize latency. The default value is Medium.

Input Delay Compensation Values	
Setting Name	Extra Delay (samples)
Off	0
Short	100
Medium	200
Long	1000

Note: Changes to this setting do not take effect until the DAW is quit.

Input Delay Compensation Exceeded Dialog

A dialog will appear in Console if the compensation amount is exceeded on a channel. If this occurs, either increase the IDC value or reduce upsampled plug-ins usage on the channel to maintain phase alignment.

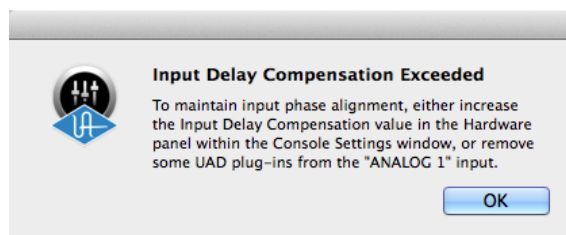

Tip: Input Delay Compensation and phase alignment is only important when multiple Console inputs are used for a single source (such as a drum kit using multiple microphones). For the lowest possible latency if not using multiple inputs for a single source, turn Input Delay Compensation OFF.

Cue Bus Count

The number of active cue mix buses is changed with this setting. Increasing the Cue Bus Count increases the number of cue mix buses (and associated cue sends and returns) available within Console and the DAW.

Between two and four cue buses can be set. The default value is two with Apollo and four with Apollo 16. This setting is unavailable with Apollo Twin, which always features two cue mix buses (HP and Line 3/4).

Note: Cue buses 3 and 4 are unavailable at sample rates of 176.4 kHz and 192 kHz.

ALT Count

This setting determines the number of ALT (alternate) monitor outputs that are available within Console. Between zero and two ALT outputs can be set. The default value is zero.

For an overview of this feature, see the [ALT Monitoring Overview](#).

***Important:** Increasing the ALT count overrides any other assignments using Line outputs 1, 2 (ALT count of 1) and Line outputs 1, 2, 3, 4 (ALT count of 2)*

FCN Switch Assign (Apollo 8, Apollo 8p)

Apollo 8 and Apollo 8p feature an assignable function (FCN) switch on the hardware front panel that can be configured to control one of three monitoring functions.

The function of the switch is configured with this menu. The available functions are:

ALT 2 – Selects the Alternate 2 monitor speakers. The monitor signals are routed to outputs 3 & 4 instead of the main monitor outputs, and the monitor level indicator ring is yellow instead of green when ALT 2 is active.

MONO – Sums the left and right channels of the stereo monitor mix into a monophonic signal. The monitor level indicator ring flashes when MONO is active.

DIM – Attenuates the signal level at the monitor outputs by the dB amount set in Console's Control Room strip. The monitor level indicator ring flashes when DIM is active.

NONE – The FCN switch is unassigned.

***Note:** When more than one Apollo interface is connected in a multi-unit configuration, the FCN switch is operable on the designated monitor unit only.*

Devices Column

This column lists all Apollo devices in the system. It has four primary functions:

1. Selects current unit to see device-specific options
2. Designates the monitor unit in multi-unit setups
3. Indicates which unit(s) are currently online
4. Adds devices for offline configuration

Select Device

Clicking a unit in the column reveals its device-specific settings in the [Options Column](#).

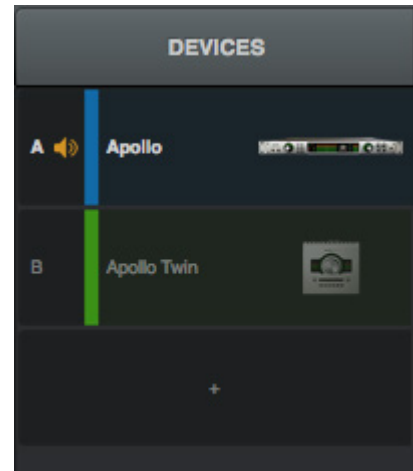

Device Letter

Each unit in the Devices list is designated with a sequential letter. These letters are used in the [Core Audio Panel](#) when multi-unit cascading to differentiate between Apollo devices. The device letters cannot be modified.

Device Color

Each unit in the Devices list is color coded for enhanced identification. These colors are used in the [Meter Bridge](#) and the [Core Audio Panel](#) when multi-unit cascading to differentiate between devices. The device colors cannot be modified.

Designate Monitor Unit

In multi-device configurations, the device at the top of the column is the designated monitor (master) unit. The monitor unit is indicated by a speaker icon between the device letter and the device name. To change the monitor unit, drag a unit to the top of the device column.

For related details, see [Chapter 10: Multi-Unit Cascading](#).

Note: *This operation reconfigures the system. There may be a delay before the operation is completed.*

Add Device

Unit(s) can be manually added for offline configuration by clicking the “+” switch (below the devices in the column) to present the Add Device menu.

Note: *When a device is properly connected and powered, it is automatically detected and added to the device list.*

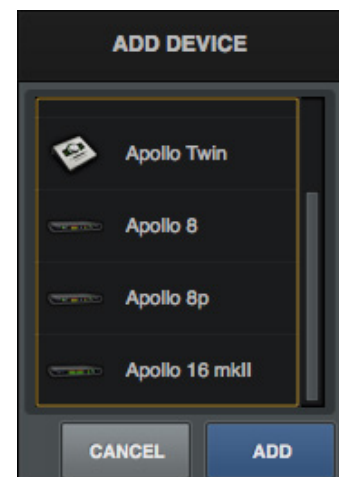

Options Column

Selecting a unit in the Devices column reveals its device-specific settings in the Options column. A device is currently selected when its text is not dim.

Note: Settings in the Options Column apply only to the specific unit currently selected in the Devices Column.

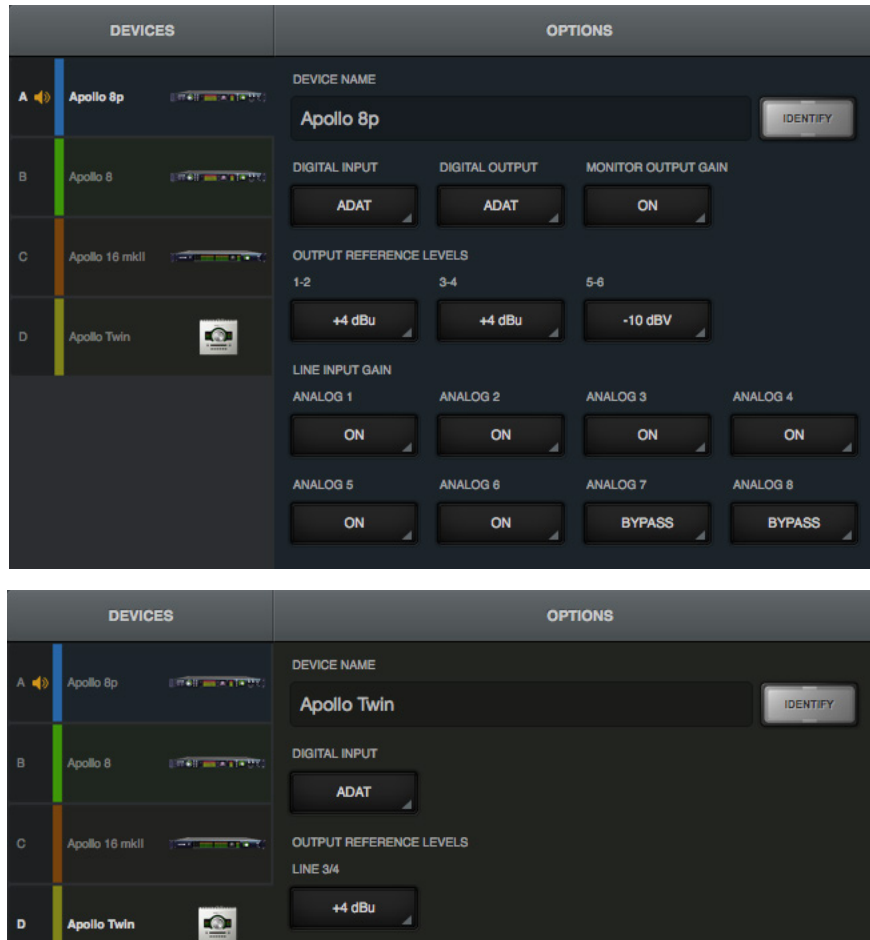

Device options as displayed for Apollo 8p (top) and Apollo Twin (bottom)

Device Name

Apollo's default device name can be changed. The device name is displayed in the "Connecting to Apollo" window that appears briefly during system connection, in the Core Audio panel settings, and optionally in the Meter Bridge.

Note: Text in this field cannot be modified when the device is offline.

Identify

Clicking the Identify switch will cause the currently selected unit's front panel LEDs to flash in a pattern. This feature is typically used with multi-unit systems to distinguish units when making I/O connections.

Note: *If the device is offline, this switch displays REMOVE instead.*

Remove

When a device is offline, it can be removed from the devices list. To remove an offline device, select the unit in the DEVICES column, then click the REMOVE switch in the OPTIONS column.

Note: *If an expander unit is powered down or disconnected from the system, the expander unit must be removed before the sample rate can be changed to 176.4 kHz or 192 kHz.*

Output Reference Levels

These drop menus set the reference level for the line outputs. The number of menus displayed depends on the currently connected Apollo hardware (for example, Apollo 16, which features more outputs, will display more output menus).

The line output reference levels can be set to -10 dBV or $+4$ dBu in adjacent pairs. The value is usually set to match the nominal input level of devices connected to these outputs (a setting of $+4$ dBu outputs a higher signal level than -10 dBV).

Note: *Input reference levels for the analog line inputs are set in Console's channel input strips.*

Digital Input (Apollo 8p, Apollo Twin)

This menu selects the digital input type (ADAT or S/PDIF) to be used by the TOSLINK optical connector and Console's digital input channels.

Apollo 8p and Apollo Twin supports S/PDIF digital input at sample rates up to 96 kHz. If the current setting is ADAT and the sample rate is higher than 96 kHz, when S/PDIF input is selected, the clock source is changed to Internal and the S/PDIF inputs are no longer unavailable.

Digital Output (Apollo 8p)

This menu selects the digital output type (ADAT or S/PDIF) to be used by the TOSLINK optical connector and Console's digital outputs channels.

Apollo 8p supports S/PDIF digital output at sample rates up to 96 kHz. If the current setting is ADAT and the sample rate is higher than 96 kHz, when S/PDIF input is selected, the clock source is changed to Internal and the S/PDIF outputs are no longer unavailable.

Monitor Output Gain (Apollo 8, Apollo 8p, Apollo 16 mkII)

Note: In multi-unit configurations, this setting is available for the designated monitor unit only.

By default, monitor output levels are continuously variable. However, the monitor outputs can be set to completely bypass the monitor level circuitry and operate at a fixed reference level.

This feature routes the signal directly from the D/A converters to the monitor outputs for the purest path when level control is not needed (for example, when connecting the monitor outputs to an external monitor controller). Two settings are available:

On – The monitor controls operate normally

Bypass – The monitor controls and associated circuitry are bypassed, and:

- The Monitor Level cannot be adjusted
- The Monitor Level Indicator ring is solid green
- The Monitor Level Value display changes to “BYP”
- ALT monitoring and assignable FCN switch features are unavailable
- Signals at the Monitor Outputs are output at line level (without attenuation)

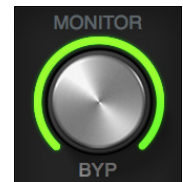

Line Input Gain (Apollo 8, Apollo 8p)

By default, line inputs on preamp channels are routed through the channel's preamp so the line input level can be adjusted with the Gain knob. However, preamp channel line inputs can be individually set to completely bypass the channel's preamp circuitry and instead operate at a fixed reference level.

This feature routes the preamp channel's line input signal directly into the D/A converter for the purest path when additional gain is not needed (for example, when connecting external mic preamps to preamp channel line inputs). Two settings are available:

On – The line input is routed through the channel's preamp

Bypass – The preamp and associated circuitry are bypassed, and:

- The Preamp Gain Indicator ring for the channel is solid green
- If a Unison plug-in is in the channel's dedicated Unison insert, the Unison plug-in is bypassed

Core Audio Panel

Flex Driver

The Core Audio panel is where Apollo's *Flex Driver* features are managed. For an overview of Flex Driver features, see [“Flex Driver Overview” on page 40](#).

Core Audio Columns

In addition to the switches at the top of the panel, two columns are displayed. The INPUTS column on the left displays all available Apollo inputs. The OUTPUTS column on the right displays all available Apollo outputs.

Core Audio Rows

Each row in the panel represents a single Apollo audio channel. The currently assigned input and output route for each channel is displayed within a single row. By clicking any assign switch, a different route can be mapped to the channel.

Tip: To view more channels simultaneously, increase the vertical size of the Console Settings window.

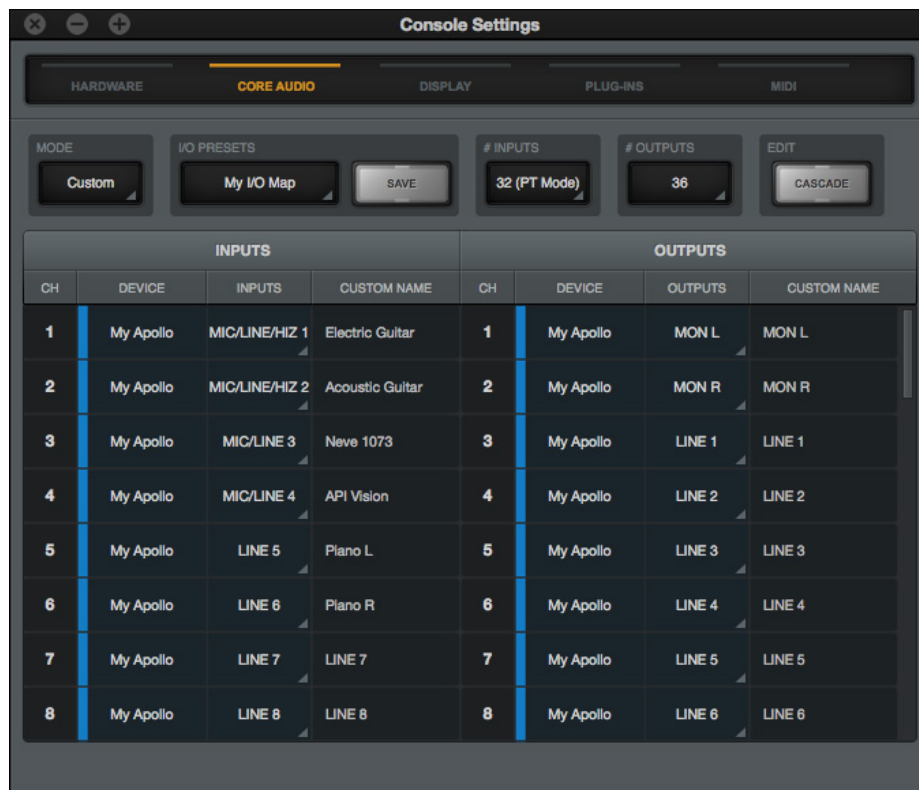

The Core Audio Panel

Core Audio Panel Elements

Refer to the diagram below for descriptions in this section.

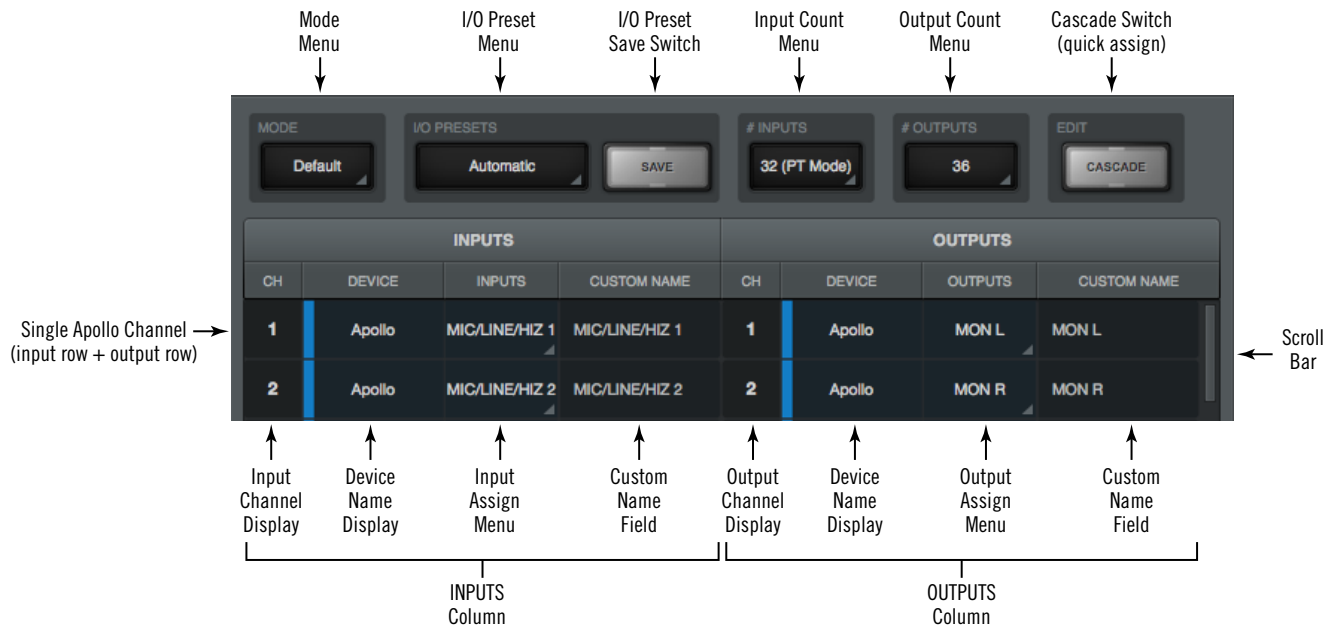

The main Core Audio panel elements

Mode Menu

This menu provides a quick way to return to Apollo’s default Core Audio driver settings. When any settings within the Core Audio panel are not the default value, this menu displays “Custom.”

To return to the factory default settings, choose “Default” from the MODE drop menu.

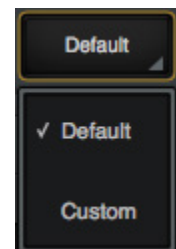

Mode menu

Important: Any customized settings within the Core Audio panel will be lost when the mode is changed to Default unless the custom settings are saved first via the I/O Preset controls.

If the mode is switched from Default to Custom, the I/O Preset Display shows “(Untitled)” indicating the current settings have not yet been saved.

I/O Presets Overview

The I/O presets controls provide methods for managing complete Core Audio panel configurations as I/O preset files. When an I/O preset file is saved, the current Core Audio panel configuration is written to disk.

When an I/O preset file is subsequently reloaded, the Core Audio panel is returned to the exact same routing state, regardless of any changes to Core Audio settings that were made in the interim.

I/O Preset Files Location

I/O preset files are saved to, and loaded from, the user's home folder at:

- ~/Documents/Universal Audio/IOPresets/

Note: I/O preset files must reside in the default location to appear in the Route Presets popover window within Console.

Session Files Suffix

I/O preset files have the “.uadio” suffix. The suffix is added to session files automatically when saving to disk; however, the suffix is not displayed in the file save dialog (the suffix should not be manually typed when saving a I/O preset file).

Note: Without the .uadio suffix, the session files will not be visible in the load preset window.

Factory I/O Presets

A variety of I/O presets are pre-installed with the software. The factory I/O presets are provided for backwards compatibility with Apollo sessions created with Console v1.

To take advantage of all of the new features in Flex Driver and Console 2.0, the new “Default” mode “Custom” modes may prove more appropriate in order to take advantage of the new features (such as limiting the driver to 32 I/O channels, arranging the I/O in any desired order, using up to 4 CUE mixes, or using up to 8 Virtual I/O channels). Note if older DAW sessions were saved using previous versions of Apollo's driver and the new Flex Driver features are used upon reload, the Input/Output configuration tools in the DAW software may need to be modified.

I/O Presets Menu

The currently loaded I/O preset name is displayed on top of the menu switch, as shown at right. If the I/O preset has not yet been saved, then “(Untitled)” appears in the display.

If a loaded I/O preset has been modified since it was saved, the I/O preset name is displayed in *italics*, as shown at right.

Clicking the I/O Presets display opens the [I/O Presets Popover](#), where various I/O preset functions can be performed.



Save Switch

This switch saves the current state of the Core Audio panel to disk as an I/O preset file. If the I/O preset already exists, the existing I/O preset file is overwritten with the current settings. If the I/O preset has never been saved, the Save I/O preset window (shown at right) appears so the preset can be named.

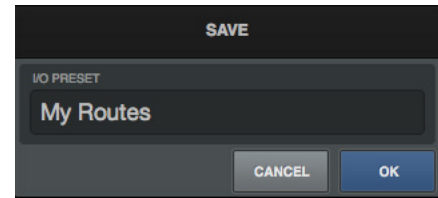

Save I/O preset window

Important: Settings will not be properly saved if the “/” (forward slash) or “?” (question mark) characters are in the filename. Avoid these and other special characters when saving I/O preset files.

I/O Presets Popover

The I/O Presets popover window is where various functions can be performed on I/O preset files. To open the I/O Presets window, click the I/O Presets Menu.

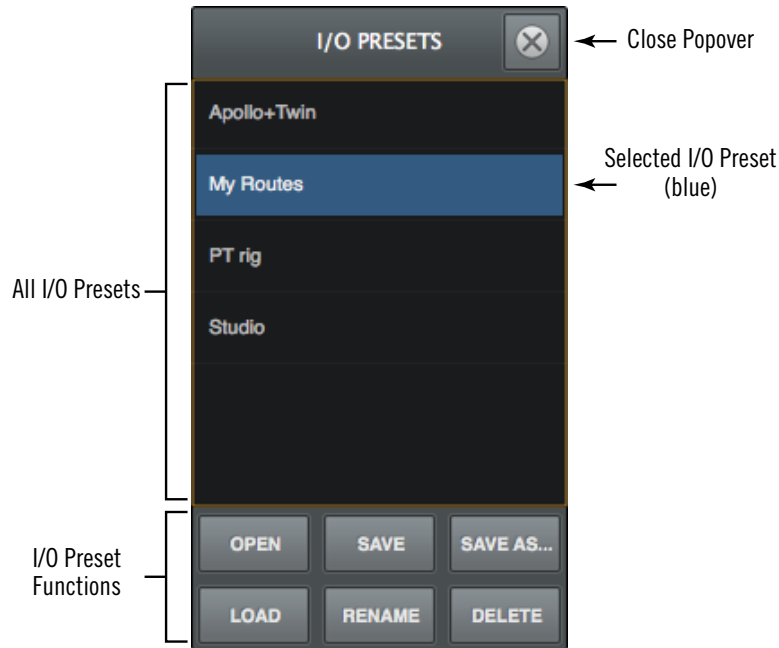

The I/O Presets popover

All existing I/O preset files at the [I/O Preset Files Location](#) are displayed in a list within the I/O Presets window. Available functions at the bottom of the window can be performed on the selected I/O preset (a preset is selected when it is highlighted in blue).

I/O Presets Functions

The following I/O preset functions are available:

Open – Opens the operating system’s standard “Open File” dialog for loading existing I/O preset files from disk.

Save – Saves the current modified I/O preset file in place. If the preset was not previously saved (if the file doesn’t exist), the Save window appears so it can be named.

Save As – Opens the Save window so the current settings can be named and saved to disk as a new I/O preset file.

Load – Loads the I/O preset that is currently selected within the I/O Presets window (a preset is selected when highlighted in blue).

Tip: An I/O preset can also be loaded by double-clicking the preset or typing Return (or Enter) when the preset is selected.

Channel Count Menus

The Channel Count menus (one each for number of inputs and number of outputs) are used to change the number of Apollo I/O channels used by Core Audio.

By default, the total number of available input and output channels, for all detected Apollo devices, are displayed.

The primary reason to change the channel counts is to accommodate the 32 I/O channels available within Pro Tools. When 32 channels are selected for Apollo I/O (PT Mode), any Apollo I/O can still be used by virtually remapping the I/O so the desired channels fit within the available channel count.

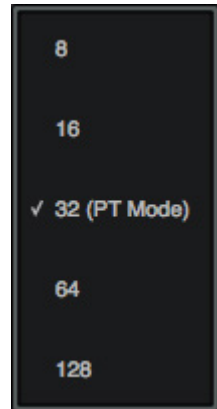

Channel Count menu

Important: These menus change the driver I/O complement. Quit all DAW applications before changing the Channel Count settings.

Inputs – The number of active Apollo input channels used by Core Audio is displayed here. Click the display to select a different input channel count from the menu.

Outputs – The number of active Apollo output channels used by Core Audio is displayed here. Click the display to select a different output channel count from the menu.

Note: Each Core Audio stream uses host computer CPU resources. To maximize CPU performance, do not set the channel counts higher than the number of channels actually needed.

Device Name Display

The [Device Name](#) of the Apollo device is displayed in the INPUT and OUTPUT columns so each Apollo unit can be readily identified in multi-unit setups. Each device is color-coded for easier identification.

Cascade Switch

The Cascade switch is used to quickly assign continuous I/O channels if routings have been changed from default values.

Note: Cascade doesn't do anything when the [Mode Menu](#) displays "Default" because all channels are already continuous in default mode.

When Cascade is clicked, the Cascade switch and all channel numbers are illuminated. Click+hold any channel number, then swipe down adjacent channel numbers to quickly assign the channel(s) to the next available channel(s) in the device.

Tip: Increase the vertical size the Console Settings window to view more channels simultaneously, so more channels can be swiped.

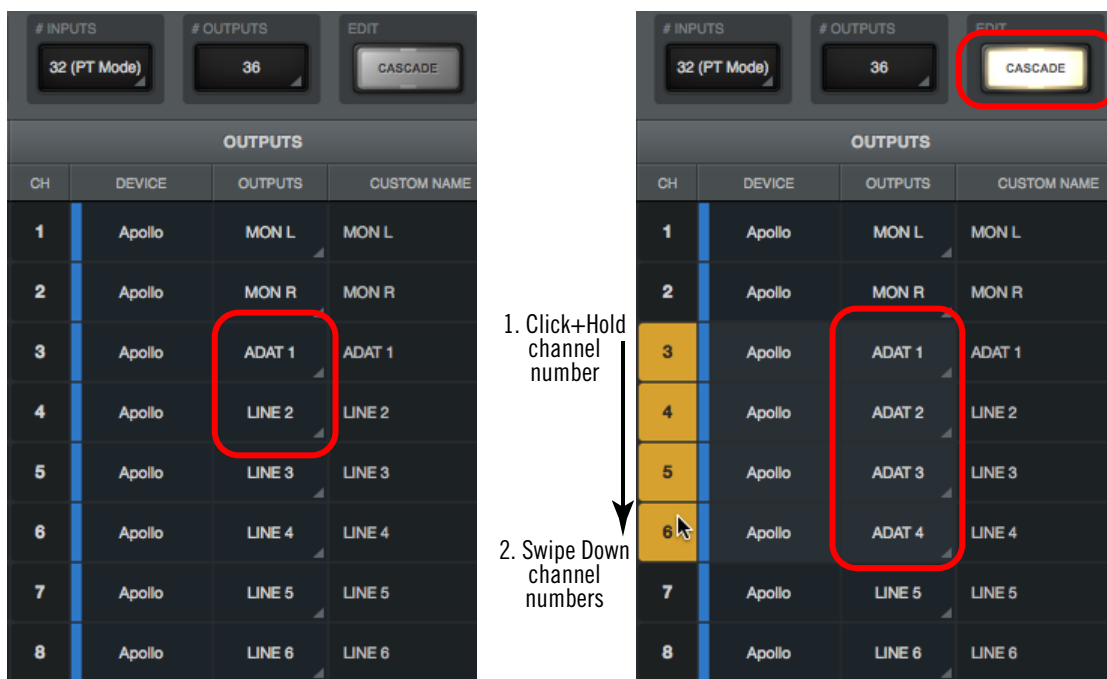

Using Cascade to quickly assign multiple channels. In this example, ADAT 1 was previously assigned to LINE 1 (left screenshot). With Cascade engaged (right screenshot), swiping the ADAT output across the LINE outputs quickly reassigns the LINE outputs to ADAT outputs.

Assign Switches

Each input and output channel has an assign switch. The assign switches are indicated by disclosure triangles at the lower right of each switch. The currently assigned route is displayed in the switch.

Default input and output routes can be remapped using the assign switches. Clicking an assign switch opens the [Route Assign Popover](#) for mapping a different route to the channel.



Two assign switches

Custom Name Field

Each Core Audio channel includes a name. This name is displayed wherever Core Audio channel names are shown, such as I/O channel assignments within a DAW and the Audio MIDI Setup application included with Mac OS X.

Apollo's Core Audio channel names can be customized by simply entering a different name in the Custom Name field. All custom name changes are instantly reflected in the application that displays channel names.

To return to the default driver name:

1. Click a customized name in the CUSTOM NAME column. The custom name text is highlighted.
2. Press the Delete key to remove the customized text from the field.
3. Press Return/Enter.

INPUTS	CUSTOM NAME
MIC/LINE/HIZ 1	Electric Guitar
MIC/LINE/HIZ 2	Acoustic Guitar
MIC/LINE 3	Neve 1073
MIC/LINE 4	API Vision

Example of customized driver names

Route Assign Popover

The Route Assign popover window is where Apollo I/O routes can be virtually re-mapped. To open the Route Assign window, click any assign switch.

Important: Custom driver I/O routing changes the driver I/O complement. Quit all audio applications before changing driver I/O assignments.

Refer to the diagram below for descriptions in this section.

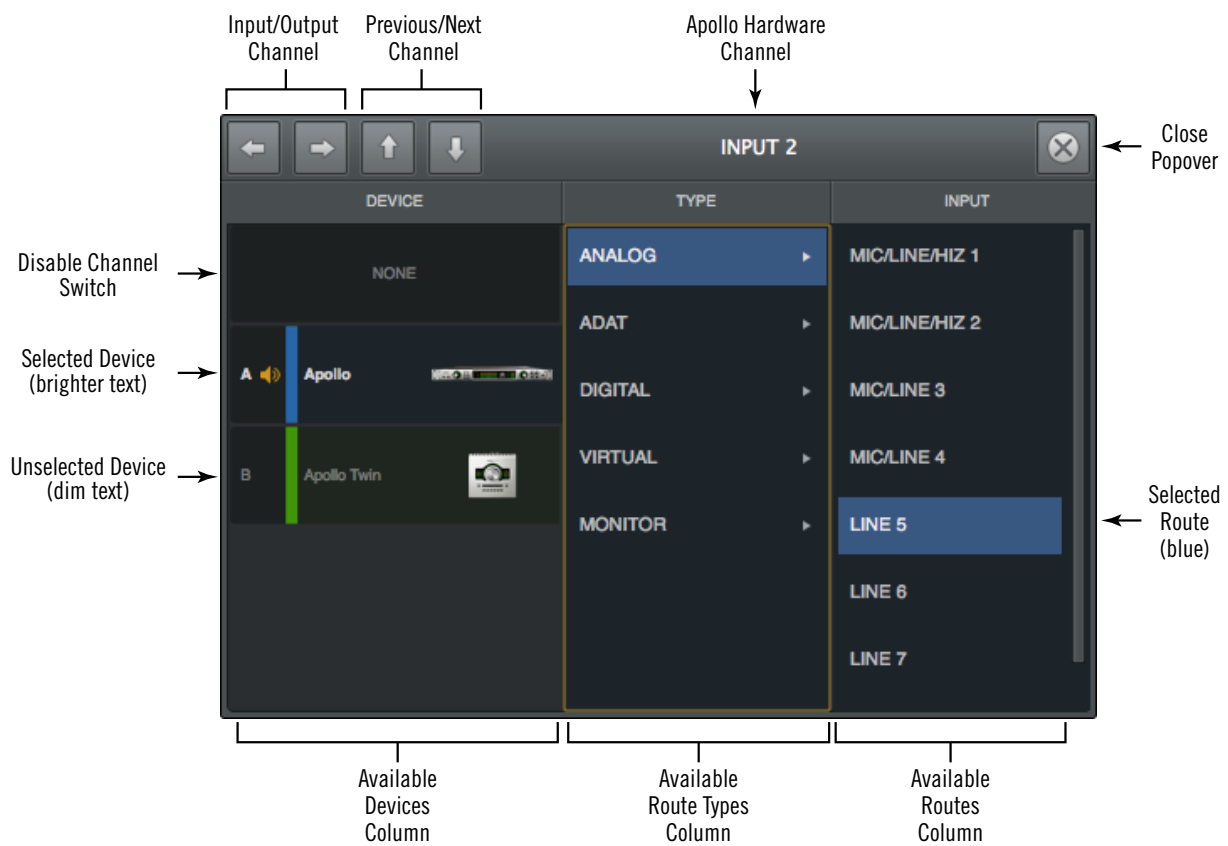

The Route Assign popover

Window Title Bar

Navigation Switches

Input/Output Channel

Switches the window to display the input or output of the same Apollo channel.

Previous/Next Channel

Switches the window to display the previous or next Apollo channel.

***Tip:** The popover moves from channel to channel with these switches. To prevent the popover from moving when these switches are used, drag the window to any location other than its default position.*

Apollo Hardware Channel

The name of the Apollo hardware channel that is being re-assigned is displayed at the top of the window.

Route Assign Columns

The Device, Inputs, and Outputs columns are displayed in the Route Assign window.

Apollo Device

The DEVICE column on the left displays all detected Apollo devices and the NONE switch. Click a device to select it for channel assignments in the other two columns. Click NONE to remove all I/O assignments from the channel.

Channel Type

The TYPE column in the middle displays all available channel types for the selected Apollo device. Click a channel type to select it and display all channels available for assignment in the INPUT/OUTPUT column.

Available Routes

The column on the right displays all available routes for the selected channel type. Click an available route to assign the input or output. The assigned route is highlighted in blue.

***Note:** If an output is gray in the output column and cannot be selected, the output is already in use by an input channel (Flex Route), cue output, or ALT output.*

Display Panel

Various Console display options are set within the Display panel.

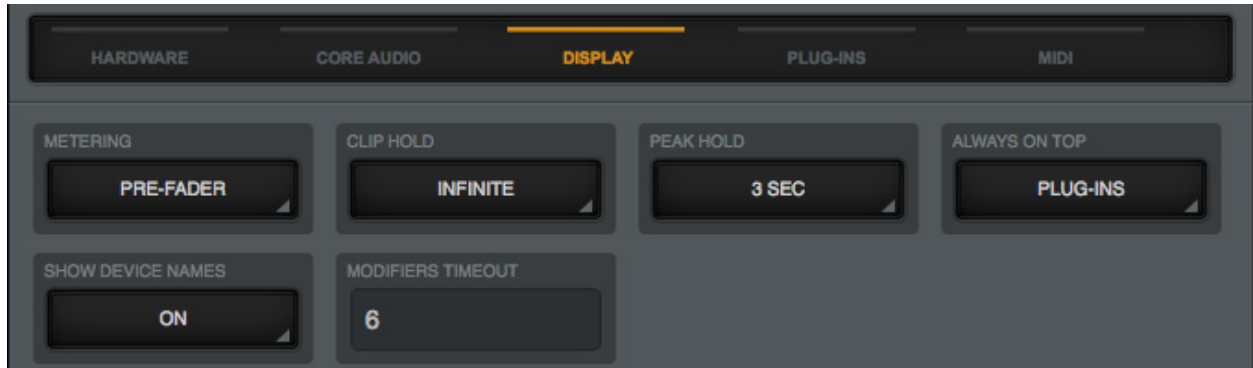

The Display panel

Metering

Pre-Fader

When set to Pre-Fader, an input's Channel Meter indicates the level at the Apollo input, regardless of the Channel Fader setting. With this setting, changing the fader level will not change the Channel Meter.

Post-Fader

When set to Post-Fader, changing an input's Channel Fader will change the Channel Meter.

Note: *The Metering Menu affects the Channel Meters of Console's channel inputs only. It does not affect the Aux Meters or the Monitor Meters.*

Clip/Peak Hold

Tip: *The Clip and Peak indicators can be cleared at any time with the [Clear Clips](#) button.*

Clip Hold Time

This drop menu sets the duration that the red signal clip indicators in the input, send, and monitor meters are displayed before turning off. The available values are None, 1 second, 3 seconds (default), 5 seconds, 10 seconds, or Infinite.

Peak Hold Time

This drop menu sets the duration that the signal peak indicators in the input and send meters are displayed before turning off. The available values are None, 1 second, 3 seconds (default), 5 seconds, and 10 seconds.

Always On Top

When set to NONE (the default value), a UAD plug-in editor window can be covered by the Console window when Console is the foreground application.

When set to PLUG-INS, UAD plug-in editor windows always float on top of the Console and Console Settings windows (when Console is the foreground application), so they can always be seen and adjusted.

Note: This setting only affects UAD plug-in window behavior within Console. It does not apply to UAD plug-ins when they are used in other host applications.

Show Device Names

When set to ON, Apollo's [Device Name](#) is displayed in the Meter Bridge.

This feature is intended primarily for use with multi-unit systems. When the Meter Bridge contains the inputs for more than one Apollo unit, this feature groups the input channels by device name for easier input identification.

Tip: This feature can also be accessed from the [Remove](#).



The Meter Bridge with Show Device Names OFF (left) and ON (right)

Modifiers Timeout

This option sets the period, in seconds, used for [Option Latch](#) operations.

Plug-Ins Panel

Various UAD plug-in options are set within the Display panel.

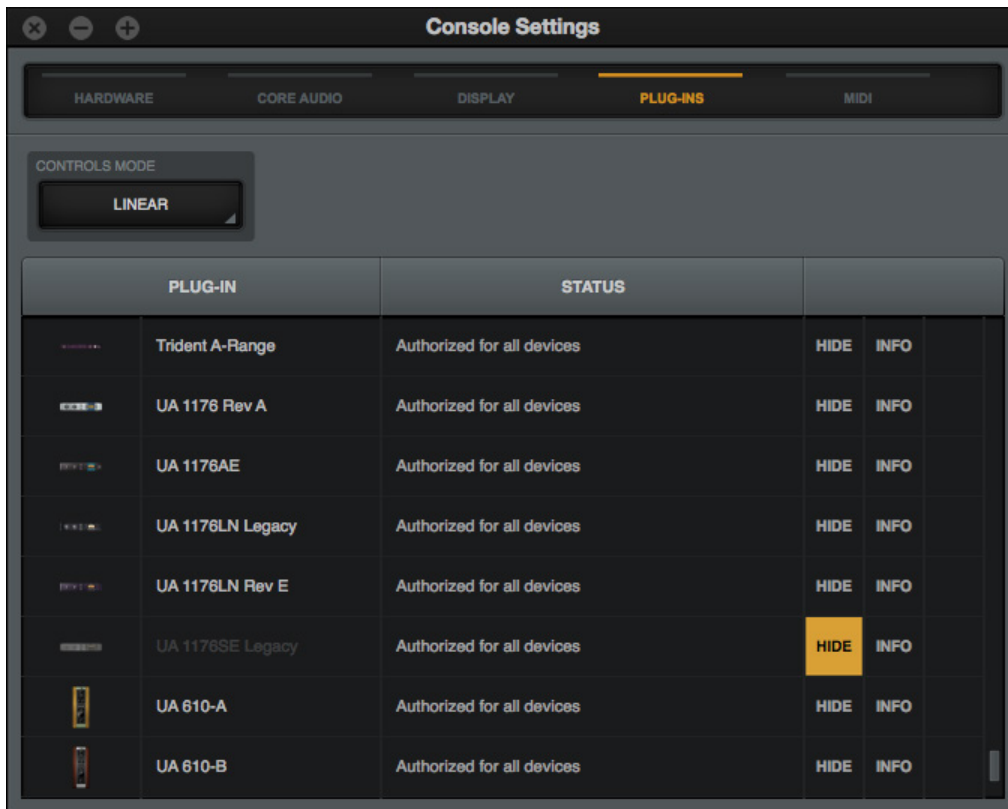

The Plug-Ins panel

Controls Mode

This setting determines how UAD plug-in parameter knobs respond to adjustment. Three control modes are offered: Circular, Relative Circular, and Linear. The behavior of each mode is described below.

Linear (slider) – In Linear mode, the knob is adjusted by dragging horizontally or vertically instead of by rotating. This behavior is similar to moving a physical fader.

Circular (jump) – In Circular mode, the software knobs behave similar to physical rotary knobs. Values are changed by clicking on the knob then rotating in a circular direction. When the edge of the knob is clicked, the parameter value jumps to the mouse position.

Relative Circular (grab) – Relative Circular mode operates similar to Circular mode, but the knob value does not jump to the mouse position when clicked. Instead, the knob value is modified relative to its original value.

In Relative Circular mode, click anywhere on the knob to make an adjustment originating at the original value (it's not necessary to click on the current knob position).

Tip: To increase resolution when in adjusting rotary controls in circular and relative circular modes, increase the radius of the mouse relative to the knob while dragging (move the mouse farther away from the knob while dragging in a circular motion).

Plug-In Column

All installed UAD plug-ins are displayed in the list in alphabetical order. Settings for each UAD plug-in are contained within its row. Vertically scroll the list to see plug-ins that are not currently in view.

Status Column

The authorization status and/or demo state of the plug-in is displayed here. The info shown mirrors the status shown in the Plug-Ins panel within the UAD Meter & Control Panel application.

Tip: To start a plug-in demo, click **START DEMO** in the [Plug-Ins panel](#) within the UAD Meter & Control Panel application, or in the UAD Toolbar at the bottom of each UAD plug-in editor.

Hide Column

These switches prevent UAD plug-ins from being visible from within Console. Click a plug-in's HIDE switch to toggle the state. The plug-in is hidden when HIDE is yellow and its title and icon are dim.

This function is used to restrict the availability of assignable plug-ins in plug-in lists. By default, all plug-ins are visible, even if they are unlicensed or the demo period is expired. By hiding plug-ins that are unlicensed or expired, only plug-ins that can process audio are exposed, which can be convenient for more rapid assignments.

Info Column

These switches open the plug-in's product pages at uaudio.com in the default web browser, providing a general overview the plug-in.

Tip: For detailed operational info for each plug-in, see the [UAD Plug-Ins Manual](#).

Buy Column

Adds an unlicensed plug-in to the shopping cart at the UA online store. Confirm you are logged in to the desired account at uaudio.com when purchasing the plug-in.

MIDI Panel

Console supports the ability to use MIDI to remotely set the tempo used for the Tempo Sync feature. The MIDI panel is where the specific MIDI controls are set.

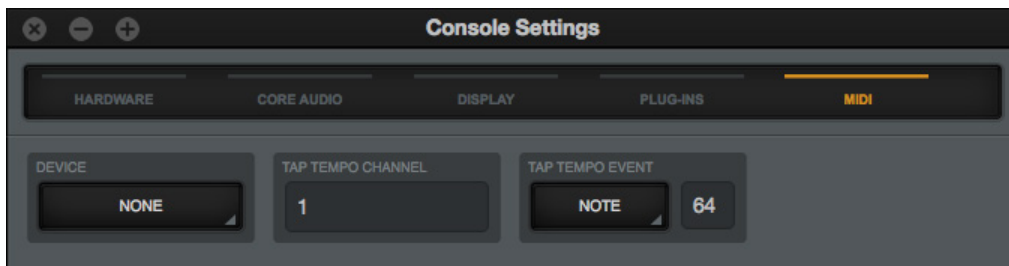

The MIDI panel

MIDI data is received by Console via the Mac OS X operating system. To verify and/or configure MIDI devices, use the Audio MIDI Setup application (included with OS X):

- /Applications/Utilities/Audio MIDI Setup.app>MIDI Window

MIDI Device

Sets the MIDI device to be used as the source for MIDI control. To set the device, click the MIDI DEVICE menu and choose a new device from the drop menu.

***Note:** Only devices configured in Audio MIDI Setup.app are available for selection in this menu.*

Tap Tempo Channel

Specifies the MIDI channel to be used for MIDI control. To set the channel, click the field and enter a numerical value between 1 – 16.

Tap Tempo Event

Console can receive note or controller data for MIDI control of Tap Tempo. These two settings define the MIDI data type and value used for MIDI control. For instructions, see [“Changing tempo via MIDI” on page 58](#).

MIDI Type Menu

Sets the MIDI data type to be used as the source for MIDI control. To set the data type, first click the drop menu then choose CONTROLLER or NOTE from the menu, or send the value from the MIDI controller.

MIDI Value Field

Sets the MIDI data value to be used as the source for MIDI control. To set the data value, first click the field then enter a numerical value between 0 – 127, or send the value from the MIDI controller.

MIDI Note Table

When NOTE is used as the MIDI type, the table below can be used as a reference for MIDI note values.

Note	Octave										
	-1	0	1	2	3	4	5	6	7	8	9
C	0	12	24	36	48	60	72	84	96	108	120
C#	1	13	25	37	49	61	73	85	97	109	121
D	2	14	26	38	50	62	74	86	98	110	122
D#	3	15	27	39	51	63	75	87	99	111	123
E	4	16	28	40	52	64	76	88	100	112	124
F	5	17	29	41	53	65	77	89	101	113	125
F#	6	18	30	42	54	66	78	90	102	114	126
G	7	19	31	43	55	67	79	91	103	115	127
G#	8	20	32	44	56	68	80	92	104	116	
A	9	21	33	45	57	69	81	93	105	117	
A#	10	22	34	46	58	70	82	94	106	118	
B	11	23	35	47	59	71	83	95	107	119	

MIDI note numbers by note name and octave

Chapter 7: Console Recall Plug-In

Console Recall Overview

Console Recall is a DAW plug-in supplied in VST, RTAS, AAX 64, and Audio Units formats. It is inserted and used within host DAWs as with any other plug-in.

Note: *The Console Recall plug-in is not required to use the Apollo interface hardware, the Console application, or a DAW.*

The primary function of the Console Recall plug-in is to store the current Console configuration within the DAW via the **SYNC** (synchronize) switch in the plug-in. It can also be used to view and adjust Apollo's monitor output level, mono, and mute states without having to leave the DAW.

SYNC

The SYNC switch is not present within the Console application. When a DAW project containing the Console Recall plug-in is saved and the SYNC switch is enabled in the plug-in, the current state of the Console application is stored within the Console Recall plug-in.

When the DAW project file is subsequently reloaded, Console is automatically restored to the previous settings state, regardless of any changes to Console or Apollo that were made in the interim.

Since plug-in settings are saved within DAW project files, using SYNC enables Console's current state to be stored within the DAW project file without saving or loading Console sessions presets via the **Console Sessions** functions.

This feature ensures the DAW project will sound exactly the same when reloaded at a later date, even if Console contains customized settings that might affect the audio, such as send mixes, signal routings, and/or Realtime UAD Processing.

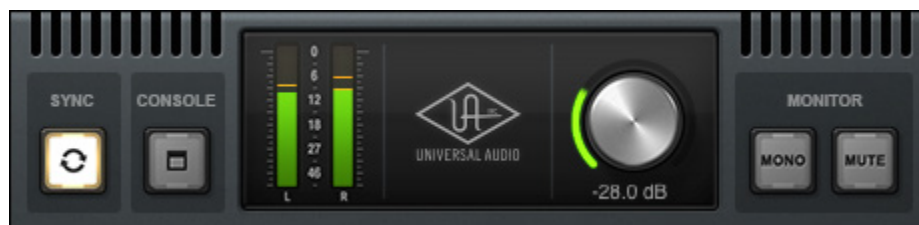

The Console Recall plug-in window

Console Recall Controls

Most Console Recall plug-in controls are duplicates of those found in the Console application. The exceptions are the **SYNC** switch, which is detailed beginning on [page 140](#), and the **CONSOLE** switch, which opens the Console application.



Console Recall plug-In controls

Monitor Controls

The exact same control descriptions in the Console application apply to the Console Recall plug-in controls. Refer to the Console Reference chapter for descriptions of the duplicated controls:

- **Monitor Meters** – Refer to [page 78](#)
- **Monitor Level** – Refer to [page 80](#)
- **Monitor Options** – Refer to [page 80](#)

Console Switch

The Console application can be opened by clicking the **CONSOLE** switch. Note that the Console application does not need to be open when using the DAW with the Console Recall plug-in; Console settings are always captured by the Console Recall plug-in as long as the **SYNC** switch is engaged.

How To Use Console Recall

To use Console Recall, simply place **one** instance of the Console Recall plug-in into any insert slot in the DAW project.

Important: Do not insert more than one occurrence of the Console Recall plug-in within any single DAW project. Doing so could cause unpredictable results.

Because the plug-in does not process audio in any way, the insert location isn't critical. Although it can be placed on any audio track, virtual instrument track, aux bus, output, etc, placing it on the master output is recommended for consistency since projects usually contain an output channel.

Upon instantiation, the plug-in's Monitor Level, Mono, and Mute controls mirror the equivalent controls in the Console application. Enabling **SYNC** causes the current Console settings to be stored within the DAW project.

Enabling SYNC

When Console Recall is first loaded, the SYNC switch is disabled (gray). To activate SYNC, click the switch so it is engaged (lit).



SYNC switch when disabled (left) and enabled (right)

Enabling SYNC does not change the Console settings; SYNC doesn't do anything until the DAW project file is saved and subsequently reloaded.

Important: SYNC saves the Console settings within the DAW file, not the Console application. Therefore the DAW project file must be saved to disk to retain the Console settings in the project.

Effect on Session Name in Console

When a DAW project is loaded that contains the Console Recall plug-in with SYNC enabled, the **Session Name** in the Console application displays “- Sync Session -” and the display is dimmed.

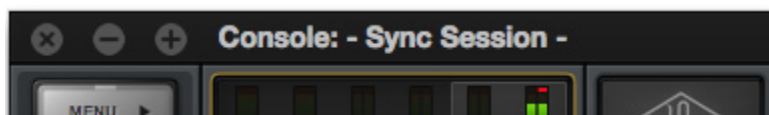

Console session name when SYNC is enabled in DAW

Loading Synchronized DAW Projects

If SYNC was active when a DAW project file containing Console Recall was saved, then loading that DAW project will load the Console settings saved in the plug-in, and the Console settings that were active before the DAW project was loaded are overwritten.

Note: *The Console settings that were active before the DAW project was loaded can be easily recovered if desired using the [Cached Sessions](#) feature in the [Sessions Menu](#) within the Console Application.*

If SYNC was inactive when a DAW project file containing Console Recall was saved, then loading that project will *not* change the Console settings that were active before the DAW project was loaded.

Session State Parameter

The Console Recall plug-in has a parameter called “Session State” that is exposed for DAW automation but is not in the plug-in interface. Session State ensures all changes to Console settings and the DAW session are captured by the Console Recall plug-in. If something related to Session State appears in the DAW, it’s best to just ignore it.

Important: *To ensure proper functionality when SYNC is enabled in Console Recall, do not create or edit DAW automations with the Session State parameter.*



Chapter 8: Unison

What is Unison?



Unison is an exclusive analog/digital integration system that's built into every Apollo microphone preamplifier. It's the first and only way to truly emulate classic analog mic preamp and pedal behaviors in an audio interface.

Unison is an audio processing breakthrough that starts right at the source, the input stage, allowing Apollo's mic preamps to sound and behave like the world's most sought-after tube and solid state preamps — including their all-important impedance, gain stage “sweet spots,” and component-level circuit behaviors.

Apollo's mic preamps are designed for high resolution, ultra-transparent translation from microphone to converter. This clean hardware design is the foundation for adding software color with UAD plug-in processing.

Unison-enabled UAD preamp and pedal plug-ins reconfigure the physical input impedance, gain staging response, and other parameters of Apollo's mic preamp hardware to match the emulated preamp's hardware design characteristics.

Because the hardware and software are intricately unified, Unison provides continuous, realtime, bi-directional control and interplay between Apollo's physical mic preamp controls and the software settings in the Unison plug-in interface.

Controls on Apollo's front panel dynamically adjust the Unison plug-in's parameters to match the target preamp/pedal behavior. Correspondingly, changing a setting in the Unison plug-in interface will modify Apollo's front panel settings.

Because Unison can be active on more than one mic channel, a complement of premium mic preamps is available concurrently.



Unison is enabled by loading a UAD preamp or pedal plug-in into Console's dedicated Unison inserts

Unison Features

Unison technology enables these Apollo features, all with Realtime UAD Processing:

- **Alternate microphone preamplifier sound** – Apollo’s ultra-transparent mic preamps inherit all the unique sonic and input characteristics of the emulated hardware preamp or pedal, including the mic, line, and Hi-Z inputs.
- **Realistic tandem control** – Unison facilitates seamless interactive control of Unison preamp plug-in settings using Apollo’s digitally-controlled hardware and/or the plug-in interface. All equivalent preamp controls (gain, pad, polarity, etc) are mirrored and bi-directional. The preamp controls respond to adjustments with precisely the same interplay behavior as the emulated hardware, including gain levels and clipping points.
- **Hardware input impedance** – All Apollo mic preamps feature variable input impedance in analog hardware that can be physically switched by Unison plug-ins for physical, microphone-to-preamp resistive interaction. This impedance switching enables Apollo’s preamps to physically match the emulated unit’s input impedance, which can significantly impact the sound of a microphone. Because the electrical loading occurs on input, prior to A/D conversion, the realism is faithful to the original target hardware preamp.
- **Tactile gain staging** – Apollo’s front panel preamp knob can independently adjust all gain and level parameters available within the Unison plug-in via [Gain Stage Mode](#). The gain stage being adjusted can be remotely switched via Apollo, so multiple gain levels and their associated colorations can be tuned from the hardware knob for precise physical tactile control, all without using the Unison plug-in’s software interface.

Unison Plug-Ins

Note: In all descriptive text, “Unison plug-in” is defined as any Unison-enabled UAD preamp or UAD pedal plug-in.

Unison-enabled UAD preamplifier and guitar pedal plug-ins are uniquely coded for Unison integration. Only UAD preamp and pedal plug-ins that are Unison-enabled can be loaded in Console’s [Unison Insert Location](#). The available Unison plug-ins are listed in the table below.

Unison-Enabled UAD Plug-Ins	
Unison Preamp Plug-Ins	Unison Pedal Plug-Ins
<ul style="list-style-type: none">• API Vision Channel Strip• Neve 1073 Preamp & EQ• Neve 88RS Channel Strip• UA 610-A Tube Preamp & EQ• UA 610-B Tube Preamp & EQ	<ul style="list-style-type: none">• Bermuda Triangle• Ibanez Tube Screamer TS808• Raw Distortion

Unison plug-ins that can be placed in Console’s Unison inserts

Activating Unison

Unison is activated by inserting any Unison-enabled plug-in into the special Unison insert available on all mic preamp channels.

Tip: Unison can be active on more than one preamp channel concurrently.

Unison Insert Location

The Unison insert is located between the preamp gain knob and the standard channel inserts.

Unison Availability

Unison inserts are available on Apollo devices that feature mic preamps:

Apollo, Apollo 8 – Preamp input channels 1 – 4

Apollo 8p – Preamp input channels 1 – 8

Apollo Twin – Preamp input channels 1 & 2

Apollo 16 – Unison is unavailable (Apollo 16 does not feature preamps)

Unison Processing

Important: *Unison processing in Console's Unison insert is always active on the channel's input signal, regardless of any subsequent channel routing options (Console Flex Routing, DAW I/O, etc). Therefore Unison processing is always recorded in the DAW, even if Console's Insert Effects switches are set to MON.*

Unison plug-ins in channel inserts

UAD plug-ins that support Unison can also be loaded and used in any standard inserts available on all Console input channels and/or within a DAW via VST/AU/RTAS/AAX 64 (as with any UAD plug-in). However, there is no physical or electrical hardware interaction with channel inserts, so Unison plug-ins operate like other (non-Unison) UAD plug-ins in this configuration.

Important: *Unison features are available only when Unison-enabled UAD preamp or pedal plug-ins are loaded within Console in the dedicated Unison inserts.*



Click this area to insert a Unison plug-in

Unique Behavior of Unison Inserts

Console's Unison inserts have some operational differences compared to standard channel inserts, as described below.

Available UAD plug-ins

Only Unison plug-ins are available for selection from the [Insert Assign Popover](#) window when inserting UAD plug-ins into the Unison insert (non-Unison plug-ins are not visible in the Insert Assign window).

Note: All available Unison plug-ins are installed during the normal UAD Powered Plug-Ins software installation process (they are not separately installed).

Linked insert enable and plug-in enable controls

Console's Unison insert enable/disable switch and the Unison plug-in's on/off switch in the plug-in interface are linked. Changing either on/off setting will also change the other setting.

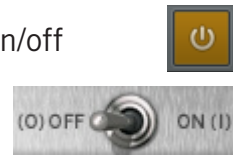

Disabled Unison plug-ins

When a Unison plug-in is unintentionally disabled (for example, when UAD-2 DSP resources are exceeded upon insertion), the red disabled indicator (see [Insert State Indicators](#)) does not appear as it does with non-Unison plug-ins. However, in this situation (unlike standard UAD plug-ins) the following indications do occur:

- The power switch within the Unison plug-in window is switched off
- The Unison insert's enable button is switched off
- Apollo's front panel preamp gain level indicator color reverts to green.

Note: The above functions can be re-enabled after adequate UAD resources are made available.

Line Input Gain Bypass (Apollo 8, Apollo 8p)

When a Unison plug-in is active on a line input and Line Input Gain for the preamp channel is set to BYPASS in Console Settings, the Unison plug-in is disabled. All preamp functionality is disabled with Line Input Gain Bypass. For related information, see [Line Input Gain \(Apollo 8, Apollo 8p\)](#).



Controlling Unison Plug-Ins with Apollo

When a Unison plug-in is inserted in Console's Unison insert, Apollo's front panel pre-amp controls and the Unison plug-in's equivalent preamp controls are mirrored. Adjusting Apollo's front panel preamp controls will adjust the Unison plug-in's preamp controls, and vice versa.

Apollo Front Panel Indication

Unison Active

When a Unison plug-in is inserted in a Console Unison insert *and* Apollo's front panel channel select function is set to the same channel, the color of Apollo's front panel pre-amp gain level indicator (the LED ring around the knob) is orange instead of green.

Note: *Apollo's front panel channel selection indicator must match the Unison-enabled channel to see the front panel Unison indication.*

The orange-colored ring indicates that the currently selected preamp channel is using a Unison plug-in within Console, and that Apollo's front panel knob is controlling the first gain stage of the preamp plug-in (with pedal plug-ins, the knob is controlling the primary effect parameter, e.g., distortion).

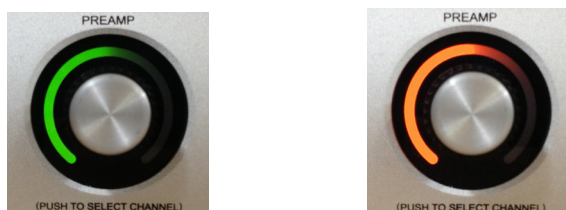

Apollo's front panel preamp knob during normal operation (left) and when a Unison plug-in is in the Unison insert of Apollo's selected channel (right)

Additional Gain Stages

More than one gain parameter within the Unison plug-in can be adjusted using Apollo's front panel knob by activating Gain Stage Mode. When Gain Stage Mode is active, the color of Apollo's gain level indicator, and the target parameter within the Unison plug-in's interface, changes depending on which parameter is currently being controlled by the knob, and the parameter being controlled can be navigated remotely by pushing the knob's switch. See [Gain Stage Mode](#) for details.

Plug-In Parameters

Unison plug-ins may contain parameters that are unavailable for hardware control via Apollo. For example, the UA 610-B has EQ settings, but there are no EQ controls on Apollo's hardware. To adjust these extra parameters, the Unison plug-in interface must be used.

Console Indications

Gain Level Indicator

The color of Console’s preamp gain level indicator (the colored ring around the gain knob), and the channel selection dot on the gain knob, is orange instead of green when Unison is active in the channel.



If the Unison plug-in is inactive (either via the insert disable switch or the power switch in the plug-in interface), the color reverts to green.

Note: Console’s preamp gain control only adjusts the first gain stage of any Unison preamp plug-in, even when Apollo is in Gain Stage Mode.

Gain Level Display

The preamp gain level display (the gain value readout under the knob) always shows the current value of the main parameter within the Unison plug-in. Additionally, the display is adapted to the parameter value and range of the first gain stage within the plug-in.



For example, when the UA 610-A Tube Preamp plug-in is in the Unison insert, this field displays either “Hi” or “Low” because these are the only two values available in the first gain stage of this plug-in.

Note: This display shows “---” if the Apollo hardware is not detected when a Unison plug-in is in the Unison insert and the insert is not disabled.

Front Panel Channel Selection

Level Knob Switch

In addition to the rotary control, Apollo’s front panel preamp level knob has a switch function when the knob is pressed. The function of this switch varies depending on the active mode (either Channel Select Mode or Gain Stage Mode), as described below.

Channel Select Mode (standard operation)

Channel selection determines which input channel can be adjusted with Apollo’s front panel preamp controls. This is the standard behavior when a channel is not in Unison mode; front panel channel selection is not related to Unison functionality.

The method used for front panel channel selection depends on the specific Apollo hardware model (Apollo or Apollo Twin). The method for each model is described briefly below, in order to differentiate the standard behavior from the Unison behavior.

Note: Standard channel selection is also explained in the hardware manual for each Apollo model (the channel selection methods are used without Unison).

Apollo, Apollo 8, Apollo 8p

Pressing the Preamp knob cycles the selection of Apollo's available preamp channels. A channel is selected for adjustment when its channel select indicator LED (located above the channel input meters) is lit. If stereo linking is active, the stereo pair LEDs are lit.

Apollo Twin

Either of these methods can be used for channel selection with Apollo Twin:

- ***Level Knob*** – After the Preamp switch has been pressed at least once to switch the unit to Input mode, pressing the Level knob alternates the currently selected input channel (CH1 or CH2).
- ***Preamp Switch*** – After the Preamp switch has been pressed at least once to switch the unit to Input mode, pressing the Preamp switch alternates the currently selected input channel (CH1 or CH2).

An Apollo Twin channel is selected for adjustment when its channel selection indicator LED (CH1 or CH2, above the input meters) is lit. If stereo linking is active, both indicators LEDs (CH1 and CH2) are lit.

Gain Stage Select (Unison operation only)

When the currently selected Apollo channel is in Gain Stage Mode, pushing the level knob changes the Unison plug-in's parameter that is being controlled.

The color of Apollo's front panel preamp gain level indicator (the LED ring around the knob) changes to reflect the gain stage being controlled, and the gain stage is also indicated by the matching color of the indicator dot within the Unison plug-in's interface. For complete details, see [Gain Stage Mode](#).

Gain Stage Mode

Unison plug-ins have either two or three gain parameters. By activating Gain Stage Mode, each of these preamp plug-in gain stages can be independently adjusted using Apollo's front panel gain knob.

Note: *Gain Stage Mode can only be active on one preamp channel at a time.*

Initially, when Unison is activated (before entering Gain Stage Mode), Apollo's gain knob controls the first gain parameter within the Unison plug-in. However, when Gain Stage Mode is active, pressing Apollo's front panel preamp knob cycles through the available gain parameters in the plug-in.

Activating Gain Stage Mode

To enable Apollo's Gain Stage Mode when using a Unison plug-in:

1. In Console, confirm a Unison plug-in is inserted in the Unison insert of the Apollo preamp channel to be controlled.
2. On Apollo's front panel, select the preamp channel to be controlled using the standard method for your hardware model (for methods, see [page 149](#)).
3. Press AND HOLD Apollo's front panel preamp level knob for at least two seconds.

The state of Gain Stage Mode is indicated on Apollo and in the Unison plug-in, as detailed below.

Gain Stage Mode – Apollo Panel Indication

Apollo's panel channel selection indicator LED flashes when Gain Stage Mode is active for the currently selected preamp channel. The indication varies with the specific Apollo model:

Apollo, Apollo 8, Apollo 8p

The channel selection number LED above its input meter flashes when Gain Stage Mode is active, as shown at right.

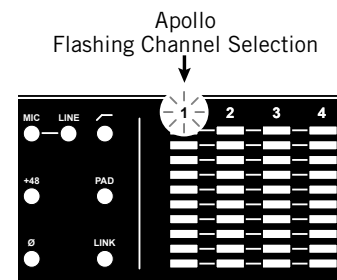

Apollo Twin

The channel selection number LED (CH1 or CH2) above the input meters flashes when Gain Stage Mode is active, as shown at right.

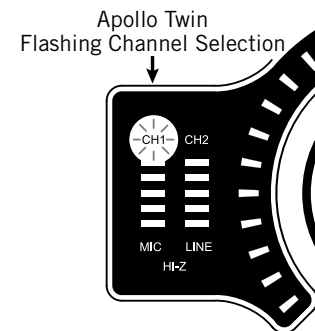

Gain Stage Mode – Unison Plug-In Indication



A colored dot appears within the Unison plug-in interface on the target parameter being controlled, as shown at left.

See [Gain Stage Colors](#) for related information.

Deactivating Gain Stage Mode

Gain Stage Mode can be deactivated with any of these methods:

- Press and hold Apollo's front panel gain level knob for at least two seconds (*Apollo Twin must be in Input mode by pressing the Preamp button at least once*)
- Disable the Unison plug-in via the plug-in editor window within Console
- Disable the Unison plug-in via the on/off parameter within the plug-in interface
- Remove the Unison plug-in from Console's Unison insert
- (Apollo Twin only) Change the selected channel by pressing the INPUT switch on Apollo Twin's top panel

When Gain Stage Mode is deactivated, the following changes occur:

1. The gain stage select function (pushing the gain level knob) reverts to the channel select function
2. The channel selection indicator on Apollo's front panel stops flashing
3. If a gain stage other than the first gain stage was being controlled, Apollo's gain level knob reverts to control of the first gain stage of the Unison plug-in, and the level indicator color reverts to orange.

Controlling Individual Gain Stages

Selecting Gain Parameters For Control

When the currently selected Unison plug-in channel is in Gain Stage Mode (when its [channel selection indicator is flashing](#)), push Apollo's gain level knob to cycle through the available gain parameters within the Unison plug-in.

Note: Unlike Apollo's front panel knob, Console's preamp gain control only adjusts the first gain stage of any Unison plug-in when Apollo is in Gain Stage Mode. To adjust other gain stages from within Console, use Apollo's gain knob or the Unison plug-in interface.

Gain Stage Colors

The gain stage being controlled is indicated by unique, [matching indicator colors](#) on Apollo's front panel and within the Unison plug-in's interface.

The color of the gain level indicator on Apollo's front panel (the LED ring around the knob) changes with each gain stage, and the matching color dot within the Unison plug-in's interface moves to the target gain parameter being controlled.

The gain stages available for control, and their associated colors, are:

- **Orange** – Gain stage one; the Gain parameter
- **Amber** – Gain stage two; the Level parameter
- **Green** – Gain stage three, the clean (non-modeled) output control

Matching Gain Stage Indicators

In Gain Stage Mode, Apollo's preamp level indicator (the colored ring around the knob) matches the colored dot on the target gain parameter in the Unison plug-in's interface, as shown below. The hardware and software controls are mirrored and the gain stage can be adjusted using either control.



The color of Apollo's preamp gain level indicator changes to reflect the gain stage being controlled

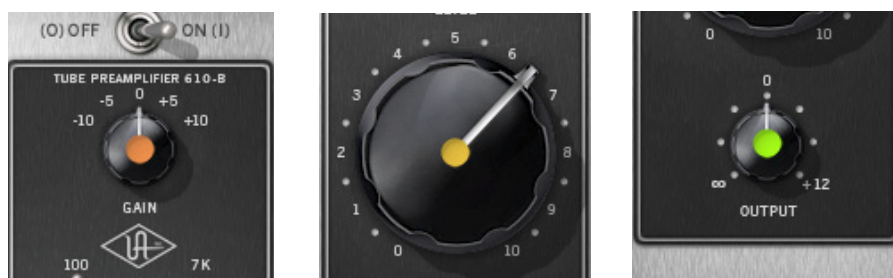

The matching color dot on the parameter in the Unison plug-in interface indicates which gain stage is being controlled by Apollo's front panel preamp knob

Available Gain Stages

Unison plug-ins have up to three gain stage parameters. With Unison plug-ins that contain two gain parameters, only the available gain parameters are cycled and controlled in Gain Stage Mode.

Note: For details about the unique gain stage parameters available within individual Unison plug-in titles, refer to the *UAD Plug-Ins Manual*.

Unison Load/Save Behaviors

Caution: Apollo hardware preamp settings (including +48V phantom power) may change when Console sessions are loaded. Details are explained in this section.

Loading Unison Plug-In Settings

When Unison plug-in settings are loaded in Console, the effect upon the currently active Unison plug-in settings varies depending on how the settings are loaded. Its important to understand the distinction, because critical preamp settings can be affected.

Note: When Unison plug-ins are used in [Console's standard inserts and/or within a DAW](#), this section does not apply. Settings load behavior outside of the Unison insert is like all other (non-Unison) UAD plug-ins.

There are two ways Unison (and non-Unison) plug-in settings can be loaded in Console:

- **Plug-In Presets** – UAD Presets are loaded whenever a UAD plug-in is inserted (the default preset loads). Presets can be loaded from disk files via the [Presets Manager](#) or the UAD Toolbar. Preset files are used to save & load all settings of individual plug-in titles.
- **Console Sessions** – Console sessions are loaded from disk via the [Sessions Manager Pop-over](#), the Console Recall plug-in in a DAW, or by double-clicking Console session files on disk. Console sessions are complete Apollo configurations, containing all hardware and plug-in settings (i.e., Console sessions are Console presets).

Loading Presets: Hardware settings are inherited

When a Unison plug-in is assigned to the Unison insert and a preset is loaded into the plug-in, the plug-in inherits the current equivalent hardware settings of the Apollo preamp, if those settings are available in the plug-in.

In simpler terms, Apollo's preamp settings always override a Unison plug-in's settings when a preset is loaded or the plug-in is inserted. This is done to prevent the plug-in's settings from switching the hardware to values that could cause extreme level changes and/or other unwanted circuit changes such as +48V phantom power.

For example, if the PAD is ON in the Apollo preamp, when the Unison preset is loaded, the pad setting in the plug-in is enabled to prevent unexpected level increases.

Loading Sessions: Hardware settings are overridden

When a Console session is loaded (via Console Recall menu, DAW sessions containing the Console Recall plug-in, or double-clicking Console files on disk), **ALL Console settings are overridden (changed) by the saved session, INCLUDING ALL APOLLO HARDWARE INPUT SETTINGS.**

In simpler terms, Console sessions always override Apollo's preamp settings, even if potentially harmful preamp settings are contained in the session file. This is done because the very concept of Console session recall is to reproduce all settings in the session.

For example, if the PAD is OFF in the Apollo preamp, when the Console session is loaded, the pad setting in the plug-in is disabled and sensitive equipment could be affected, such as speakers (level increases) and/or ribbon mics (+48V phantom power).

Unison Operation Notes

The operating notes in this section only apply to Unison functionality (when Unison plug-ins are loaded in Console's Unison insert).

The notes do NOT apply to Unison plug-ins that are used in Console's standard inserts, nor via VST/AU/RTAS/AAX64 within a DAW, even when a Unison plug-in title is used. In this scenario, Unison plug-ins function the same as all standard (non-Unison) UAD plug-in titles and there is no physical or electrical hardware interaction.

Important: *Unison functionality is available only when Unison-enabled UAD plug-ins are loaded within Console in the unique Unison inserts.*

- Unison insert processing is always recorded in the DAW (regardless of the current [Insert Effects](#) setting) because Unison plug-ins process the physical inputs.
- A microphone, line input, or Hi-Z instrument source must be attached to the Apollo input channel for Unison plug-in processing in the Unison insert to be audible.
- Apollo's hardware preamp controls remain active even if the Unison plug-in is disabled.
- Because Apollo's front panel preamp controls are always current and inherited by the Unison plug-in, changes made to a Unison plug-in when the plug-in is bypassed are not retained when the plug-in is reactivated.
- A Unison plug-in's modeled behaviors and parameter ranges are used by the hardware controls whenever possible, even if the attribute is different than Apollo's stock preamps. For example, if the Unison plug-in has a 15 dB pad, then Apollo's front panel PAD button value will use the Unison plug-in's 15 dB value instead of Apollo's stock 20 dB value.
- Default gain levels when a Unison plug-in is inserted can vary from Apollo's default (non-Unison) preamp levels, and also between various Unison plug-in titles. This is a by-product of accurate preamp modeling. Because hardware preamp designs from each manufacturer vary, they all have different total gain amounts, control ranges, and control response curves, whether Mic, Line, or Hi-Z.
- If a Unison plug-in does not contain settings that are available on Apollo (pad, low cut filter, etc), the Apollo settings are not changed when the Unison plug-in settings are loaded, and the Apollo settings are still available for control via Apollo's front panel and/or Console channel.
- When a Unison plug-in is removed from the Unison insert, Apollo's mic input impedance reverts to its default value of 5.4K Ohms.
- When the original hardware preamp being emulated by the Unison plug-in has a Hi-Z (instrument) input and associated Hi-Z input switch, this switch is unavailable in the Unison plug-in interface. Instead, the Unison plug-in's Hi-Z input is automatically selected when a mono (tip-sleeve) plug is inserted into the Unison channel's front panel Hi-Z input jack.

(Continued)

- If Apollo is disconnected from the host computer (standalone mode), the Unison plug-in can no longer be controlled from Apollo's front panel. However, the signal continues to be processed by the Unison plug-in, using the values that were active when the connection was lost. Note that if Gain Stage Mode is active when the host connection is lost, the gain stage can apparently be switched from the front panel. However, the actual gain stage being controlled does not change.

Chapter 9: Working With Apollo

Apollo Setups Overview

Apollo is a powerful and flexible audio interface that can be used in many ways. This chapter explains how to apply Apollo in various digital audio environments.

Although the exact techniques for configuring and using Apollo will vary according to needs, its application will generally fall within one of the main categories below. Each application is detailed later in this chapter.

Audio interface without DSP

Apollo functions like other non-DSP audio interfaces when it is used without the Console application, the Console Recall plug-in, or UAD Powered Plug-Ins. See [“Using Apollo as an Audio Interface” on page 160](#) for details.

Digital mixer with Console

Apollo and Console can be used without a DAW or any other audio software, providing access to all Apollo features, its DSP mixing functionality, and Realtime UAD Processing. See [“Using Apollo with Console \(without a DAW\)” on page 162](#) for details.

Standalone use without computer

Apollo can be used as a digital mixer (with limited functionality) without Console or any connection to a host computer. See [“Using Apollo Without A Computer” on page 163](#) for details.

With a DAW (without Console)

When Apollo is used with a DAW but without the Console application (or Console Recall plug-in), the DAW controls all signal I/O routing, software monitoring, and UAD-2 DSP-accelerated UAD Powered Plug-Ins processing. See [“Using Apollo with a DAW \(without Console\)” on page 164](#) for details.

With Console and a DAW

Console is used concurrently with a DAW when low-latency monitoring and/or recording of Apollo’s inputs with (or without) Realtime UAD Processing is desired. This workflow completely eliminates the I/O buffering latencies associated with software monitoring. Console’s Virtual I/O feature can also be used with the DAW to route virtual software instruments, or any other DAW outputs, into Console for Realtime UAD Processing. See [“Using Apollo Concurrently with a DAW and Console” on page 167](#) for details.

UAD Powered Plug-Ins: Console versus DAW

There are some fundamental differences when UAD Powered Plug-Ins within Console or within a DAW. See [“About UAD Powered Plug-Ins Processing” on page 158](#) for details.

About UAD Powered Plug-Ins Processing

Two Distinct Methods with Apollo

Apollo features two distinct methods for using UAD Powered Plug-Ins: The “Console processing method” for low-latency monitoring and tracking with Realtime UAD Processing via the Console application, and the “DAW processing method” for DSP-accelerated UAD-2 processing via VST, RTAS, AAX 64, and Audio Units plug-ins in DAW applications.

These two methods are not a switched mode, but instead simply depend on which application (Console or DAW) uses the UAD plug-ins. Both methods can be used simultaneously for extremely powerful and flexible signal monitoring, routing, and processing.

Console Processing Method

UAD plug-ins run in realtime only when used within Console. Using Realtime UAD Processing in Console is optimum for artists and engineers that need to monitor and capture performances without DAW I/O buffering latency and its associated hindrances.

The special Realtime UAD Processing functionality is achieved via Apollo’s unique ultra-low latency DSP+FPGA+Console design. Although *every* audio interface has undetectable latency that is inherent to the A/D–D/A process, routing Apollo’s input signals through UAD plug-ins within Console *does not add to this inherent latency*.

Up to four UAD plug-in instances can be inserted serially (“stacked” or “chained”) on each of Console’s analog/digital inputs and/or auxiliary buses simultaneously, without adding to the inherent I/O latency.

Note: *Upsampled UAD plug-ins add latency when used within Console or a DAW. See [Upsampled UAD plug-ins](#) for more information.*

Console inputs with Realtime UAD Processing can be routed into the DAW via Apollo’s device drivers, and optionally recorded as either processed (wet) or unprocessed (dry) audio using the Insert Effects feature in Console (see the [Insert Effects Overview](#)).

Note: *UAD plug-ins used within Console for Realtime UAD Processing must run on the DSP within Apollo. If other UAD-2 devices are active in the same system, DSP on those devices cannot be used for Realtime UAD Processing.*

DAW Processing Method

When UAD plug-ins are used within compatible VST, RTAS, AAX 64, or Audio Units host DAW applications, I/O buffering is used for plug-in processing because the data must be shuttled back and forth between the DAW and Apollo. In this scenario, the UAD-2 DSP inside Apollo behaves exactly like other UAD-2 devices such as UAD-2 Satellite and UAD-2 PCIe cards for UAD plug-in processing.

Hardware I/O buffering with a DAW adds latency that is compensated by the host DAW's automatic output delay compensation during mixing (i.e., all tracks remain time-aligned). However, at larger buffer sizes this latency makes software monitoring via the DAW mixer while tracking with UAD plug-ins less practical. [Using Apollo Concurrently with a DAW and Console](#) eliminates this latency during tracking because software monitoring is not used — the DSP mixer inside Apollo is used for “hardware” monitoring instead.

***Note:** See “[Chapter 11: Latency & Apollo](#)” on [page 178](#) for detailed information about latency.*

Latency is not an issue during mixdown in a DAW; realtime processing is not necessary because the performances are already captured. The benefits of using Apollo's integrated DSP acceleration during mixing include the off-loading of plug-in processing from the host computer's CPU and the sonic rewards of UAD plug-ins, which run exclusively on UAD-2 and Apollo platforms.

Concurrent use of UAD Plug-Ins in Console and a DAW

UAD plug-ins can be used within Console and a DAW simultaneously. In this scenario, Apollo's DSP resources are shared between the two applications. Realtime UAD Processing is available via Console, and I/O buffered (non-realtime) UAD processing is available via VST, RTAS, AAX 64, or Audio Units plug-ins in the DAW. See [page 167](#) for complete details.

Using Apollo as an Audio Interface

Apollo functions like other (non-DSP) audio interfaces when it is used without the Console application, the Console Recall plug-in, or UAD plug-ins. Apollo's [Core Audio](#) drivers enable it to be used for computer audio I/O routing with any Core Audio-compliant audio software, including DAWs, music players (e.g., iTunes), system software alert sounds, and similar applications.

Accessing Apollo I/O via Core Audio

Audio is routed to and from Apollo via its Core Audio device drivers. The audio software accesses Core Audio interfaces directly via the audio settings/preference panel in the audio software, or it uses the audio device set as the preference in the operating system.

Apollo I/O Driver Names

Each Apollo input and output has a channel number and name provided by the Apollo drivers to Core Audio. If an audio software application can access Core Audio devices directly, it may be possible to designate specific inputs and/or outputs within the application.

All Apollo Driver I/O numbers and names are listed in [“Driver I/O Tables” on page 185](#). These values can be used to reference specific Apollo inputs or outputs by number or name if allowed by the application.

Setting the I/O in the audio software application

To access Apollo's I/O in an audio software application that can select Core Audio devices directly, look for a setting in the audio software application's preferences called “audio setup” or “output device” or similar. Each application is different; consult the software application documentation for specifics.

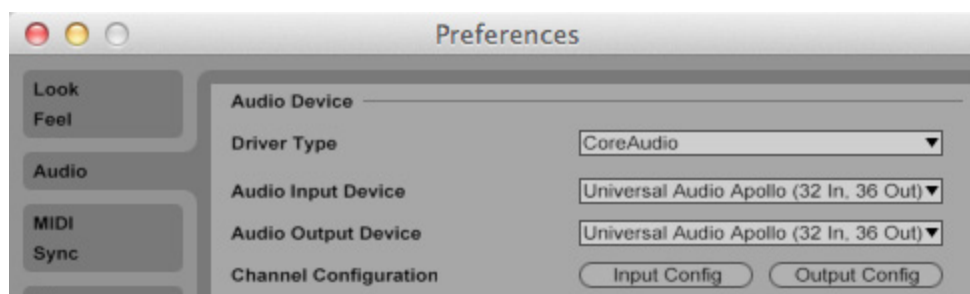

Apollo selected as the Core Audio I/O device in Ableton Live preferences

Setting the I/O in the Operating System

If a software application doesn't have its own setting for accessing a Core Audio device directly, it typically uses the device specified in the "Sound" control panel of the OS software. This sets the device for all system sounds, and any other device that uses the system device for audio I/O.

Note: To prevent system sounds from being inadvertently routed into Apollo's monitor outputs and/or DAW recordings, setting Apollo as the output for system sounds is generally not recommended when using a DAW.

Set the operating system's Input and/or Output device to use "Universal Audio Apollo" to route system sound to/from Apollo. This setup will assign system audio to the Apollo's default channels (1 & 2), which are routed to Apollo's left & right monitor outputs.

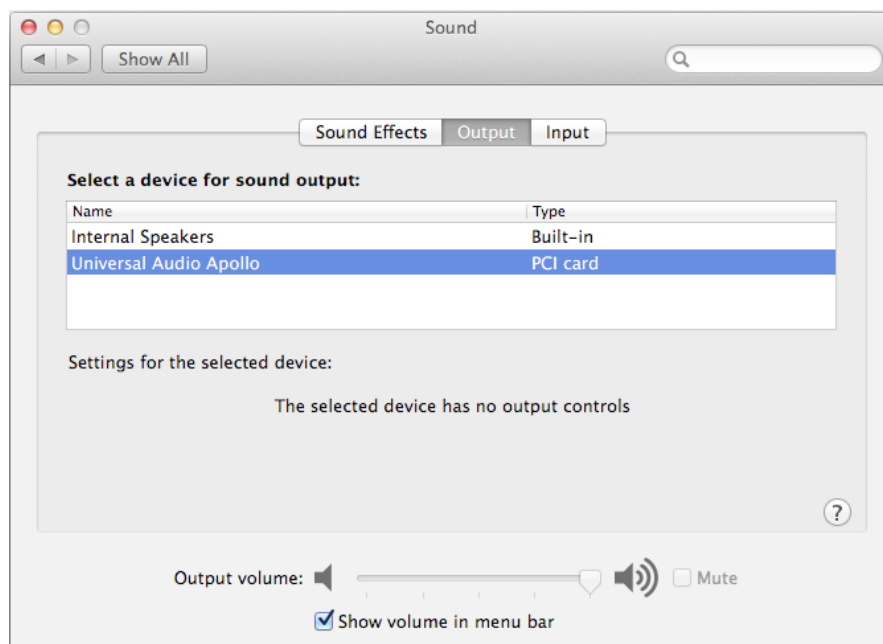

Apollo selected for system audio output in Mac OS X System Preferences

Using Apollo with Console (without a DAW)

Apollo and Console can be used without a DAW or any other audio software. Using Console without a DAW provides access to all Apollo functionality and simplifies the use of Apollo's digital mixing, monitoring, and Realtime UAD Processing features when a DAW's recording and playback features are not needed.

Apollo has an internal DSP mixer for realtime mixing and monitoring of Apollo inputs, with optional Realtime UAD Processing using UAD plug-ins. The software interface for this functionality is the Console application, but the actual mixing and signal processing occurs inside Apollo.

Using Console by itself

To use Console by itself for input monitoring and Realtime UAD Processing, there aren't any special considerations; just launch Console and start using it. Full explanations of all Console features and functionality are in [“Chapter 4: Console Reference” beginning on page 45](#).

Using Console with other audio applications

System Audio

When the OS is set to use Apollo for computer system audio ([page 161](#)), the computer system audio is routed to Console's monitor outputs and mixed with Apollo inputs (if any).

Apollo's input levels can be adjusted with Console's input channel faders, while the computer system's audio level at the monitor outputs is determined by the volume settings of the audio software using the system outputs. The computer system volume level is not adjusted with Console's input faders.

With a DAW

Digital Audio Workstations have their own audio mixer. Understanding the interactions between Console and the DAW will help to ensure an optimized workflow in this scenario. See [“Using Apollo Concurrently with a DAW and Console” on page 167](#) for details.

Using Apollo Without A Computer

Standalone Use (single unit only)

Although the Console application and/or a DAW are required to unleash the full potential of Apollo, a single unit can be used as a standalone digital mixer with limited functionality without any Thunderbolt connection to a host computer.

Console settings that are retained on power cycle

All currently active I/O assignments, signal routings, and monitor settings are saved to internal firmware before Apollo is powered down, and recalled when power is re-applied. Therefore these last-used settings are available even when a host computer is not used.

UAD plug-ins are not retained on power cycle

UAD plug-in instantiations are not retained after powering down then powering up again, because the plug-in files must be loaded from the host computer.

Standalone use with UAD plug-ins (single unit only)

If UAD plug-ins are active when Apollo's connection to the host computer is lost (either by disconnecting the cable or shutting down the computer), Console's current UAD plug-in configurations remain active for Realtime UAD Processing until Apollo is powered down.

Disconnecting

Upon disconnection from the host computer, the following changes occur:

- Auxiliary buses are unmuted
- Solo is deactivated on all channels
- If multi-unit cascading, the clock source switches to Word Clock

Operation

After disconnecting, the following behavior applies:

- The LINK switch on Apollo's front panel cannot be used to link or unlink stereo channels. This point only applies if the host connection was lost; the switch does operate when Apollo is powered on before connecting to a host computer.
- If channels 1 & 2 are stereo linked and an instrument is plugged into one of the Hi-Z inputs, the stereo link is unlinked, and UAD plug-in processing is bypassed on both channels. The stereo link, and UAD processing, returns when the Hi-Z input is removed.

Standalone use with Apollo Multi-Unit Cascading

Apollo uses Thunderbolt for inter-unit clocking and audio distribution when multiple Apollo devices are connected. Because the host computer is the master Thunderbolt controller, inter-unit clocking, and therefore standalone use, is not possible with Apollo multi-unit cascading.

Important: Standalone use is not compatible with Apollo multi-unit cascading.

Using Apollo with a DAW (without Console)

When used with a DAW but without the Console application (or Console Recall plug-in), the DAW controls all signal I/O routing, software monitoring, and DSP-accelerated UAD plug-in processing.

***Note:** Apollo, like other UAD devices, can only load UAD plug-ins which are specifically designed to run on UAD DSP accelerators. Host-based “native” plug-ins cannot run on the UAD DSP.*

Monitoring with the DAW

The primary function of Console is monitoring of Apollo’s inputs during live performance, with (or without) Realtime UAD Processing. When software monitoring is enabled in the DAW, Console’s input monitoring must be disabled to eliminate doubled signals.

***Important:** When the DAW’s software monitoring feature is enabled (when not using Console for input monitoring), Console’s inputs must be muted to avoid signal doubling at Apollo’s monitor outputs.*

Disable input monitoring in Console when software monitoring via the DAW

If Console’s input monitoring isn’t disabled, phasing and/or doubling of the monitored signal(s) will occur, because the input signal is being heard twice – first from the low-latency DSP mix (Console) and shortly thereafter from the higher latency software mix (DAW).

How to disable input monitoring in Console

To disable input monitoring in Console when using software monitoring in the DAW, open Console and mute all input channels within Console. Console can then be quit.

***Tip:** In Console, option-click any input MUTE switch to quickly toggle the mute state of all inputs.*

Using a DAW without Console is a typical workflow during mixdown, where low-latency monitoring is not required and buffering latency is not an issue because the tracks are already recorded. When recording new tracks, the DAW+Console workflow (following section) is recommended.

In this scenario, Apollo functions as two “separate” devices: an audio interface, and a UAD-2 DSP accelerator:

1. **Audio Interface** – The DAW accesses and routes Apollo’s audio interface I/O via the Core Audio or ASIO device drivers. Audio I/O latency is determined by the [I/O Buffer Size](#) setting.
2. **UAD-2 DSP Accelerator** – The DAW controls Apollo’s internal UAD-2 DSP via UAD plug-ins in VST, RTAS, AAX, or Audio Units format that are loaded within the DAW. Buffering is used for UAD plug-ins because data from the DAW must be shuttled over Thunderbolt to/from Apollo’s DSP.

Accessing Apollo's I/O in a DAW

Specifying the audio interface device

To access Apollo's I/O within a DAW, the DAW's audio engine must be configured to use Apollo as the audio interface device. Specific instructions vary by DAW; consult the DAW documentation for specifics. The [I/O Buffer Size](#) setting, which determines the overall DAW I/O latency, is usually set in the same window.

See [“Setting the I/O in the audio software application” on page 160](#) for an example.

I/O Complement

The specific default inputs and outputs available, and their names, vary by Apollo model. Note that Apollo's I/O routes and I/O names can be customized in the [Core Audio Panel](#) within the Console Settings window.

Selecting Apollo's Inputs and Outputs

When the DAW is configured to use Apollo as the audio interface device, the DAW's audio input and output channels can be routed to/from Apollo's I/O via the device drivers.

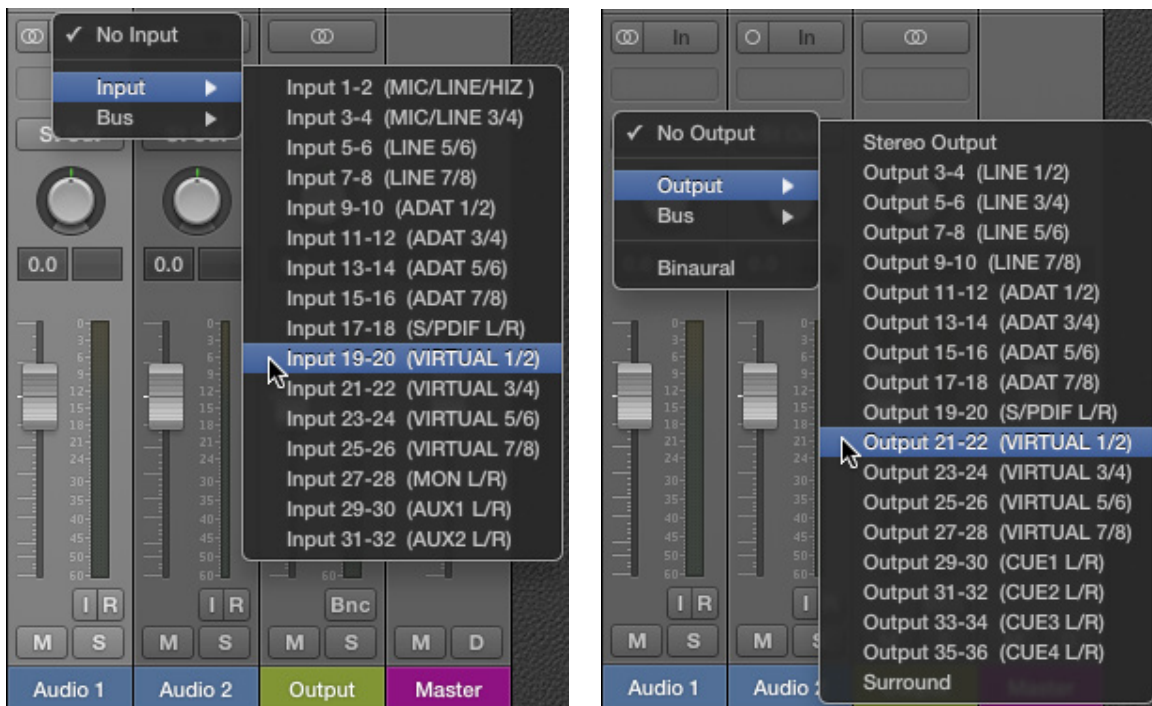

Apollo's inputs (left) and outputs (right) as they appear when configuring stereo I/O in Logic Pro X

Default Outputs

The main stereo outputs of a DAW usually output to channels 1 & 2 by default. Therefore, since channels 1 & 2 correspond to Apollo's monitor outputs, the DAW's main outputs are sent to Apollo's monitor outputs by default. The channels used for output can usually be changed in the DAW.

Apollo I/O Driver Names

Each Apollo input and output has a channel number and name provided by the Apollo drivers. The DAW uses these numbers or names to designate the specific inputs and/or outputs within the DAW.

Numbers vs. Names

Apollo's drivers describe all I/O channels by name and number, but what is actually displayed depends on each particular DAW. Names are not displayed by all DAWs (e.g., Ableton Live), or the driver name display mode may need to be changed in the DAW (e.g., Apple Logic Pro).

All Apollo driver I/O numbers and names are listed in [“Driver I/O Tables” on page 185](#). These values can be used to reference specific Apollo inputs or outputs by name when selecting I/O in an application that does not display the driver names.

***Tip:** Apollo's I/O routes and I/O names can be customized in the [Core Audio Panel](#) within the Console Settings window.*

Using Apollo Concurrently with a DAW and Console

Console is used concurrently with a DAW when low-latency monitoring and/or recording of Apollo's inputs or mix buses with (or without) Realtime UAD Processing is desired. This workflow completely eliminates the I/O buffering latencies associated with software monitoring.

In this scenario, Console is used to control all input monitoring and Realtime UAD Processing when recording, and the DAW's software monitoring feature should be disabled.

Software Monitoring versus Hardware Monitoring

Software monitoring (listening to live inputs via the DAW mixer) has discernible latency due to audio interface I/O buffering. Hardware monitoring via an audio interface's internal DSP mixer (e.g., Apollo's Console application) does not have discernible latency, because the live audio is internally routed directly from the inputs to the outputs without DAW I/O buffering (see [“Latency Basics” on page 181](#) for detailed explanations).

Monitoring with Console

The primary function of Console is monitoring of Apollo's inputs during live performance, with (or without) Realtime UAD Processing. When used with a DAW, Console is used as a monitor mixer that functions separately from the DAW's software monitoring mixer.

Disable Software Monitoring in the DAW when using Console

When Console is used for live input monitoring with a DAW, the DAW's software monitoring feature should be disabled. If it isn't, phasing and/or doubling of the monitored signal(s) will occur, because the input signal is being heard twice – first from the low-latency DSP mix (Console) and shortly thereafter from the higher latency software mix (DAW).

Important: *To eliminate doubled signals, disable software monitoring in the DAW when Console is used to monitor Apollo's inputs. Refer to the DAW documentation for specific instructions on how to defeat software monitoring in the DAW.*

Routing and Recording Console Inputs and Mix Buses

Recording Apollo inputs

This functionality is covered in [“Accessing Apollo's I/O in a DAW” on page 165](#).

Recording Console mix buses

Console's monitor and send bus outputs can be routed into the DAW for recording Console's active mixes. See [“Virtual I/O” on page 169](#) for details.

Recording Realtime UAD Processing

When monitoring Apollo's inputs with Realtime UAD Processing, those inputs can be recorded with processing (wet) or without processing (dry). This function is accomplished with the Insert Effects switch. See the [Insert Effects Overview](#) for details.

Console with the Console Recall Plug-In

The Console Recall plug-in offers additional convenience when using Apollo and/or the Console application in conjunction with a DAW. Its primary function is to store complete Console settings within the DAW project file.

When a DAW project is loaded containing the Console Recall plug-in and the “Synchronize” function in the plug-in is enabled, the Console settings stored within the newly-loaded DAW session are sent to Console. See [“SYNC” on page 140](#) for details.

Latency Compensation

Some latency is inevitable in complex digital audio environments such as when running a DAW with Console. Fortunately, when these applications are properly configured and operated, latency is not a deterrent because it is negligible during low-latency monitoring via Console, and automatically managed for time-alignment of recorded tracks via the DAW’s automatic delay compensation feature.

See [“Delay Compensation with Apollo” on page 178](#) for more information.

Recording multiple inputs simultaneously

Console’s Input Delay Compensation feature should be enabled to maintain phase alignment when monitoring and/or recording simultaneous multi-channel sources (such as a drum kit or multi-mic’d guitar amp) when Realtime UAD Processing is active in Console and some (or all) of the UAD plug-ins in Console are upsampled. See [“Input Delay Compensation in Console” on page 178](#) for complete details.

Latency Basics

For a complete overview of latency in a digital audio system, see [“Latency Basics” on page 181](#).

Virtual I/O

Overview

Apollo's device drivers carry various *virtual* (software only) input and output channels in addition to those directly associated with the hardware inputs and outputs. The virtual channels consist of Console's virtual inputs, Console's virtual outputs, and Console's aux and monitor bus outputs.

Flexible, Pristine Signal Routing

Virtual I/O facilitates highly flexible signal routing via the DAW, without needing to reach behind the gear rack for manual cable patching. Additionally, because the virtual I/O channel audio streams are in the digital domain, a pristine audio signal path is maintained without requiring additional A/D–D/A conversions.

Virtual Inputs into Console

The virtual input channels enable any DAW output to be routed directly into Console's virtual inputs so Realtime UAD Processing with UAD plugins can be applied to the DAW signal(s).

This feature is particularly useful when performing live with virtual software instruments inserted in the DAW, because the throughput latency associated with I/O buffering is reduced in this configuration.

DAW outputs can be digitally routed into Console inputs for Realtime UAD Processing



Virtual Outputs into DAW

Virtual outputs enable any (or all) of Console's virtual input channels and the monitor and aux mix bus outputs to be directly routed to any DAW input so they can be recorded. With virtual outputs, it's easy to capture Console signals, with or without Realtime UAD Processing.

Console outputs can be digitally routed into DAW inputs for recording and/or further routing



How To Route Any DAW Output Into Console's Virtual Inputs

To route a DAW output signal into Console for Realtime UAD Processing, simply assign any Console virtual channel (or channel pair, when the DAW source is stereo) as the output device for any DAW track, bus, or output. That DAW output signal then appears in the associated virtual input channel in Console, and it can be processed or routed the same as Apollo's hardware inputs.

At Right: Routing a DAW channel's outputs into Console's virtual inputs

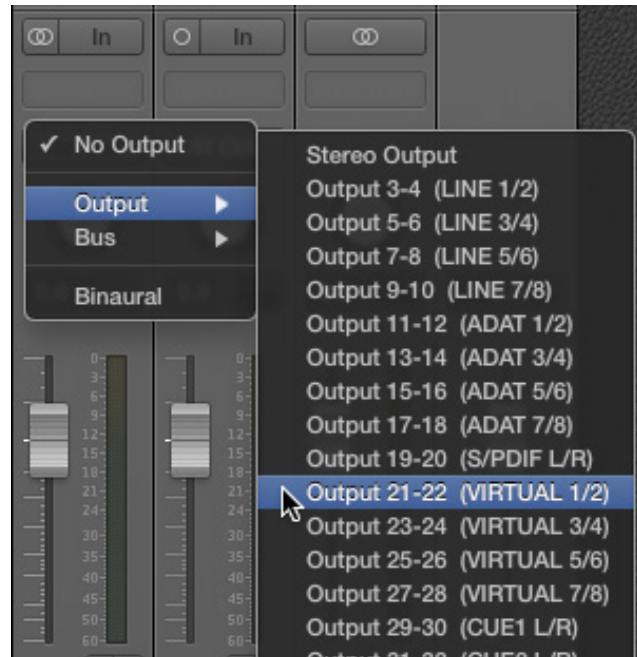

How To Route Any Console Virtual Output Into the DAW

To route a Console output signal into the DAW so it can be recorded, simply assign any Console virtual channel (or channel pair, when the Console source is stereo) as the input source for any DAW input. That Console signal can then be recorded or routed like any hardware input by the DAW.

Tip: This technique can be used to re-capture and record (bounce) a software instrument performance that was virtually routed from the DAW into Console for Realtime UAD Processing.

At right: Routing Console's virtual outputs into the DAW channel's input. Note that any virtual output listed here (including Console's monitor and aux mix buses) could be used as the DAW input.

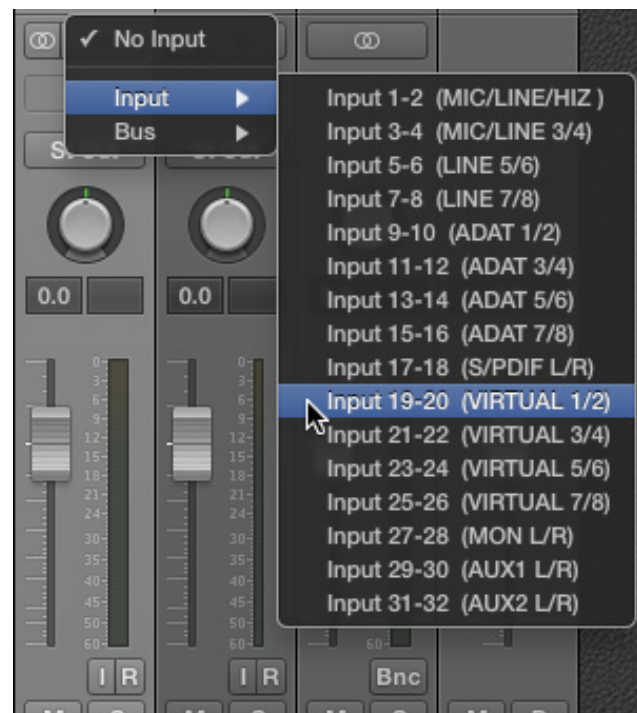

Chapter 10: Multi-Unit Cascading

Apollo Expanded Overview

Up to four Apollo units of any model type (Apollo, Apollo 8, Apollo 8p, Apollo 16, Apollo 16 mkII, Apollo Twin) can be connected and used together as a single consolidated system. When multiple Apollo units are connected, all units are controlled within a single Console window, and the I/O complement of all devices are available within the DAW. Operating a multi-unit system is nearly identical to that of a single-unit system for seamless expansion when more I/O is needed.

Console Integration

When multi-unit cascading, the number of Console inputs is increased to match the increased hardware inputs. Both units share the same monitor, auxiliary, and cue mix buses for integrated mixing convenience.

Monitor and Expander Units

To facilitate the mix bus integration within Console, one unit must be designated as the monitor (master) unit. Monitor speakers and cue outputs are attached to the monitor unit only. All other units are expander (slave) units. For details, see [Monitor Unit Designation](#).

Tip: Headphone outputs can be freely assigned to any master or slave unit.

Hardware Setup

In multi-unit systems, all Apollo devices are interconnected via a single Thunderbolt cable per unit, with a single Thunderbolt connection to the host computer. The host computer port, as well as any Thunderbolt devices on the bus (including Apollo), can be Thunderbolt 1 or Thunderbolt 2.

Constraints

Depending on the specific configuration, certain features and/or I/O streams are reduced when multi-unit cascading. See [Multi-Unit Constraints](#) for details.

Driver I/O

Apollo I/O availability and numbering changes when multi-unit cascading. I/O routes can be virtually remapped via Apollo's [Flex Driver](#) feature. For a list of default I/O states, see "[Driver I/O Tables](#)" on page 185.

Multi-Unit Wiring

This page explains how to interconnect multiple Apollo units and the Mac computer.

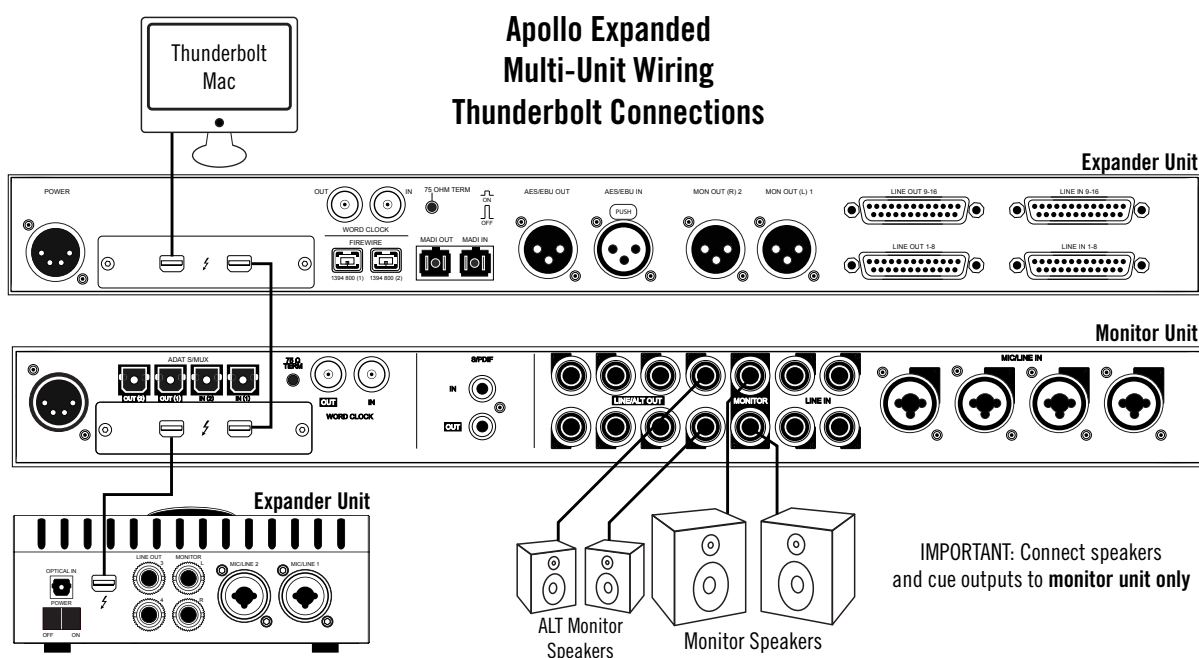

Device wiring example with Apollo 8, Apollo 16, and Apollo Twin

Cables Required

- One Thunderbolt cable for each Apollo unit

Important: All original (silver) Apollo and Apollo 16 units require the Thunderbolt Option Card.

Apollo Expanded Wiring Notes

- A single Thunderbolt cable is required for all Apollo unit interconnections. Connect one cable to the host Mac and one cable between Apollo units.
- Thunderbolt 1 or Thunderbolt 2 ports may be mixed and used for any/all connections.
- The Mac and all Apollo units must be connected to the same Thunderbolt bus.
- The Apollo device ordering and the Thunderbolt ports used (second port on Apollo vs. second port on Mac, placement in daisy chain, etc) is not important.
- In the wiring example diagram, the Apollo 8 in the center is designated as the monitor (master) unit. Connect speakers (including ALT speakers) to the monitor unit only.
- Do not connect more than one Thunderbolt cable between the same two devices (the Thunderbolt protocol is bi-directional).
- Do not interconnect any Word Clock, FireWire, ADAT, or MADI ports between any Apollo units.

Multi-Unit Operation

Power On Sequence

With UAD version 8.0.2 and higher, Thunderbolt devices may be connected and/or disconnected when the computer and/or devices are powered on (hot plugging). The order in which the Apollo units are connected and/or powered on is not critical. Apollo units are automatically detected a few moments after connection.

Multi-Unit Monitoring

To facilitate the mix bus integration within Console, one unit must be designated as the monitor (master) unit. All other units are expander (slave) units.

Monitor Unit Designation

The Apollo unit at the top of the column in the Hardware panel within the Console Settings window is the designated monitor unit. The monitor unit is indicated by a small orange speaker icon next to its unit letter.

A different unit is designated as the monitor unit by dragging the unit to the top of the Devices Column, as shown in the screenshots below. The monitor/expander designations can be changed at any time.

Important: Changing the monitor unit designation changes the driver I/O configuration. Quit all audio applications before performing this action. Additionally, wait for this operation to complete before making further adjustments.



Designating the monitor unit in the Hardware panel within Console Settings

Multi-Unit Monitor Outputs

When multi-unit cascading, all units share the same monitor mix bus. The monitoring speaker system (including ALT monitors, if configured) must be connected to the monitor outputs of the monitor unit only.

Note: When changing the monitor unit designation, the monitor speakers must be physically connected to the new monitor unit to hear the monitor outputs.

Monitor Outputs on Expander Units

When multi-unit cascading, the monitor outputs of all expander units are available as additional line outputs via Flex Driver (in the Core Audio panel within the Console Settings window). In this configuration, the monitor outputs of the expander units are not affected by the Monitor Level knob.

Multi-Unit Headphone Outputs

All headphone outputs for all connected Apollo units (monitor and expander) are available to output the monitor or cue mix buses via the [Cue Outputs Popover](#).

Multi-Unit Cue Outputs

Cue mix buses can be routed to physical outputs (line, ADAT, etc) on the monitor unit only. However, cue mix buses can be sent to any available headphone output via the [Cue Outputs Popover](#).

Multi-Unit Monitor Control

Monitor Knobs

The monitor knob on the front panel of expander units (except Apollo Twin, as below), and its surrounding green LED indicator ring, are disabled. To adjust the monitor output level, the front panel monitor knob on the monitor unit (or the monitor level controls in Console or the Console Recall plug-in) must be used.

Apollo Twin Remote

When Apollo Twin is connected in a multi-unit system, its monitor knob mirrors that of the monitor unit for volume and mute control. This feature offers convenient desktop control of the monitor and ALT speakers.

Multi-Unit Clocking

All multi-unit clocking is carried via Thunderbolt. All connected Apollo units always clock (slave) from the monitor (master) unit, whether set to internal or external clock.

Important: Do not interconnect any FireWire, ADAT, Word Clock, or MADI ports between any Apollo units.

Internal

When multiple units are connected via Thunderbolt, all system clocking and clock settings are automatically configured by Apollo's device drivers. The clock setting in Console's Info Bar (and its mirrored setting in the Hardware panel within the Console Settings window) must remain on INTERNAL unless specifically clocking to an external (non-Apollo) device.

Note: When Apollo's clock source is set to INTERNAL, "EXT" will illuminate on the front panel hardware of the expander units.

External

When using an external (non-Apollo) clock, connect the external clock to the monitor unit only. All connected Apollo units are automatically configured to use the external clock when Apollo's Clock is set to EXTERNAL.

Important: When synchronizing to external clock, connect the external clock source to the monitor unit **only**. The expander units always synchronize to the monitor unit.

Distinguishing Multiple Units

Device Color

Each unit in the Devices list is color coded for enhanced identification. These colors are used in the [Meter Bridge](#) and the [Core Audio Panel](#) when multi-unit cascading to differentiate between devices. The device colors cannot be modified.

Device Name

When using multiple devices of the same type, it may be helpful give each device a unique [Device Name](#) instead of the default names. The [Show Device Names](#) setting is particularly useful with multiple devices.

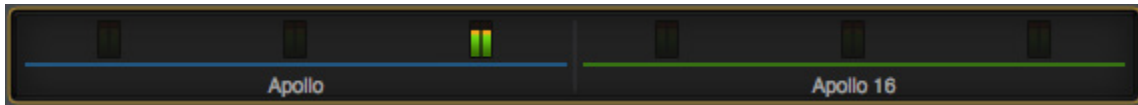

The Meter Bridge with Apollo and Apollo 16, showing unique device colors

Device Letter

Each unit in the Devices list is designated with a sequential letter. These letters are used in the [Core Audio Panel](#) when multi-unit cascading to differentiate between Apollo devices. The device letters cannot be modified.



Device letters & colors correspond in the Hardware panel (left) and Core Audio panel (right)

Console Session Management

Console 1 to Console 2 Session

If a Console session was created and saved with Console 1 and the session is subsequently opened with a multi-unit Thunderbolt setup in Console 2 (UAD v8.0.1 or later), the previous Console 1 configuration is retained, with the exception noted below.

***Note:** Cue and headphone management settings are handled differently in Console 2 sessions. These settings are not retained when updating a Console 1 session.*

Single-to-Multi Session

If a Console session was created and saved with a single-unit setup and the session is subsequently opened with a multi-unit setup, the expander unit(s) is automatically added to the session and the number of Console inputs expands accordingly. All settings from the single-unit session are maintained.

Multi-to-Single Session

If a Console session was created and saved with a multi-unit setup and the session is subsequently opened with a single-unit setup, the expander unit(s) settings are retained in the session for offline configuration. The expander unit(s) can be removed from the session via the `if` desired.

Multi-Unit Constraints

Certain features are reduced when multi-unit cascading due to technical constraints required to maintain integrated mix buses with Realtime UAD Processing capabilities.

All multi-unit constraints are listed below.

- Multi-unit cascading is unavailable at sample rates of 176.4 kHz or 192 kHz.
- Cue buses can be routed to the line and/or digital outputs of the monitor unit only. This constraint does not apply when routing cues to headphone outputs.
- [Flex Routing](#) destinations can be only be assigned to outputs on the same unit as the input. It's not possible to cross-route from one unit to another.
- Apollo uses Thunderbolt for inter-unit clocking when multiple Apollo devices are connected. Because the host computer is the master Thunderbolt controller, inter-unit clocking, and therefore standalone use, is not possible with Apollo multi-unit cascading.
- Connecting two Apollo Twin units is not a compatible configuration.

Chapter 11: Latency & Apollo

Delay Compensation with Apollo

System Latency Overview

System latency encapsulates all latencies induced within the typical digital audio workstation environment. See [“Latency Basics” on page 181](#) for a detailed overview of where, when, and how latency is induced in this environment.

Driver Reporting

Any system latency that is induced by Apollo’s I/O, Console, and/or UAD Powered Plug-Ins is reported by Apollo’s device drivers to the host audio software that is using the device.

The host software uses this reported device latency for its automatic delay compensation (ADC) engine. When properly configured in the DAW, ADC maintains phase coherency (time alignment) throughout the recording, overdubbing, and mixing process.

Automatic Delay Compensation in the DAW

Generally speaking, ADC should be enabled in the DAW when using Apollo, regardless of whether or not Console is used concurrently. The DAW’s ADC will perform the necessary housekeeping to keep tracks phase-aligned, regardless of the latency source (if any).

Input Delay Compensation in Console

Console has automatic Input Delay Compensation (IDC), which is controlled by the [Input Delay Compensation](#) menu in Console Settings. Console IDC maintains phase alignment across all Console’s analog and digital inputs when upsampled UAD plug-ins are used in Console.

For example: If two microphones are used on an acoustic source (such as a drum kit) and an upsampled plug-in is used on one of the mic channels but not the other, without input delay compensation, the phase of the two mic channels would no longer be aligned.

How Console IDC works

Console IDC automatically adds small amounts of delay to each Console input that is *not* delayed by upsampled plug-ins, so all Console inputs are still phase aligned. In other words, all compensated inputs are automatically delayed by the same amount.

Upsampled UAD plug-ins

Some UAD plug-ins are *upsampled*, meaning their internal sample rate is increased to achieve sonic design goals. When upsampled UAD plug-ins are used in Console, additional latency is induced in the channel(s) using the plug-in(s).

Although the latency added by upsampled UAD plug-ins is negligible (typically between 0-300 samples, depending on the plug-in and sample rate), this extra latency can affect phase coherency in a session.

Upsampled Latency Values

For a chart of specific upsampling latency values for UAD plug-ins, see the [UAD Plug-Ins Manual](#).

When To Use Console Input Delay Compensation

Console IDC is required to maintain phase alignment only when **BOTH** of the following conditions are active:

1. Multiple Console inputs are used for a single source (such as a drum kit using multiple microphones), and
2. Any of those input channels contain upsampled UAD plug-ins.

***Tip:** When IDC is not needed, disable Console IDC for the lowest possible input latency.*

Effect of Console's IDC setting

In Console

In Console, the amount of delay added by the IDC engine is automatic. Only the minimum amount of delay actually required to compensate the input(s) is applied (up to the maximum value of the setting), maintaining the lowest possible latency for phase alignment at all times.

For example: When the IDC value is Short (100 samples – the default value) and only 31 samples is actually required to compensate, then only 31 samples of delay will be applied to the other Console inputs.

In the DAW

In the DAW, the amount of delay added by Console's IDC engine is static. The extra samples are always added to all inputs in the DAW, even if no upsampled plug-ins are active. However, this overall additional input latency is reported by Apollo's drivers, so it is automatically compensated by the DAW's ADC.

Input Delay Compensation Values	
Setting Name	Extra Delay (samples)
Off	0
Short	100
Medium	200
Long	1000

For example: When the IDC value is Short (100 samples – the default value) and only 31 samples is actually required to compensate, 100 samples is still added to all inputs in the DAW. If using software monitoring via the DAW, the extra (unnecessary) delay could be detected.

***Note:** By default, Console Input Delay Compensation is enabled with the Short value (100 samples).*

Software monitoring with Console IDC

When software monitoring via the DAW and Console IDC is enabled, the lowest effective Console IDC setting is recommended to minimize monitoring latency. If using Console for monitoring and software monitoring via the DAW is disabled, the IDC value isn't as critical because Console will dynamically deliver the lowest possible monitoring latency.

UAD-2 DSP Resources

Console IDC uses a small percentage of Apollo's UAD-2 DSP. To maximize DSP resource availability for UAD plug-ins, disable Console IDC if it is not needed.

Special Cases: UAD Precision Multiband and UAD Ampex ATR-102

These two upsampled UAD plug-ins have extra latency values that exceed the capacity of Console's IDC engine even at the maximum setting (Long). These plug-ins are designed to be used on outputs of a DAW during mixdown, where latency is not a consideration. If using these plug-ins in Console, the Input Delay Compensation feature may need to be disabled or ignored.

Latency Basics

Latency (delay) is an inherent factor in digital audio systems because of A/D-D/A conversion, I/O buffering in the DAW, plug-in signal processing, and other aspects.

Although there are ways to mitigate latency (such as delay compensation and/or low-latency monitoring), it always exists to some degree when working with systems that combine analog and digital audio. These concepts are explained in greater detail below.

Audio Interface Latency

Every audio interface that performs A/D and/or D/A conversion induces latency as a result of the conversion process. This inherent A/D–D/A latency is essentially undetectable. A/D–D/A latency usually depends on the sample rate, with higher sample rates inducing less latency (higher rates = less time required for conversion).

An audio interface’s “analog I/O round-trip latency” specification refers to how long it takes for an analog signal at an interface input to reappear at the same interface’s analog output after both A/D and D/A conversion. Apollo’s audio interface analog I/O round-trip latency is 1.1 milliseconds at a sample rate of 96 kHz.

Console Mixer Latency

Apollo’s Console Mixer is used for low-latency monitoring (cue mixing) of Apollo’s analog and digital inputs. Using Console to monitor Apollo’s inputs may or may not add to the inherent analog I/O round-trip latency, depending on how it is configured:

Console without UAD plug-ins – When Console is used without UAD plug-ins, monitoring Apollo’s inputs via Console does not add any latency. In this configuration, Apollo’s analog I/O round-trip latency is still 1.1 milliseconds at 96 kHz.

Console with Realtime UAD Processing – When Console is used for Realtime UAD Processing with UAD Powered Plug-Ins that are not upsampled, monitoring Apollo’s inputs via Console *does not add any latency*.

In this configuration, Apollo’s analog I/O round-trip latency is still 1.1 milliseconds at 96 kHz, even if up to four UAD (non-upsampled) plug-ins are serially “stacked” (chained) on a single Apollo analog and/or digital input.

Multiple Apollo inputs can have up to four UAD (non-upsampled) plug-ins each (up to the limit of available DSP resources); this configuration also *does not add any latency*.

Note: *Upsampled UAD plug-ins add latency when used in Console or a DAW. See [Upsampled UAD plug-ins](#) below for details.*

Console Auxiliary Buses – The outputs of the auxiliary buses in Console have 32 samples of additional latency. This is necessary to maintain the lowest possible input latency.

Upsampled UAD Plug-Ins

Some UAD Powered Plug-Ins are *upsampled*, meaning their internal sample rate is increased to achieve sonic design goals. Depending on the session sample rate, upsampled UAD plug-ins can add additional latency when used in the Console Mixer and/or a DAW.

Although the latency added by upsampled UAD plug-ins is negligible (typically between 0-300 samples, depending on the plug-in and sample rate), this extra latency can affect phase coherency in a session. However, phase is managed automatically by [Input Delay Compensation in Console](#) and [Automatic Delay Compensation in the DAW](#).

Note: For specific upsampling latency values for UAD plug-ins, see the [UAD Plug-Ins Manual](#).

DAW Latency

Most DAWs use I/O buffering to shuttle audio data back and forth between the audio interface and the DAW. This I/O buffering induces additional latency with any audio interface (not just Apollo).

I/O Buffer Size

The amount of DAW latency is usually determined by the DAW's I/O interface *buffer size* setting. Low buffer sizes reduce latency, but increase the host computer's CPU loading. If the buffer size is set too low, host CPU overloads and/or audio artifacts such as clicks, distortion, or dropouts can occur.

Monitoring Live Performance During Recording

DAW latency can be a problem during recording when “software monitoring” via the DAW's mixer, because the buffering delay is a distraction; an artist cannot hear their performance in realtime. DAW latency when recording with Apollo is mitigated by using the Console Mixer for live performance monitoring, where buffering latency does not apply.

Time-Alignment Of Newly-Recorded Tracks With Previously-Recorded Tracks

Dealing with latency is also important with DAWs for time-alignment of newly-recorded tracks and previously-recorded tracks which are inevitably shifted from the I/O buffering process.

The solution is to use the automatic delay compensation (“ADC”) feature of the DAW. Most modern DAWs, including Console, have automatic delay compensation. For more information about system latency and its compensation, see [“Delay Compensation with Apollo” on page 178](#).

UAD-2 DSP Latency

When UAD Powered Plug-Ins are used within a DAW (not Console), I/O buffering is used to shuttle audio data back and forth between the UAD-2 inside Apollo and the DAW, which induces additional latency.

This UAD-2 DSP “DAW processing method” latency is determined by the [I/O Buffer Size](#) setting. This latency is unrelated to the (indiscernible) audio interface I/O latency (they are separate processes).

UAD-2 DSP latency makes tracking through UAD plug-ins in the DAW via software monitoring problematic for the performer because again, an artist cannot hear their performance in realtime.

The issue of UAD-2 DSP latency when recording with Apollo is eliminated by using the Console Mixer for live performance monitoring with optional Realtime UAD Processing, where buffering latency does not apply.

Does all this latency stuff really matter?

With Apollo, not really. Performance latency is not a factor because of Console’s low latency hardware monitoring; and recording (track alignment) latency during recording, overdubbing, and mixing is automatically compensated by Console and the DAW.

Chapter 12: Device Drivers

Apollo Drivers Overview

The Apollo device drivers are the low-level software files that instruct the computer's operating system on how to communicate with the Apollo hardware. The drivers are loaded during system startup so that whenever Apollo is connected, the device is ready to accept instructions from the OS. Apollo's drivers control Apollo's audio interface, Console, and UAD-2 functionality.

Core Audio

Apollo's audio drivers use the Core Audio [APIs](#). Apollo's normal (non-DSP) audio interface features are simply seen as a Core Audio device; therefore any Core Audio-compliant software can use Apollo for audio I/O.

UAD Mixer Engine

The Console application and Console Recall plug-in don't actually communicate directly with Apollo. Instead, they communicate with the *UAD Mixer Engine*, which is the central software hub for all Console and Console Recall functionality. The UAD Mixer Engine behaves as a server for Apollo's internal DSP mixer that runs in the background, so Console does not have to be open for Apollo to function.

The UAD Mixer Engine is a system-level application that is automatically launched during system startup and is always running during normal operation. The UAD System Menu is its only interface, which can be accessed from its blue "UA diamond" icon in the OS X Menu Bar (at upper right of screen).

Driver I/O Complement

The specific inputs and outputs that are available to the DAW depends on the active configuration. The I/O complement changes at high sample rates and when multi-unit cascading. The specific I/O complements can be customized in the [Core Audio Panel](#). Default I/O values are listed in the [Driver I/O Tables](#) in this chapter.

Driver Names and Numbers

Apollo's drivers describe all I/O channels by name and number, but what is actually displayed in the DAW's I/O assignment lists depends on each particular DAW. Names are not displayed by all DAWs (e.g., Ableton Live), or the driver name display mode may need to be changed in the DAW (e.g., Apple Logic Pro).

Virtual I/O

Apollo's device drivers carry various *virtual* (software only) input and output channels in addition to those directly associated with the hardware inputs and outputs. The virtual channels consist of all of Apollo's bus outputs (the main monitor mix and all channel send mixes) and Console's virtual inputs. Virtual I/O facilitates highly flexible signal routing via the DAW. See "[Virtual I/O](#)" on [page 169](#) for details about this feature.

Driver I/O Tables

The tables in this section list the I/O numbers and names for all Core Audio streams available at default [Core Audio Panel](#) settings.

Note: All available driver I/O channels and names are also listed within Apple's Audio MIDI Setup application which is included with Mac OS X at: `/Applications/Utilities/Audio MIDI Setup.app`

Tip: Each table is on a single page. For convenient reference with DAWs that don't display driver I/O channels by name, print the sheet for your particular setup.

Available Tables

Click an Apollo model to jump directly to its table.

Apollo Twin Default I/O (ADAT Mode)	Apollo, Apollo 8 Default I/O
Apollo Twin Default I/O (S/PDIF Mode)	Apollo, Apollo 8 Default I/O (4x Rates)
Apollo 8p Default I/O (ADAT Mode)	Apollo 16, Apollo 16 mkII Default I/O
Apollo 8p Default I/O (4x Rates, ADAT Mode)	Apollo 16, Apollo 16 mkII Default I/O (4x Rates)
Apollo 8p Default I/O (S/PDIF Mode)	

Custom I/O Routes

The default I/O routes can be easily changed in the [Core Audio Panel](#) within the [Console Settings Window](#) window. See the [Flex Driver Overview](#) for details.

Driver I/O Table Notes

- The number in the left column is the channel number used by the DAW.
- All tables apply at all sample rates unless “4x Sample Rates” is noted.
- “1x sample rates” is defined as 44.1 kHz and 48 kHz.
- “2x sample rates” is defined as 88.2 kHz and 96 kHz.
- “4x sample rates” is defined as 176.4 kHz and 192 kHz.
- Channels listed as “N/A” are not available in the DAW. However, these routes can be easily reassigned in the [Core Audio Panel](#) to be made available in the DAW.
- With multi-unit setups, inputs marked with the symbol “†” are available on the designated monitor unit only. They are not available on any expander units.

Apollo Twin Default I/O (ADAT Mode)

Apollo Twin Default I/O Table Digital Input Mode: ADAT			
INPUTS		OUTPUTS	
1	ANALOG 1	1	MON L
2	ANALOG 2	2	MON R
3	MON L*	3	LINE 3
4	MON R*	4	LINE 4
5	VIRTUAL 1*	5	VIRTUAL 1*
6	VIRTUAL 2*	6	VIRTUAL 2*
7	VIRTUAL 3*	7	VIRTUAL 3*
8	VIRTUAL 4*	8	VIRTUAL 4*
9	ADAT 1	9	HP L
10	ADAT 2	10	HP R
11	ADAT 3		
12	ADAT 4		
13	ADAT 5		
14	ADAT 6		
15	ADAT 7		
16	ADAT 8		
17	AUX1 L*		
18	AUX1 R*		
19	AUX2 L*		
20	AUX2 R*		
<i>*Software Outputs (for DAW inputs)</i>		<i>*Software Inputs (for Console inputs)</i>	

Apollo Twin ADAT Input Channels and Sample Rates

The ADAT digital input recognizes the following channels and sample rates:

- Channels 1 – 8 at 44.1 kHz and 48 kHz
- Channels 1 – 4 at 88.2 kHz and 96 kHz
- Channels 1 – 2 at 176.4 kHz and 192 kHz

Apollo Twin Default I/O (S/PDIF Mode)

Apollo Twin Default I/O Table Digital Input Mode: S/PDIF			
INPUTS		OUTPUTS	
1	ANALOG 1	1	MON L
2	ANALOG 2	2	MON R
3	MON L*	3	LINE 3
4	MON R*	4	LINE 4
5	VIRTUAL 1*	5	VIRTUAL 1*
6	VIRTUAL 2*	6	VIRTUAL 2*
7	VIRTUAL 3*	7	VIRTUAL 3*
8	VIRTUAL 4*	8	VIRTUAL 4*
9	S/PDIF L	9	HP L
10	S/PDIF R	10	HP R
11	AUX1 L*		
12	AUX1 R*		
13	AUX2 L*		
14	AUX2 R*		
*Software Outputs (for DAW inputs)		*Software Inputs (for Console inputs)	

Note: Apollo Twin recognizes S/PDIF digital input at sample rates up to 96 kHz.

Apollo, Apollo 8 Default I/O

Apollo, Apollo 8 Driver Default I/O Table			
INPUTS		OUTPUTS	
1	MIC/LINE/Hi-Z 1	1	MON L
2	MIC/LINE/Hi-Z 2	2	MON R
3	MIC/LINE 3	3	LINE 1
4	MIC/LINE 4	4	LINE 2
5	LINE 5	5	LINE 3
6	LINE 6	6	LINE 4
7	LINE 7	7	LINE 5
8	LINE 8	8	LINE 6
9	ADAT 1	9	LINE 7
10	ADAT 2	10	LINE 8
11	ADAT 3	11	ADAT 1
12	ADAT 4	12	ADAT 2
13	ADAT 5	13	ADAT 3
14	ADAT 6	14	ADAT 4
15	ADAT 7	15	ADAT 5
16	ADAT 8	16	ADAT 6
17	S/PDIF L	17	ADAT 7
18	S/PDIF R	18	ADAT 8
19	VIRTUAL 1*	19	S/PDIF L
20	VIRTUAL 2*	20	S/PDIF R
21	VIRTUAL 3*	21	VIRTUAL 1*
22	VIRTUAL 4*	22	VIRTUAL 2*
23	VIRTUAL 5*	23	VIRTUAL 3*
24	VIRTUAL 6*	24	VIRTUAL 4*
25	VIRTUAL 7*	25	VIRTUAL 5*
26	VIRTUAL 8*	26	VIRTUAL 6*
27	MON L* †	27	VIRTUAL 7*
28	MON R* †	28	VIRTUAL 8*
29	AUX1 L* †	29	CUE1 L
30	AUX1 R* †	30	CUE1 R
31	AUX2 L* †	31	CUE2 L
32	AUX2 R* †	32	CUE2 R
		33	CUE3 L (N/A)
		34	CUE3 R (N/A)
		35	CUE4 L (N/A)
		36	CUE4 R (N/A)
<i>* Software Outputs (for DAW inputs)</i>		<i>*Software Inputs (for Console inputs)</i>	
<i>† In multi-unit setups, available on monitor unit only</i>			

Apollo, Apollo 8 Default I/O (4x Rates)

Apollo, Apollo 8 Driver Default I/O Table 4x Sample Rates			
INPUTS		OUTPUTS	
1	MIC/LINE/Hi-Z 1	1	MON L
2	MIC/LINE/Hi-Z 2	2	MON R
3	MIC/LINE 3	3	LINE 1
4	MIC/LINE 4	4	LINE 2
5	LINE 5	5	LINE 3
6	LINE 6	6	LINE 4
7	LINE 7	7	LINE 5
8	LINE 8	8	LINE 6
9	ADAT 1	9	LINE 7
10	ADAT 2	10	LINE 8
11	ADAT 3	11	ADAT 1
12	ADAT 4	12	ADAT 2
13	ADAT 5 (N/A)	13	ADAT 3
14	ADAT 6 (N/A)	14	ADAT 4
15	ADAT 7 (N/A)	15	ADAT 5 (N/A)
16	ADAT 8 (N/A)	16	ADAT 6 (N/A)
17	S/PDIF L	17	ADAT 7 (N/A)
18	S/PDIF R	18	ADAT 8 (N/A)
19	VIRTUAL 1* (N/A)	19	S/PDIF L
20	VIRTUAL 2* (N/A)	20	S/PDIF R
21	VIRTUAL 3* (N/A)	21	VIRTUAL 1* (N/A)
22	VIRTUAL 4* (N/A)	22	VIRTUAL 2* (N/A)
23	VIRTUAL 5* (N/A)	23	VIRTUAL 3* (N/A)
24	VIRTUAL 6* (N/A)	24	VIRTUAL 4* (N/A)
25	VIRTUAL 7* (N/A)	25	VIRTUAL 5* (N/A)
26	VIRTUAL 8* (N/A)	26	VIRTUAL 6* (N/A)
27	MON L* †	27	VIRTUAL 7* (N/A)
28	MON R* †	28	VIRTUAL 8* (N/A)
29	AUX1 L* †	29	CUE1 L
30	AUX1 R* †	30	CUE1 R
31	AUX2 L* † (N/A)	31	CUE2 L
32	AUX2 R* † (N/A)	32	CUE2 R
		33	CUE3 L (N/A)
		34	CUE3 R (N/A)
		35	CUE4 L (N/A)
		36	CUE4 R (N/A)
<i>*Software Outputs (for DAW inputs)</i>		<i>*Software Inputs (for Console inputs)</i>	
<i>† In multi-unit setups, available on monitor unit only</i>			

Apollo 8p Default I/O (ADAT Mode)

Apollo 8p Driver Default I/O Table			
Digital I/O Mode: ADAT			
INPUTS		OUTPUTS	
1	MIC/LINE/Hi-Z 1	1	MON L
2	MIC/LINE/Hi-Z 2	2	MON R
3	MIC/LINE 3	3	LINE 1
4	MIC/LINE 4	4	LINE 2
5	MIC/LINE 5	5	LINE 3
6	MIC/LINE 6	6	LINE 4
7	MIC/LINE 7	7	LINE 5
8	MIC/LINE 8	8	LINE 6
9	ADAT 1	9	ADAT 1
10	ADAT 2	10	ADAT 2
11	ADAT 3	11	ADAT 3
12	ADAT 4	12	ADAT 4
13	ADAT 5	13	ADAT 5
14	ADAT 6	14	ADAT 6
15	ADAT 7	15	ADAT 7
16	ADAT 8	16	ADAT 8
17	VIRTUAL 1*	17	VIRTUAL 1*
18	VIRTUAL 2*	18	VIRTUAL 2*
19	VIRTUAL 3*	19	VIRTUAL 3*
20	VIRTUAL 4*	20	VIRTUAL 4*
21	VIRTUAL 5*	21	VIRTUAL 5*
22	VIRTUAL 6*	22	VIRTUAL 6*
23	VIRTUAL 7*	23	VIRTUAL 7*
24	VIRTUAL 8*	24	VIRTUAL 8*
25	MON L* †	25	CUE1 L
26	MON R* †	26	CUE1 R
27	AUX1 L* †	27	CUE2 L
28	AUX1 R* †	28	CUE2 R
29	AUX2 L* †	29	CUE3 L (N/A)
30	AUX2 R* †	30	CUE3 R (N/A)
		31	CUE4 L (N/A)
		32	CUE4 R (N/A)
* Software Outputs (for DAW inputs)		*Software Inputs (for Console inputs)	
† In multi-unit setups, available on monitor unit only			

Apollo 8p Default I/O (4x Rates, ADAT Mode)

Apollo 8p Driver Default I/O Table 4x Sample Rates, ADAT Mode			
INPUTS		OUTPUTS	
1	MIC/LINE/Hi-Z 1	1	MON L
2	MIC/LINE/Hi-Z 2	2	MON R
3	MIC/LINE 3	3	LINE 1
4	MIC/LINE 4	4	LINE 2
5	MIC/LINE 5	5	LINE 3
6	MIC/LINE 6	6	LINE 4
7	MIC/LINE 7	7	LINE 5
8	MIC/LINE 8	8	LINE 6
9	ADAT 1	9	ADAT 1
10	ADAT 2	10	ADAT 2
11	ADAT 3	11	ADAT 3
12	ADAT 4	12	ADAT 4
13	ADAT 5 (N/A)	13	ADAT 5 (N/A)
14	ADAT 6 (N/A)	14	ADAT 6 (N/A)
15	ADAT 7 (N/A)	15	ADAT 7 (N/A)
16	ADAT 8 (N/A)	16	ADAT 8 (N/A)
17	VIRTUAL 1* (N/A)	17	VIRTUAL 1* (N/A)
18	VIRTUAL 2* (N/A)	18	VIRTUAL 2* (N/A)
19	VIRTUAL 3* (N/A)	19	VIRTUAL 3* (N/A)
20	VIRTUAL 4* (N/A)	20	VIRTUAL 4* (N/A)
21	VIRTUAL 5* (N/A)	21	VIRTUAL 5* (N/A)
22	VIRTUAL 6* (N/A)	22	VIRTUAL 6* (N/A)
23	VIRTUAL 7* (N/A)	23	VIRTUAL 7* (N/A)
24	VIRTUAL 8* (N/A)	24	VIRTUAL 8* (N/A)
25	MON L* †	25	CUE1 L
26	MON R* †	26	CUE1 R
27	AUX1 L* †	27	CUE2 L
28	AUX1 R* †	28	CUE2 R
29	AUX2 L* † (N/A)	29	CUE3 L (N/A)
30	AUX2 R* † (N/A)	30	CUE3 R (N/A)
		31	CUE4 L (N/A)
		32	CUE4 R (N/A)
<i>*Software Outputs (for DAW inputs)</i>		<i>*Software Inputs (for Console inputs)</i>	
<i>† In multi-unit setups, available on monitor unit only</i>			

Apollo 8p Default I/O (S/PDIF Mode)

Apollo 8p Driver Default I/O Table			
Digital I/O Mode: S/PDIF			
INPUTS		OUTPUTS	
1	MIC/LINE/Hi-Z 1	1	MON L
2	MIC/LINE/Hi-Z 2	2	MON R
3	MIC/LINE 3	3	LINE 1
4	MIC/LINE 4	4	LINE 2
5	MIC/LINE 5	5	LINE 3
6	MIC/LINE 6	6	LINE 4
7	MIC/LINE 7	7	LINE 5
8	MIC/LINE 8	8	LINE 6
9	S/PDIF L	9	S/PDIF L
10	S/PDIF R	10	S/PDIF R
11	VIRTUAL 1*	11	VIRTUAL 1*
12	VIRTUAL 2*	12	VIRTUAL 2*
13	VIRTUAL 3*	13	VIRTUAL 3*
14	VIRTUAL 4*	14	VIRTUAL 4*
15	VIRTUAL 5*	15	VIRTUAL 5*
16	VIRTUAL 6*	16	VIRTUAL 6*
17	VIRTUAL 7*	17	VIRTUAL 7*
18	VIRTUAL 8*	18	VIRTUAL 8*
19	MON L* †	19	CUE1 L
20	MON R* †	20	CUE1 R
21	AUX1 L* †	21	CUE2 L
22	AUX1 R* †	22	CUE2 R
23	AUX2 L* †	23	CUE3 L (N/A)
24	AUX2 R* †	24	CUE3 R (N/A)
		25	CUE4 L (N/A)
		26	CUE4 R (N/A)
* Software Outputs (for DAW inputs)		*Software Inputs (for Console inputs)	
† In multi-unit setups, available on monitor unit only			

Note: Apollo 8p recognizes S/PDIF digital I/O at sample rates up to 96 kHz.

Apollo 16, Apollo 16 mkII Default I/O

Apollo 16, Apollo 16 mkII Driver Default I/O Table			
INPUTS		OUTPUTS	
1	LINE 1	1	MON L
2	LINE 2	2	MON R
3	LINE 3	3	LINE 1
4	LINE 4	4	LINE 2
5	LINE 5	5	LINE 3
6	LINE 6	6	LINE 4
7	LINE 7	7	LINE 5
8	LINE 8	8	LINE 6
9	LINE 9	9	LINE 7
10	LINE 10	10	LINE 8
11	LINE 11	11	LINE 9
12	LINE 12	12	LINE 10
13	LINE 13	13	LINE 11
14	LINE 14	14	LINE 12
15	LINE 15	15	LINE 13
16	LINE 16	16	LINE 14
17	AES/EBU L	17	LINE 15
18	AES/EBU R	18	LINE 16
19	VIRTUAL 1*	19	AES/EBU L
20	VIRTUAL 2*	20	AES/EBU R
21	VIRTUAL 3*	21	VIRTUAL 1*
22	VIRTUAL 4*	22	VIRTUAL 2*
23	VIRTUAL 5*	23	VIRTUAL 3*
24	VIRTUAL 6*	24	VIRTUAL 4*
25	VIRTUAL 7*	25	VIRTUAL 5*
26	VIRTUAL 8*	26	VIRTUAL 6*
27	MON L* †	27	VIRTUAL 7*
28	MON R* †	28	VIRTUAL 8*
29	AUX1 L* †	29	CUE1 L
30	AUX1 R* †	30	CUE1 R
31	AUX2 L* †	31	CUE2 L
32	AUX2 R* †	32	CUE2 R
		33	CUE3 L (N/A)
		34	CUE3 R (N/A)
		35	CUE4 L (N/A)
		36	CUE4 R (N/A)
<i>*Software Outputs (for DAW inputs)</i>		<i>*Software Inputs (for Console inputs)</i>	
<i>† In multi-unit setups, available on monitor unit only</i>			

Apollo 16, Apollo 16 mkII Default I/O (4x Rates)

Apollo 16, Apollo 16 mkII Driver Default I/O Table 4x Sample Rates			
INPUTS		OUTPUTS	
1	LINE 1	1	MON L
2	LINE 2	2	MON R
3	LINE 3	3	LINE 1
4	LINE 4	4	LINE 2
5	LINE 5	5	LINE 3
6	LINE 6	6	LINE 4
7	LINE 7	7	LINE 5
8	LINE 8	8	LINE 6
9	LINE 9	9	LINE 7
10	LINE 10	10	LINE 8
11	LINE 11	11	LINE 9
12	LINE 12	12	LINE 10
13	LINE 13	13	LINE 11
14	LINE 14	14	LINE 12
15	LINE 15	15	LINE 13
16	LINE 16	16	LINE 14
17	AES/EBU L	17	LINE 15
18	AES/EBU R	18	LINE 16
19	VIRTUAL 1* (N/A)	19	AES/EBU L
20	VIRTUAL 2* (N/A)	20	AES/EBU R
21	VIRTUAL 3* (N/A)	21	VIRTUAL 1* (N/A)
22	VIRTUAL 4* (N/A)	22	VIRTUAL 2* (N/A)
23	VIRTUAL 5* (N/A)	23	VIRTUAL 3* (N/A)
24	VIRTUAL 6* (N/A)	24	VIRTUAL 4* (N/A)
25	VIRTUAL 7* (N/A)	25	VIRTUAL 5* (N/A)
26	VIRTUAL 8* (N/A)	26	VIRTUAL 6* (N/A)
27	MON L* †	27	VIRTUAL 7* (N/A)
28	MON R* †	28	VIRTUAL 8* (N/A)
29	AUX1 L* †	29	CUE1 L
30	AUX1 R* †	30	CUE1 R
31	AUX2 L* † (N/A)	31	CUE2 L
32	AUX2 R* † (N/A)	32	CUE2 R
		33	CUE3 L (N/A)
		34	CUE3 R (N/A)
		35	CUE4 L (N/A)
		36	CUE4 R (N/A)
<i>*Software Outputs (for DAW inputs)</i>		<i>*Software Inputs (for Console inputs)</i>	
<i>† In multi-unit setups, available on monitor unit only</i>			

Chapter 13: Glossary

A/D An acronym for “Analog to Digital,” which refers to the conversion of analog signals to digital data.

Acronym A word formed from the first letters of other words (e.g., GUI, ADAT, TRS, etc.).

ADAT An acronym for “Alesis Digital Audio Tape.” ADAT was the name given to the Alesis-branded products of the 1990s which recorded eight tracks of digital audio on a standard S-VHS video cassette. The term now generally refers to the 8-channel optical “Lightpipe” connection that is used in a wide range of digital products from many manufacturers.

AES (sometimes written as “AES/EBU”) The name of a digital audio transfer standard jointly developed by the American-based Audio Engineering Society and the European Broadcast Union. Designed to carry two channels of 16-, 20- or, 24-bit digital audio at sampling rates of up to 192kHz, the most common AES physical interconnect utilizes a 3-conductor 110 ohm twisted pair cable, terminating at standard XLR connectors. (See “Dual Wire” and “Single Wire”)

Analog Literally, an analog is a replica or representation of something. In audio signals, changes in voltage are used to represent changes in acoustic sound pressure. Note that analog audio is a continuous representation, as opposed to the quantized, or discrete “stepped” representation created by digital devices. (See “Digital”)

API Acronym for Application Programming Interface. A software layer between an operating system and third-party hardware (such as an audio interface) and/or software (such as a DAW). For example, a computer OS’s audio API enables audio hardware and audio software from different vendors to communicate with the OS and each other.

Apollo Expanded Universal Audio’s name for connecting more than one Apollo device together via Thunderbolt in a multi-unit cascading setup for increased I/O.

ASIO Acronym for Audio Stream Input/Output. ASIO is an audio interface driver protocol for Windows operating systems developed by Steinberg GmbH.

Balanced Audio cabling that uses two twisted conductors enclosed in a single shield, thus allowing relatively long cable runs with minimal signal loss and reduced induced noise such as hum.

Bit A contraction of the words “binary” and “digit,” a bit is a number used in a digital system, and it can have only one of two values: 0 or 1. The number of bits in each sample determines the theoretical maximum dynamic range of the audio data, regardless of sample rate being used. Each additional bit adds approximately 6 dB to the dynamic range of the audio. In addition, the use of more bits helps capture quieter signal more accurately. (See “Sample” and “Dynamic range”)

Bit Depth (See “Bit Resolution”)

Bit Resolution Often used interchangeably with “bit depth,” this is a term used to describe the number of bits used in a digital recording. Apollo converts analog audio and transmits digital audio with a resolution of 24 bits (thus yielding a theoretical dynamic range of approximately 145 dB), the highest audio interface resolution in common use today. (See “Dynamic Range”)

BNC A bayonet-type coaxial connector often found on video and digital audio equipment, as well as on test devices like oscilloscopes. In digital audio equipment, BNC connectors are normally used to carry word clock signals between devices. BNC connectors are named for their type (Bayonet), and their inventors, Paul Neil and Carl Concelman. (See “Word Clock”)

Buffer, buffers, buffering The transference of data in small batches instead of continuously. Buffering induces latency (delay) and is inherent in most digital audio systems.

Bus A signal path that carries more than one signal, e.g., a mix bus, auxiliary bus, headphone cue bus, etc.

Channel Input Strip A group of controls that pertain only to the functions contained within a particular mixer input channel. In most mixing consoles, the “strips” are duplicated for each input.

Class A One design technique used in electronic devices such that their active components are drawing current and working throughout the full signal cycle, thus yielding a more linear response. This increased linearity results in fewer harmonics generated, hence lower distortion in the output signal.

Condenser Microphone A microphone design that utilizes an electrically charged thin conductive diaphragm stretched close to a metal disk called a backplate. Incoming sound pressure causes the diaphragm to vibrate, in turn causing the capacitance to vary in a like manner, which causes a variance in its output voltage. Condenser microphones tend to have excellent transient response but require an external voltage source, most often in the form of 48 volts of “phantom power.”

Clock In digital audio or video, a clock serves as a timing reference for a system. Every digital device must carry out specified numbers of operations per period of time and at a consistent speed in order for the device to work properly. Digital audio devices such as Apollo normally have an internal clock, and are also capable of locking to external clock routed from other digital devices. In order to avoid signal degradation or undesirable audible artifacts, it is absolutely critical that all digital devices that are interconnected in a system be locked to the same clock.

Clock Distribution Refers to the process of routing a master clock signal (either from an internal clock or an external source) to multiple devices by means of multiple outputs, thus removing the need to cascade the clock through external devices, which can degrade the signal.

Core Audio The audio [API](#) for Mac OS X.

D/A Acronym for “Digital to Analog,” which refers to the conversion of a digital data to an analog signal.

DAW Acronym for “Digital Audio Workstation” – that is, any device that can record, play back, edit, and process digital audio.

dB Abbreviation for “decibel,” a logarithmic unit of measure used to determine, among other things, power ratios, voltage gain, and sound pressure levels.

dBm Abbreviation for “decibels as referenced to milliwatt,” dissipated in a standard load of 600 ohms. 1 dBm into 600 ohms results in 0.775 volts RMS.

dBV Abbreviation for “decibels as referenced to voltage,” without regard for impedance; thus, one volt equals one dBV.

DI Acronym for “Direct Inject” or “Direct Input,” a recording technique whereby the signal from a high-impedance instrument such as electric guitar or bass is routed to an input. DI into mixer or tape recorder inputs often employ use of a “DI box,” which raises the signal to the correct voltage level at the right impedance.

Digital Information or data that is stored or communicated as a series of bits (binary digits, with values of 0 or 1). Digital audio refers to the representation of varying sound pressure levels by means of a series of numbers. (See “Analog” and “Bit”)

Dither Minute amounts of shaped noise added intentionally to a digital recording in order to reduce a form of distortion known as “quantization noise” and aid in low level sound resolution.

Dry Refers to a signal that is unprocessed, e.g., recording a dry signal. The antonym of a “wet” signal.

DSP Acronym for “Digital Signal Processing” (or “Digital Signal Processor.”)

DSP Accelerator A device dedicated to digital signal processing. UAD-2 devices are DSP accelerators.

Dynamic Microphone A type of microphone that generates signal with the use of a very thin, light diaphragm which moves in response to sound pressure. That motion in turn causes a voice coil which is suspended in a magnetic field to move, generating a small electric current. Dynamic mics are generally less expensive than condenser or ribbon mics and do not require external power to operate.

Dynamic Range The difference between the loudest sections of a piece of music and the softest ones. The dynamic range of human hearing (that is, the difference between the very softest passages we can discern and the very loudest ones we can tolerate) is considered to be approximately 120 dB. (See “Bit resolution”)

EQ Abbreviation for “Equalization,” a circuit that allows selected frequency areas in an audio signal to be attenuated or boosted.

External Clock A clock signal derived from an external source. (See “Clock”)

FET Acronym for “Field Effect Transistor.” A type of transistor that relies on an electric field to control the shape, and hence the conductivity, of a “channel” in a semiconductor material.

Firmware Software that is embedded in hardware.

Flex Driver Apollo technology that enables customized I/O mapping at the Core Audio driver level.

Flex Routing Apollo technology that enables its physical inputs to be routed to various physical outputs. Compare to Virtual I/O.

FPGA Acronym for “Field Programmable Gate Array.” A type of integrated circuit that can be programmed after manufacturing (“in the field”) to perform specialized functions.

Front End Refers to a device that provides analog and digital input/output (I/O) to a digital audio workstation (DAW). Apollo is a front end.

Graphical User Interface A software window, panel, or screen containing controls where parameters are adjusted by the user. (See “GUI”)

GUI Acronym for Graphical User Interface.

Hi-Z Abbreviation for “High Impedance.” Apollo’s Hi-Z input allows direct connection of an instrument such as electric guitar or bass via a standard unbalanced ¼” jack.

High Resolution In digital audio, refers to 24-bit signals at sampling rates of 88.2 kHz or higher.

Hz Abbreviation for “Hertz,” a unit of measurement describing a single analog audio cycle (or digital sample) per second.

Impedance A description of a circuit’s resistance to a signal, as measured in ohms, thousands of ohms (Kilohms), or millions of ohms (megohms).

Internal Clock A clock signal derived from onboard circuitry. (See “Clock”)

I/O Acronym for “input/output.”

kHz Abbreviation for “kiloHertz” (a thousand Hertz), a unit of measurement describing a thousand analog audio cycles (or digital samples) per second. (See “Hz”)

JFET Acronym for Junction Field Effect Transistor, a specific type of FET which has some similarities to traditional bipolar transistor designs that can make it more appropriate for use in some audio circuit designs. (See “FET”)

Jitter Refers to short-term variations in the edges of a clock signal, caused by a bad source clock, inferior cabling or improper cable termination, and/or signal-induced noise. A jittery signal will contain spurious tones at random, inharmonic frequencies. Usually, the jitter will be worse with higher signal frequencies. The internal digital clock of Apollo was designed for extreme stability and jitter-free operation, and its onboard phase aligned clock conditioner circuitry removes jitter from external sources, so conversion quality is unaffected by clock source.

Lightpipe A digital connection made with optical cable. This was a phrase coined by Alesis to make a distinction between the proprietary 8-channel optical network used in their ADAT products and standard stereo optical connectors used on CD players and other consumer products.

Line Level Refers to the voltages used by audio devices such as mixers, signal processors, tape recorders, and DAWs. Professional audio systems typically utilize line level signals of +4 dBm (which translates to 1.23 volts), while consumer and semiprofessional audio equipment typically utilize line level signals of -10 dBV (which translates to 0.316 volts).

Low Cut Filter An equalizer circuit that cuts signal below a particular frequency. Same as “high pass filter.”

Mic Level Refers to the very low level signal output from microphones, typically around 2 millivolts (2 thousandths of a volt).

Mic Preamp The output level of microphones is very low and therefore requires specially designed mic preamplifiers to raise (amplify) their level to that needed by a mixing console, tape recorder, or digital audio workstation (DAW).

Mute “Turn off the signal.” Mute stops the signal from being routed.

Native Refers to computer-based digital audio recording software controlled by the computer’s onboard processor, as opposed to software that requires external hardware to run.

OS Acronym for Operating System. The OS is the software used to control the computer hardware, such as OS X (Mac) and Windows (PC).

Pan Abbreviation for “Panorama” or “Panoramic.” A pan control determines a monophonic signal’s positioning in the stereo field.

Patch Bay A passive, central routing station for audio signals. In most recording studios, the line-level inputs and outputs of all devices are connected to a patch bay, making it an easy matter to re-route signal with the use of patch cords.

Patch Cord A short audio cable with connectors on each end, typically used to interconnect components wired to a patch bay.

PDF Acronym for “Portable Document Format.” PDF is the standardized file format used for distribution of documentation in electronic form. Various applications can open PDF files; one such “reader” application is available for free at www.adobe.com.

Plug-In Software components that are added to host software applications to enhance their functionality and/or performance.

Powered Plug-Ins High-quality audio processing plug-ins, developed and sold by Universal Audio, that run exclusively on UAD DSP accelerator products.

Quantization Noise A form of digital distortion caused by mathematical rounding-off errors in the analog to digital conversion process. Quantization noise can be reduced dramatically by dithering the digital signal. (See “Dither”)

Realtime UAD Processing Universal Audio's DSP + FPGA technology that enables UAD Powered Plug-Ins to run with latencies in the sub-2ms range. Realtime UAD processing provides the ultimate sonic experience while monitoring and/or tracking. Realtime UAD processing is a special function that is available only within the Console application.

Ribbon Microphone A type of microphone that works by loosely suspending a small element (usually a corrugated strip of metal) in a strong magnetic field. This "ribbon" is moved by the motion of air molecules and in doing so it cuts across the magnetic lines of flux, causing an electrical signal to be generated. Ribbon microphones tend to be delicate and somewhat expensive, but often have very flat frequency response.

Sample A digital "snapshot" of the amplitude of a sound at a single instant in time. The number of samples taken per second is determined by the device's sample rate. (See "Sample rate")

Sample Rate The number of samples per second. In digital audio, there are six commonly used sample rates: 44.1 kHz (used by audio CDs), 48 kHz, 88.2 kHz (2 x 44.1 kHz), 96 kHz (2 x 48 kHz, used by DVDs), 176.4 kHz (4 x 44.1 kHz), and 192 kHz (4 x 48 kHz). The higher the sample rate, the greater the frequency response of the resulting signal; however, higher sample rates require more storage space. (See "kHz")

Sample Rate Conversion The process of altering a digital signal's sample rate to a different sample rate.

S/MUX (sometimes written as "S-MUX") Abbreviation for Sample Multiplexing. S/MUX is a method for transmitting two channels of high sample rate (88.2, 96, 176.4, or 192 kHz) 24-bit digital audio over a legacy optical "lightpipe" ADAT connection, which was originally designed to carry eight channels of 16-, 20- or 24-bit audio at 44.1 kHz or 48 kHz sampling rate. (See "ADAT" and "Lightpipe")

SPDIF (sometimes written as "S/PDIF") An acronym for "Sony/Philips Digital Interface Format," a digital audio transfer standard largely based on the AES/EBU standard. Designed to carry two channels of 16-, 20- or 24-bit digital audio at sampling rates of up to 192 kHz, the most common SPDIF physical interconnect utilizes unbalanced, 75 ohm video-type coaxial cables terminating at phono (RCA-type) connectors. (See "AES")

Superclock A proprietary format used by some early Pro Tools systems to distribute clock signal running at 256x the system's sample rate, thus matching the internal timing resolution of the software. (See "Clock" and "Pro Tools")

Transcoding Converting one type of digital signal to another (i.e, from AES to SPDIF, or from ADAT to AES).

Transformer An electronic component consisting of two or more coils of wire wound on a common core of magnetically permeable material. Audio transformers operate on audible signal and are designed to step voltages up and down and to send signal between microphones and line-level devices such as mixing consoles, recorders, and DAWs.

Transient A relatively high volume pitchless sound impulse of extremely brief duration, such as a pop. Consonants in singing and speech, and the attacks of musical instruments (particularly percussive instruments), are examples of transients.

Transimpedance Preamp A transformerless solid-state preamplifier utilizing a transistor configuration that employs current feedback for ultra-low distortion and the highest possible quality of signal from input to output. The transimpedance design allows audio from 4 Hz to 150 kHz to pass through without altering the phase relationships between fundamental frequencies and overtones. Noise and distortion are kept to near-theoretical minimums so critical signals may be generously amplified without degrading the quality or character of the sound source.

TRS Acronym for Tip-Ring-Sleeve. A ¼” phone connector with three conductors, typically used for balanced signal connections (e.g., I/O) or carrying two unbalanced signals (e.g., headphones).

TS Acronym for Tip-Sleeve. A ¼” phone connector with two conductors, typically used for unbalanced signal connections. Note that TS, like TRS and XLR, denotes the connector only and does not necessarily indicate the signal level of the connection. TS/TRS/XLR cables are used for both low-level (e.g., microphones and instruments) and line-level connections.

UAD Acronym for “Universal Audio Digital.” Used in reference to digital products created by Universal Audio.

UAD-2 A line of DSP accelerator products developed and manufactured by Universal Audio.

Unison Universal Audio’s exclusive preamp hardware/software integration technology that enables UAD preamp plug-ins reconfigure the physical input impedance, gain staging response, and other parameters of Apollo’s mic preamp hardware to match the emulated preamp’s hardware design characteristics with bi-direction control.

Virtual I/O Apollo audio inputs and outputs that exist in software but not in hardware. Virtual I/O is used to route digital audio channels between Console and other audio applications. Compare to Flex Routing.

Wet Refers to a signal that is processed, e.g., recording a wet signal. The antonym of a “dry” signal.

Word Clock A dedicated clock signal based on the transmitting device’s sample rate or the speed with which sample words are sent over a digital connection. (See “Clock”)

XLR A standard three-pin connector used by many audio devices, with pin 1 typically connected to the shield of the cabling, thus providing ground. Pins 2 and 3 are used to carry audio signal, normally in a balanced (out of phase) configuration.

Chapter 14: Index

Symbols

48V 64

A

Accessing Apollo I/O via Core Audio 160
Accessing Apollo's I/O 165
ALT Monitoring Overview 38
Always On Top 135
Apollo as a digital mixer (without a DAW)
157
Apollo as an Audio Interface 160
Apollo Concurrently with a DAW and Console
167
Apollo Device Differences 44
Apollo I/O Driver Names 160
Apollo Setups Overview 157
Apollo System 6
Apollo with a DAW (without Console) 164
Apollo with Console (without a DAW) 162
Apollo Without A Computer 163
Application Menus 95
Audio Interface Latency 181
Automatic Delay Compensation in the DAW
178
Aux Fader 77
Auxiliary Section 75
Aux Inserts 76
Aux Meter 77
Aux Mono 77
Aux Mute 77
Aux Return Control Strips 75
Aux Returns 75

C

Channel Input Controls 62
Channel Strip Editor 102
Channel Strips Overview 29
Clip Hold Time 134
Clip & Peak Hold Settings 134
Clock Display 59
Close All Plug-In Editor Windows 98
Console Application 7, 11, 16, 45, 115
Console Functions 17
Console Mixer Latency 181
Console Overview 16
Console Recall Overview 140
Console Recall Plug-In 11, 140
Console Reference 45
Console Sessions 87
Console Settings Overview 32
Control Room Column 85
Controls Shortcuts 43
Core Audio 184
Cue Outputs Window 82
Cues Overview 34
Current Bank Overview 24
customer support 13

D

DAW Documentation 10
DAW Latency 182
Default Outputs 165
Delay Compensation 178
Device Drivers 8, 12, 178, 184
Driver Reporting 178
Drivers 184
Drivers Overview 184

F

Fader 70, 77
Fader Scale 70
Features 7
File Menu 95
Flex Driver Overview 39
Flex Routing 67

G

Global Settings 17
Global Window Elements 44
Glossary 195

H

Hardware installation 14
Hardware Monitoring 167
HPF 64

I

Identify 123
Info Bar Overview 28
Input Controls 62
Input Delay Compensation 178, 180
Input Mute 70
Input Types 29
Insert Effects Overview 33
Installation Overview 14
Interface Latency 181
Introduction 6
I/O Buffer Size 182
I/O Driver Names 160
I/O in Mac OS X System Preferences 161
I/O in the audio software application 160

K

Keyboard Shortcuts 44

L

Label 72
Latency Compensation 168
Level Hover 70
Level Scale 71, 77, 78
Link 74
Link Limitations 74
Low Cut Filter 64

M

Meter 77
Meter Bridge 45
Meter Bridge Overview 23
Meter Source 78
MIDI 58
Minimize 94
Mirror to Monitor 68
Monitor Column 78
Monitor Column Overview 27
Monitor Mix Controls 69
Monitor Mute 80
Monitor With FX 33
Mono 77
Multi-Unit Cascading 171
Mute 70, 77, 80

O

Outputs 165

P

Pan 69
Peak Hold Settings 134
Peak Hold Time 134
phase 64
Plug-In Inserts 65
Polarity 64
Preamp Controls 62
Preamp Inputs 29
Pre-Fader 134

R

Record With FX 33
Redo 96
Reference Level 64
Routing Console Outputs Into the DAW for Recording 168

S

- Sends Overview 35
- Sends Window 66
- Sessions Manager Window 89
- Settings 98
- Show Plug-In Editor Windows 98
- Software Features 7
- Software Monitoring 167
- Software Overview 11
- Software Updates 14
- Solo 69
- Standalone Use 163
- Synchronized DAW Sessions 143
- System Latency Overview 178
- System Requirements 14

T

- Technical Support 13

U

- UAD-2 DSP Latency 182
- UAD Meter & Control Panel 8
- UAD Mixer Engine 184
- UAD Plug-In Inserts Overview 31
- UAD Powered Plug-Ins 8, 11
- UAD Powered Plug-Ins Processing 158
- Undo 96
- Unison 144
- Unison Insert 63
- Upsampled UAD Plug-Ins 181
- Using Apollo Concurrently with a DAW and Console 167
- Using Apollo with a DAW (without Console) 164
- Using Apollo with Console (without a DAW) 162

V

- View Column 47
- View Column Overview 25
- View Options 51
- Virtual I/O 169

W

- Window Menu 134

Chapter 15: Notices

Disclaimer

The information contained in this manual is subject to change without notice. Universal Audio, Inc. makes no warranties of any kind with regard to this manual, including, but not limited to, the implied warranties of merchantability and fitness for a particular purpose. Universal Audio, Inc. shall not be liable for errors contained herein or direct, indirect, special, incidental, or consequential damages in connection with the furnishing, performance, or use of this material.

End User License Agreement

Your rights to the Software are governed by the accompanying End User License Agreement, a copy of which can be found at: www.uaudio.com/eula

Trademarks

Universal Audio, the Universal Audio “diamond” logo, Apollo, Apollo Twin, Apollo 16, Unison technology, UAD, UAD Series, UAD-1, UAD-2, UAD-2 Satellite, Powered Plug-Ins, 1176LN, 1176SE, Teletronix, LA-2A, LA-3A, LA-610, LA-610MkII, 2-1176, 2-610, 6176, 710 Twin-Finity, 2192, 4-710d, Cambridge EQ, DreamVerb, Plate 140, Precision Limiter, RealVerb Pro, Precision Buss Compressor, Precision De-Esser, Precision Maximizer, and “Analog Ears | Digital Minds,” are among the trademarks, trade names, and service marks owned by UA that may appear on the Site, many of which are registered in the United States and other countries. This is not a comprehensive list of all UA trademarks. All UA trademarks inure to the benefit of UA. Other trademarks and trade names that may appear on the Site and which are not owned by UA are owned by the respective owners.

Copyright

Copyright ©2015 Universal Audio, Inc. All rights reserved.

This manual and any associated software, artwork, product designs, and design concepts are subject to copyright protection. No part of this document may be reproduced, in any form, without prior written permission of Universal Audio, Inc.

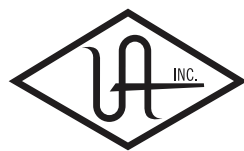

UNIVERSAL AUDIO

Universal Audio, Inc.
4585 Scotts Valley Drive
Scotts Valley, CA 95066 USA
Customer Service & Technical Support:
USA Toll-Free: +1-877-698-2834
International: +1-831-440-1176
www.uaudio.com