

MOOER

MODFACTORY PRO

DUAL ENGINE MODULATION PEDAL

Owner's Manual

Precautions

PLEASE READ CAREFULLY BEFORE PROCEEDING

Power Supply

Use the correct AC outlet to connect the power adapter. Use a power transformer with a negative external voltage of 9V ($\pm 10\%$) $\geq 300\text{mA}$, $\oplus \ominus \ominus$ otherwise it will cause equipment damage, fire or other problems. When unused or thunderstorms please unplug the power supply.

Connections

Before connecting the device or disconnecting it, be sure to turn off the power and other equipment, which will help to avoid malfunction and damage to other equipment. Also, make sure that all cables and power cords are disconnected before moving the unit.

Place the place

To prevent deformation, discoloration, and other serious damage, avoid the following:

- Direct sunlight
- Magnetic field
- Dusty or unclean place
- Strongly vibrating or shakin
- Near heat source
- High temperature and humidity
- Humidity is large

Electrical interference

When using the unit, the radio and the TV may cause interference. Use the unit away from the radio and the TV.

Clean

Please use a dry, soft cloth to clean the unit. If necessary, wipe with a slightly moist cloth. Do not use rough clean powder, alcohol, paint thinner, wax, solvent, detergent and chemical agents such as impregnated wipes.

Operating

Do not use brutal forces to use switches and control elements. Do not allow paper, metal, and other objects to fall into the machine. Be careful not to fall, do not subject it to shock and excessive pressure.

FCC certification

This device complies with Part 15 of the FCC Rules. Operation is subject to the following two conditions:

- This device may not cause harmful interference.
- This device must accept any interference received, including interference that may cause undesired operation.

Main Features

- 2 Independent processing modules containing a total of 16 modulation effects
- Adjustable signal chain routing
- Store and recall up to 4 user presets
- Tap Tempo functionality
- Expression pedal expandability
- Leslie style ACCELERATION pedal
- True stereo outputs

Pedal Layout

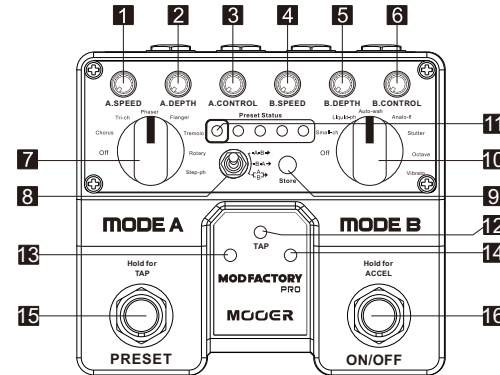

1. **A.SPEED**
Adjusts the rate of MODE A
2. **A.DEPTH**
Adjusts the depth/mix of MODE A

3. **A.CONTROL**
Adjusts various effect parameters of MODE A
4. **B.SPEED**
Adjusts the rate of MODE B
5. **B.DEPTH**
Adjusts the depth/mix of MODE B
6. **B.CONTROL**
Adjusts various effect parameters of MODE B
7. **MODE A**
Selects the effect type for MODE A
8. **ROUTING SWITCH**
Selects the internal signal chain routing (see ROUTING section of this manual)
9. **STORE**
Used for saving presets (see USING PRESETS section of this manual)
10. **MODE B**
Selects the effect type for MODE B
11. **PRESET STATUS LED**
Displays the currently selected Preset
12. **TAP TEMPO LED**
This LED will illuminate red when the PRESET FOOTSWITCH is controlling TAP TEMPO
13. **EFFECT SPEED LED**
Displays the current speed of the modulation rate
14. **ON/OFF LED**
Displays the ON/OFF status of the pedal
15. **PRESET**
 - Press this footswitch to scroll through presets
 - Press and hold this footswitch to activate/deactivate tap tempo
 - When tap tempo is activated, press this footswitch multiple times to control the speed of the modulation rate
16. **ON/OFF**
 - Press this footswitch to turn the pedal on/off
 - Press and hold this footswitch to activate effect acceleration

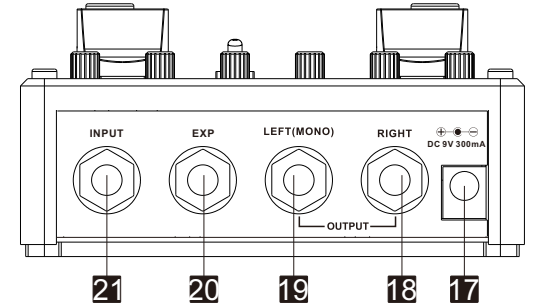

17. **DC IN**
Connect to a 9VDC power source
18. **RIGHT OUTPUT**
 - Connect to the input of your amplifier using a standard 1/4" jack cable
 - When used in stereo this output provides the Right Channel. When used in MONO this output provides DSP BYPASS
19. **LEFT OUTPUT**
 - Connect to the input of your amplifier using a standard 1/4" jack cable
 - When used in stereo this output provides the Left Channel. When used in MONO this output provides TRUE BYPASS
20. **EXP**
Connect to an external expression pedal using a 1/4" TRS stereo jack cable
21. **INPUT**
Connect to the output of your instrument using a standard 1/4" jack cable

Routing

MOD FACTORY PRO contains 2 independent Modulation modules (MODE A/MODE B) which can operate individually or simultaneously. The internal signal chain routing of the pedal can be adjusted using the ROUTING SWITCH.

1. Serial MODE A > MODE B

The signal will first go to MODE A and then to MODE B
When using this routing the TAP TEMPO controls the rate of MODE A



2. Serial MODE B > MODE A

The signal will first go to MODE B and then to MODE A
When using this routing the TAP TEMPO controls the rate of MODE B



3. PARRALLEL

- The signal will first be split into 2 and then go to MODE A and MODE B simultaneously
- The signal will then exit both effect modules and be mixed together before reaching the outputs of the pedal



- When using Parallel routing you can simulate a dry through WET/DRY setup by disabling one of the effect modules. To achieve this simply set either MODE A or MODE B to the 'Off' position.

- Try setting MODE A to 'Off' and 'MODE B' to Vibrato whilst in PARRALLEL routing to discover a very cool chorus type effect.



Using Presets

MOD FACTORY PRO can store 4 presets which can be scrolled through live using the PRESET footswitch. When you save a preset the pedal will store all of your parameter value, routing and expression pedal settings.

The PRESET STATUS LEDs display which preset is currently selected. When the RED LED is highlighted (on the far left) MOD FACTORY PRO is in pedal mode. This means that all parameter values will be equal to their respective controls physical position.

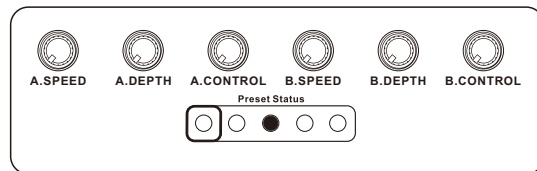

To scroll through presets, press and release the PRESET footswitch

To store a preset

- Make all settings you wish to save
- Press the STORE button once and the preset LED will begin to flash
- Select the preset space where you wish to store your settings by pressing the PRESET footswitch
- Press the STORE button one more time to confirm or move any control on the pedal to cancel the storage procedure

Connections

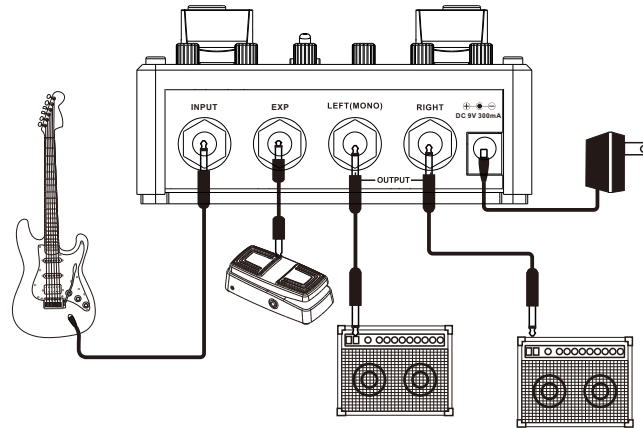

Expression Pedal

Expand the live performance experience of your MOD FACTORY PRO by using it with an expression pedal. The expression pedal can be set to control any one single parameter of the MOD FACTORY PRO.

- Connect your expression pedal to the EXP input of the MOD FACTORY PRO using a 1/4" trs stereo Jack cable.
- Simultaneously rotate the control knob of the parameter you wish to set to the EXP and rock the pedestal of your expression pedal back and forth
- Now you have successfully set the expression pedal to control a parameter of the MOD FACTORY PRO

Specifications

Input: 1/4" mono jack (impedance 1M Ohms)

Output: 1/4" mono jack x2 (impedance 100 Ohms)

Sampling rate: 44.1K

Sampling accuracy: 24bit

Power supply: 9V 300mA DC power supply (centre pin negative)

Power consumption: 250mA

Size: 106mm (D) X96mm (W) X53mm (H)

Weight: 400g

** Disclaimer: Specification update is subject to change without notice.*

MOOER

MOOER AUDIO CO.,LTD

www.mooeraudio.com

Part No:620010640