

Seattle Jazz Electric Guitar DIY Kit

Thank you for purchasing this DIY Guitar Kit. The following instructions specify how to assemble your guitar. There are a variety of finishes that can be applied to the guitar, and it is up to you to choose the style that best suits you. Information on how to apply the finishes are readily available on the internet. We recommend a little research to find your favoured finishing method.

All of our headstocks are provided 'uncut'. This gives you the opportunity to be creative and design your own, or copy one of the popular styles. For this, we recommend marking the shape out with a pencil, cutting the design with a Coping Saw or Jigsaw, and then finishing off with sandpaper. We have not supplied full instructions for this, as the process will depend on your individual design. Again, an internet search engine search will provide far more relevant instructions than we would be able to provide.

The guitar will need to be fully 'set-up' after construction. This is the process to make the guitar fully playable. Numerous video guides can be found online, and we recommend searching on popular video streaming sites. Alternatively, the guitar can be professionally set up by your local professional Luthier.

Before you start you will need to make sure you have the following tools to hand:

- Soldering Iron
- Cross Head Screwdriver - Medium Head
- Cross Head Screwdriver - Small Head
- Battery Powered Screwdriver (not essential but advised)
- Tape Measure or Ruler

The logo for gear4music features the text "gear4music" in a bold, rounded, sans-serif font. The number "4" is significantly larger than the other characters. Behind the text is a large, light grey gear icon with a human silhouette inside it, suggesting a focus on music and craftsmanship.

gear4music

Enjoy building your Guitar!

Contents



Parts

1. Body x 1
2. Neck x 1
3. Wires
4. Neck Pickup x 1
5. Bridge Pickup x 1
6. Scratchplate x 1
7. Tone Pot x 1
8. Volume Pot x 1
9. Output Jack x 1
10. Transistor x 1
11. Jack Washer x 1
12. Pot Nuts x 2
13. Tailpiece x 1
14. Bridge Pins x 2

15. Bridge x 1

16. Machine Heads x 6
17. Ferrules x 12
18. Washers x 6
19. Neck Plate x 1
20. Control Knobs x 2
21. Strings x 6
22. Tone Selector x 1

Screws

- 10mm x 8
- 12mm x 10
- 25mm x 9
- 35mm x 4
- 45mm x 4
- Springs x 4

Step 1

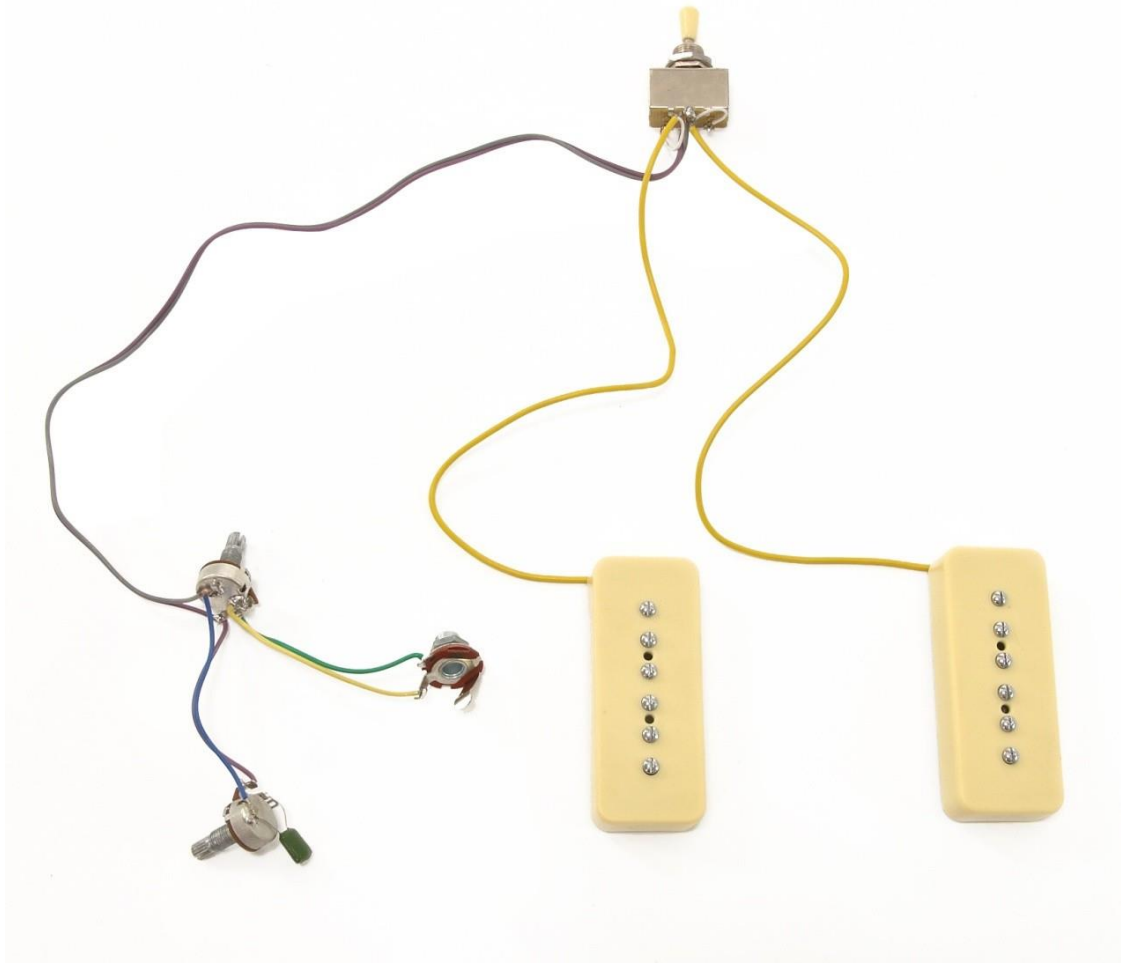

Please Note: Wire colour may differ from diagram

Separate the wires (3) in to pairs. Solder the uncovered wire of the Neck Pickup (4) to the body arm of the Tone Selector (22). Solder the covered wire to the right central arm of the Tone Selector. Solder the uncovered wire of the Bridge Pickup (5) to the body arm of the Tone Selector. Solder the covered wire to the left central arm of the Tone Selector. Solder the Grey cable of the long cable pair to the body arm of the Tone Selector. Solder the Purple cable of the long cable pair to the central arm of the Tone Selector.

Solder the Purple cable of the long cable pair to the first arm of the Volume Pot (8). The Grey cable of the long cable pair should be soldered to the back of the Volume Pot (8). The Green wire should be soldered from the second arm of the Volume Pot (8) to the long arm of the Jack Input (9). The yellow wire should be soldered from the back of the Volume Pot (8) to the short arm of the Jack Input (9). The third arm of the Volume Pot (8) should be soldered to the back of the pot.

Solder the Transformer (10) from the second arm of the Tone Pot (7) to the back of the Tone Pot. The short purple wire should be soldered from the third arm of the Tone Pot (7) to the first arm of the Volume Pot (8). The blue wire should be soldered from the back of the Tone Pot (7) to the back of the Volume Pot (8).

Step 2



Solder the red Earth Wire to the back of the Volume Pot (8), and feed through the hole in the body cavity to the Bridge Pin holes as pictured.

Attach the wiring to the Scratchplate (6). The Jack Input (9) should be secured using the Washer and Nut (11) and the Tone Pots should be secured using the Pot Nuts and Washers (12). The Scratchplate (6) should then be attached to the body (1) using the 10 x 12mm screws, lining them up with the pilot holes.

Place the pickups in the correct positions as pictured. Put the 4 x 45mm screws through the holes in the Pickups (4 and 5). Place the 4 screw on the screws underneath the pickups, and then screw the pickups into place.

Step 3



Screw the Tailpiece (13) in place, aligning it with the pilot holes, using the 7 x 25mm screws. Put the Bridge Pins (14) in the holes as pictured.



Step 4



Put the Body (1) and Neck (2) together. Place the Neck Plate (19) with the rubber Pad on the back of the Body (1) in line with the pilot holes, and attach with the 4x 45mm screws.

gear4music

Step 5



Insert the machine heads (16) in to the holes in the Headstock (2). Place the washer on top (18), and then screw in the Ferrules (17). The neck should then be turned over and the 6 x 10mm screws should be screwed into the pilot holes securing the machine heads in place.

String the guitar and then attach the String Trees to the Headstock using the 8mm screws and the small spacers. The larger spacer should be placed between the D and G strings, and the smaller spacer between the B and E strings.

gear4music

Step 6



Attach the Strap Buttons with their rubber washers to the pilot holes on the base and arm of the body using the 2x25mm screws. Place the Bridge (15) on top of the Bridge Pins (14) and then string the guitar using the provided strings (21).

gear4music

Congratulations, you have now completed the construction of your guitar.



gear4music

Appendix

Wiring Diagram

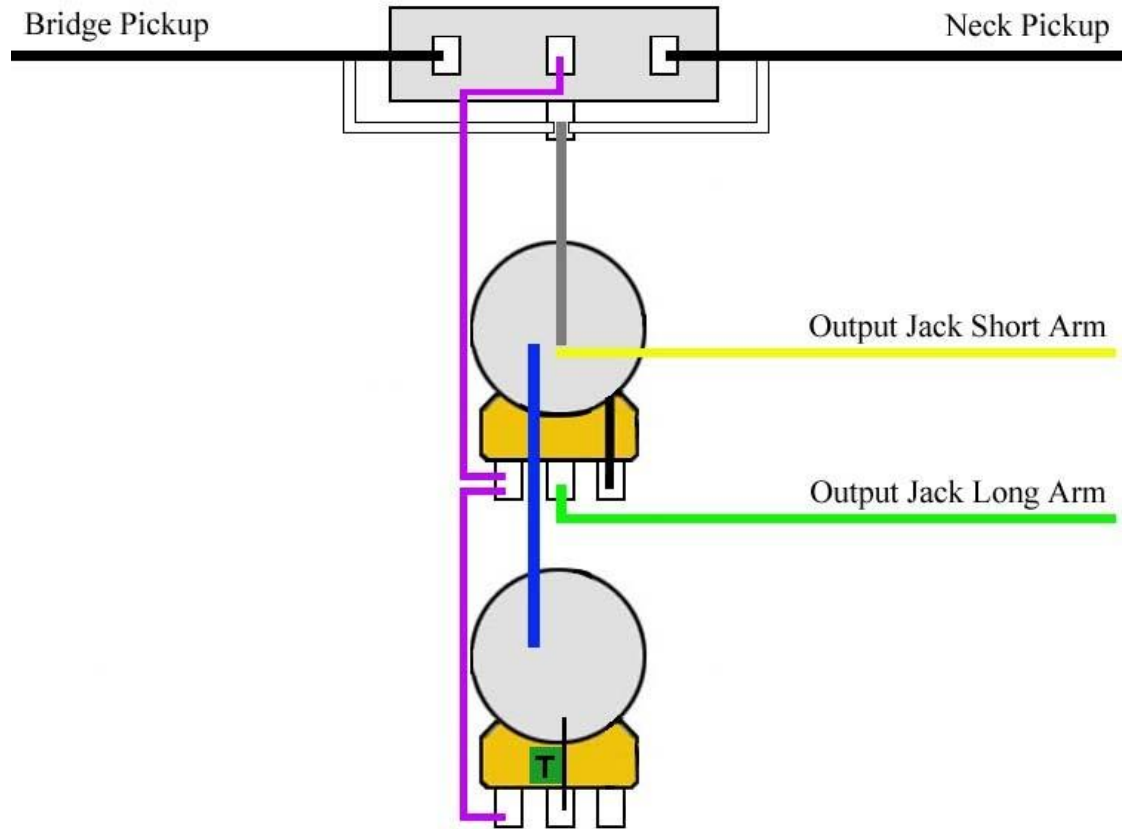

Please Note: Wire colour may differ from diagram

