

Zaor[®]

BUDGET CUSTOM DESIGN

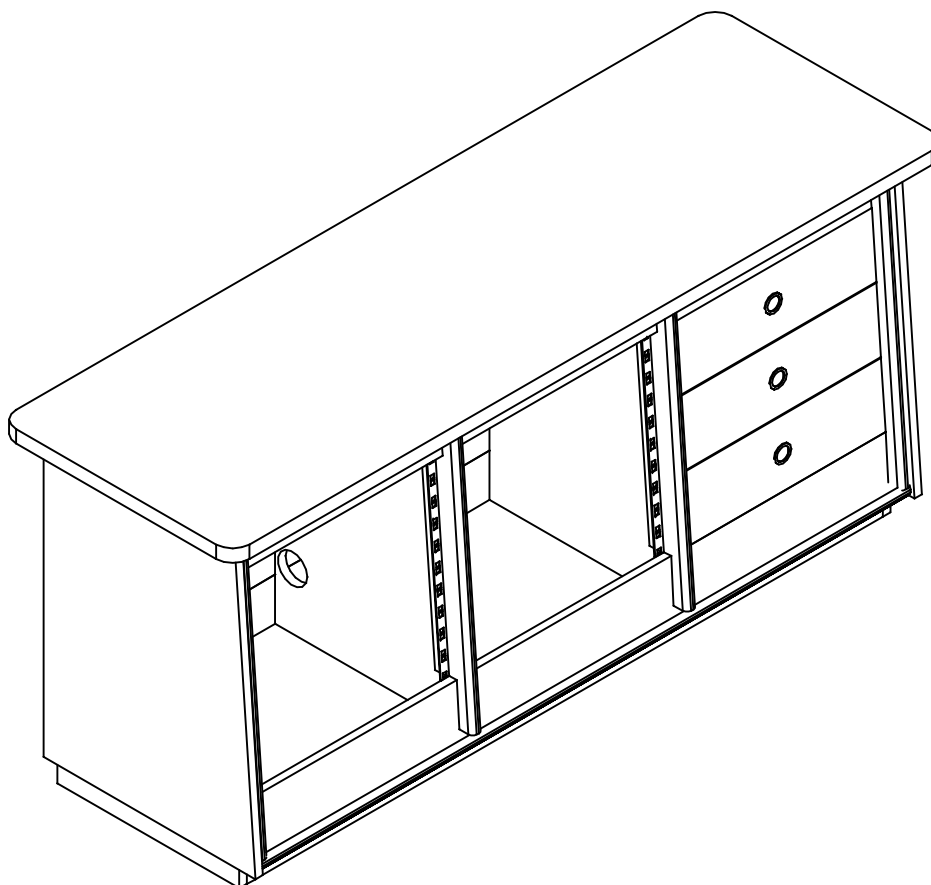

Rackboard

Assembly Manual

Assembly Manual

Thank you for choosing a piece of Zaor studio furniture,
which will hopefully make your life easier, more ergonomic and improve the looks of your workspace.

Before you can enjoy the comfort of your new acquisition you need to assemble it.

We have tried to give you as much detail as needed and as little as possible.

Should you run into any difficulty with this assembly you can get in touch with us via
sales@zaorstudiofurniture.com to set up a Skype session or phone call.

Here is a general instruction on how to use the furniture assembly kits:

- 1) Insert and screw in the system bolt(s) into the socket(s) already present on the panel(s)
- 2) Tighten ever so lightly, if using a screwdriver toward the end, do not turn more than 30°!
- 3) Assemble with the connecting panel, aligning the bolts with the round holes in the latter
- 4) Insert the eccentric connector(s) into the round hole(s) and tighten clockwise with a flat screwdriver or a 4mm Allen key (about 90°)



Expanding socket

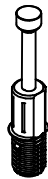

System bolt

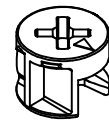

Eccentric fitting

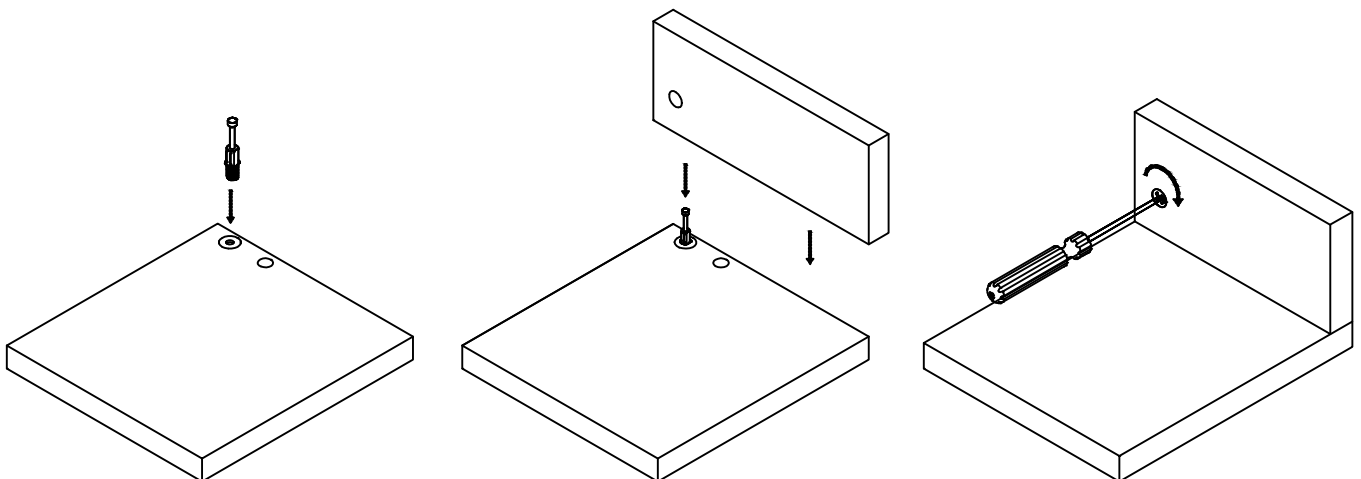

Assembly Manual

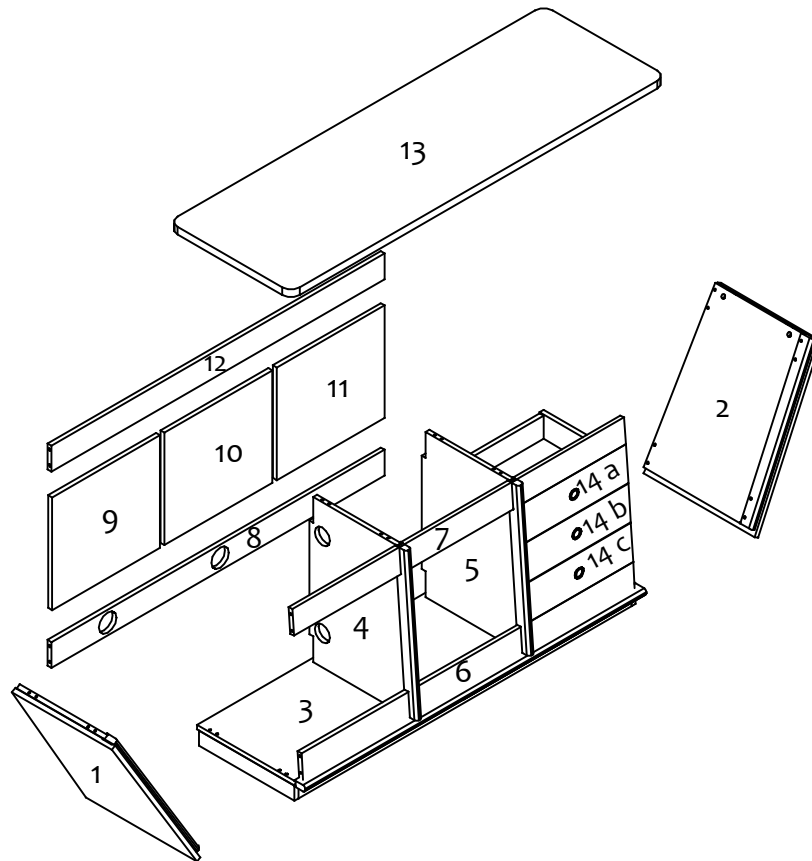

Pannello n° 1 laterale sinistro
Pannello n° 2 laterale destro

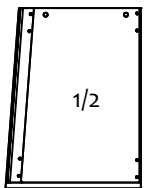

Pannello n° 3
base

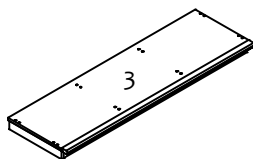

Pannelli n° 4-5
divisori

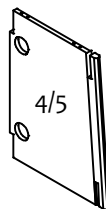

Pannelli n° 6-7
stabilizzatori frontali

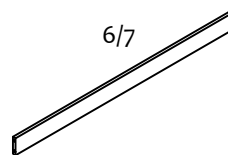

Pannello n°
stabilizzatore posteriore

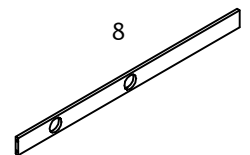

Pannelli n° 9-10-11
(tappi) chiusura posteriori

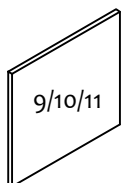

Pannello n° 12
stabilizzatore posteriore

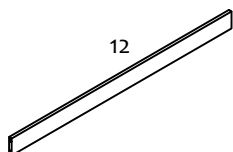

Pannello n° 13
tabletop

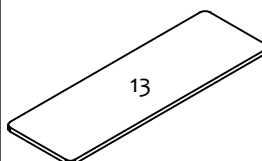

Elementi n° 14 a-b-c
cassetti

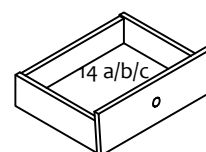

Pannello n° 10
laterale destro

Assembly Manual

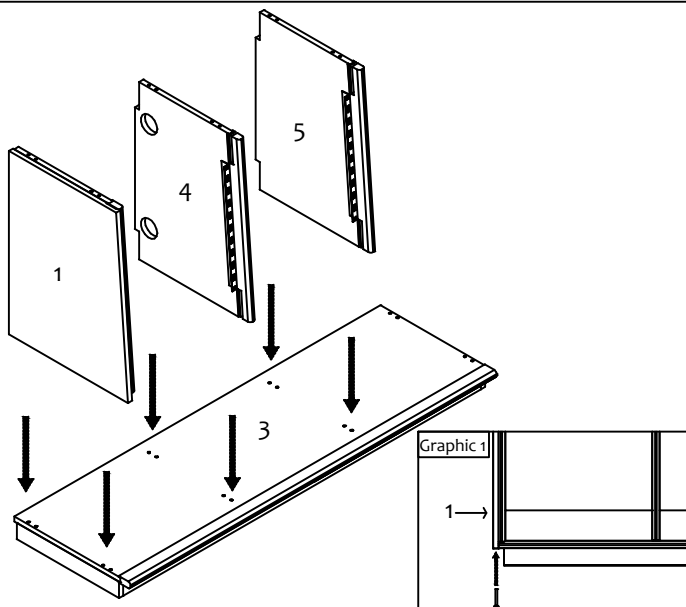

FASE 1

posizionare il pannello n° 3 orizzontalmente al suolo, dall'alto verso il basso accostare i pannelli n° 1, 4 e 5. Fissare il pannello n° 1 al n° 3 con viti M 6 x30 (grafico 1) e i pannelli n° 4 e 5 con i kit di giunzione montati precedentemente (vedi scheda montaggio kit).

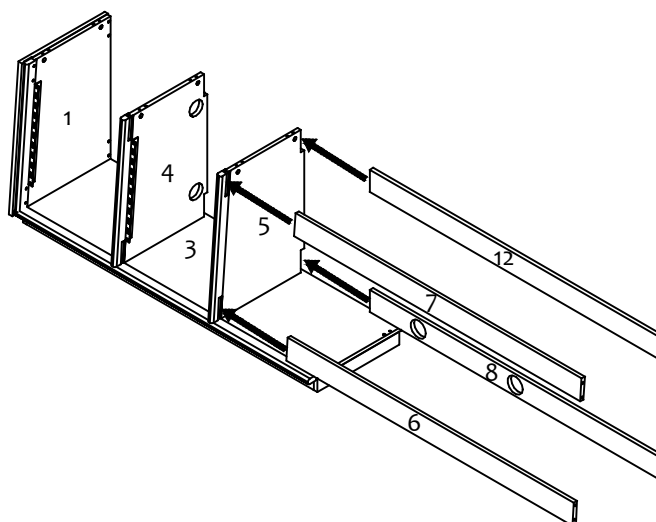

FASE 2

inserire i pannelli n° 6 e 7 nelle fresature predisposte sulla parte anteriore dei pannelli n° 4 e 5 facendoli scorrere in orizzontale da destra verso sinistra per fissarli al pannello n° 1. Ripetere per i pannelli 8 e 12 nella parte posteriore del mobile.

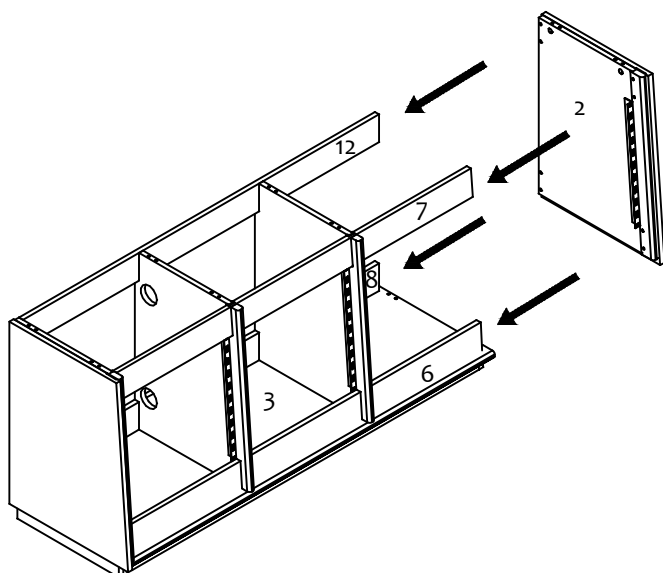

FASE 3

Fissare il pannello n° 2 prima ai pannelli n° 6,7,8 e 12. Successivamente fissare il pannello n° 2 al pannello n° 3 utilizzando le viti M 6x30 come fatto nella fase 1 (grafico 1).

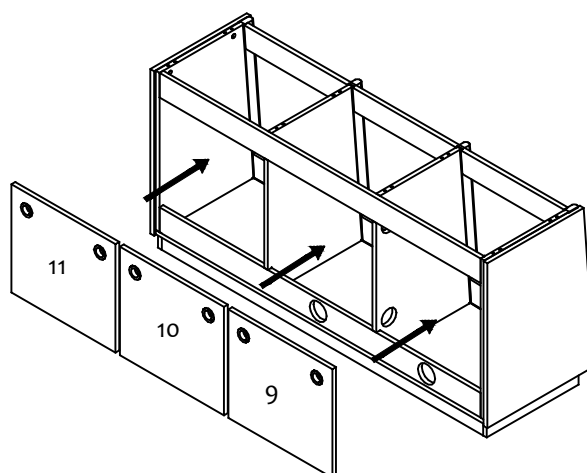

FASE 4

predisporre i tappi posteriori negli appositi vani nella parte posteriore del rackboard. Fissare utilizzando le viti esagonali.

Assembly Manual

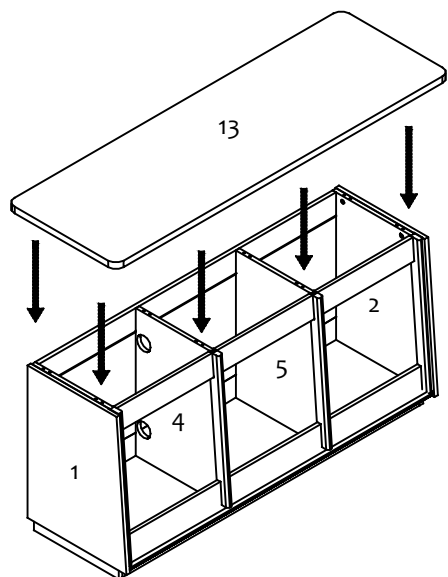

FASE 5

dall'alto verso il basso accostare il tabletop pannelli n° 13, fissare utilizzando i kit di giunzione.

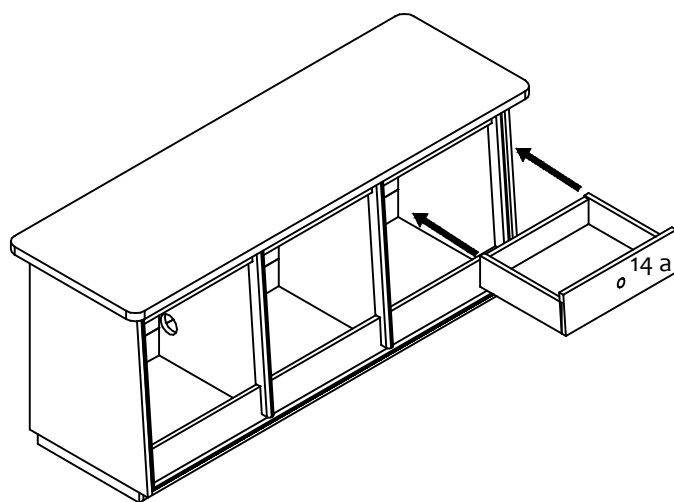

FASE 7

completare l'assemblaggio del rackboard inserendo i cassetti, elementi n° 14 a-b-c negli appositi vani. Evitare movimenti oscillatori laterali e non forzare.

Material used

- Melaminated chipboard
- Solid wood (Oak or Ash;

PACKING LIST

- N° 16 Assembly kits;
- N° 16 parts;
- N° 3 pre-assembled drawer;
- N° 80 kits rack;
- N° 8 viti M6x30;
- N° 12 viti M4x40;

Cleaning instructions

- clean with a soft, humid cloth or specific wood cleaners;
- avoid the use of abrasive materials or cleaners ;

We recommend being 2 people for assembly