

tc electronic®



The Dreamscape



USER'S MANUAL

Important Safety Instructions

- 1 Read these instructions.
- 2 Keep these instructions.
- 3 Heed all warnings.
- 4 Follow all instructions.
- 5 Do not use this apparatus near water.
- 6 Clean only with dry cloth.
- 7 Do not block any ventilation openings. Install in accordance with the manufacturer's instructions.
- 8 Do not install near heat sources such as radiators, heat registers, stoves, or other apparatus (including amplifiers) that produce heat.
- 9 Only use attachments/accessories specified by the manufacturer.
- 10 Refer all servicing to qualified service personnel. Servicing is required when the apparatus has been damaged in any way, e.g. when the power-supply cord or the plug has been damaged, liquid has been spilled or objects have fallen into the apparatus, the apparatus has been exposed to rain or moisture, does not operate normally, or has been dropped.

Warning!

- To reduce the risk of fire or electrical shock, do not expose this equipment to dripping or splashing and ensure that no objects filled with liquids, such as vases, are placed on the equipment.
- Do not install in a confined space.

Service

- All service must be performed by qualified personnel.

Caution:

You are cautioned that any change or modifications not expressly approved in this manual could void your authority to operate this equipment.

When replacing the battery follow the instructions on battery handling in this manual carefully.

EMC/EMI

This equipment has been tested and found to comply with the limits for a Class B Digital device, pursuant to part 15 of the FCC rules.

These limits are designed to provide reasonable protection against harmful interference in residential installations. This equipment generates, uses and can radiate radio frequency energy and – if not installed and used in accordance with the instructions – may cause harmful interference to radio communications. However, there is no guarantee that interference will not occur in a particular installation. If this equipment does cause harmful interference to radio or television reception – which can be determined by turning the equipment off and on –, the user is encouraged to try correcting the interference by one or more of the following measures:

- Reorient or relocate the receiving antenna.
- Increase the separation between the equipment and the receiver.
- Connect the equipment to an outlet on a circuit different from the one to which the receiver is connected.
- Consult the dealer or an experienced radio/TV technician for help.

For the customers in Canada:

This Class B digital apparatus complies with Canadian ICES-003. Cet appareil numérique de la classe B est conforme à la norme NMB-003 du Canada.

Introduction

Congratulations on the purchase of John Petrucci's signature pedal "The Dreamscape"!

John Petrucci was one of the first artists to join our revolutionary TonePrint concept. In total, John created 5 personal TonePrints in early 2011 – two for Corona Chorus, two for Shaker Vibrato and one for Vortex Flanger. John loved having access to all effect parameters so much that he instantly agreed when TC suggested collaborating on the development of a signature pedal – one that was based on his own TonePrints. And so **The Dreamscape** was born.

Basically, John wanted to gather all of his TonePrints in a single pedal even though his original TonePrints are for three different pedals in the series. Therefore, his new signature pedal contains no less than three mind-blowing modulation effects that have been painstakingly tailored with an eye for even the tiniest detail by the master himself. To take this pedal over the top, John even created a brand new TonePrint for Vortex Flanger, taking the total amount of custom-tweaked tones up to six: 2 x Chorus, 2 x Flanger and 2 x Vibrato.

On top of that, The Dreamscape also features a TonePrint mode that makes it compatible with any TonePrint for the Corona chorus pedal.



- 1 - Effect on/off (true bypass)
- 2 - ¼ inch mono jack input
- 3 - ¼ inch mono jack input (for stereo in)
- 4 - ¼ inch mono jack output
- 5 - ¼ inch mono jack output (for stereo out)
- 6 - FX level control
- 7 - Speed control
- 8 - Voice Selector – Bright / Normal / Dark
- 9 - Depth control
- 10 - Effect type selector
- 11 - Power in (9 VDC)
- 12 - USB connection for uploading TonePrint settings and software updates.

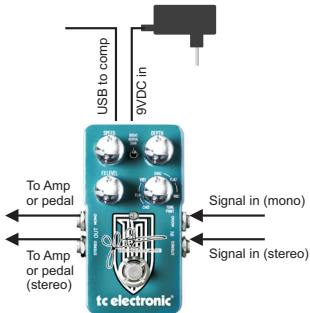

Connecting

Input jacks – Use MONO for mono input and both MONO and STEREO inputs if connecting a stereo source. If the pedal runs on battery, we recommend removing the mono input jack to preserve battery power when you don't play.

Output jacks – Connect to another pedal or directly into an amp or mixer. Use MONO for mono setups and both MONO and STEREO for stereo setups. Note that it is possible to select between true bypass and buffered bypass mode via a dip switch located under the battery cover.

Power in – Use a 9 VDC power supply with the following symbol: 

USB

Connect to a computer using the supplied USB cable for upload of **TonePrint settings**. The connector-type is Mini-B.

The controls

FX LEVEL

Controls the effects level. Please note that the direct signal is always passed at the original level (unity gain).

SPEED

The SPEED knob sets the speed of the chorus/flanger/vibrato – from slow, smooth and sparkly to much more pronounced “Leslie” types at high speeds, depending on the selected effect type.

DEPTH

DEPTH sets the range of the modulation. Experiment with both the SPEED and DEPTH controls to achieve the effect you are looking for.

BRIGHT / NORMAL / DARK selector

This selector gives you three options for each sound. The Bright option makes the selected effect very obvious whereas the Dark option makes the effect more subtle. Normal equals neutral.

EFFECT TYPE selector

Select between six John Petrucci modulation TonePrints and TonePrint mode. Any Corona Chorus TonePrint can be loaded into the Dreamscape pedal and is selected when this selector is set to TonePrint.

Chorus

“for clean sounds”

John’s clean chorus sound is legendary. Having used the SCF pedal for all chorusing duties ever since Dream Theater’s debut album, John has very specific demands for his clean Chorus TonePrint: It must have that classic TC Electronic shimmer, and although the Chorus should be very predominant, it shouldn’t get in the way of the original guitar tone. John chose the Tri-Chorus mode for this TonePrint as the three chorus lines “masks” the very obvious modulation sound of a traditional chorus. Set Depth and Speed to the 12 o’clock position and crank FX Level and Tone to get John’s favorite clean chorus tone.

Flanger

“for clean sounds”

For the clean Vortex flange sound, John opted for a type of phase cancellation that doesn’t completely cancel out, but sums the clean and effected signal into a warmer, swirly sound. John wanted this flange sound to be close to a “chorussy” type-sound. Recommended settings: Set all knobs to the 12 o’clock position for the standard TonePrint – and then adjust according to taste.

Vibrato

“for clean sounds”

John asked for a clear, swirly Leslie-type sound with just a little feedback. The result is a very wide Vibrato with a low speed rate at default knob positions. During the session, John was so inspired by the sound that he wrote a new riff right on the spot. Recommended settings: Set all knobs to the 12 o'clock position for the standard TonePrint – and then adjust according to taste.

Chorus 2

“for crunch sounds”

John is famous for using chorus on some of Dream Theater's crushing crunchy riffs. Originally inspired by the great Alex Lifeson from Rush, John's goal was to fatten up the sound without it getting too processed. To achieve that goal, John used the tri-chorus with some fairly subtle settings to get that almost-doubled sound.

Flanger 2

“for crunch sounds”

This is John's twist on a classic aggressive slow flanger. Twist the knobs to create numerous cool sounds, but try setting the knobs to the 12 o'clock position for that classic flange that works especially well on crunchy to heavy riffs. Kick this in on you signature rock riffs – and heads will turn.

Vibrato 2

“for crunch sounds”

John envisioned a Vibrato that was not too warbly and ended up with a subtle, almost doubling type of effect with a rich and fat tone, without the sound getting too dark or the effect getting too pronounced. John is happy with the result and stated during the session that this vibrato toneprint is “even cool on chords”.

TonePrint – the concept

Consider the knobs and switches on your pedal as a few handles that actually control a large number of parameters. TC Electronic staff has defined the controls – but wouldn't it just be cool to let the world's leading guitar players contribute with their own definition of how the controls should work? YES – this is what TonePrint is about. We allow top guitar players to dig out a pedal's hidden tonal potential, redefine the controls and make their own TonePrints. These TonePrints are available to you, and uploading TonePrints to your pedal is easy.

The Dreamscape is John Petrucci's signature pedal and provides six of his favorite modulation Toneprints – but you can also download any Corona Chorus TonePrint made by any artist. To recall this downloaded TonePrint, set the Effect Type selector to TonePrint.

- TonePrints can easily be transferred to your pedal either using the free TonePrint app for smartphones or via a direct connection to a Windows PC or Mac using the supplied USB cable.



While uploading a TonePrint you **MUST** have a 9V battery in the pedal or power connected to the pedal's power input. You **MUST** also have a jack cable plugged into the pedal's INPUT.

Please visit www.tcelectronic.com/toneprints for more information.

Bypass modes and Kill-Dry on/off

Unscrew the backplate and look for the two small DIP switches in the upper left corner. The upper DIP switch (the one closer to the DC 9V in connector) switches between True Bypass mode (default) and Buffered Bypass mode.

True Bypass

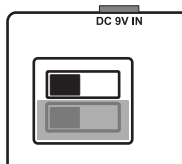

Buffered Bypass

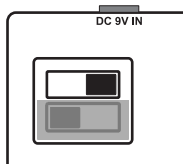

Kill-Dry – off

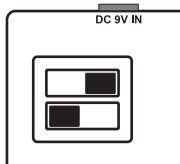

Kill-Dry – on

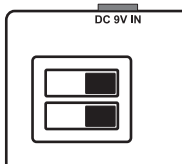

True Bypass is a hard-wire bypass, ensuring there is absolutely no tone coloration when the pedal is bypassed. Using True Bypass on all pedals is the perfect choice for setups with a few pedals and relatively short cables going to and coming from the pedals.

Buffered Bypass – If you use a long cable between your guitar and the first pedal, or if you use many pedals on your board, or if you use a long cable from your board to the amp, then the best solution will most likely be to activate the buffer both in the first and the last pedal in the signal chain.

Can you hear the difference between a pedal in True Bypass or Buffered Bypass mode? Maybe, maybe not – many factors apply: active/passive pick-ups, single coil/humbucker, cable quality, amp impedance and more. Accordingly, we cannot give a definitive answer here. Use your ears and find the best solution for your setup!

Kill-Dry on/off – With Buffered Bypass activated (upper DIP switch to the right), the lower DIP switch can be used to set Kill-Dry on or off. Kill-Dry removes all direct signal from the pedal's output. This is the mode to use when the pedal is placed in a parallel effects loop.

Changing the battery – Unscrew the thumbscrew on the back of the pedal and detach the backplate. Unmount the old battery and attach the new battery to the battery clip, making sure the polarity is correct. Then remount the backplate. To prolong battery life, remove the cable from the input jack when you're not using the pedal.



Batteries must never be heated, taken apart or thrown into fire or water. Only rechargeable batteries can be recharged. Remove the battery when the pedal is not being used for a longer period of time. Dispose batteries according to local laws and regulations.

Technical Specifications

Sounds	6 signature TonePrint from John Petrucci. Access to any Corona Chorus TonePrint
Size & Weight	72 mm x 122 mm x 50 mm – 300 g (excl. battery)
Battery	Dual Supply Rails technology ensures headroom for line level effect loops from a single 9V battery. Battery failure circuit automatically puts the Dreamscape pedal into true bypass mode if the battery runs out.
Design	Custom “hammerhead” rugged, die-cast aluminum casing built for a life on the road Unique one-screw battery access for lightning fast battery changes
Connectors & Inputs/Outputs	Stereo inputs with automatic mono/stereo sensing – feed it any signal. Stereo outputs for that ultra-wide sounds. Mini USB connector for uploading custom TonePrints and software updates.
Knobs etc.	Speed, Depth, FX Level and Effect Type selector with high quality metal shaft potentiometers. Heavy duty tactile footswitch with true bypass for zero tone coloration.
In the box	USB cable for uploading TonePrints, TC Electronic Guitar Pamphlet, TC Electronic Sticker.

These specifications are subject to change without notice.

tc electronic[®]

*TC Electronic, Sindalsvej 34, DK-8240 Risskov
info@tcelectronic.com*