

# electro-harmonix

## FLANGER HOAX

### - OPERATING INSTRUCTIONS -

Congratulations on your purchase of the Electro-Harmonix Flanger Hoax! The Flanger Hoax is one of the most powerful modulation instruments ever designed. From shimmering static and active phasing to frequency adjustable flanging, you will find an exciting new palette of textures at your fingertips. The sheer number of variations available through both familiar and advanced modulation controls will present you with the ability to creatively shade as well as wildly animate your music in a way that really was never before possible at this price level. Your own creativity is your only limitation.

Connect your instrument or mixer's Effects Send Output to the Flanger Hoax's Input jack, and run a second cable from any or all of the three main outputs (Direct out, Blended out or Effect out). You will learn which outputs will serve your purposes the best in different situations. Hit the true bypass footswitch to activate, and get ready for a magically ethereal treat.

Please take a few minutes to familiarize yourself with the Flanger Hoax controls and how they work.

**WARNING:** Use only the 18VDC/500mA AC adapter supplied with the FLANGER HOAX. Do not use any other AC adapters. Using other AC adapters, even those made by Electro-Harmonix, could cause harm to the unit, the adapter or you. The FLANGER HOAX does not use batteries.

### - BACKGROUND -

The Flanger Hoax is made up of two separate phaser sections and their associated Delay Lines. The phaser sections are the Fixed Phaser and Swept Phaser. The Fixed Phaser will shift the phase of your input signal by a set amount of 240°. The Swept Phaser is more like a traditional phaser, modulated by a low frequency sine wave called the Modulator. Each phaser circuit is followed by its own analog delay line, each of which can also be independently swept by the Modulator. Each phaser section can be bypassed to access the delay lines without any phase shift. To top it all off, there is a Feedback control that allows you to send the wet output of the pedal or the output of the Swept Phaser back into the phaser circuits.

Flanger Hoax Block Diagram

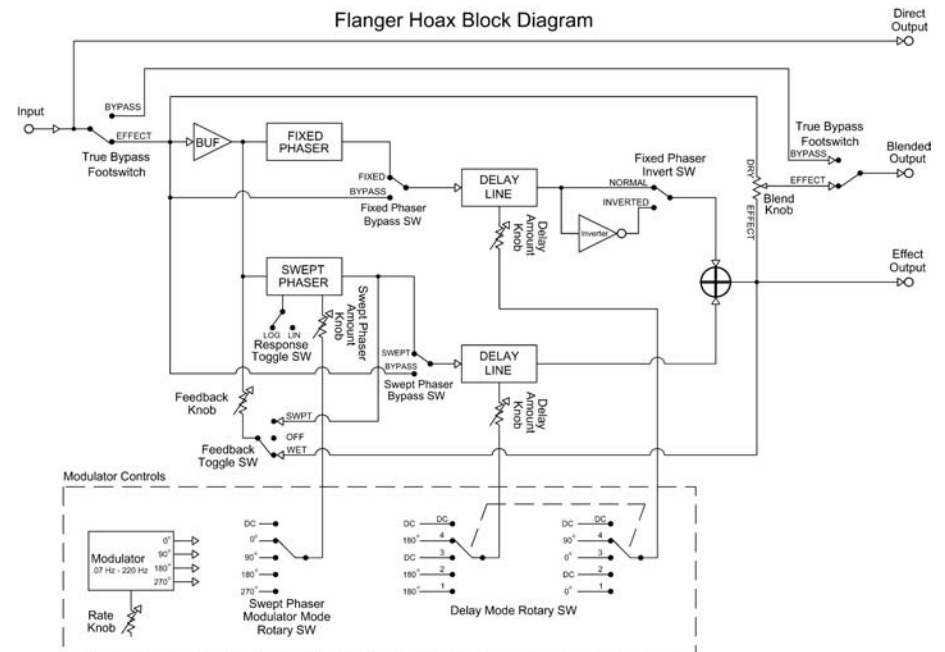

### - CONTROLS -

1. BLEND Knob: Mixes between the effect and the dry signal. The counter-clockwise position is all dry, while the clockwise position is all effect. The result of the BLEND Control goes out the BLENDED OUTPUT Jack.

#### 2. FEEDBACK CONTROLS:

FEEDBACK Knob: Sets the amount of signal that is fed back into both phase shift circuits. The counter-clockwise position gives you no feedback; the clockwise position yields maximum feedback.

WET Toggle Switch Position: In the WET position, the wet signal (which is at the EFFECT OUTPUT Jack) is fed back to the phaser circuits.

OFF Toggle Switch Position: All feedback is turned off, no matter where the FEEDBACK knob is set.

SWPT Toggle Switch Position: In the SWPT Position, the output of the Swept Phaser is fed back into the Phaser circuits.

#### 3. SWEPT PHASER CONTROL:

AMOUNT Knob: Controls the amount of modulation that sweeps the Swept Phaser. In the counter-clockwise position, there will be no modulation. In the clockwise position you will have maximum modulation. The total phase shift range of the Swept Phaser is 240° to 990°.

RESPONSE Rotary Switch: Determines how the Swept Phaser reacts to the modulation waveform. In LIN Mode, the Phaser reacts in a linear fashion, in LOG mode, it reacts in a logarithmic fashion. In the LOG mode, the Swept Phaser tends to sound more exaggerated.

MODULATOR MODE Rotary Switch: This switch steps through the different phases of the modulation waveform. When used in tandem with Delay modulation, interesting effects arise when the Swept Phaser modulation is in or out of phase with the Delay modulation. The rightmost position of this switch is DC Mode, in which the Swept Phaser becomes a fixed phaser and the amount of phase shift is controlled with the AMOUNT Knob.

#### 4. MODULATOR

RATE Knob: Sets the frequency of the sine wave Modulator. The available frequency range is from 0.07 Hz (14 Seconds) to 220 Hz.

DELAY MODE Switch: Selects between different phase shift combinations for the modulating waveform that sweeps the Fixed Phaser Delay line and the Swept Phaser Delay line:

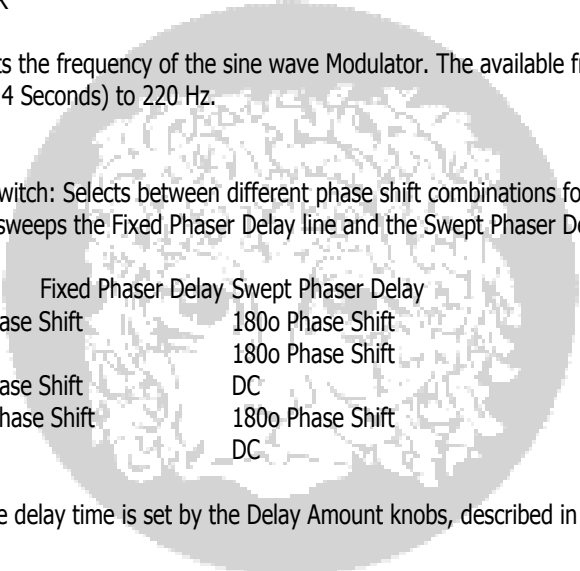

	Fixed Phaser Delay	Swept Phaser Delay
Mode 1:	0o Phase Shift	180o Phase Shift
Mode 2:	DC	180o Phase Shift
Mode 3:	0o Phase Shift	DC
Mode 4:	90o Phase Shift	180o Phase Shift
Mode 5:	DC	DC

In DC Mode, the delay time is set by the Delay Amount knobs, described in the following section.

5. FIXED and SWEPT PHASER Sections: The Flanger Hoax has two independent phase shifter circuits: a FIXED Phaser and SWEPT Phaser. The FIXED Phaser is set to a phase shift of 240o. The SWEPT Phaser varies from 240o to 990o. These two phase shift sections run parallel to each other. The output of each phase shifter goes into its own Delay line circuit. The FIXED and SWEPT Phaser blocks on the right side of the Flanger Hoax have similar controls, though the SWEPT PHASER has additional controls in the SWEPT PHASER CONTROL Block:

DELAY AMOUNT: Controls the amplitude of the sine wave that modulates the delay time or when set to DC mode, sets the delay time. The DELAY MODE Switch in the MODULATOR section chooses between waveform modulation or DC (see the chart above). The range of delay time is 1 ms to 11 ms.

FIXED/BYPASS Toggle Switch: Either bypasses the FIXED Phaser circuit or enables it. When in Bypass, the audio signal will go around the FIXED Phaser circuit and then into its Delay line. When in Fixed mode, the audio signal goes through the FIXED Phaser and then into its Delay line.

SWEPT/BYPASS Toggle Switch: Either bypasses the SWEPT Phaser circuit or enables it. When in Bypass, the audio signal will go around the SWEPT Phaser circuit and then into its Delay line. When in Fixed mode, the audio signal goes through the SWEPT Phaser and then into its Delay line.

INVERT Toggle Switch: This switch inverts the output of the FIXED Phaser block after its Delay line circuitry. By enabling the INVERT Switch, you add 180o more phase shift to the FIXED Phaser output. The SWEPT Phaser does not have an invert switch.

All Electro-Harmonix accessories are compatible and modular. Any combination of units will give you an infinite variety of sounds limited only by your imagination.