

EQUINOX

Stratos Wash RGBA

User Manual



Order code: EQLED370

WARNING

FOR YOUR OWN SAFETY, PLEASE READ THIS USER MANUAL CAREFULLY BEFORE YOUR INITIAL START-UP!

- Before your initial start-up, please make sure that there is no damage caused during transportation.
- Should there be any damage, consult your dealer and do not use the equipment.
- To maintain the equipment in good working condition and to ensure safe operation, it is necessary for the user to follow the safety instructions and warning notes written in this manual.
- Please note that damages caused by user modifications to this equipment are not subject to warranty.



IMPORTANT:

The manufacturer will not accept liability for any resulting damages caused by the non-observance of this manual or any unauthorised modification to the equipment.

- Never let the power cable come into contact with other cables. Handle the power cable and all mains voltage connections with particular caution!
- Never remove warning or informative labels from the unit.
- Do not open the equipment and do not modify the unit.
- Do not connect this equipment to a dimmer pack.
- Do not switch the equipment on and off in short intervals, as this will reduce the system's life.
- Only use the equipment indoors.
- Do not expose to flammable sources, liquids or gases.
- Always disconnect the power from the mains when equipment is not in use or before cleaning! Only handle the power-cable by the plug. Never pull out the plug by pulling the power-cable.
- Make sure that the available mains supply voltage is between 100~240V AC, 50/60Hz.
- Make sure that the power cable is never crimped or damaged. Check the equipment and the power cable periodically.
- If the equipment is dropped or damaged, disconnect the mains power supply immediately and have a qualified engineer inspect the equipment before operating again.
- If the equipment has been exposed to drastic temperature fluctuation (e.g. after transportation), do not connect power or switch it on immediately. The arising condensation might damage the equipment. Leave the equipment switched off until it has reached room temperature.
- If your product fails to function correctly, stop use immediately. Pack the unit securely (preferably in the original packing material), and return it to your Pro Light dealer for service.
- Only use fuses of same type and rating.
- Repairs, servicing and power connection must only be carried out by a qualified technician. THIS UNIT CONTAINS NO USER SERVICEABLE PARTS.
- This lighting fixture is for professional use only - it is not designed for or suitable for household use. The product must be installed by a qualified technician in accordance with local territory regulations. The safety of the installation is the responsibility of the installer. The fixture presents risks of severe injury or death due to fire hazards, electric shock and falls.
- Warning! Risk Group 2 LED product according to EN 62471. Do not view the light output with optical instruments or any device that may concentrate the beam.
- WARRANTY: One year from date of purchase.

OPERATING DETERMINATIONS

If this equipment is operated in any other way, than those described in this manual, the product may suffer damage and the warranty becomes void. Incorrect operation may lead to danger e.g: short-circuit, burns and electric shocks etc.

Do not endanger your own safety and the safety of others!

Incorrect installation or use can cause serious damage to people and/or property.

Stratos Wash RGBA

This slim LED panel is powered by 288 8mm red, green, blue and amber LEDs. Featuring an ultra-wide 120 degree beam angle the fixture is suitable for washing small stages and dancefloors with intense colour. Static colours can be selected from the on-board menu along with built-in programs, master slave, sound activation and DMX. Also included is an IR remote for ease of set up and use.

- 288 x 8mm LEDs (R: 72, G: 72, B: 72, A: 72)
- Beam angle: 120°
- 209 Lux @ 2m (full on)
- DMX channels: 2/3/4/5/8/8/13
- Auto, sound active and master/slave modes
- 0-100% dimming and variable strobe
- Bracket allows for multiple rigging or floor standing applications
- 4 push button menu with LED display
- PowerCON input/output
- 3-Pin XLR input/output
- Convection cooled
- Supplied with IR remote



120° - Lux					
FULL ON	836	209	92.9	52.3	33.4
R	220	55	24.4	13.8	8.8
G	428	107	47.6	26.8	17.1
B	260	65	28.9	16.3	10.4
A	74.4	18.6	8.27	4.65	2.98

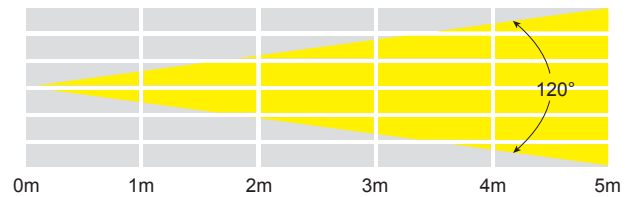

Specifications	Stratos Wash RGBA
Power consumption	40W
Power supply	100~240V, 50/60Hz
Fuse	F1A 250V
Dimensions	265 x 426 x 80mm
Weight	3.4kg
Order codes	EQLED370

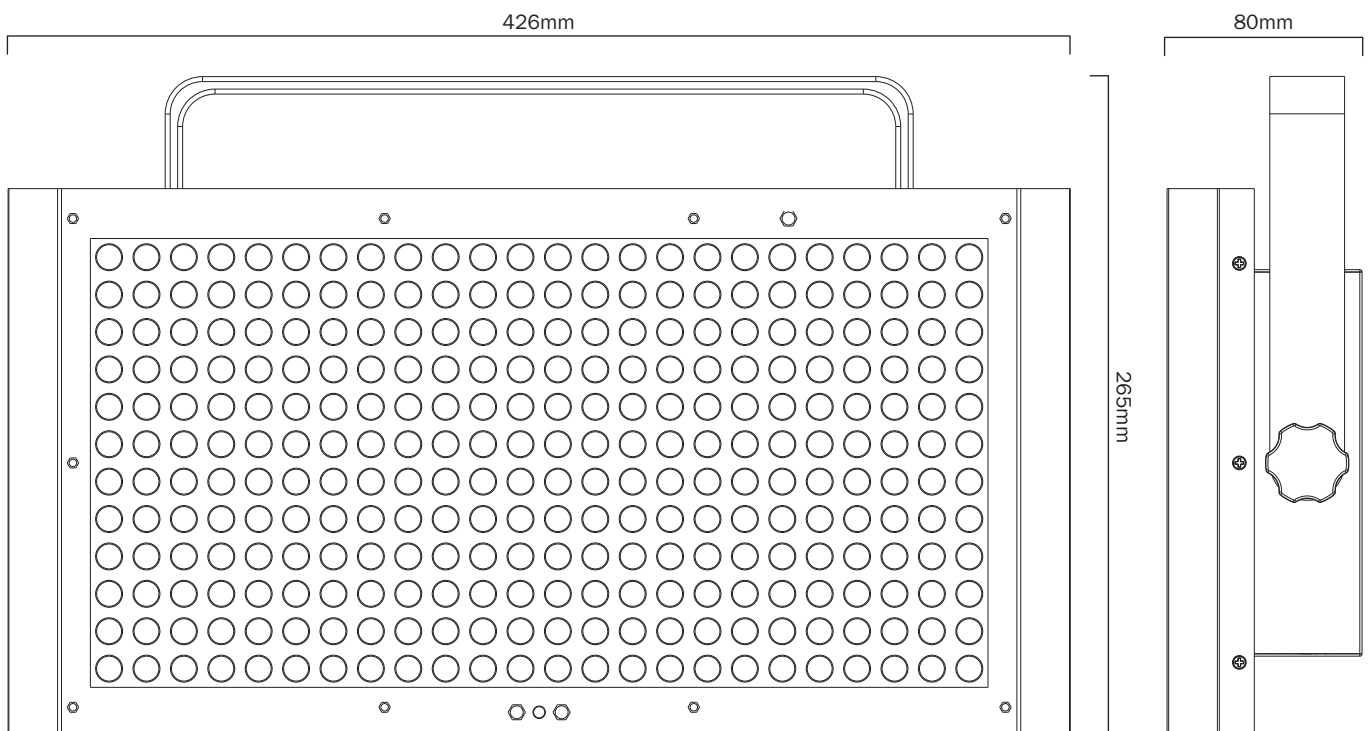

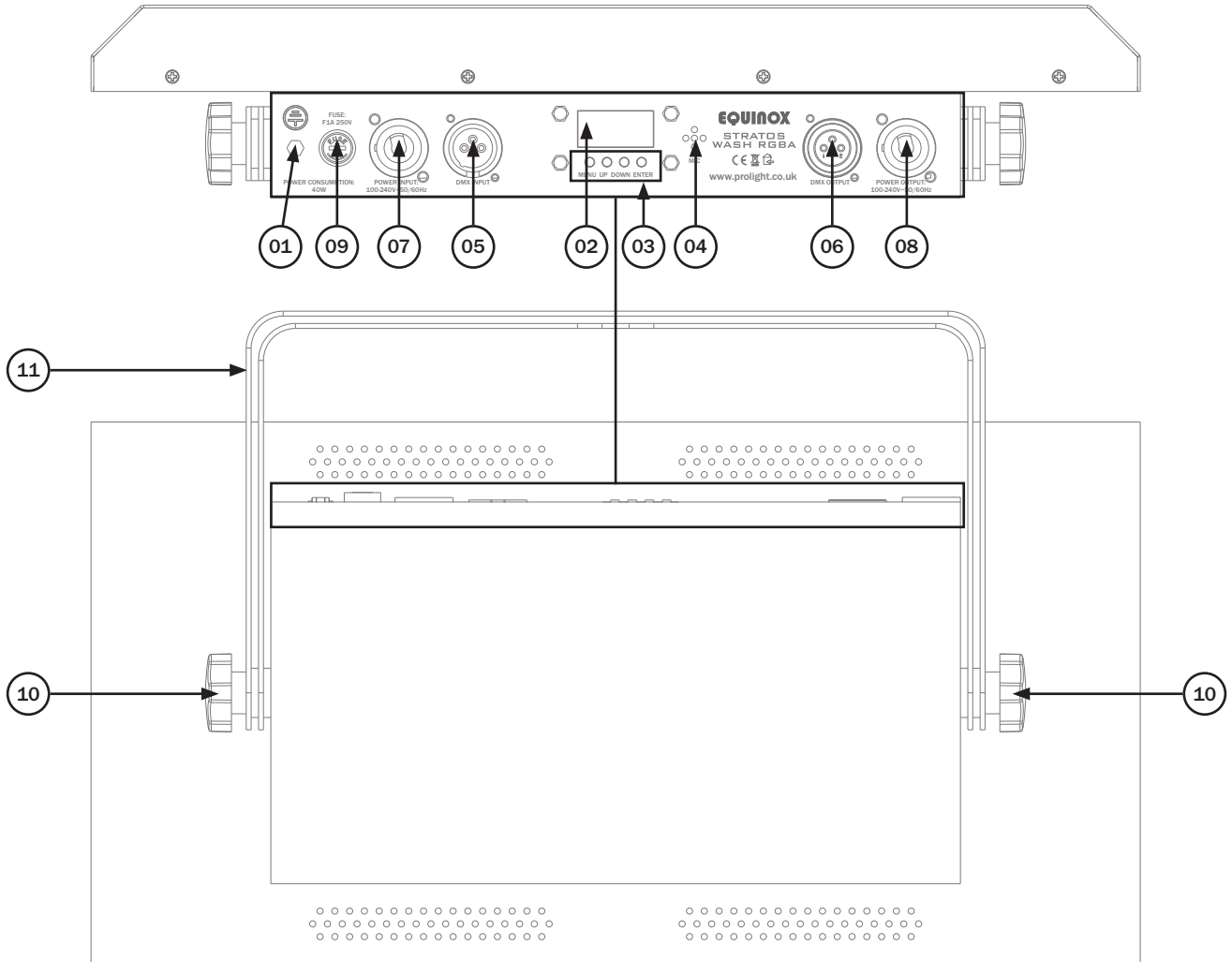

- | | | |
|-----------------------|-----------------------|--------------------|
| 01 - Earth | 05 - 3-Pin DMX input | 09 - Fuse F1A 250V |
| 02 - LED display | 06 - 3-Pin DMX output | 10 - Bracket knobs |
| 03 - Function buttons | 07 - PowerCON input | 11 - Bracket |
| 04 - Microphone | 08 - PowerCON output | |

In the box: **1 x fixture,**
1 x IR remote,
1 x power cable,
& 1 x user manual

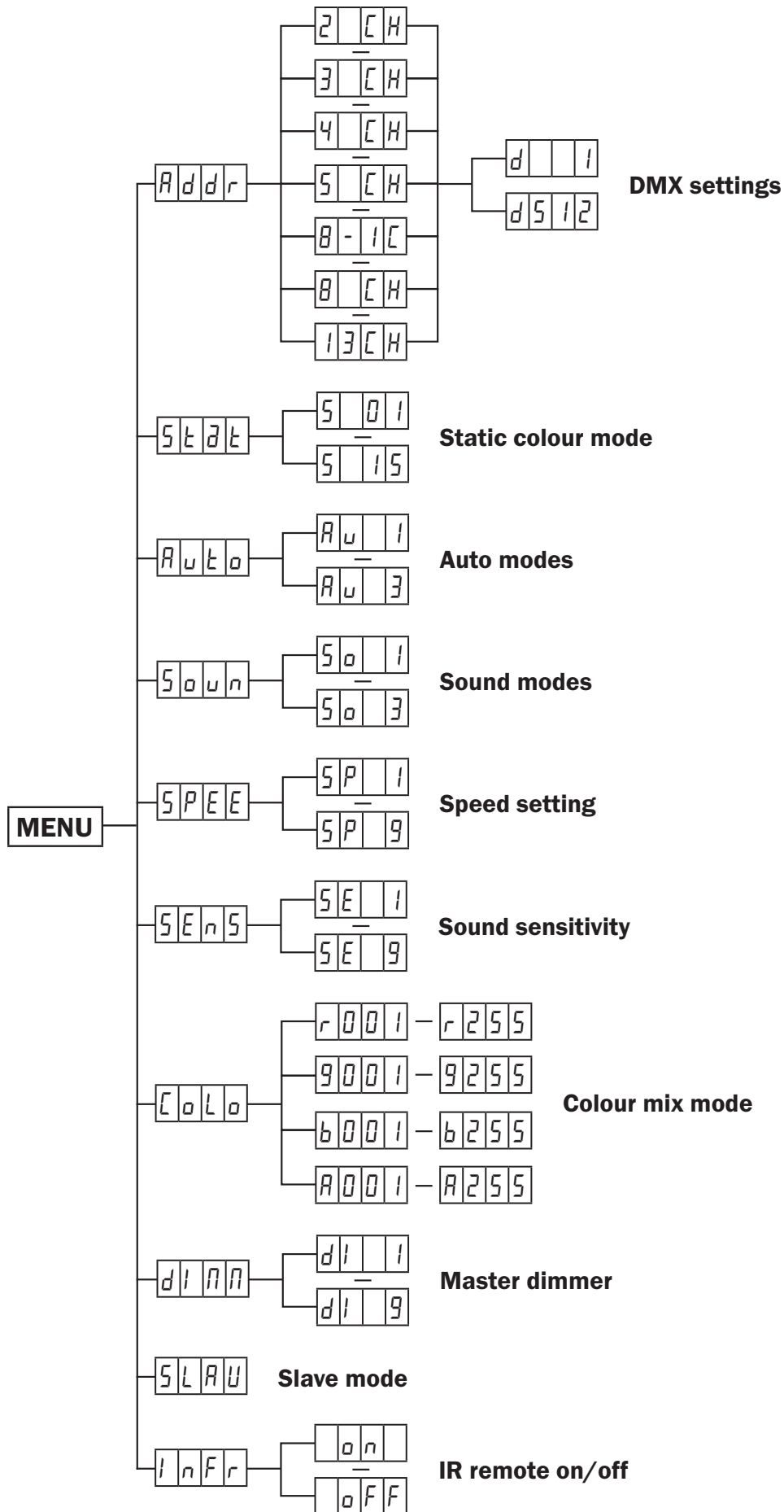

DMX mode:

Operating in a DMX control mode environment gives the user the greatest flexibility when it comes to customising or creating a show. In this mode you will be able to control each individual trait of the fixture and each fixture independently.

To access the DMX mode, press the “**MENU**” button and use the “**UP**” and “**DOWN**” buttons to show *Addr* on the LED display. Now press the “**ENTER**” button and use the “**UP**” and “**DOWN**” buttons to choose one of the 2/3/4/5/8/8 or 13 DMX channel modes.

Press the “**ENTER**” button to confirm the setting. The display will now show *Addr* on the LED display.

Press the “**ENTER**” button and use the “**UP**” and “**DOWN**” buttons to set the required DMX address.

Press the “**ENTER**” button to confirm the setting.

To exit out of any of the above options, press the “**MENU**” button.

2 channel mode:

Channel	Value	Function
CH1	000-255	Master dimmer (0-100%)
CH2	000-009	No function
	010-019	Red
	020-029	Green
	030-039	Blue
	040-049	Amber
	050-059	Light Yellow
	060-069	Light Blue
	070-079	Purple
	080-089	Dark Orange
	090-099	Lime Green
	100-109	Pink
	110-119	White (RGB)
	120-129	Yellow
	130-139	Magenta
140-149	Cyan	
150-255	White (RGBA)	

3 channel mode:

Channel	Value	Function
CH1	000-255	Red dimmer (0-100%)
CH2	000-255	Green dimmer (0-100%)
CH3	000-255	Blue dimmer (0-100%)

4 channel mode:

Channel	Value	Function
CH1	000-255	Red dimmer (0-100%)
CH2	000-255	Green dimmer (0-100%)
CH3	000-255	Blue dimmer (0-100%)
CH4	000-255	Amber dimmer (0-100%)

5 channel mode:

Channel	Value	Function	
CH1	000-255	Master dimmer (0-100%)	
CH2	000-255	Strobe (slow-fast)	
CH3	000-009	No function	Left Half of Unit
	010-019	Red	
	020-029	Green	
	030-039	Blue	
	040-049	Amber	
	050-059	Light Yellow	
	060-069	Light Blue	
	070-079	Purple	
	080-089	Dark Orange	
	090-099	Lime Green	
	100-109	Pink	
	110-119	White (RGB)	
	120-129	Yellow	
	130-139	Magenta	
140-149	Cyan		
150-255	White (RGBA)		
CH4	000-009	No function	Right Half of Unit
	010-019	Red	
	020-029	Green	
	030-039	Blue	
	040-049	Amber	
	050-059	Light Yellow	
	060-069	Light Blue	
	070-079	Purple	
	080-089	Dark Orange	
	090-099	Lime Green	
	100-109	Pink	
	110-119	White (RGB)	
	120-129	Yellow	
	130-139	Magenta	
140-149	Cyan		
150-255	White (RGBA)		
CH5	000-009	No function	
	010-049	Auto mode 1	
	050-089	Auto mode 2	
	090-129	Auto mode 3	
	130-169	Sound mode 1	
	170-209	Sound mode 2	
	210-255	Sound mode 3	

8 channel mode 1:

Channel	Value	Function	
CH1	000-255	Master dimmer (0-100%)	
CH2	000-255	Strobe (slow-fast)	
CH3	000-255	Red dimmer (0-100%)	
CH4	000-255	Green dimmer (0-100%)	
CH5	000-255	Blue dimmer (0-100%)	
CH6	000-255	Amber dimmer (0-100%)	
CH7	000-009	No function	
	010-019	Red	
	020-029	Green	
	030-039	Blue	
	040-049	Amber	
	050-059	Light Yellow	
	060-069	Light Blue	
	070-079	Purple	
	080-089	Dark Orange	
	090-099	Lime Green	
	100-109	Pink	
	110-119	White (RGB)	
	120-129	Yellow	
	130-139	Magenta	
140-149	Cyan		
150-255	White (RGBA)		
CH8	000-009	No function	
	010-049	Auto mode 1	
	050-089	Auto mode 2	
	090-129	Auto mode 3	
	130-169	Sound mode 1	
	170-209	Sound mode 2	
	210-255	Sound mode 3	

8 channel mode 2:

Channel	Value	Function	
CH1	000-255	Red dimmer (0-100%)	Left Half of Unit
CH2	000-255	Green dimmer (0-100%)	
CH3	000-255	Blue dimmer (0-100%)	
CH4	000-255	Amber dimmer (0-100%)	
CH5	000-255	Red dimmer (0-100%)	Right Half of Unit
CH6	000-255	Green dimmer (0-100%)	
CH7	000-255	Blue dimmer (0-100%)	
CH8	000-255	Amber dimmer (0-100%)	

13 channel mode:

Channel	Value	Function	
CH1	000-255	Master dimmer (0-100%)	
CH2	000-255	Strobe (slow-fast)	
CH3	000-255	Red dimmer (0-100%)	Left Half of Unit
CH4	000-255	Green dimmer (0-100%)	
CH5	000-255	Blue dimmer (0-100%)	
CH6	000-255	Amber dimmer (0-100%)	
CH7	000-255	Red dimmer (0-100%)	Right Half of Unit
CH8	000-255	Green dimmer (0-100%)	
CH9	000-255	Blue dimmer (0-100%)	
CH10	000-255	Amber dimmer (0-100%)	
CH11	000-009	No function	Left Half of Unit
	010-019	Red	
	020-029	Green	
	030-039	Blue	
	040-049	Amber	
	050-059	Light Yellow	
	060-069	Light Blue	
	070-079	Purple	
	080-089	Dark Orange	
	090-099	Lime Green	
	100-109	Pink	
	110-119	White (RGB)	
	120-129	Yellow	
130-139	Magenta		
140-149	Cyan		
150-255	White (RGBA)		

Channel	Value	Function	
CH12	000-009	No function	Right Half of Unit
	010-019	Red	
	020-029	Green	
	030-039	Blue	
	040-049	Amber	
	050-059	Light Yellow	
	060-069	Light Blue	
	070-079	Purple	
	080-089	Dark Orange	
	090-099	Lime Green	
	100-109	Pink	
	110-119	White (RGB)	
	120-129	Yellow	
	130-139	Magenta	
	140-149	Cyan	
150-255	White (RGBA)		
CH13	000-009	No function	
	010-049	Auto mode 1	
	050-089	Auto mode 2	
	090-129	Auto mode 3	
	130-169	Sound mode 1	
	170-209	Sound mode 2	
	210-255	Sound mode 3	

Static colour mode:

To access the static colour mode, press the “MENU” button and use the “UP” and “DOWN” buttons to show *S t a t* on the LED display. Now press the “ENTER” button and use the “UP” and “DOWN” buttons to choose one of the static colours between *S 0 1 ~ S 1 5*.

Press the “ENTER” button to confirm the setting.

To exit out of any of the above options, press the “MENU” button.

Colour macros:

01	Red	06	Light Blue	11	White (RGB)
02	Green	07	Purple	12	Yellow
03	Blue	08	Dark Orange	13	Magenta
04	Amber	09	Lime Green	14	Cyan
05	Light Yellow	10	Pink	15	White (RGBA)

Auto modes:

To access the auto modes, press the “MENU” button and use the “UP” and “DOWN” buttons to show *A u t o* on the LED display. Now press the “ENTER” button and use the “UP” and “DOWN” buttons to choose one of the auto modes between *A u 1 ~ A u 3*.

Press the “ENTER” button to confirm the setting.

To exit out of any of the above options, press the “MENU” button.

Sound modes:

To access the sound modes, press the “MENU” button and use the “UP” and “DOWN” buttons to show *S o u n d* on the LED display. Now press the “ENTER” button and use the “UP” and “DOWN” buttons to choose one of the sound modes between *S o 1 ~ S o 3*.

Press the “ENTER” button to confirm the setting.

To exit out of any of the above options, press the “MENU” button.

Speed setting:

To access the speed setting for auto and sound modes, press the “MENU” button and use the “UP” and “DOWN” buttons to show *S P E E* on the LED display. Now press the “ENTER” button and use the “UP” and “DOWN” buttons to select between *S P 1 ~ S P 9*.

Press the “ENTER” button to confirm the setting.

To exit out of any of the above options, press the “MENU” button.

Sound sensitivity:

To access the sound sensitivity setting, press the “MENU” button and use the “UP” and “DOWN” buttons to show *S E n S* on the LED display. Now press the “ENTER” button and use the “UP” and “DOWN” buttons to select the sound sensitivity between *S E 1 ~ S E 9*.

Press the “ENTER” button to confirm the setting.

To exit out of any of the above options, press the “MENU” button.

Colour mix mode:

To access the colour mix mode, press the “MENU” button to show **C O L O** on the LED display.

Now press the “ENTER” button and use the “UP” and “DOWN” buttons to choose **r 00 1**.

Press the “ENTER” button and use the “UP” and “DOWN” buttons to select the brightness of Red between **000 ~ 255**. Value: **000 - 255 (000 = low, 255 = high)**. Now press the “ENTER” button and repeat for **g** Green, **b** Blue and **A** Amber

Press the “ENTER” button to confirm the setting.

To exit out of any of the above options, press the “MENU” button.

Master dimmer:

To access the master dimmer setting, press the “MENU” button and use the “UP” and “DOWN” buttons to show **d i n n** on the LED display. Now press the “ENTER” button and use the “UP” and “DOWN” buttons to select the brightness between **d i 1 ~ d i 9**.

Press the “ENTER” button to confirm the setting.

To exit out of any of the above options, press the “MENU” button.

Please note: this overrides the brightness for static colour, auto, sound and colour mix modes.

Master/slave mode:

To set the master unit, press the “MENU” button and use the “UP” and “DOWN” buttons to select one of the program modes.

To set the other units in slave mode, press the “MENU” button and use the “UP” and “DOWN” buttons to show **S L A U** on the LED display. Press the “ENTER” button to confirm the setting.

The unit will now run in sequence with the master unit.

To exit out of any of the above options, press the “MENU” button.

Please ensure that all slave units are set to the same DMX channel mode as the master unit.

IR remote setting:

To access the IR remote setting, press the “MENU” button and use the “UP” and “DOWN” buttons to show **I n F r** on the LED display. Now press the “ENTER” button and use the “UP” and “DOWN” buttons to choose between **o n** or **o F F**. Press the “ENTER” button to confirm the setting.

To exit out of any of the above options, press the “MENU” button.

IR remote functions:

- 01 - Sets the unit into blackout off/on (LED on/off)
- 02 - Activates the auto modes, use the '+' and '-' buttons to select the auto mode. Pressing the 'Speed' button followed by the '+' and '-' buttons will then allow the auto mode speed to be adjusted
- 03 - Activates the sound modes, use the '+' and '-' buttons to select the sound mode. Pressing the 'Sensitivity' button followed by the '+' and '-' buttons will then allow the sound sensitivity be adjusted
- 04 - Activates the strobe, use the '+' and '-' buttons to adjust the strobe speed
- 05 - Sets the auto mode speed. Press this button followed by the '+' and '-' buttons to adjust the program speed
- 06 - Sets the sound mode sensitivity. Press this button followed by the '+' and '-' buttons to adjust the sound sensitivity
- 07 - Activates the DMX mode
Please note: the DMX address and channel must be preset in the menu
- 08 - Activates the static colour/manual modes, use the '+' and '-' buttons to select a colour from the pre-programmed static colours or use the 'R', 'G', 'B' or 'A' buttons to create a manual colour. Pressing the 'Fade/unit' button allows the chosen colour to enter the fade program
- 09 - Activates the fade mode
- 10 - Manual colour selection
A - Red B - Green C - Blue D - Amber
- 11 - Adjusts the auto mode, sound mode, speed, sound sensitivity, strobe speed and static colour/manual colour modes
- 12 - Sets the brightness of auto, sound, static colour and manual modes (1 - low brightness, 9 - high brightness)

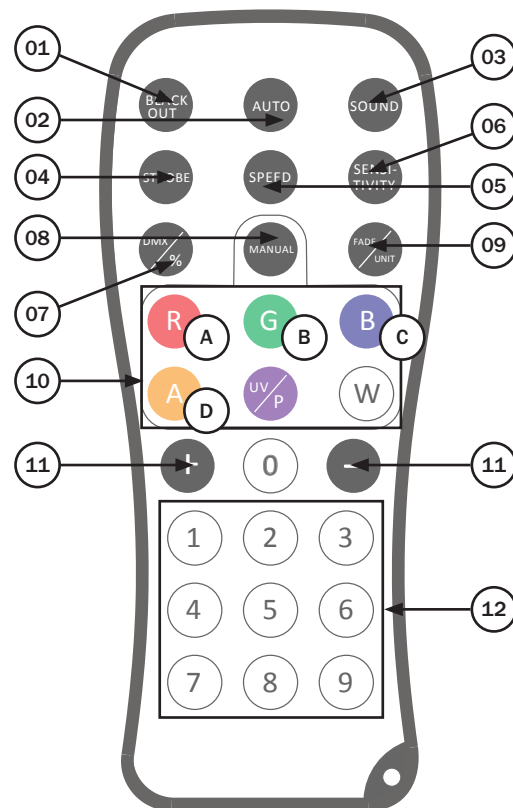

Setting the DMX address:

The DMX mode enables the use of a universal DMX controller. Each fixture requires a “start address” from 1- 512. A fixture requiring one or more channels for control begins to read the data on the channel indicated by the start address. For example, a fixture that occupies or uses 7 channels of DMX and was addressed to start on DMX channel 100, would read data from channels: 100,101,102,103,104,105 and 106. Choose a start address so that the channels used do not overlap. E.g. the next unit in the chain starts at 107.

DMX 512:

DMX (Digital Multiplex) is a universal protocol used as a form of communication between intelligent fixtures and controllers. A DMX controller sends DMX data instructions from the controller to the fixture. DMX data is sent as serial data that travels from fixture to fixture via the DATA “IN” and DATA “OUT” XLR terminals located on all DMX fixtures (most controllers only have a data “out” terminal).

DMX linking:

DMX is a language allowing all makes and models of different manufactures to be linked together and operate from a single controller, as long as all fixtures and the controller are DMX compliant. To ensure proper DMX data transmission, when using several DMX fixtures try to use the shortest cable path possible. The order in which fixtures are connected in a DMX line does not influence the DMX addressing. For example; a fixture assigned to a DMX address of 1 may be placed anywhere in a DMX line, at the beginning, at the end, or anywhere in the middle. When a fixture is assigned a DMX address of 1, the DMX controller knows to send DATA assigned to address 1 to that unit, no matter where it is located in the DMX chain.

DATA cable (DMX cable) requirements (for DMX operation):

This fixture can be controlled via DMX-512 protocol. The DMX address is set on the back of the unit. Your unit and your DMX controller require a standard 3-pin XLR connector for data input/output, see image below.



Further DMX cables can be purchased from all good sound and lighting suppliers or Pro Light Concepts dealers.

Please quote:

CABL10 – 2m

CABL11 – 5m

CABL12 – 10m

Also remember that DMX cable must be daisy chained and cannot be split.

Notice:

Be sure to follow the diagrams below when making your own cables. Do not connect the cables shield conductor to the ground lug or allow the shield conductor to come in contact with the XLRs outer casing. Grounding the shield could cause a short circuit and erratic behaviour.

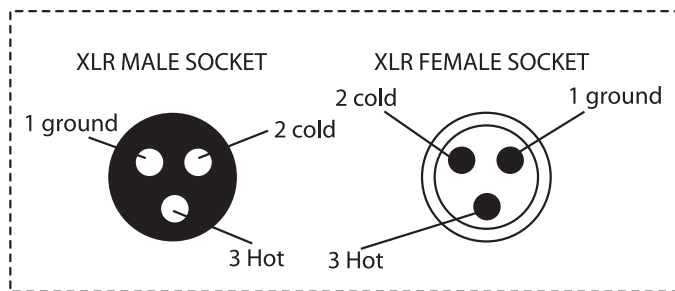
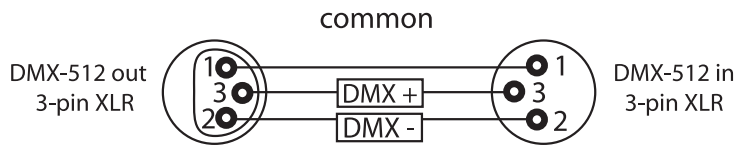

XLR Pin Configuration
Pin 1 = Ground
Pin 2 = Negative
Pin 3 = Postive

Special note:

Line termination:

When longer runs of cable are used, you may need to use a terminator on the last unit to avoid erratic behaviour.

Using a cable terminator will decrease the possibilities of erratic behaviour.

(3-pin - Order ref: CABL90, 5-pin - Order ref: CABL89)

Termination reduces signal transmission problems and interference. it is always advisable to connect a DMX terminal, (resistance 120 Ohm 1/4 W) between pin 2 (DMX-) and pin 3 (DMX+) of the last fixture.

5-pin XLR DMX connectors:

Some manufactures use 5-pin XLR connectors for data transmission in place of 3-pin. 5-pin XLR fixtures may be implemented in a 3-pin XLR DMX line. When inserting standard 5-pin XLR connectors in to a 3-pin line a cable adaptor must be used. The diagram below details the correct cable conversion.

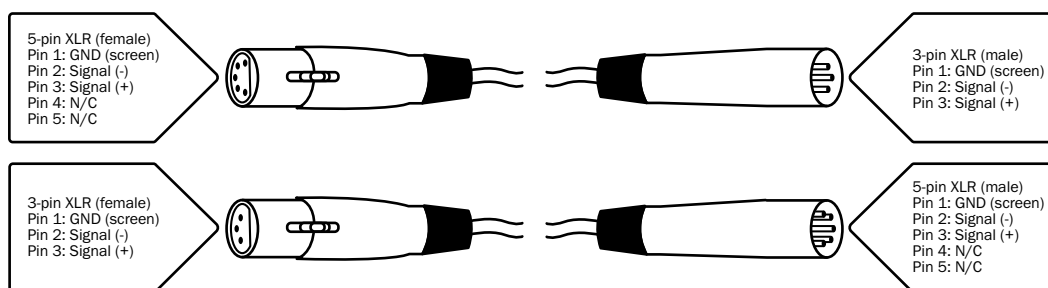



Correct Disposal of this Product (Waste Electrical & Electronic Equipment)

**(Applicable in the European Union and other European countries
with separate collection systems)**

This marking shown on the product or its literature, indicates that it should not be disposed of with other household wastes at the end of its working life. To prevent possible harm to the environment or human health from uncontrolled waste disposal, please separate this from other types of wastes and recycle it responsibly to promote the sustainable reuse of material resources.

Household users should contact either the retailer where they purchased this product, or their local government office, for details of where and how they can take this item for environmentally safe recycling.

Business users should contact their supplier and check the terms and conditions of the purchase contract. This product should not be mixed with other commercial wastes for disposal.



EQUINOX