

STRATUS

The Stratus™ is a precision crafted 24" x 48" x 2" (610mm x 1219mm x 57mm) acoustic cloud that is positioned above the listening area to eliminate ceiling to floor standing waves, early reflections and flutter echo. When installed, the Stratus delivers greater intimacy, a larger sweet spot and better stereo imaging.

The modular design comes complete with aluminum side rails that create a high-tech finished look, and allow several Stratus kits to be connected to form a large, continuous cloud. The Stratus is available in black, beige or grey fabric or in Absolute White™ paintable finish with an aluminum frame.

SPECIFICATIONS:

ORDER NUMBER	Z840-1200-XX (xx denotes color code 00=Black; 03= Beige; 08=Grey; 09=White)
FRAME MATERIAL	Formed 16-gauge aluminium
DIMENSIONS	24" (610mm) x 48" (1219mm)
PANEL DEPTH	2" (51mm)
CORE MATERIAL DENSITY	Formed, semi-rigid inorganic glass fibers, 6.0 lbs pcf (96 kg/m3)
WEIGHT	11.5 lbs (5.2 kg)
FACING	Acoustically transparent polyester or paintable glass wool tissue micromesh sealed with latex paint
BACKING	Sealed with acoustically transparent micromesh
EDGE TREATMENT	Sealed and hardened with resin
RECYCLED CONTENT	Up to 40%
LEED ELIGIBLE	Yes



Photo shows three Stratus Cloud Kits above mixing console.

ABSORPTION CHARACTERISTICS:*

Sound absorption coefficient data

PANEL DEPTH	125Hz	250Hz	500Hz	1kHz	2kHz	4kHz	NRC
2" (51mm) Depth*	0.45	0.83	1.07	1.00	1.01	1.00	1.00
2" (51mm) Offset 2" ***	0.51	.90	1.17	1.12	1.12	1.08	1.10

* Testing performed by Riverbank Acoustical Laboratories. The test method conform explicitly with the requirements of the ASTM Standard Test Method for Sound Absorption and Sound Absorption Coefficients by the Reverberation Room Method: ASTM C 423-02a and E795-05. ***Offset mounted to create an air space between the panel and ceiling.

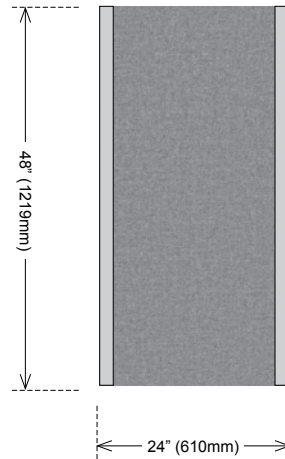
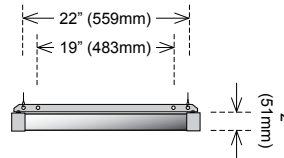
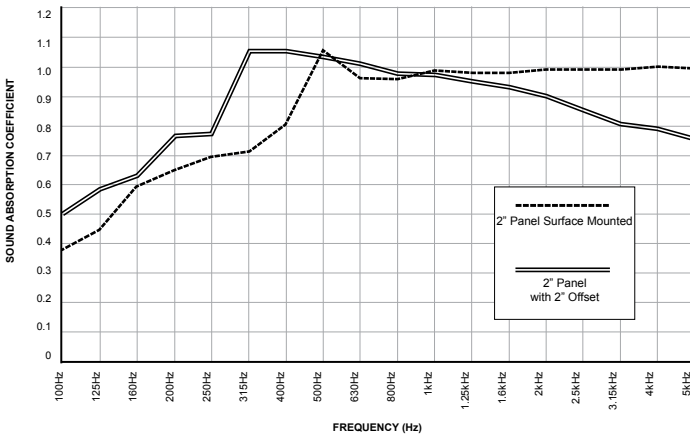

- KIT COMPONENTS:**
- 24" x 48" Broadway panel
 - Two aluminum side clamps
 - Two cross bars
 - Assembly screws
 - Bracket to link units together
 - SlipNot suspension cables
 - Drywall/Masonry Anchors
 - Eye-hooks



MOUNTING:

All suspension hardware is included. Hanging is achieved with four eyelets in the cross bar members, ceiling anchors, eye-hooks and SlipNot suspension cables. We recommend the Stratus be mounted with a four point dead-hang. Extra eyelets can be used for anti-sway or safety lines.

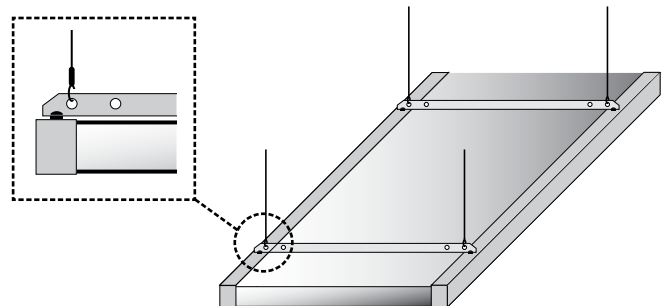

FIRE & BURN PERFORMANCE:

COUNTRY	TEST STANDARD	CLASSIFICATION
FABRIC WRAP		
Canada	CAN/ULC-S102-03	Class A/1
USA	ASTM E84-09	Class A/1
Europe	EN 13501-1	A2-s1, d0
Australia / New Zealand	AS/NZS 1530.3	(I)0, (S)0, (H)0, (Sm)5
PAINTABLE		
Canada	CAN/ULC-S102-10	Class A/1
USA	ASTM E84-11b	Class A/1
Europe	EN 13501-1	B-s2, d0
Australia / New Zealand	AS/NZS 1530.3	(I)0, (S)0, (H)0, (Sm)3