

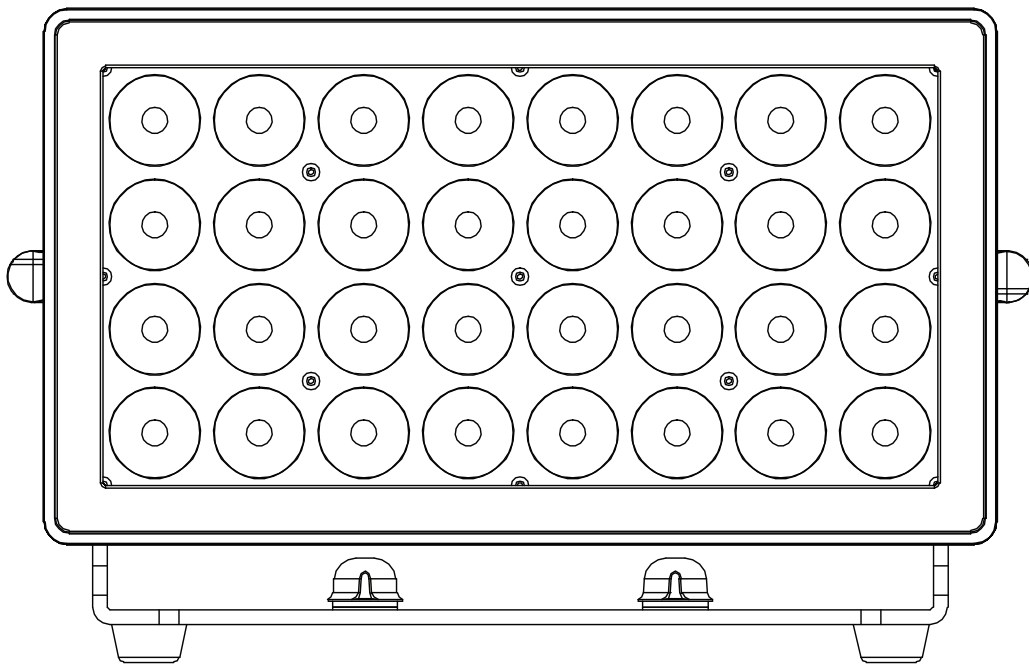

# 32 HEX PANEL IP 32 HEX PANEL IP PEARL



## *User Instructions*

©2019 ADJ Products, LLC all rights reserved. Information, specifications, diagrams, images, and instructions herein are subject to change without notice. ADJ Products, LLC logo and identifying product names and numbers herein are trademarks of ADJ Products, LLC. Copyright protection claimed includes all forms and matters of copyrightable materials and information now allowed by statutory or judicial law or hereinafter granted. Product names used in this document may be trademarks or registered trademarks of their respective companies and are hereby acknowledged. All non-ADJ Products, LLC brands and product names are trademarks or registered trademarks of their respective companies.

**ADJ Products, LLC** and all affiliated companies hereby disclaim any and all liabilities for property, equipment, building, and electrical damages, injuries to any persons, and direct or indirect economic loss associated with the use or reliance of any information contained within this document, and/or as a result of the improper, unsafe, insufficient and negligent assembly, installation, rigging, and operation of this product.

### FCC STATEMENT

This device complies with Part 15 of the FCC Rules. Operation is subject to the following two conditions: (1) this device may not cause harmful interference, and (2) this device must accept any interference received, including interference that may cause undesired operation.

### FCC RADIO FREQUENCY INTERFERENCE WARNINGS & INSTRUCTIONS

This product has been tested and found to comply with the limits as per Part 15 of the FCC Rules. These limits are designed to provide reasonable protection against harmful interference in a residential installation. This device uses and can radiate radio frequency energy and, if not installed and used in accordance with the included instructions, may cause harmful interference to radio communications. However, there is no guarantee that interference will not occur in a particular installation. If this device does cause harmful interference to radio or television reception, which can be determined by turning the device off and on, the user is encouraged to try to correct the interference by one or more of the following methods:

- Reorient or relocate the device.
- Increase the separation between the device and the receiver.
- Connect the device to an electrical outlet on a circuit different from which the radio receiver is connected.
- Consult the dealer or an experienced radio/TV technician for help.

## DOCUMENT VERSION

Please check [www.adj.com](http://www.adj.com) for the latest revision/update of this guide.

Date	Document Version	Software Version $\geq$	DMX Channel Mode	Notes
12/17/18	1	1.08	6/10/11/ 16/48/96	Initial Release
03/14/19	1.2	1.09	6/10/11/16/ 48/57/96	57 Channel Mode Added

### Europe Energy Saving Notice

Energy Saving Matters (EuP 2009/125/EC)

Saving electric energy is a key to help protecting the environment. Please turn off all electrical products when they are not in use. To avoid power consumption in idle mode, disconnect all electrical equipment from power when not in use. Thank you!

Introduction	3
Features   Warranty Registration   Installation	4
Safety Precautions	5
IP Notice	7
Installation	8
Overview	9
DMX Set Up	10
DMX Addressing	11
DMX Modes	12
Color Macro Chart	17
System Menu	19
Operating Instructions	21
Master-Slave Set Up	24
Pixel Zones	25
Dimmer Curve Chart	26
Dimensional Drawings	27
Barn Door Installation	28
Barn Door Dimensional Drawings	29
Power Linking   Trouble Shooting   Cleaning	30
Limited Warranty (USA Only)	31
Specifications	32

**Unpacking:** Thank you for purchasing the 32 Hex Panel IP/32 Hex Panel IP Pearl by ADJ Products, LLC. Every unit has been thoroughly tested and has been shipped in perfect operating condition. Carefully check the shipping carton for damage that may have occurred during shipping. If the carton appears to be damaged, carefully inspect your fixture for any damage and be sure all accessories necessary to operate the unit has arrived intact. In the case damage has been found or parts are missing, please contact our toll free customer support number for further instructions. Do not return this unit to your dealer without first contacting customer support.

**Introduction:** The 32 Hex Panel IP/32 Hex Panel IP Pearl is a DMX intelligent, IP rated LED wash fixture. This fixture can be used in a stand alone mode or connected in a Master/Slave configuration. This fixture has five operating modes: RGBWA + UV dimmer mode, Static Color mode, Auto Run mode, Color Macro mode, and DMX control. The 32 Hex Panel IP/32 Hex Panel IP Pearl has 7 DMX channel modes; 6, 10, 11, 16, 48, 57, & 96.

***This product is intended to be used by professionally trained personnel only and is not suitable for private use.***

**Customer Support:** Contact ADJ Service for any product related service and support needs. Also visit [forums.adj.com](http://forums.adj.com) with questions, comments or suggestions.

**Parts:** To purchase parts online visit <http://parts.americandj.com>

**ADJ SERVICE USA - Monday - Friday 8:00am to 4:30pm PST**

**Voice: 323-582-2650 | Fax: 323-832-2941 | support@adj.com**

**ADJ SERVICE EUROPE - Monday - Friday 08:30 to 17:00 CET**

**Voice: +31 45 546 85 60 | Fax: +31 45 546 85 96 | support@adj.eu**

**Caution!** There are no user serviceable parts inside this unit. Do not attempt any repairs yourself, doing so will void your manufactures warranty. In the unlikely event your unit may require service please contact ADJ Products, LLC.

***PLEASE recycle the shipping carton when ever possible.***

## 32 Hex Panel IP/32 Hex Panel IP Pearl

## Features

- Multi-Colors
- Five Operating Modes
- Electronic Dimming 0-100%
- DMX-512 protocol
- 5-Pin DMX Connections
- 7 DMX Channel Modes: 6/10/11/16/48/57/96
- Multiple Unit Power Linking (See page 30)

Included:

- 1 x Seetronic IP65 Cable
- 2 x Safety Cables
- 1 x Magnetic Removable Frost Filter

## 32 Hex Panel IP/32 Hex Panel IP Pearl

## Warranty Registration

The 32 Hex Panel IP/32 Hex Panel IP Pearl carries a 2 year limited warranty. Please fill out the enclosed warranty card to validate your purchase. All returned service items whether under warranty or not, must be freight pre-paid and accompany a return authorization (R.A.) number. The R.A. number must be clearly written on the outside of the return package. A brief description of the problem as well as the R.A. number must also be written down on a piece of paper included in the shipping carton. If the unit is under warranty, you must provide a copy of your proof of purchase invoice. You may obtain a R.A. number by contacting our customer support team on our customer support number. All packages returned to the service department not displaying a R.A. number on the outside of the package will be returned to the shipper.

## 32 Hex Panel IP/32 Hex Panel IP Pearl

## Installation

The unit should be mounted using a mounting clamp (not provided), affixing it to the mounting bracket that is provided with the unit. Always ensure that the unit is firmly fixed to avoid vibration and slipping while operating. Always ensure that the structure to which you are attaching the unit is secure and is able to support a weight of 10 times the unit's weight. **ALWAYS** use safety cables that can hold 12 times the weight of the unit when installing the fixture. **Note: 2 safety cables are provided, one safety cable is for the unit itself, the second safety cable is for the LED array cover.** This equipment must be installed by a professional, and it must be installed in a place where it is out of the reach of people's grasp.

**Ensure ALL connections and end caps are properly sealed with a non-conductive dielectric grease (available at most electrical suppliers) to prevent water ingress/condensation and/or corrosion.**

- Do not attempt to operate this unit if the power cord has been frayed or broken. Do not attempt to remove or break off the ground prong from the electrical cord. This prong is used to reduce the risk of electrical shock and fire in case of an internal short.
- Disconnect from main power before making any type of connection.
- Do not remove the cover under any conditions. There are no user serviceable parts inside.
- Never operate this unit when it's cover is removed.
- Never plug this unit in to a dimmer pack
- Always be sure to mount this unit in an area that will allow proper ventilation. Allow about 6" (15cm) between this device and a wall.
- Do not attempt to operate this unit, if it becomes damaged.
- During long periods of non-use, disconnect the unit's main power.
- Always mount this unit in safe and stable matter.
- Power-supply cords should be routed so that they are not likely to be walked on or pinched by items placed upon or against them, paying particular attention to the point they exit from the unit.
- Cleaning -The fixture should be cleaned only as recommended by the manufacturer. See page 30 for cleaning details.
- Heat -The appliance should be situated away from heat sources such as radiators, heat registers, stoves, or other appliances (including amplifiers) that produce heat.
- The fixture should be serviced by qualified service personnel when:
  - A. The power-supply cord or the plug has been damaged.
  - B. Objects have fallen, or liquid has been spilled into the fixture.
  - C. The fixture does not appear to operate normally or exhibits a marked change in performance.
  - D. The fixture has fallen and/or subjected to extreme handling.

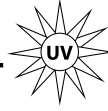
**! CAUTION****HIGH  
INTENSITY  
ULTRAVIOLET  
LIGHT****AVOID DIRECT EYE & SKIN EXPOSURE.  
WEAR PROPER EYE & SKIN PROTECTION.  
SEE MANUAL FOR SAFETY INSTRUCTIONS.****RISK GROUP 3 - RISK OF EXPOSURE TO ULTRAVIOLET (UV) RADIATION!****FIXTURE EMITS HIGH INTENSITY ULTRAVIOLET (UV) LIGHT FROM THE UV LED.****WEAR PROPER EYE AND SKIN PROTECTION.****AVOID PROLONGED PERIODS OF EXPOSURE TO THE UV LED.****AVOID WEARING WHITE COLOR CLOTHING AND/OR USING (UV) PAINTS ON SKIN.****AVOID DIRECT EYE AND/OR SKIN EXPOSURE AT DISTANCES SHORTER THAN 11 feet (3.3m).****DO NOT OPERATE FIXTURE WITH DAMAGED OR MISSING EXTERNAL COVER.****DO NOT LOOK DIRECTLY INTO THE (UV) LIGHT AND/OR VIEW (UV) LIGHT DIRECTLY WITH OPTICAL INSTRUMENTS THAT MAY CONCENTRATE THE LIGHT/RADIATION OUTPUT.****INDIVIDUALS SUFFERING FROM A RANGE OF EYE CONDITIONS, SUNLIGHT EXPOSURE DISORDERS, OR INDIVIDUALS USING PHOTSENSITIVE MEDICATION, MAY RECEIVE DISCOMFORT IF EXPOSED TO THE ULTRAVIOLET (UV) LIGHT EMITTED FROM THIS FIXTURE.**

**IP65 RATED**

An IP rated lighting fixture is one, which is commonly installed in outdoor environments and has been designed with an enclosure that effectively protects the ingress (entry) of external foreign objects such as dust and water. The International Protection (IP) rating system is commonly expressed as "IP" (Ingress Protection) followed by two numbers (i.e. IP65) where the numbers define the degree of protection. The first digit (Foreign Bodies Protection) indicates the extent of protection against particles entering the fixture and the second digit (Water Protection) indicates the extent of protection against water entering the fixture. An IP65 rated lighting fixture is one, which has been designed and tested to protect against the ingress of dust (6) and high-pressure water jets from any direction (5).

**MARINE/COASTAL ENVIRONMENT INSTALLATIONS**

NOT suitable for marine and/or coastal environment installations. Installing this fixture in a marine and/or coastal environment may cause corrosion and/or excessive wear to the interior and/or exterior components of the fixture. Damages and/or performance issues resulting from installation in a marine and/or coastal environment will void the manufactures warranty and will NOT be subJect to any warranty claims and/or repairs.



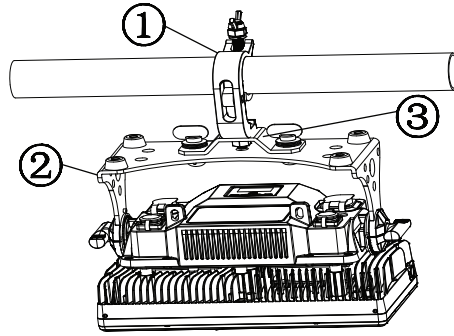

- ① OPTIONAL CLAMP (Not Included)
- ② ADJUSTABLE MOUNTING BRACKET
- ③ OPTIONAL OMEGA BRACKET (Not Included)

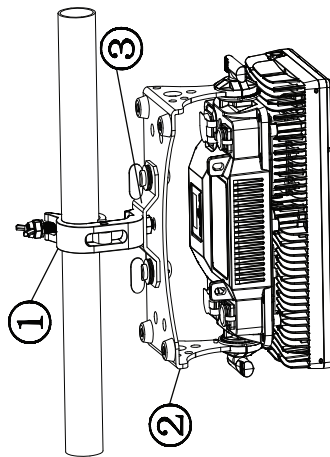

The 32 Hex Panel IP is fully operational in three different mounting positions; hanging upside-down, mounted sideways on trussing, or set on a flat level surface. Be sure this fixture is kept at least 12m (40ft) away from any flammable materials (decoration etc.). **ALWAYS** use and install the supplied safety cable as a safety measure to prevent accidental damage and/or injury in the event the clamp fails.

Screw one clamp via a M12 screw and nut into the Omega holder. Insert the quick-lock fasteners of the Omega holder into the respective holes of the adjustable mounting bracket. Tighten the quick-lock fasteners fully clockwise. Pull the safety-cable through the openings located on the rear of the unit and over the trussing system or a safe fixation spot. Insert the end in the carabine and tighten the safety screw.

Always ensure that the unit is firmly fixed to avoid vibration and slipping while operating. Always ensure that the structure to which you are attaching the unit is secure and is able to support a weight of 10 times the unit's weight. **ALWAYS** use safety cables that can hold 12 times the weight of the unit when installing the fixture.

This equipment must be installed by a professional, and it must be installed in a place where it is out of the reach of people's grasp.

**Ensure ALL connections and end caps are properly sealed with a non-conductive dielectric grease (available at most electrical suppliers) to prevent water ingress/condensation and/or corrosion.**

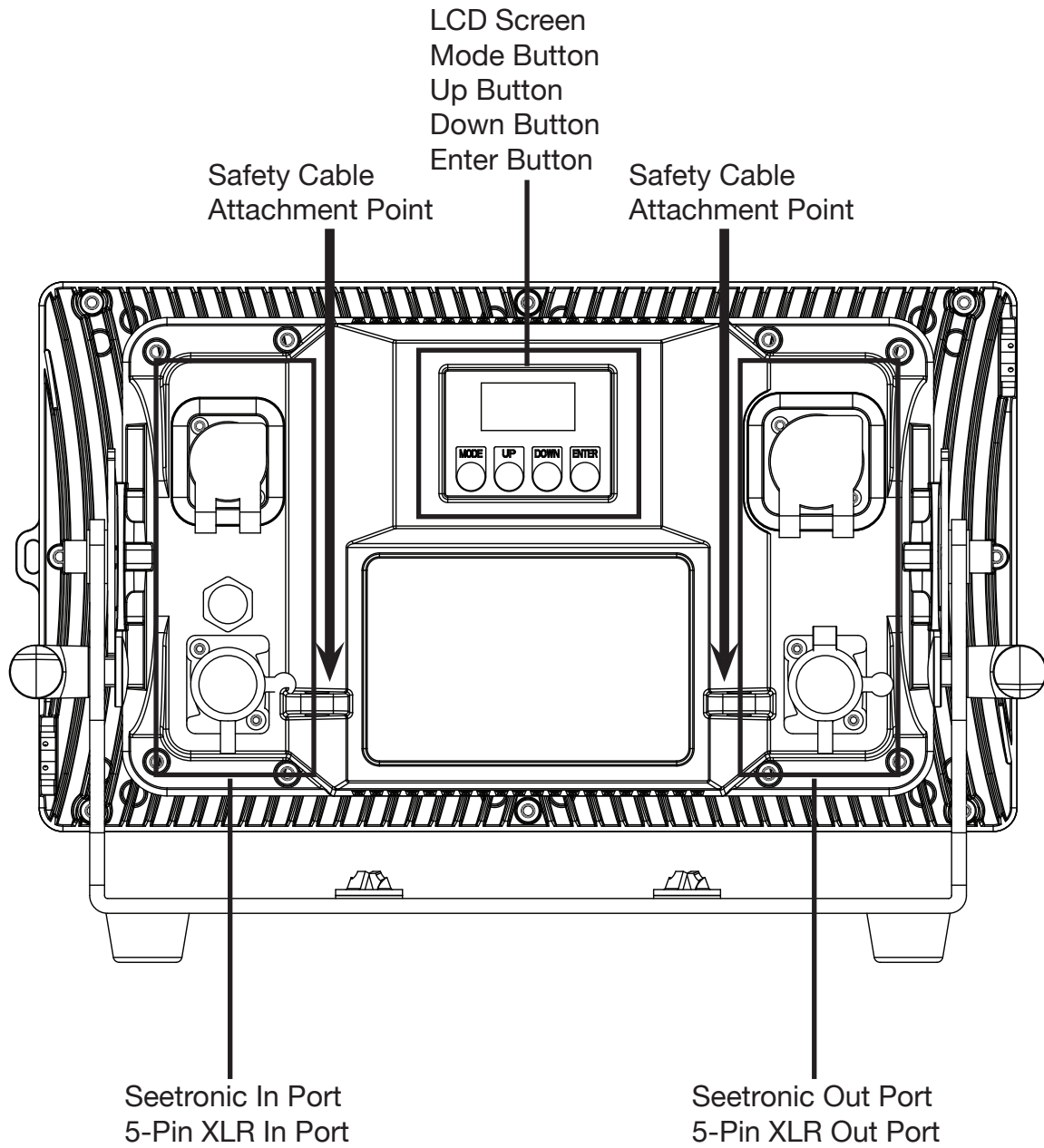

**DMX-512:** DMX is short for Digital Multiplex. This is a universal protocol used as a form of communication between intelligent fixtures and controllers. A DMX controller sends DMX data instructions from the controller to the fixture. DMX data is sent as serial data that travels from fixture to fixture via the DATA “IN” and DATA “OUT” XLR terminals located on all DMX fixtures (most controllers only have a DATA “OUT” terminal).

**DMX Linking:** DMX is a language allowing all makes and models of different manufactures to be linked together and operate from a single controller, as long as all fixtures and the controller are DMX compliant. To ensure proper DMX data transmission, when using several DMX fixtures try to use the shortest cable path possible. The order in which fixtures are connected in a DMX line does not influence the DMX addressing. For example; a fixture assigned a DMX address of 1 may be placed anywhere in a DMX line, at the beginning, at the end, or anywhere in the middle. When a fixture is assigned a DMX address of 1, the DMX controller knows to send DATA assigned to address 1 to that unit, no matter where it is located in the DMX chain.

**Data Cable (DMX Cable) Requirements (For DMX Operation):** The 32 Hex Panel IP/32 Hex Panel IP Pearl can be controlled via DMX-512 protocol. The 32 Hex Panel IP/32 Hex Panel IP Pearl has 7 DMX channel modes. The DMX address is set on the back panel of the 32 Hex Panel IP/32 Hex Panel IP Pearl. Your unit and your DMX controller require a standard 5-pin XLR connector for data input and data output. We recommend Accu-Cable DMX cables. If you are making your own cables, be sure to use standard 110-120 Ohm shielded cable (This cable may be purchased at almost all pro lighting stores). Your cables should be made with a male and female XLR connector on either end of the cable. Also remember that DMX cable must be daisy chained and cannot be split.

**Special Note: Line Termination.** When longer runs of cable are used, you may need to use a terminator on the last unit to avoid erratic behavior. A terminator is a 110-120 ohm 1/4 watt resistor which is connected between pins 2 and 3 of a male XLR connector (DATA + and DATA -). This unit is inserted in the female XLR connector of the last unit in your daisy chain to terminate the line. Using a cable terminator (ADJ part number Z-DMX/T) will decrease the possibilities of erratic behavior.

All fixtures should be given a DMX starting address when using a DMX controller, so the correct fixture responds to the correct control signal. This digital starting address is the channel number from which the fixture starts to “listen” to the digital control signal sent out from the DMX controller. The assignment of this starting DMX address is achieved by setting the correct DMX address on the digital control display on the fixture.

You can set the same starting address for all fixtures or a group of fixtures, or set different addresses for each individual fixture. Setting all fixtures to the same DMX address will cause all fixtures to react in the same way, in other words, changing the settings of one channel will affect all the fixtures simultaneously.

If you set each fixture to a different DMX address, each unit will start to “listen” to the channel number you have set, based on the quantity of DMX channels of each fixture. That means changing the settings of one channel will only affect the selected fixture.

In the case of the 32 Hex Panel IP/32 Hex Panel IP Pearl, when in 6 channel mode you should set the starting DMX address of the first unit to 1, the second unit to 7 (6 + 1), the third unit to 13 (7 + 6), and so on. (See chart below for more details.)

Channel Mode	Unit 1 Address	Unit 2 Address	Unit 3 Address	Unit 4 Address
6 channels	1	7	13	19
10 channels	1	11	21	31
11 channels	1	12	22	32
16 channels	1	17	33	49
48 channels	1	49	97	145
57 channels	1	58	115	172
96 channels	1	97	193	289

6 CH	10 CH	11 CH	16 CH	48 CH	57 CH	96 CH	VALUES	FUNCTIONS
1	1	1	1				000-255	<b>RED (ALL LEDS)</b> 0-100%
2	2	2	2				000-255	<b>GREEN (ALL LEDS)</b> 0-100%
3	3	3	3				000-255	<b>BLUE (ALL LEDS)</b> 0-100%
4	4	4	4				000-255	<b>WHITE (ALL LEDS)</b> 0-100%
5	5	5	5				000-255	<b>AMBER (ALL LEDS)</b> 0-100%
6	6	6	6				000-255	<b>UV (ALL LEDS)</b> 0-100%
				1	1	1	000-255	<b>RED (ZONE #1)</b> 0-100%
						2		<b>RED FINE (ZONE #1)</b>
				2	2	3	000-255	<b>GREEN (ZONE #1)</b> 0-100%
						4		<b>GREEN FINE (ZONE #1)</b>
				3	3	5	000-255	<b>BLUE (ZONE #1)</b> 0-100%
						6		<b>BLUE FINE (ZONE #1)</b>
				4	4	7	000-255	<b>WHITE (ZONE #1)</b> 0-100%
						8		<b>WHITE FINE (ZONE #1)</b>
				5	5	9	000-255	<b>AMBER (ZONE #1)</b> 0-100%
						10		<b>AMBER FINE (ZONE #1)</b>
				6	6	11	000-255	<b>UV (ZONE #1)</b> 0-100%
						12		<b>UV FINE (ZONE #1)</b>
				7	7	13	000-255	<b>RED (ZONE #2)</b> 0-100%
						14		<b>RED FINE (ZONE #2)</b>
				8	8	15	000-255	<b>GREEN (ZONE #2)</b> 0-100%
						16		<b>GREEN FINE (ZONE #2)</b>
				9	9	17	000-255	<b>BLUE (ZONE #2)</b> 0-100%
						18		<b>BLUE FINE (ZONE #2)</b>
				10	10	19	000-255	<b>WHITE (ZONE #2)</b> 0-100%
						20		<b>WHITE FINE (ZONE #2)</b>

6 CH	10 CH	11 CH	16 CH	48 CH	57 CH	96 CH	VALUES	FUNCTIONS
				11	11	21	000-255	<b>AMBER (ZONE #2)</b> 0-100%
						22		<b>AMBER FINE (ZONE #2)</b>
				12	12	23	000-255	<b>UV (ZONE #2)</b> 0-100%
						24		<b>UV FINE (ZONE #2)</b>
				13	13	25	000-255	<b>RED (ZONE #3)</b> 0-100%
						26		<b>RED FINE (ZONE #3)</b>
				14	14	27	000-255	<b>GREEN (ZONE #3)</b> 0-100%
						28		<b>GREEN FINE (ZONE #3)</b>
				15	15	29	000-255	<b>BLUE (ZONE #3)</b> 0-100%
						30		<b>BLUE FINE (ZONE #3)</b>
				16	16	31	000-255	<b>WHITE (ZONE #3)</b> 0-100%
						32		<b>WHITE FINE (ZONE #3)</b>
				17	17	33	000-255	<b>AMBER (ZONE #3)</b> 0-100%
						34		<b>AMBER FINE (ZONE #3)</b>
				18	18	35	000-255	<b>UV (ZONE #3)</b> 0-100%
						36		<b>UV FINE (ZONE #3)</b>
				19	19	37	000-255	<b>RED (ZONE #4)</b> 0-100%
						38		<b>RED FINE (ZONE #4)</b>
				20	20	39	000-255	<b>GREEN (ZONE #4)</b> 0-100%
						40		<b>GREEN FINE (ZONE #4)</b>
				21	21	41	000-255	<b>BLUE (ZONE #4)</b> 0-100%
						42		<b>BLUE FINE (ZONE #4)</b>
				22	22	43	000-255	<b>WHITE (ZONE #4)</b> 0-100%
						44		<b>WHITE FINE (ZONE #4)</b>
				23	23	45	000-255	<b>AMBER (ZONE #4)</b> 0-100%
						46		<b>AMBER FINE (ZONE #4)</b>
				24	24	47	000-255	<b>UV (ZONE #4)</b> 0-100%
						48		<b>UV FINE (ZONE #4)</b>

6 CH	10 CH	11 CH	16 CH	48 CH	57 CH	96 CH	VALUES	FUNCTIONS
				25	25	49	000-255	<b>RED (ZONE #5)</b> 0-100%
						50		<b>RED FINE (ZONE #5)</b>
				26	26	51	000-255	<b>GREEN (ZONE #5)</b> 0-100%
						52		<b>GREEN FINE (ZONE #5)</b>
				27	27	53	000-255	<b>BLUE (ZONE #5)</b> 0-100%
						54		<b>BLUE FINE (ZONE #5)</b>
				28	28	55	000-255	<b>WHITE (ZONE #5)</b> 0-100%
						56		<b>WHITE FINE (ZONE #5)</b>
				29	29	57	000-255	<b>AMBER (ZONE #5)</b> 0-100%
						58		<b>AMBER FINE (ZONE #5)</b>
				30	30	59	000-255	<b>UV (ZONE #5)</b> 0-100%
						60		<b>UV FINE (ZONE #5)</b>
				31	31	61	000-255	<b>RED (ZONE #6)</b> 0-100%
						62		<b>RED FINE (ZONE #6)</b>
				32	32	63	000-255	<b>GREEN (ZONE #6)</b> 0-100%
						64		<b>GREEN FINE (ZONE #6)</b>
				33	33	65	000-255	<b>BLUE (ZONE #6)</b> 0-100%
						66		<b>BLUE FINE (ZONE #6)</b>
				34	34	67	000-255	<b>WHITE (ZONE #6)</b> 0-100%
						68		<b>WHITE FINE (ZONE #6)</b>
				35	35	69	000-255	<b>AMBER (ZONE #6)</b> 0-100%
						70		<b>AMBER FINE (ZONE #6)</b>
				36	36	71	000-255	<b>UV (ZONE #6)</b> 0-100%
						72		<b>UV FINE (ZONE #6)</b>
				37	37	73	000-255	<b>RED (ZONE #7)</b> 0-100%
						74		<b>RED FINE (ZONE #7)</b>
				38	38	75	000-255	<b>GREEN (ZONE #7)</b> 0-100%
						76		<b>GREEN FINE (ZONE #7)</b>

6 CH	10 CH	11 CH	16 CH	48 CH	57 CH	96 CH	VALUES	FUNCTIONS
				39	39	77	000-255	<b>BLUE (ZONE #7)</b> 0-100%
						78		<b>BLUE FINE (ZONE #7)</b>
				40	40	79	000-255	<b>WHITE (ZONE #7)</b> 0-100%
						80		<b>WHITE FINE (ZONE #7)</b>
				41	41	81	000-255	<b>AMBER (ZONE #7)</b> 0-100%
						82		<b>AMBER FINE (ZONE #7)</b>
				42	42	83	000-255	<b>UV (ZONE #7)</b> 0-100%
						84		<b>UV FINE (ZONE #7)</b>
				43	43	85	000-255	<b>RED (ZONE #8)</b> 0-100%
						86		<b>RED FINE (ZONE #8)</b>
				44	44	87	000-255	<b>GREEN (ZONE #8)</b> 0-100%
						88		<b>GREEN FINE (ZONE #8)</b>
				45	45	89	000-255	<b>BLUE (ZONE #8)</b> 0-100%
						90		<b>BLUE FINE (ZONE #8)</b>
				46	46	91	000-255	<b>WHITE (ZONE #8)</b> 0-100%
						92		<b>WHITE FINE (ZONE #8)</b>
				47	47	93	000-255	<b>AMBER (ZONE #8)</b> 0-100%
						94		<b>AMBER FINE (ZONE #8)</b>
				48	48	95	000-255	<b>AMBER (ZONE #8)</b> 0-100%
						96		<b>UV FINE (ZONE #8)</b>
		7	7		49		000-031 032-063 064-095 096-127 128-159 160-191 192-223 224-255	<b>STROBE</b> LED OFF LED ON STROBING SLOW - FAST LED ON PULSE STROBING SLOW - FAST LED ON RANDOM STROBING SLOW - FAST LED ON
	7	8	8		50		000-255	<b>MASTER DIMMER 8BIT</b> 0-100%
	8	9	9		51		000-255	<b>MASTER DIMMER FINE 16BIT</b> 0-100%



6 CH	10 CH	11 CH	16 CH	48 CH	57 CH	96 CH	VALUES	FUNCTIONS
			10				000-255	<b>COLOR MACROS</b> SEE PAGES 17-18 FOR COLOR MACRO CHART
			11		52		000-010 011-026 027-043 044-060 061-076 077-093 094-110 111-126 127-143 144-160 161-176 177-193 194-210 211-226 227-255	<b>AUTO PROGRAMS</b> NO FUNCTION DREAM METEOR FADE CHANGE FLOW 1 FLOW 2 FLOW 3 FLOW 4 FLOW 5 FLOW 6 FLOW 7 FLOW 8 FLOW 9 NO FUNCTION
			12		53		000-255	<b>AUTO PROGRAM SPEED</b> SLOW - FAST
			13		54		000-255	<b>AUTO PROGRAM FADE*</b> SLOW - FAST
			14		55		000-020 021-040 041-060 061-080 081-100 101-255	<b>DIMMER MODE</b> STANDARD STAGE TV ARCHITECTURAL THEATRE DEFAULT TO UNIT SETTING
	9	10	15		56		000-015 016-030 031-045 046-060 061-075 076-090 091-105 106-120 121-135 136-150 151-165 166-180 181-195 196-210 211-225 226-255	<b>LED REFRESH RATE</b> DEFAULT TO UNIT SETTING 900HZ 1000HZ 1100HZ 1200HZ 1300HZ 1400HZ 1500HZ 2500HZ 4000HZ 5000HZ 10000HZ 15000HZ 20000HZ 25000HZ OFF
	10	11	16		57		000-020 021-040 041-060 061-080 081-100 101-120 121-255	<b>GAMMA</b> DEFAULT TO UNIT SETTING 2.0 2.2 2.4 2.6 2.8 OFF

Color No.	DMX VALUE	RGBWA+UV COLOR INTENSITY					
		RED	GREEN	BLUE	WHITE	AMBER	UV
OFF	0	0	0	0	0	0	0
Color1	1-4	80	255	234	80	0	0
Color2	5-8	80	255	164	80	0	0
Color3	9-12	77	255	112	77	0	0
Color4	13-16	117	255	83	83	0	0
Color5	17-20	160	255	77	77	0	0
Color6	21-24	223	255	83	83	0	0
Color7	25-28	255	243	77	77	0	0
Color8	29-32	255	200	74	74	0	0
Color9	33-36	255	166	77	77	0	0
Color10	37-40	255	125	74	74	0	0
Color11	41-44	255	97	77	74	0	0
Color12	45-48	255	71	77	71	0	0
Color13	49-52	255	83	134	83	0	0
Color14	53-56	255	93	182	93	0	0
Color15	57-60	255	96	236	96	0	0
Color16	61-64	238	93	255	93	0	0
Color17	65-68	196	87	255	87	0	0
Color18	69-72	150	90	255	90	0	0
Color19	73-76	100	77	255	77	0	0
Color20	77-80	77	100	255	77	0	0
Color21	81-84	67	148	255	67	0	0
Color22	85-88	77	195	255	77	0	0
Color23	89-92	77	234	255	77	0	0
Color24	93-96	158	255	144	144	0	0
Color25	97-100	255	251	153	153	0	0
Color26	101-104	255	175	147	147	0	0
Color27	105-108	255	138	186	138	0	0
Color28	109-112	255	147	251	147	0	0
Color29	113-116	151	138	255	138	0	0
Color30	117-120	100	138	255	138	0	0
Color31	121-124	138	169	255	138	0	0
Color32	125-128	255	255	255	255	0	0

Color No.	DMX VALUE	RGBWA+UV COLOR INTENSITY					
		RED	GREEN	BLUE	WHITE	AMBER	UV
Color33	129-132	255	206	143	0	0	0
Color34	133-136	254	177	153	0	0	0
Color35	137-140	254	192	138	0	0	0
Color36	141-144	254	165	98	0	0	0
Color37	145-148	254	121	0	0	0	0
Color38	149-152	176	17	0	0	0	0
Color39	153-156	96	0	11	0	0	0
Color40	157-160	234	139	171	0	0	0
Color41	161-164	224	5	97	0	0	0
Color42	165-168	175	77	173	0	0	0
Color43	169-172	119	130	199	0	0	0
Color44	173-176	147	164	212	0	0	0
Color45	177-180	88	2	163	0	0	0
Color46	181-184	0	38	86	0	0	0
Color47	185-188	0	142	208	0	0	0
Color48	189-192	52	148	209	0	0	0
Color49	193-196	0	46	35	0	0	0
Color50	197-200	8	107	222	0	0	0
Color51	201-204	107	156	231	0	0	0
Color52	205-208	165	198	247	0	0	0
Color53	209-212	0	83	115	0	0	0
Color54	213-216	0	97	166	0	0	0
Color55	217-220	1	100	167	0	0	0
Color56	221-224	0	40	86	0	0	0
Color57	225-228	209	219	182	0	0	0
Color58	229-232	42	165	85	0	0	0
Color59	233-236	255	0	0	0	0	0
Color60	237-240	0	255	0	0	0	0
Color61	241-244	0	0	255	0	0	0
Color62	245-248	0	0	0	255	0	0
Color63	249-252	0	0	0	0	255	0
Color64	253-255	0	0	0	0	0	255

MENU	SUBMENU	OPTIONS/VALUES (DEFAULT SHADED)	DESCRIPTION	
<b>Display Menu</b>	Update Wait ADJ V1.08			
<b>Set ADDR</b>	Set ADDR XXX	001~509	DMX Addressing	
<b>User Mode</b>	CHXX	6/10/11/16/48/57/96	DMX Channel Modes	
<b>Function</b>	DimCurve	Standard/Stage/TV/Architec/Theatre	Dimmer Curve Setting	
	NODMX	Hold/Blackout/Program	DMX Lost Setting	
	AUTO RUN FQN: XX	01~99	Auto Run Programs	
	1. STATC	R/G/B/RG/GB/RB/RGB/BLAC F000-255	Static Color Mode	
	2. CHANG	15 Color Change SP01-99 F000-255	15 Color Change Mode	
	3. CHANG	30 Color Change SP01-99 F000-255	30 Color Change Mode	
	4. FADE	Color Fade SP01-99 F000-255	Color Fade Mode	
	Macros 00	00~63	Color Macro Mode	
	LCD.Set	Backlight Key Lock DisFlash	05~60m ON/ON1/OFF ON/OFF	LCD Display Settings
	DFSET OFF	ON/OFF	Default Reset	
	TEMP Fahren	Fahren Celsius	Temperature Display Setting	
	Settings WhiteBal	Red: 000-255 Green: 000-255 Blue: 000-255 White: 000-255 Amber: 000-255 UV: 000-255	White Balance Setting	
	Fan Mode	Auto / Low / High	Fan Setting	
Fre_hz	900/1000/1100/1200/1300/1400/1500/2500/4000/ 5000/10k /15k /20k /25k	Set LED Refresh Rate		
Gamma	2.0 / 2.2 / 2.4 / 2.6 / 2.8	Set Gamma Brightness		
<b>Info</b>	Info TimeInfo	Current TotalTim LastClea TimerPIN	Current Running Time (Hours) Total Running Time (Hours) Last Time The Running Time Was Cleared (Hours) Current Time Clear: (Password=050) Total Time Clear: (Password=060)	
	Info TemplInfo	XXX	Current Running Temperature	
	Info Model Inf	32 Hex Panel	Model Name	
	Info Software	UXXX	Current Software Version	

MENU	SUBMENU	OPTIONS/VALUES (DEFAULT SHADED)	DESCRIPTION
<b>Slave</b>	Slave		Slave Setting
<b>Manual</b>	Manual	Manual	Manual Control
	Dimmer 000~255	Red5 000~255 Green5 000~255	
	Manual	Blue5 000~255 White5 000~255	
	AllRed 000~255	Amber5 000~255 UV5 000~255	
	AllGreen 000~255	Manual	
	AllBlue 000~255	Red6 000~255 Green6 000~255	
	AllWhite 000~255	Blue6 000~255 White6 000~255	
	AllAmber 000~255	Amber6 000~255 UV6 000~255	
	AllUV 000~255	Manual	
	Manual	Red7 000~255 Green7 000~255	
	Red1 000~255	Blue7 000~255 White7 000~255	
	Green1 000~255	Amber7 000~255 UV7 000~255	
	Blue1 000~255	Manual	
	White1 000~255	Red8 000~255 Green8 000~255	
	Amber1 000~255	Blue8 000~255 White8 000~255	
	UV1 000~255	Amber8 000~255 UV8 000~255	
	Manual	Manual	
	Red2 000~255	Red8 000~255 Green8 000~255	
	Green2 000~255	Blue8 000~255 White8 000~255	
	Blue2 000~255	Amber7 000~255 UV7 000~255	
	White2 000~255	Manual	
	Amber2 000~255	Red8 000~255 Green8 000~255	
	UV2 000~255	Blue8 000~255 White8 000~255	
	Manual	Amber8 000~255 UV8 000~255	
	Red3 000~255	Manual	
	Green3 000~255	Strobing 000~255	
	Blue3 000~255		
	White3 000~255		
	Amber3 000~255		
	UV3 000~255		
	Manual		
	Red4 000~255		
Green4 000~255			
Blue4 000~255			
White4 000~255			
Amber4 000~255			
UV4 000~255			

**DMX Addressing:**

Operating through a DMX controller gives the user the freedom to create their own programs tailored to their own individual needs.

1. To run your fixture in DMX mode press the MODE button and press the UP or DOWN buttons until “**Set Addr**” is displayed and press ENTER. The current DMX address will now be displayed.
2. Use the UP or DOWN buttons to find your desired DMX address, and press ENTER.

**DMX Channel Modes** - With this function, you can select your desired DMX channel mode. The 32 Hex Panel IP/32 Hex Panel IP Pearl has 7 DMX channel modes: 6/10/11/16/48/57/96.

1. Press the MODE button to access the main menu. Press the UP or DOWN buttons until “**User Mode**” is displayed and press ENTER. The current DMX channel mode will now be displayed.
2. Press the UP or DOWN buttons to scroll through the 7 DMX channel modes. When you have found your desired DMX channel mode, press ENTER to confirm your selection or press the MODE button to exit. Please see pages 12-16 for the DMX modes, values, and traits.

**Dimmer Curve Setting:**

1. Press the MODE button to access the main menu. Press the UP or DOWN buttons until “**Menu Function**” is displayed, and press ENTER. Press the UP or DOWN buttons until “**DimCurve**” is displayed, and press ENTER.
2. Use the UP or DOWN buttons to scroll through the dimmer curves. Press ENTER to confirm your selection or press the MODE button to exit.
3. There are 5 dimmer curve settings to choose from. Please see the Dimmer Curve Diagram Chart on page 26 to see the settings and their respective beginning and ending fade times.

**DMX Lost Setting:**

This mode is used as a precaution mode, that in case the DMX signal is lost, the operating mode chosen in the setup is the running mode the fixture will go into when the DMX signal is lost. You can also set this as the operating mode you would like the unit to return to when power is applied.

1. Press the MODE button to access the main menu. Press the UP or DOWN buttons until “**Menu Function**” is displayed, and press ENTER. Press the UP or DOWN buttons until “**NODMX**” is displayed and press ENTER.
2. Use the UP and DOWN buttons to scroll through the 3 DMX standing states.
  - “**Hold**” - If the DMX signal is lost or interrupted, the fixture will stay in the last DMX set up. If power is applied and this mode is set, the unit will automatically go into the last DMX set up.
  - “**Blackout**” - If the DMX signal is lost or interrupted, the unit will automatically go into stand by mode.
  - “**Program**” - If the DMX signal is lost or interrupted, the unit will automatically go into Auto Run mode.
3. Use the UP and DOWN buttons to find your desired DMX state and press ENTER to confirm your selection or press the MODE button to exit.

**Auto Run Mode:**

1. Press the MODE button to access the main menu. Press the UP or DOWN buttons so that “**Menu Function**” is displayed, and press ENTER. Press the UP or DOWN buttons until “**AUTO RUN FQN**” is displayed and press ENTER.
2. Use the UP or DOWN buttons to scroll through the 99 Auto Run programs. Press ENTER to confirm your selection or press the MODE button to exit.

**Static Color Mode, Color Change Mode, and Color Fade Mode:**

1. Press the MODE button to access the main menu. Press the UP or DOWN buttons so that “**Menu Function**” is displayed and press ENTER. Press the UP or DOWN buttons until **ONE** of the following running modes is displayed:
  - “**1. STATC**” - Static Color Mode (Color adjustment and strobing)
  - “**2. CHANG**” - 15 Color Change Mode (Color changing, change speed adjustment, & strobing)
  - “**3. CHANG**” - 30 Color Change Mode (Color changing, change speed adjustment, & strobing)
  - “**4. FADE**” - Color Fade Mode (Color fading, fade speed adjustment, & strobing)

**Note: See the System Menu on page 19.**

2. Press the ENTER button to select your desired running mode. Use the UP and DOWN buttons to make your desired adjustments. Press the ENTER button each time you are finished making adjustments in the current running mode.

**Color Macro Mode:**

1. Press the MODE button to access the main menu. Press the UP or DOWN buttons until “**Menu Function**” is displayed, and press ENTER.
2. Press the UP or DOWN buttons until “**Macros**” is displayed and press ENTER.
3. There are 63 colors to choose from. Use the UP and DOWN buttons for find your desired color.
4. Once you have found your desired color press the ENTER button. Press the MODE button to exit.

**LCD Display Settings:**

1. Press the MODE button to access the main menu. Press the UP or DOWN buttons until “**Menu Function**” is displayed, and press ENTER.
2. Press the UP or DOWN buttons until “**LCD.Set**” is displayed and press ENTER.
3. Use the UP and DOWN buttons to scroll through the options, and press ENTER to make your selection.
  - **Backlight** - This lets you set how long the backlight display will stay on.
  - **Key Lock** - This lets you control the key lock feature.
    - “**OFF**” - The keypad is unlocked, simply press the MODE button to activate the keypad.
    - “**ON**” - This is a simple keypad lock. “**LOCKED \*\*\*\*\***” will be displayed. Press the MODE button for at least 5 seconds to unlock the keypad.
    - “**ON1**” - This setting is used to prevent the accidental unlocking of the keypad. To unlock the keypad you will have to enter a passcode. “**LOCKED \*\*\*\*\***” will be displayed. To unlock the keypad press UP, DOWN, UP, DOWN, & ENTER in that order. Every press of these buttons will delete an asterisk.
  - **DisFlash** - In this function you can activate the display flash.

**Default Running Mode:**

In this mode you can reset all function settings to their default modes.

1. Press the MODE button to access the main menu. Press the UP or DOWN buttons until “**Menu Function**” is displayed and press ENTER.
2. Press the UP or DOWN buttons until “**DFSET**” displayed, and press ENTER.
3. Use the UP or DOWN button to toggle between “**ON**” and “**OFF**”. To reset to the default settings, select “**ON**” and press ENTER.

**Unit Temperature** - With this function you can switch the temperature setting between celsius or fahrenheit.

1. Press the MODE button to access the main menu. Press the UP or DOWN buttons until “**Menu Function**” is displayed and press ENTER.
2. Press the UP or DOWN buttons until “**Temp**” is displayed and press ENTER.
3. Use the UP and DOWN buttons to switch between “**Fahren**” and “**Celsius**”.
4. Once you have found your desired setting press ENTER to confirm, or press MODE to exit.

**White Balance Settings** - With this function you can adjust RGBWA & UV colors to balance the white color.

1. Press the MODE button to access the main menu. Press the UP or DOWN buttons until “**Menu Function**” is displayed and press ENTER.
2. Press the UP or DOWN buttons until “**Settings WhiteBal**” is displayed and press ENTER.
3. Use the UP and DOWN buttons to switch between the colors. When you have found the color you wish to adjust press ENTER. Use the UP or DOWN button to adjust the color values.
4. Once you have made your desired adjustment press ENTER.

**Fan Setting** - With this function you can adjust the fan speeds.

1. Press the MODE button to access the main menu. Press the UP or DOWN buttons until “**Menu Function**” is displayed and press ENTER.
2. Press the UP or DOWN buttons until “**Fan Mode**” is displayed and press ENTER.
3. Use the UP and DOWN buttons to scroll through different frequencies.
4. Once you have found your desired frequency press ENTER.

**Frequency Setting** - With this function you can adjust the dimming frequency.

1. Press the MODE button to access the main menu. Press the UP or DOWN buttons until “**Menu Function**” is displayed and press ENTER.
2. Press the UP or DOWN buttons until “**Fre\_hz**” is displayed and press ENTER.
3. Use the UP and DOWN buttons to scroll through different frequencies.
4. Once you have found your desired frequency press ENTER.

**Gamma Brightness Setting** - With this function you can adjust the gamma brightness.

1. Press the MODE button to access the main menu. Press the UP or DOWN buttons until “**Menu Function**” is displayed and press ENTER.
2. Press the UP or DOWN buttons until “**Gamma**” is displayed and press ENTER.
3. Use the UP and DOWN buttons to scroll through different settings.
4. Once you have found your desired setting press ENTER.

#### **Time Information:**

1. Press the MODE button to access the main menu. Press the UP or DOWN buttons until “**Menu Info**” is displayed and press ENTER.
2. Press the UP or DOWN buttons until “**TimeInfo**” is displayed and press ENTER.
3. Use the UP and DOWN buttons to scroll through the time information menu.
  - “**TimeInfo Current**” - This will display the current running time of the fixture in hours.
  - “**TimeInfo TotalTim**” - This will display the total running time of the fixture in hours.
  - “**TimeInfo LastClea**” - This will display the last time the running time was cleared.
  - “**TimeInfo TimerPIN**” - This menu function will allow you to clear the current running time and total running time.



**Temperature Information:**

1. Press the MODE button to access the main menu. Press the UP or DOWN buttons until “**Menu Info**” is displayed and press ENTER.
2. Press the UP or DOWN buttons until “**TempInfo**” is displayed and press ENTER.
3. The current temperature will now be displayed. Press the MENU button to exit.

**Model Information:**

1. Press the MODE button to access the main menu. Press the UP or DOWN buttons until “**Menu Info**” is displayed and press ENTER.
2. Press the UP or DOWN buttons until “**Model Inf**” is displayed and press ENTER.
3. The model name will now be displayed. Press the MENU button to exit.

**Software Information:**

1. Press the MODE button to access the main menu. Press the UP or DOWN buttons until “**Menu Info**” is displayed and press ENTER.
2. Press the UP or DOWN buttons until “**Software**” is displayed and press ENTER.
3. The current software version will now be displayed. Press the MENU button to exit.

**Slave Setting** - With this function you can set the unit as a “Slave” in Master-Slave configuration.

1. Plug the fixture in and press the MODE button and press the UP or DOWN buttons until “**Slave**” is displayed, and press ENTER.
2. The unit is now set as a “Slave” in a Master-Slave configuration.

**Manual Control** - With this function you can manually adjust the dimmer, colors, and strobing.

1. Plug the fixture in and press the MODE button and press the UP or DOWN buttons until “**Manual**” is displayed, and press ENTER.
2. Press the UP or DOWN buttons to scroll through dimmer, colors, and strobe.

**Note: See the system menu on page 20.**

3. Press ENTER to select the function you would like to adjust and use the UP and DOWN buttons to make the adjustments.
4. Once you have made your desired adjustments, press the ENTER button.

**Master-Slave Configuration:**

This function will allow you to link units together to run in a Master-Slave set-up. In a Master-Slave set up one unit will act as the controlling unit and the others will react to the controlling units built-in programs. Any unit can act as a Master or as a Slave however, only one unit can be programmed to act as the “Master.”

**Master-Slave Connections and Settings:**

1. Daisy chain your units via the XLR connector on the rear of the unit. Use standard XLR data cables to link your units together. Remember that the Male XLR connector is the input and the Female XLR connector is the output. The first unit in the chain (master) will use the female XLR connector only. The last unit in the chain will use the male XLR connector only.
2. Connect the first “Slave” unit to the “Master.”
3. Set the “Master” unit to your desired mode of operation. On the “Slave” unit(s) press the MODE button and press the UP or DOWN buttons until “**Slave**” is displayed and press ENTER.
4. The slave unit(s) will now follow the master unit.

Pixel Zones 1-8

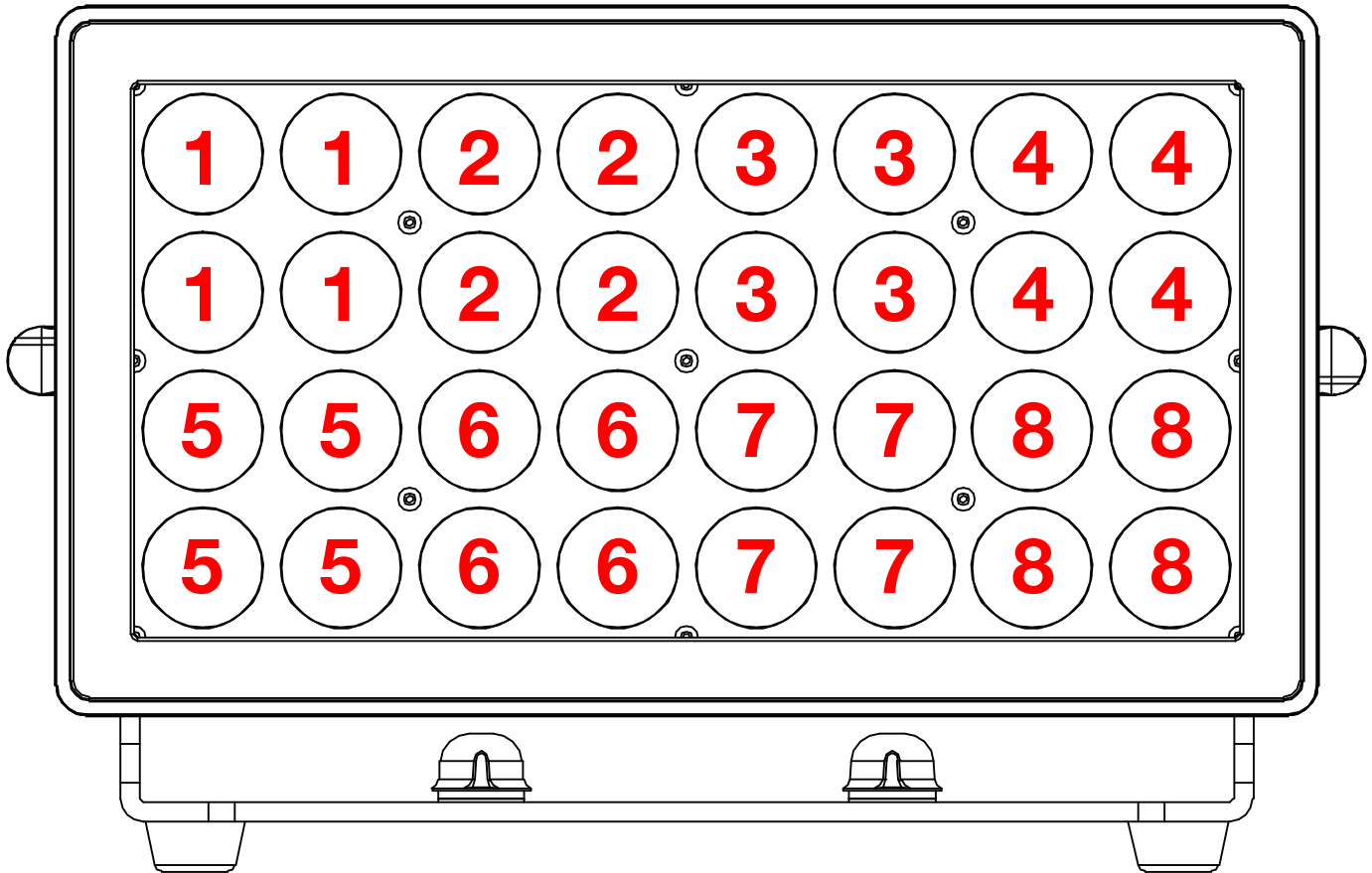

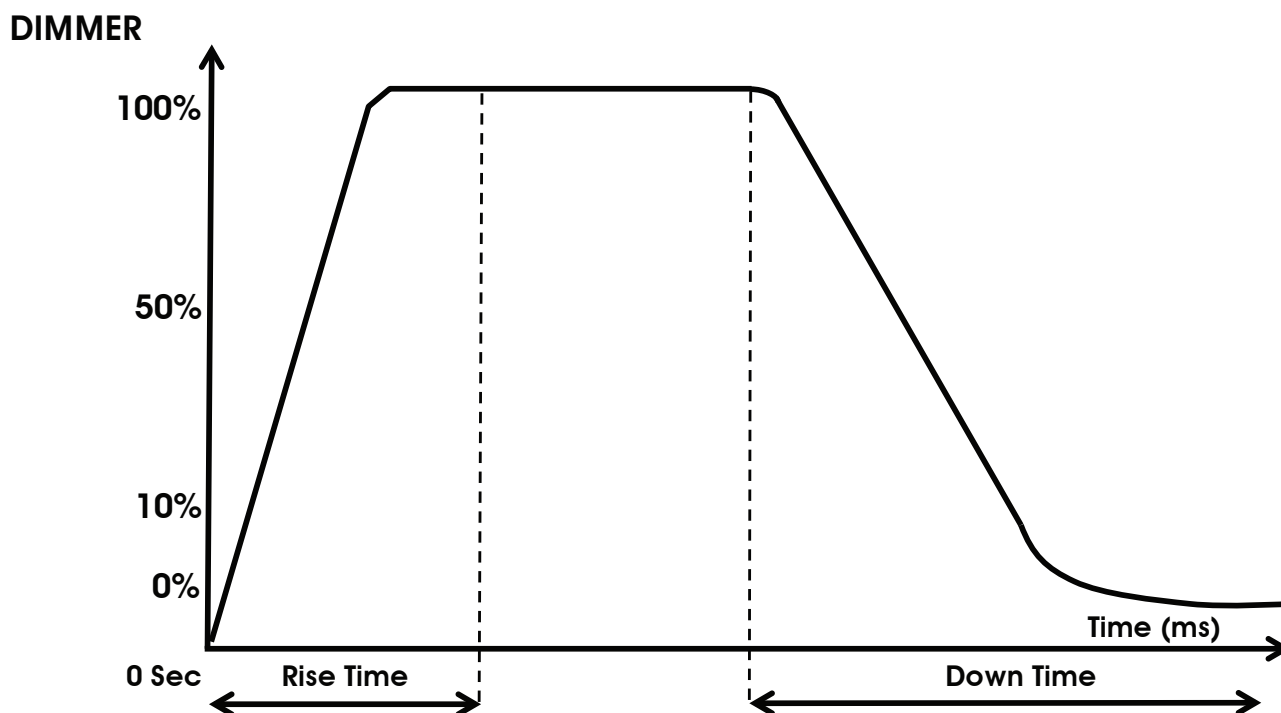

Dimming Curve Ramp Effect	0 sec Fade Time		1 sec Fade Time	
	Rise Time (ms)	Down Time (ms)	Rise Time (ms)	Down Time (ms)
Standard (default)	0	0	0	0
Stage	780	1100	1540	1660
TV	1180	1520	1860	1940
Architectural	1380	1730	2040	2120
Theatre	1580	1940	2230	2280

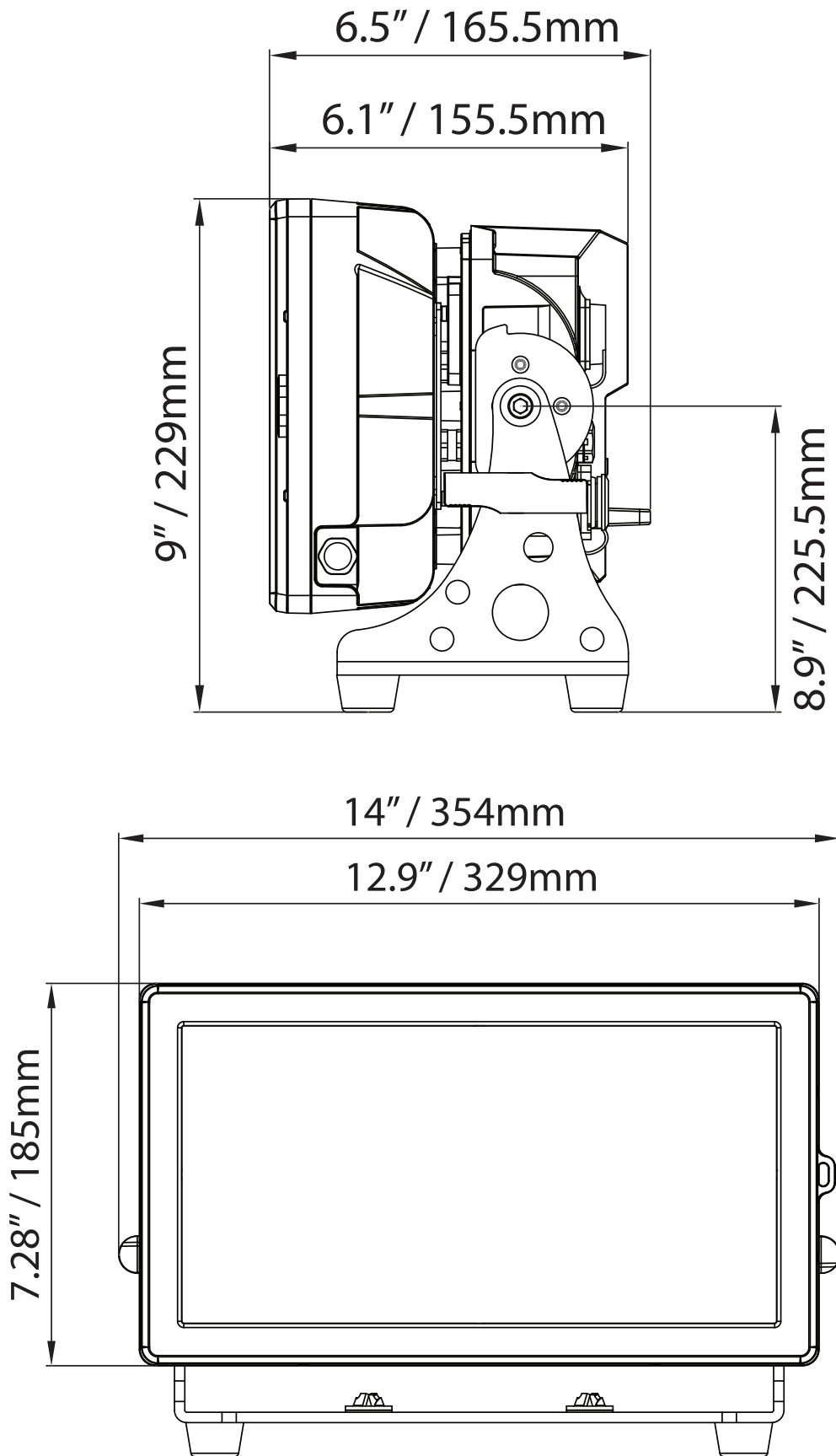

## Barn Doors Not Included

1. Install and secure the included magnetic LED array cover. **(Note: Not required when using Barn Doors)**

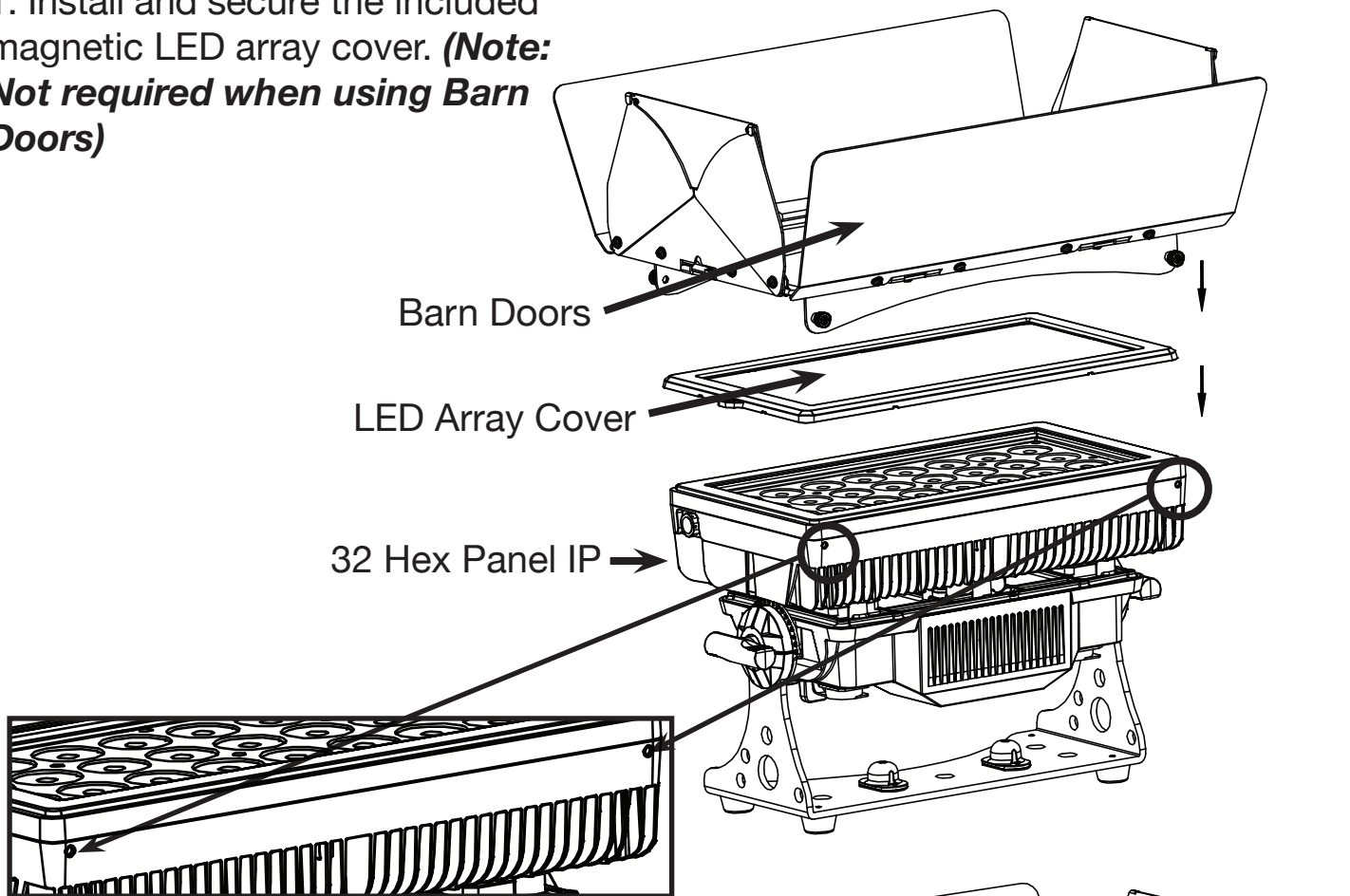

2. Place the Barn Door attachment over the front of the unit. Line up the 4 Barn Door thumb screws with the thumb screw holes located on each side of unit (2 on each side). Screw thumb screws in and tighten. **DO NOT** overtighten.

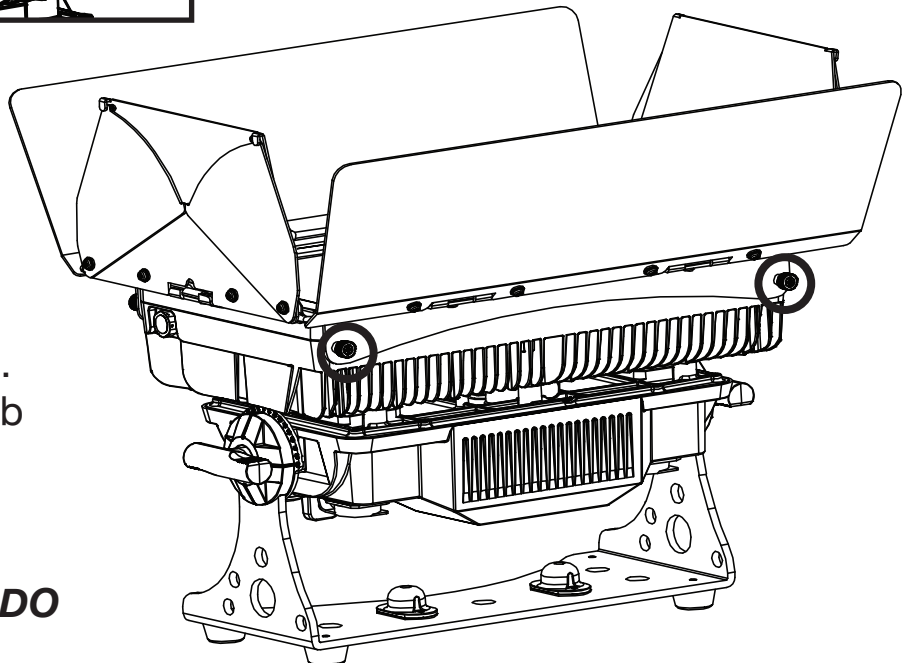

# 32 Hex Panel IP/32 Hex Panel IP Pearl Barn Door Dimensional Drawings

Barn Doors Not Included

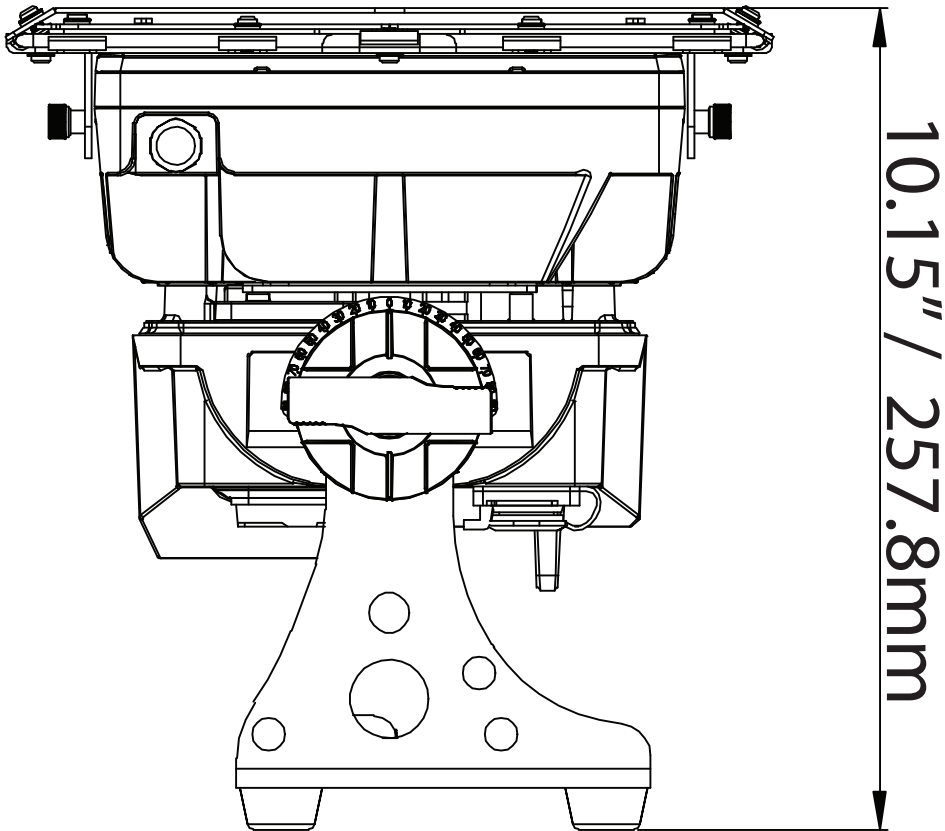
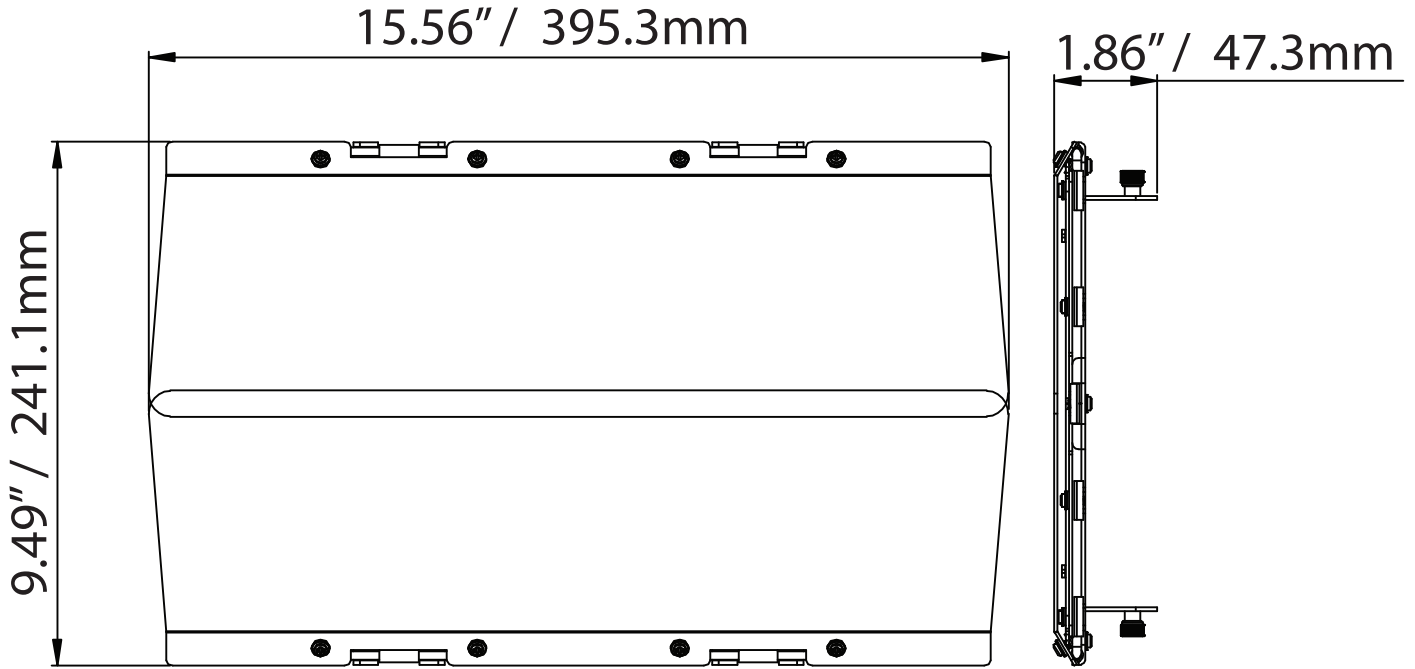

With this feature you can connect the fixtures to one another using the power cable input and output sockets.

**NOTE: USE CAUTION WHEN POWER LINKING OTHER FIXTURES AS THE POWER CONSUMPTION OF OTHER MODEL FIXTURES MAY EXCEED THE MAX POWER OUTPUT ON THIS FIXTURE! CHECK SILK SCREEN FOR MAX AMPS.**

Listed below are a few common problems the user may encounter, with solutions.

***Unit not responding to DMX:***

1. Check that the DMX cables are connected properly and are wired correctly (pin 3 is “hot”; on some other DMX devices pin 2 may be ‘hot’). Also, check that all cables are connected to the right connectors; it does matter which way the inputs and outputs are connected.

Due to fog residue, smoke, and dust cleaning the internal and external optical lenses must be carried out periodically to optimize light output.

1. Use normal glass cleaner and a soft cloth to wipe down the outside casing.
2. Clean the external optics with glass cleaner and a soft cloth every 20 days.
3. Always be sure to dry all parts completely before plugging the unit back in.

Cleaning frequency depends on the environment in which the fixture operates (i.e. smoke, fog residue, dust, dew).

**MANUFACTURER'S LIMITED WARRANTY**

- A. ADJ Products, LLC hereby warrants, to the original purchaser, ADJ Products, LLC products to be free of manufacturing defects in material and workmanship for a prescribed period from the date of purchase (see specific warranty period on reverse). This warranty shall be valid only if the product is purchased within the United States of America, including possessions and territories. It is the owner's responsibility to establish the date and place of purchase by acceptable evidence, at the time service is sought.
- B. For warranty service you must obtain a Return Authorization number (RA#) before sending back the product—please contact ADJ Products, LLC Service Department at 800-322-6337. Send the product only to the ADJ Products, LLC factory. All shipping charges must be pre-paid. If the requested repairs or service (including parts replacement) are within the terms of this warranty, ADJ Products, LLC will pay return shipping charges only to a designated point within the United States. If the entire instrument is sent, it must be shipped in its original package. No accessories should be shipped with the product. If any accessories are shipped with the product, ADJ Products, LLC shall have no liability whatsoever for loss of or damage to any such accessories, nor for the safe return thereof.
- C. This warranty is void if the serial number has been altered or removed; if the product is modified in any manner which ADJ Products, LLC concludes, after inspection, affects the reliability of the product; if the product has been repaired or serviced by anyone other than the ADJ Products, LLC factory unless prior written authorization was issued to purchaser by ADJ Products, LLC; if the product is damaged because not properly maintained as set forth in the instruction manual.
- D. This is not a service contract, and this warranty does not include maintenance, cleaning or periodic check up. During the period specified above, ADJ Products, LLC will replace defective parts at its expense with new or refurbished parts, and will absorb all expenses for warranty service and repair labor by reason of defects in material or workmanship. The sole responsibility of ADJ Products, LLC under this warranty shall be limited to the repair of the product, or replacement thereof, including parts, at the sole discretion of ADJ Products, LLC. All products covered by this warranty were manufactured after August 15, 2012, and bear identifying marks to that effect.
- E. ADJ Products, LLC reserves the right to make changes in design and/or improvements upon its products without any obligation to include these changes in any products theretofore manufactured.

No warranty, whether expressed or implied, is given or made with respect to any accessory supplied with products described above. Except to the extent prohibited by applicable law, all implied warranties made by ADJ Products, LLC in connection with this product, including warranties of merchantability or fitness, are limited in duration to the warranty period set forth above. And no warranties, whether expressed or implied, including warranties of merchantability or fitness, shall apply to this product after said period has expired. The consumer's and/or Dealer's sole remedy shall be such repair or replacement as is expressly provided above; and under no circumstances shall ADJ Products, LLC be liable for any loss or damage, direct or consequential, arising out of the use of, or inability to use, this product.

This warranty is the only written warranty applicable to ADJ Products, LLC Products and supersedes all prior warranties and written descriptions of warranty terms and conditions heretofore published.

**MANUFACTURER'S LIMITED WARRANTY PERIODS:**

- **Non L.E.D. Lighting Products = 1-year (365 days) Limited Warranty** (Such as: Special Effect Lighting, Intelligent Lighting, UV lighting, Strobes, Fog Machines, Bubble Machines, Mirror Balls, Par Cans, Trussing, Lighting Stands etc. excluding LED and lamps)
- **Laser Products = 1 Year (365 Days) Limited Warranty** (excluding laser diodes which have a 6 month limited warranty)
- **L.E.D. Products = 2-year (730 days) Limited Warranty** (excluding batteries which have a 180 day limited warranty). **Note: 2 Year Warranty only applies to purchases within the United States.**
- **StarTec Series = 1 Year Limited Warranty** (excluding batteries which have a 180 day limited warranty).
- **ADJ DMX Controllers = 2 Year (730 Days) Limited Warranty**



**Model: 32 Hex Panel IP/  
32 Hex Panel IP Pearl**

Voltage:	100V ~ 240V/50~60Hz
LEDs:	32 x 12W 6-in-1 HEX LED's
IP Rating:	IP65
Working Position:	Any safe working position
Power Draw:	298W
Dimensions:	6.5" (L) x 14" (W) x 9" (H) 165.5 x 354 x 229mm
Weight:	24.25lbs. / 11kg
Colors:	RGBWA+UV Color Mixing
DMX Channels:	7 DMX Modes: 6/10/11/16/48/57/96
Warranty:	2 Year (730 days)

**Please Note:** Specifications and improvements in the design of this unit and this manual are subject to change without any prior written notice.