

Electric Guitar Amplifiers

VIRTUBE VT250FX/VT100FX/VT100FXH VT50FX/VT30FX/VT15FX/VT15CD

Two-Channel Guitar Amplifiers with hi-quality FX, VTC Tube Modeling and Original BUGERA Speakers

- Powerful 2-channel guitar amplifiers with authentic VTC Tube Modeling: VT15FX 15-Watts, VT15CD 15-Watts, VT30FX 30-Watts, VT50FX 60-Watts, VT100FX 100-Watts, VT100FXH 100-Watts, VT250FX 2 X 50-Watts Stereo
- Awesome digital FX processor with reverb, chorus, flanger and delay
- FX loop for external effects devices (rack effects, stomp boxes, wah-wah pedals, etc.) (VT50FX, VT100FX, VT100FXH and VT250FX only)
- Original heavy-duty BUGERA vintage guitar speakers for classic sound reproduction
- 2 full-featured channels offering everything you need from clean to super-fat distortion sounds
- 2 switchable modes on each channel: Clean/Crunch on the Clean and OD1/OD2 on the Overdrive channel (VT100FX, VT100FXH only)
- Radical bass, mid and treble controls — for every sound from traditional to scooped modern (VT15FX & VT15CD, only)
- Independent Bass and Treble tone controls on each channel for awesome sound shaping (VT30FX, VT50FX, VT100FX, VT100FXH, VT250FX only)
- Contour control for radical midrange sweep—from traditional to scooped modern (VT30FX, VT50FX, VT100FX, VT100FXH, VT250FX)



Where are the tubes?

Ask any guitarist what they want most from an amp and they'll answer with a single word — TONE. That quest for tone drove us to develop our family of VIRTUBE amplifiers. Our proprietary VTC (Virtual Tube Circuitry) gives these amazing amps their in-your-face tube-amp tone. Amps with such rich, harmonic character and buttery tube-like goodness, you'll wonder where we hid the tubes.

All VIRTUBE amps have split-personalities: one that features dulcet-clean output, and one that drives your tone with an aggressive punch that only tubes, or our VTC modeling, can generate. So when the time comes,

you'll be ready for everything from mellow blues to metal mayhem.

Revolutionary VTC Technology

The secret behind VIRTUBE's incredible sound is our VTC Tube Modeling processor, which exudes the very essence of tube saturation and compression. But VTC does so much more than just generate a cheap copy of a specific amp character. It accurately emulates the interaction between classic tube stages, responding to the subtle tonal changes that occur when one stage hands the signal off the next. The resulting signal is rich in harmonic content and far more true to the nature of tube amps.

Continued on next page



VIRTUBE

VT250FX/VT100FX

VT100FXH/VT50FX

VT30FX/VT15FX

VT15CD

- Additional Headphone and Line output with integrated speaker simulation
- Dedicated CD input for playback of line-level signals (e.g. CD player, drum machine)
- Dual footswitch FS112VT for Channel selection and FX bypass included (VT30FX, VT50FX, VT100FX, VT100FXH, VT250FX only)
- High-quality components and exceptionally rugged construction ensure long life
- Conceived and designed by BEHRINGER Germany

Two-Channel Operation

VIRTUBE's Clean channel is elegant in its simplicity. The sound is open and uncolored and can be tailored to your needs by Volume and the analog passive equalizer. The Overdrive channel features Gain, Volume, Bass, Treble and our proprietary Contour control, with its radical midrange sweep. All this versatility enables you to artfully define your "perfect" tone, from traditional to scooped modern and anything in-between.

Digital FX

All VIRTUBE models, with the exception of the VT15CD, come with state-of-the-art effects — and not some cheap-and-cheesy reverb chip, but a full-blown 24-bit digital effects processor with 16 great-sounding reverbs, choruses, flangers and delays. This tasty collection of effects is a must-have for any guitarist and includes room, stage, concert and cathedral reverbs, slap-back and medium echoes, two long delays, plus slow and fast modulation effects — all right at your fingertips.

Handmade Speakers

It takes a special speaker to handle all this incredible technology, tube-like tone and brutal output power. That's why we fit each VIRTUBE combo with handmade, heavy-duty BUGERA Vintage Guitar speakers. These babies were custom-designed and handcrafted specifically for the VIRTUBE Series, and are ideally suited for classic sound reproduction.

Get Connected

Whether you're recording or just jamming on your latest riff, you need the right connections — VIRTUBE really has you covered. The PHONES/LINE OUT B jack is much more than just a place for your headphones to call home. As the name implies, this jack can also be used to send your guitar signal, with speaker simulation, to another amp or mixer.* When the PHONES/ LINE OUT B jack is in use, the internal loudspeaker is muted, allowing you to crank your guitar into the wee morning hours, without bothering the neighbors.

If you'd like to play along with previously recorded tracks, just plug the output of your CD/Tape/mp3 deck into the CD IN/LINE OUT A jack. This jack also serves a second purpose, providing yet another Line Out, this time without speaker simulation.*

* Note: Use a standard ¼" TS cable to connect this line-level signal to the destination device. If a hum is detected, or the cable run is more than a few feet, you may get better results using a Direct Injection box, like our DI100 or DI20.



VIRTUBE VT250FX/VT100FX VT100FXH/VT50FX VT30FX/VT15FX VT15CD



VT15FX

Equally perfect for aspiring and for accomplished guitarists for practicing or warm-up with uncompromised sound options. Armed with 15-Watts, a custom-designed 8" BUGERA speaker, and sixteen

digital effects, including four each of the following: reverb, delay, chorus and flanger, this baby is ready to rock!

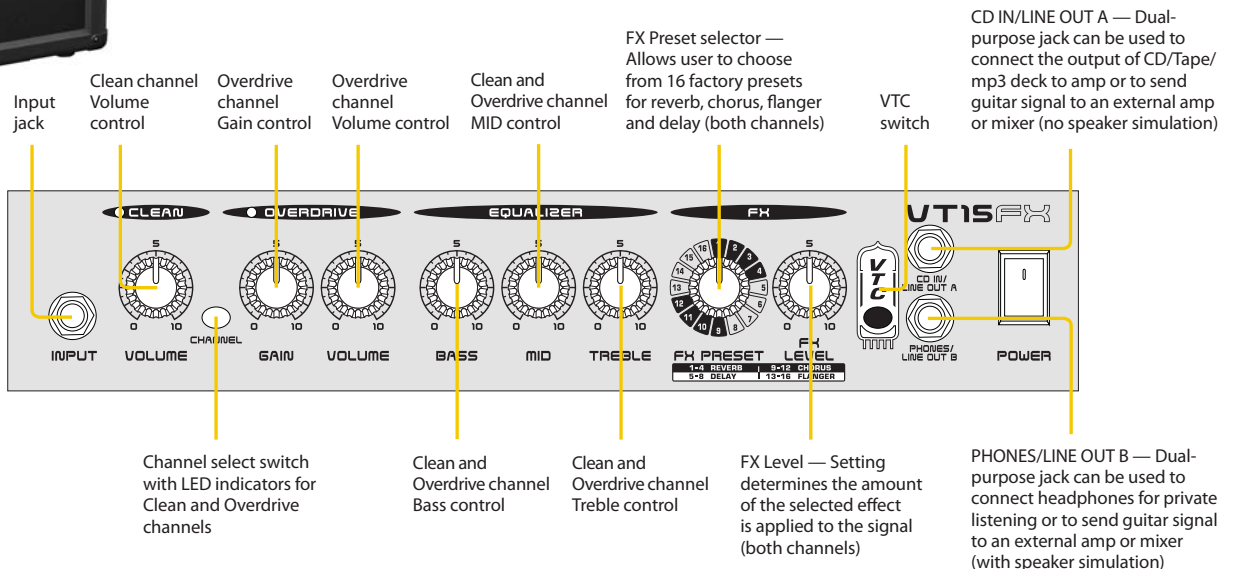

VT15CD

For the guitarist who already has a toolbox-full of their favorite effects gadgets, the VT15CD has all the features of the VT15FX, except the FX. With a

Clean channel, as well as an Overdrive channel with 3-band EQ, the VT15CD is all about tone!

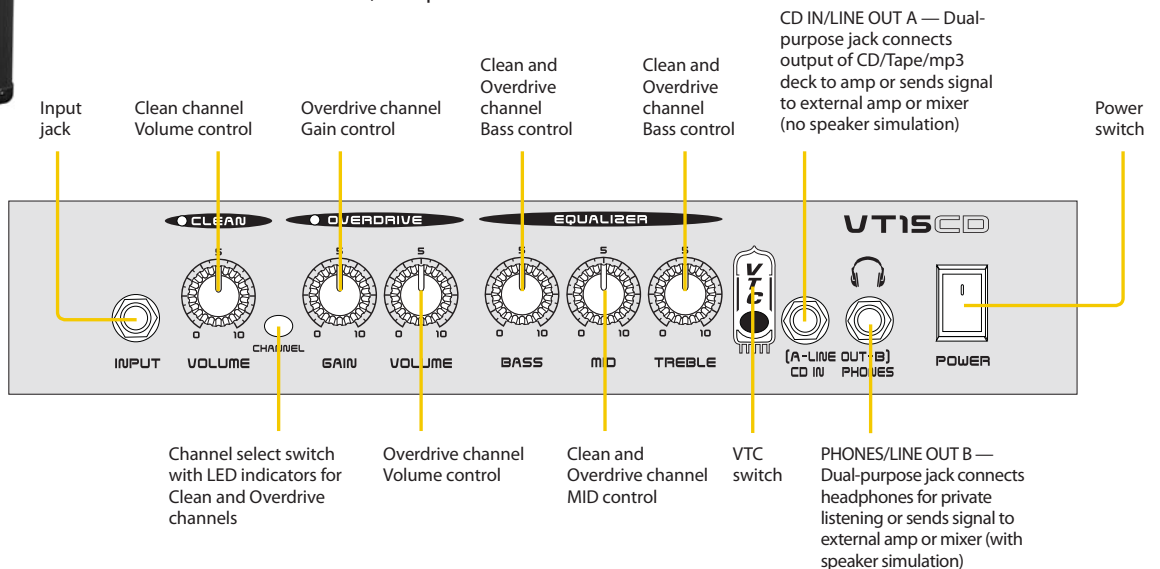

VIRTUBE VT250FX/VT100FX VT100FXH/VT50FX VT30FX/VT15FX VT15CD



VT30FX

If your gig calls for a bit more volume, may we suggest the VT30FX — with its 30-Watts of output power and rugged, vintage 10" BUGERA speaker, you will be the "Master of Tone!". You get the same great-sounding digital effects section mentioned above, which features four reverbs, four delays,

four chorus and four flanger presets — plus a footswitch for channel-switching and FX on/off. The VT30FX also includes additional tone-shaping for the Clean channel via separate, dedicated Bass and Treble controls.

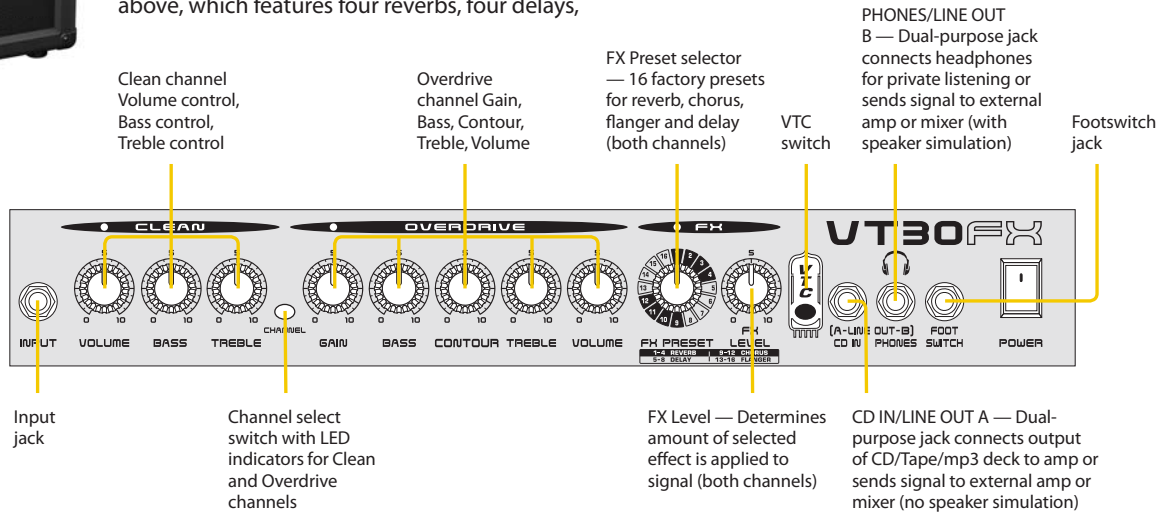

VT50FX

The VT50FX comes loaded for tone, with Bass and Treble controls on the Clean channel and a dedicated 3-band EQ, plus our radical Contour control on the Overdrive channel — allowing you to sweep the mids to dial in your perfect sound. The 16 onboard digital effects are switching on/off via the included footswitch, which also toggles between the two

channels. There's also a dedicated FX Loop so you can inject your sound with your personal favorite external effects. With 60-Watts (we know the name says 50, but we think more is always better!) and a custom-engineered 12" BUGERA speaker, the VT50FX stands out in a crowd.

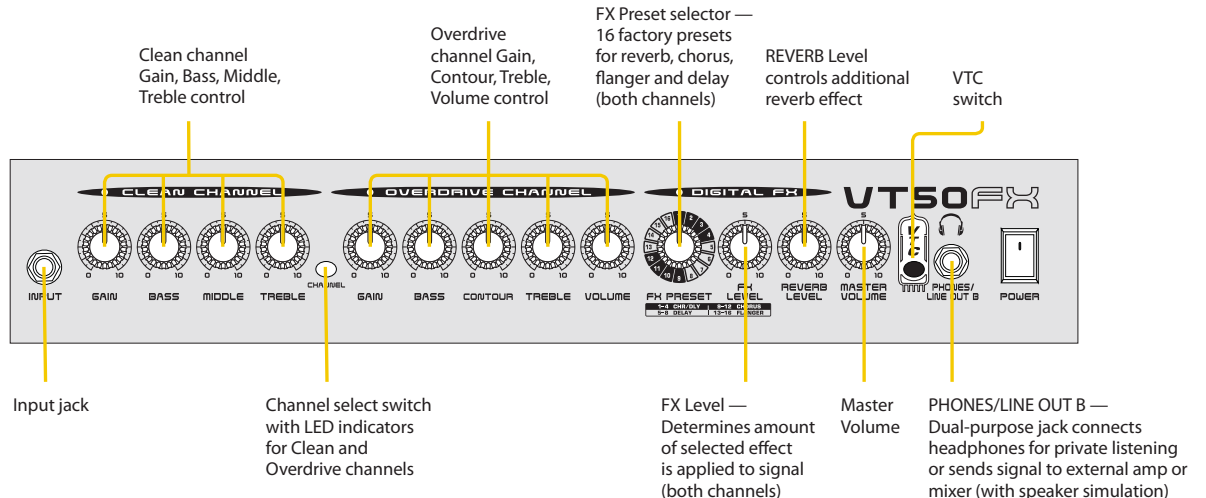

VIRTUBE VT250FX/VT100FX VT100FXH/VT50FX VT30FX/VT15FX VT15CD



VT100FX

When it comes to output power, the VT100FX brings it in truckloads. Packing a brutal 100-Watts and a special heavy-duty 12" BUGERA speaker, the VT100FX includes our radical mid-sweeping Contour control for the ultimate in tone, and an OD1/OD2 switch, which lets you choose between two unique Overdrive channel sounds. And if the sweet sound of crunch pushes all your right buttons,

press VT100FX's Crunch button for a non-stop foray into rhythmic paradise! VT100FX also has a dedicated FX Loop, so you can bring your favorite stomps and rack units to the gig — and still use the great-sounding onboard digital effects. If you prefer running a full- or half-stack, the VT100FXH offers all these features in a piggyback-style head version.

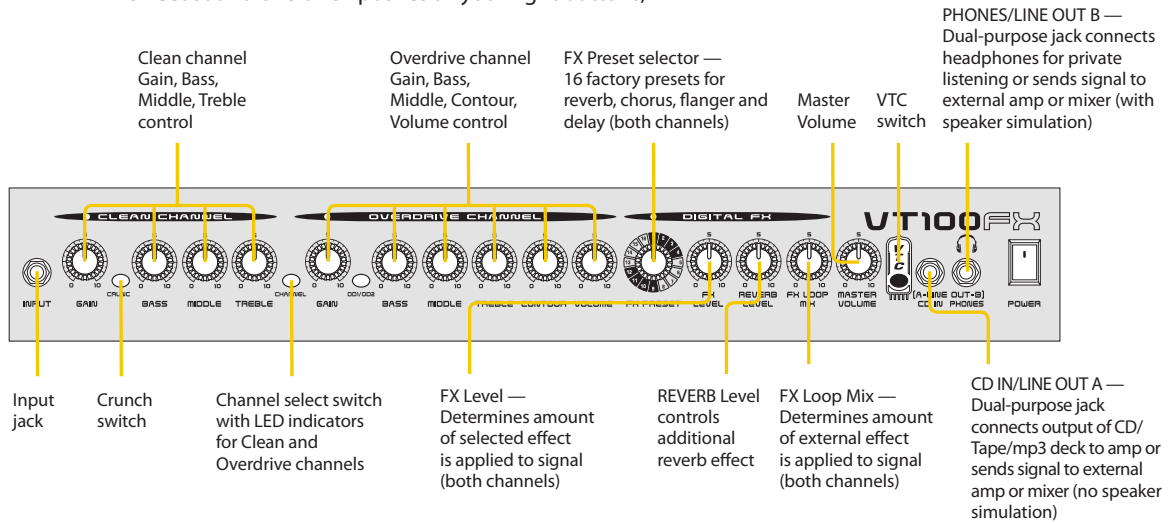

VT250FX

If the sweet sound of stereo is your thing, you'll want to check out the VT250FX — it's like having two VT50FXs in one convenient combo. Use

the dual BUGERA Vintage Series 12" speakers or send the output to a pair of half-stack cabinets if you need to really rock the house!

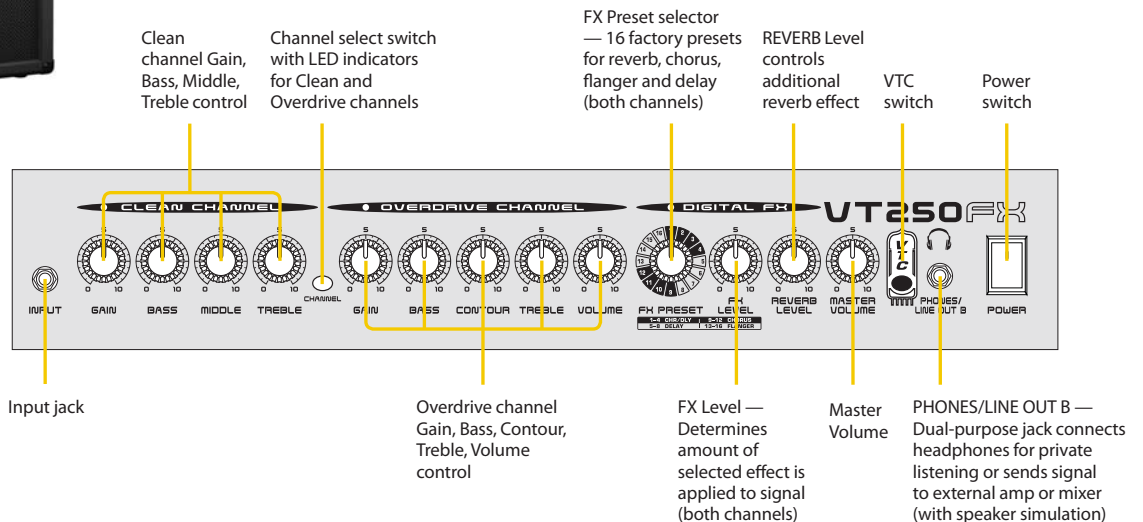

VIRTUBE VT250FX/VT100FX VT100FXH/VT50FX VT30FX/VT15FX VT15CD

VT50FX/VT100FX/VT100FXH/VT250FX Rear Panel

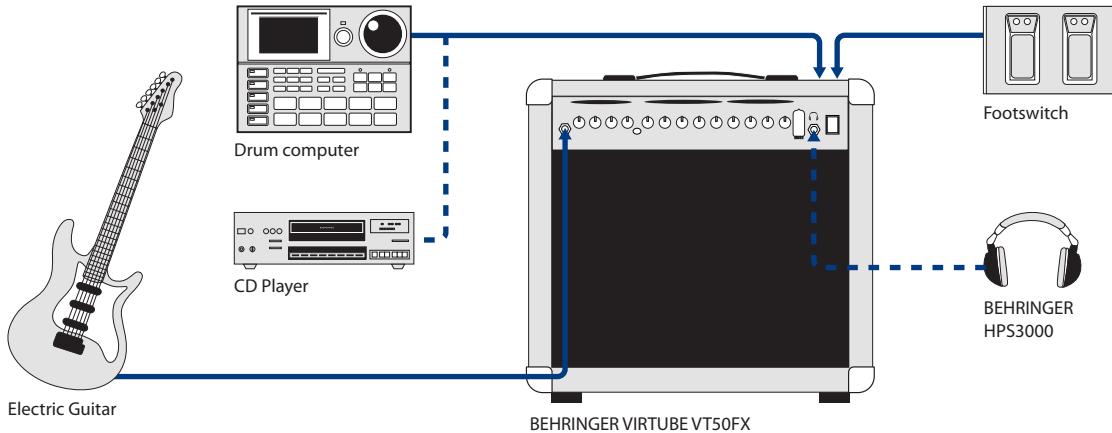
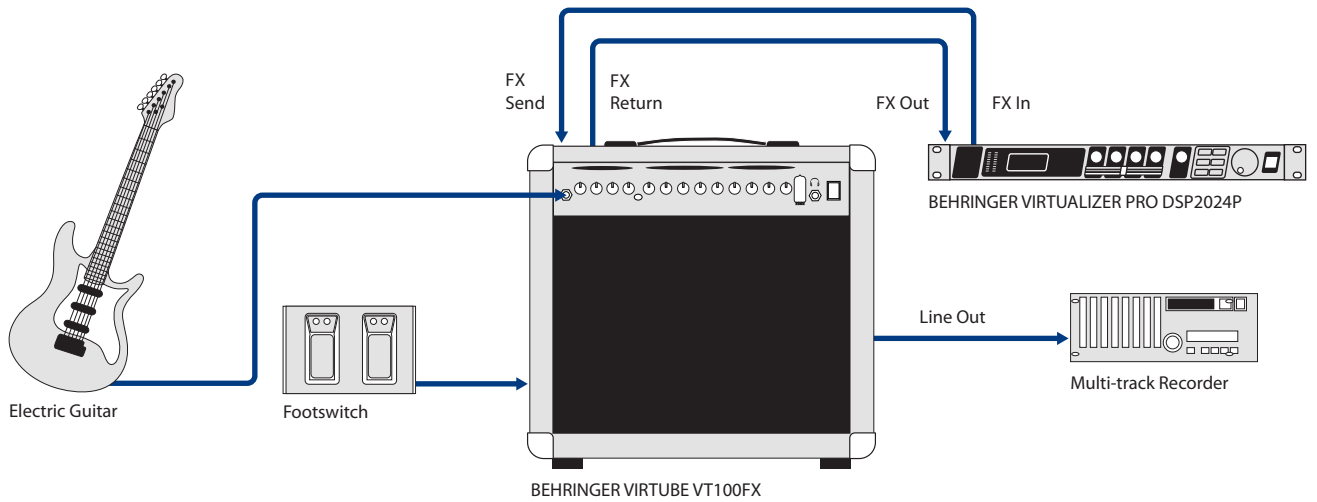
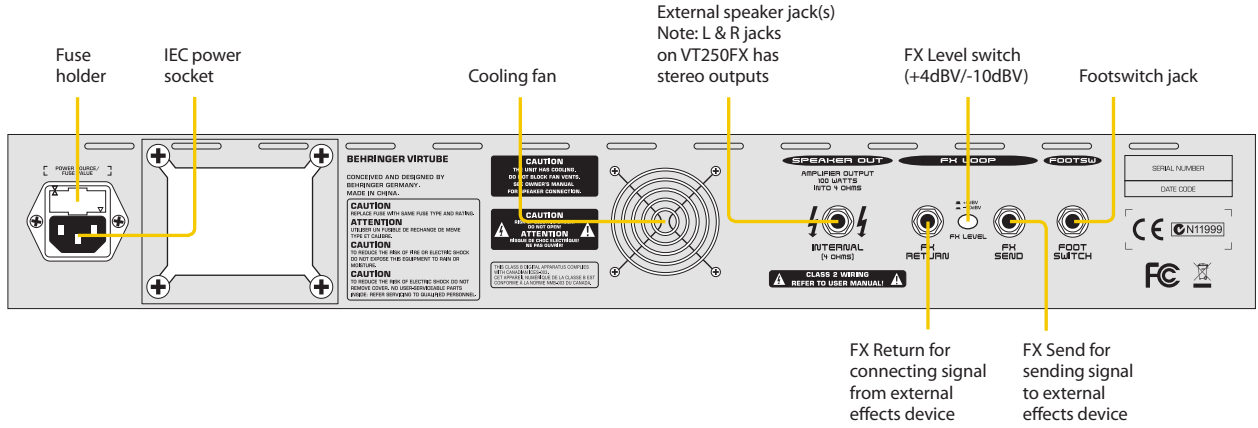

VIRTUBE

VT250FX/VT100FX

VT100FXH/VT50FX

VT30FX/VT15FX

VT15CD



Features	VT15CD	VT15FX	VT30FX	VT50FX	VT100FX	VT100FXH	VT250FX
Power	15W	15W	30W	60W	100W	100W	2 x 50W
Speaker(s)	1 x 8"	1 x 8"	1 x 10"	1 x 12"	1 x 12"	—	2 x 12"
Speaker jack(s)	—	—	—	1 x ¼"	1 x ¼"	2 x ¼"	2 x ¼"
Digital FX	—	✓	✓	✓	✓	✓	✓
FX Loop	—	—	—	✓	✓	✓	✓
FX Mix control	—	—	—	—	✓	✓	—
Phones jack	✓	✓	✓	✓	✓	✓	✓
Line Out	✓	✓	✓	✓	✓	✓	✓
CD In	✓	✓	✓	✓	✓	✓	✓
Mono/Stereo	Mono	Mono	Mono	Mono	Mono	Mono	Stereo
Middle control	—	—	—	✓	✓	✓	✓
Overdrive Middle Control	✓	✓	—	—	✓	✓	—
Separate Clean Middle Control	—	—	—	✓	✓	✓	✓
Contour control	—	—	✓	✓	✓	✓	✓
Crunch switch	—	—	—	—	✓	✓	—
OD1/OD2 switch	—	—	—	—	✓	✓	—
Footswitch	—	—	✓	✓	✓	✓	✓
Fan Cooling	—	—	—	✓	✓	✓	✓
Dimensions (H x W x D)	15.7 x 14.8 x 8.0" 400 x 375 x 205 mm	15.7 x 14.8 x 8.0" 400 x 375 x 205 mm	16.9 x 18.7 x 9.4" 430 x 475 x 240 mm	20.5 x 20.3 x 10.8" 520 x 515 x 275 mm	21.6 x 22.8 x 10.9" 550 x 580 x 275 mm	9.7 x 22.8 x 10.6" 245 x 580 x 270 mm	20.5 x 26.3 x 10.8" 520 x 670 x 275 mm
Weight	19.4 lbs (8.8 kg)	19.6 lbs (8.9 kg)	24.0 lbs (10.9 kg)	35.6 lbs (16.2 kg)	44 lbs (20 kg)	27.3 lbs (12.4kg)	48.4 lbs (22 kg)

For service, support or more information contact the BEHRINGER location nearest you:

Europe Tel.: +49 2154 9206 4149
Fax: +49 2154 9206 4199

USA/Canada Tel.: +1 425 672 0816
Fax: +1 425 673 7647

Singapore Tel.: +65 6845 1800
Fax: +65 6214 0275

Australia Tel.: +61 03 9877 7170
Fax: +61 03 9877 7870

Japan Tel.: +81 3 5281 1180
Fax: +81 3 5281 1181

©2011 Red Chip Company Ltd. Technical specifications and appearance subject to change without notice. The information contained herein is correct at the time of printing. All trademarks are the property of their respective owners. BEHRINGER accepts no liability for any loss which may be suffered by any person who relies either wholly or in part upon any description, photograph or statement contained herein. 985-10000-00362

behringer.com

