

[®]**MACKIE**

C300z TWO-WAY LOUDSPEAKER USER'S MANUAL

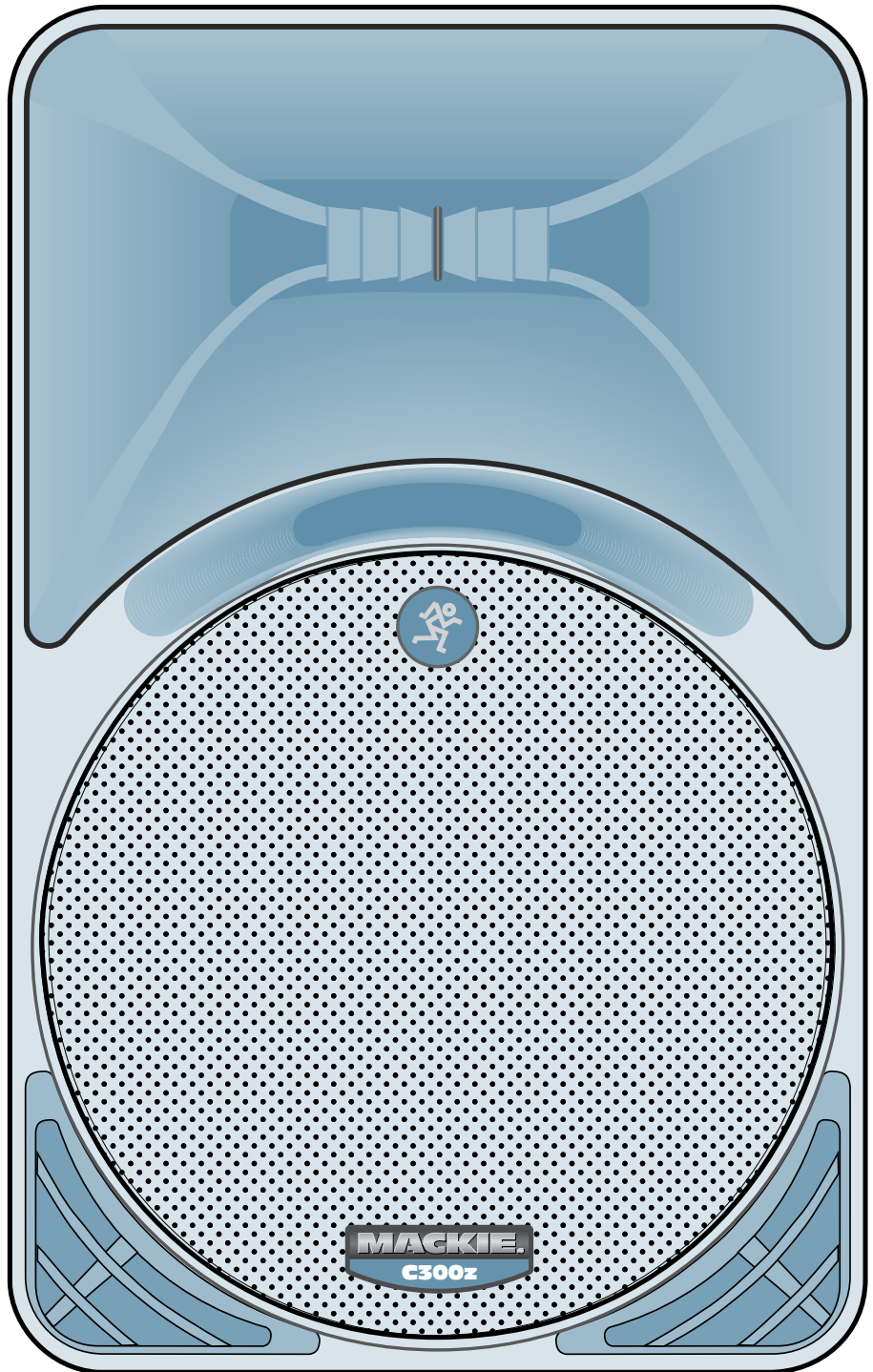

SAFETY INSTRUCTIONS

1. Read these instructions.
2. Keep these instructions.
3. Heed all warnings.
4. Follow all instructions.
5. Do not use this apparatus near water.
6. Clean only with a dry cloth.
7. Do not block any ventilation openings. Install in accordance with the manufacturer's instructions.
8. Do not install near any heat sources such as radiators, heat registers, stoves, or other apparatus (including amplifiers) that produce heat.
9. Only use attachments/accessories specified by the manufacturer.
10. Refer all servicing to qualified service personnel. Servicing is required when the apparatus has been damaged in any way, such as liquid has been spilled or objects have fallen into the apparatus, the apparatus has been exposed to rain or moisture, does not operate normally, or has been dropped.
11. The entire sound system must be designed in compliance with the current standards and laws regarding electrical systems.
12. When installing and using this apparatus, keep in mind the technical specifications indicated in the dedicated section of the manual.
13. Exposure to extremely high noise levels may cause permanent hearing loss. Individuals vary considerably in susceptibility to noise-induced hearing loss, but nearly everyone will lose some hearing if exposed to sufficiently intense noise for a period of time. The U.S. Government's Occupational Safety and Health Administration (OSHA) has specified the permissible noise level exposures shown in the following chart.



According to OSHA, any exposure in excess of these permissible limits could result in some hearing loss. To ensure against potentially dangerous exposure to high sound pressure levels, it is recommended that all persons exposed to equipment capable of producing high sound pressure levels use hearing protectors while the equipment is in operation. Ear plugs or protectors in the ear canals or over the ears must be worn when operating the equipment in order to prevent a permanent hearing loss if exposure is in excess of the limits set forth here.

<u>Duration Per Day In Hours</u>	<u>Sound Level dBA, Slow Response</u>	<u>Typical Example</u>
8	90	Duo in small club
6	92	
4	95	Subway Train
3	97	
2	100	Very loud classical music
1.5	102	
1	105	Tami screaming at Adrian about deadlines
0.5	110	
0.25 or less	115	Loudest parts at a rock concert

14. Rigging Precautions: When mounting or suspending Mackie loudspeaker enclosures, it is essential that load ratings, rigging techniques, and special safety considerations be appropriate for the installation. Use only the mounting/rigging points on the loudspeaker enclosure intended for this purpose. The user must determine the load requirements, dynamic loading, and any other contributing factors affecting the loudspeaker installation. The user must determine the proper safety factor for specific applications and the required load rating of the connection to structure. Comply with all applicable federal, state, and local regulations.

Mackie strongly recommends the following rigging system practices:

Documentation: Thoroughly document the mounting/rigging design with detailed drawings and parts lists.

Analysis: Have a licensed structural engineer or other qualified professional review and approve the mounting/rigging design before its implementation.

Installation: Use personnel experienced and qualified for mounting/rigging loudspeakers in accordance with and in compliance with all federal, state and local regulations.



DANGER: Loudspeakers should be mounted or suspended only by persons with knowledge of the proper hardware and rigging techniques. When stacking or pole-mounting loudspeakers, be sure that they are stabilized and secured from falling over or being accidentally pushed over. Failure to follow these precautions may result in damage to the equipment, personal injury, or death.

Contents

INTRODUCTION	3	SERVICE INFO	8
HOOKUP DIAGRAMS	4	Troubleshooting	8
Quick Start	4	Repair	8
PLACEMENT	6	CARE AND MAINTENANCE	9
PROTECTION	7	CONNECTIONS	9
RIGGING	7	C300z SPECIFICATIONS	10
		C300z LIMITED WARRANTY	11

Don't forget to visit our website at www.mackie.com for more information about this and other Mackie products.

INTRODUCTION

Thank you for choosing Mackie sound reinforcement loudspeakers.

The C300z is a portable two-way loudspeaker system, specifically designed to complement our PPM Series line of professional powered mixers. They are capable of extremely high sound pressure levels, and designed to give you the best performance of any loudspeaker in its class and price range.

The Transducers

The C300z features a 12-inch high-power low-frequency woofer and a 1.75-inch titanium diaphragm high-output compression driver. The woofer incorporates technology used in large-format touring systems and, with a massive, precision 3-inch voice coil, is virtually indestructible.

The high-frequency compression driver is mounted on a multi-cell aperture loaded on a constant directivity horn, providing an ultra-wide, controlled dispersion pattern and precise reproduction of the critical upper mid-range and high-frequencies. The result is an unbelievably smooth off-axis response that allows everyone in the audience to experience the same high-resolution audio no matter where they are seated.

Each driver has been specifically designed by our engineers for optimum performance in a lightweight high-strength cabinet.

The Crossover

This unique Low Impedance Compensated Crossover (LICC) design places inductors in series with the woofer whose values are markedly lower than conventional designs. This reduces the amount of energy that is typically wasted as heat and increases the amount of energy that is transformed into real acoustic power. It also incorporates dynamic protection for the compression driver from non-linear signals.

The Cabinet

The C300z cabinet was designed to be the strongest molded composite cabinet on the planet. This material is as strong as a rhinoceros horn, and rigid enough to prevent unwanted vibrations and standing waves in the cabinet. It has built-in fly points for hanging, and a socket in the bottom for mounting on a tripod stand. Although it is an exceptional choice for installed sound situations, its light weight and durable finish also make it ideal for portable sound system use. The asymmetrical trapezoidal design of the cabinet also makes it easy to use as a floor wedge for stage monitor applications.

The C300z offers a portable, lightweight solution for a variety of high-powered sound reinforcement applications.

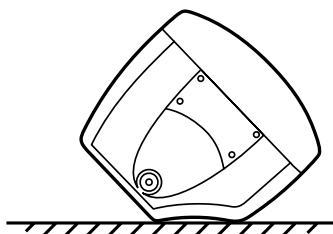

Please write your serial number here for future reference (i.e. insurance claims, tech support, return authorization, etc.):

Purchased at:

Date of purchase:



HOOKUP DIAGRAMS

Quick Start



Make all initial connections with the power switches OFF on all equipment. Make sure all master volume, level, or gain controls are all the way down.

1. Connect the line-level outputs from your mixing console (or other signal source) to the inputs of your power amplifier.
2. Connect the “Speaker Output” from your power amplifier (or powered mixer) to one of the INPUT connectors on the C300z, either the 1/4" TS jack or the NL4 Speakon™-style connector.
3. Turn on your mixing console (or other signal source).
4. Turn on the amplifier. Turn up its volume or gain control(s) as recommended by the manufacturer.
5. Start the signal source, whether it be speaking into a microphone or starting a CD player. Adjust the volume controls on the mixer (or other signal source) for normal operation.

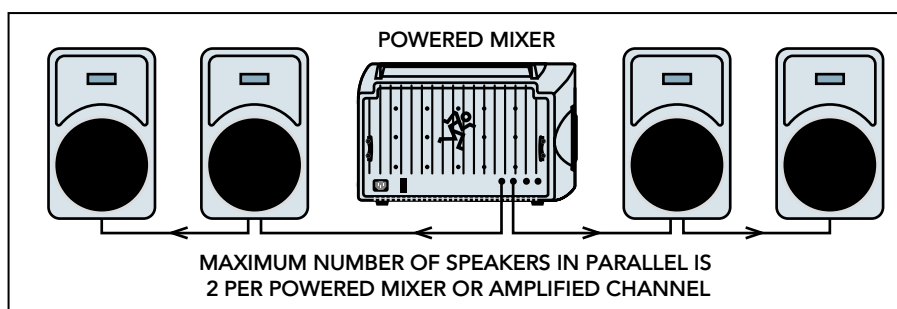

C300z: WITH A POWERED MIXER, AND USING THE THRU JACK

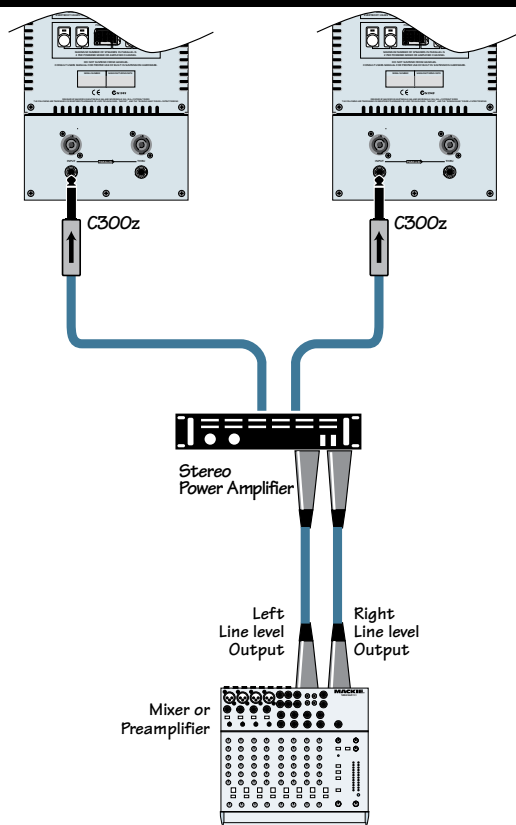

C300z: WITH A MIXER AND POWER AMPLIFIER

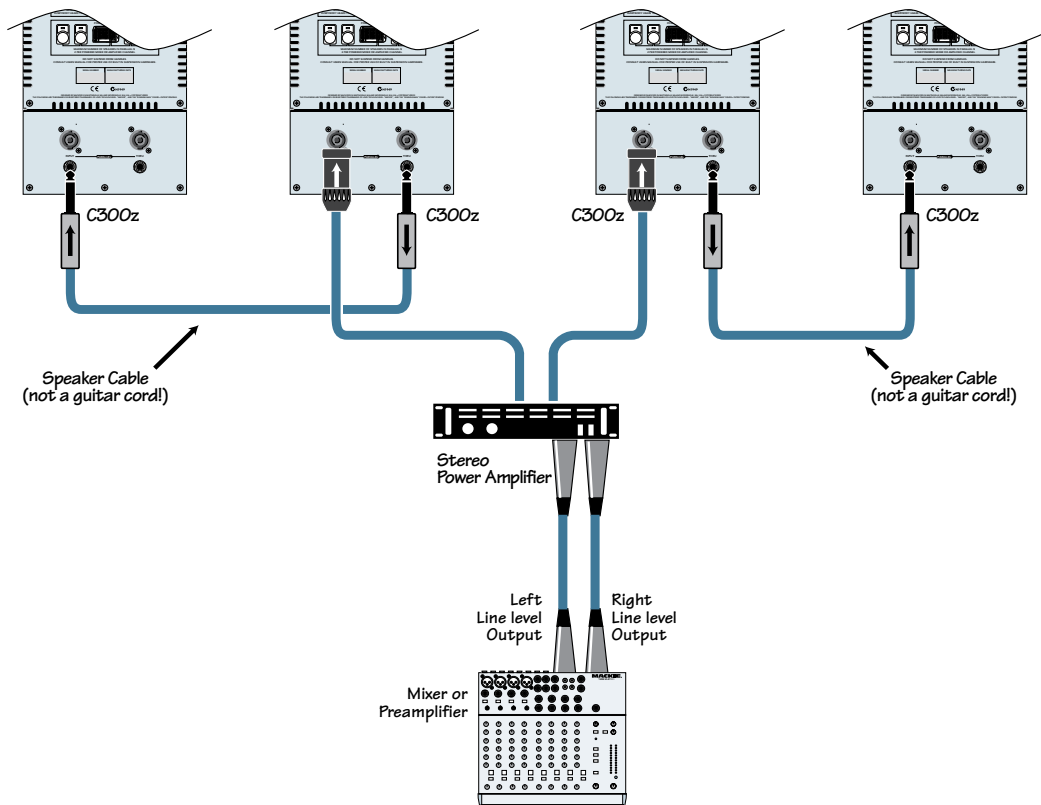

C300z: WITH A MIXER AND POWER AMPLIFIER, AND USING THE THRU JACK

The C300z can be used with a Mackie SWA1501 (or SWA1801) subwoofer to create an incredibly powerful system.

The active crossover inside the subwoofer splits the full-range stereo input signal into two ranges. The SWA1501 sums the left and right low-frequency range and plays it through its built-in amplifier and 15-inch woofer. It sends the stereo high-pass range to the C300zs, via an external power amplifier.

The C300z can be pole-mounted on top of the SWA1501 or 1801 as shown.

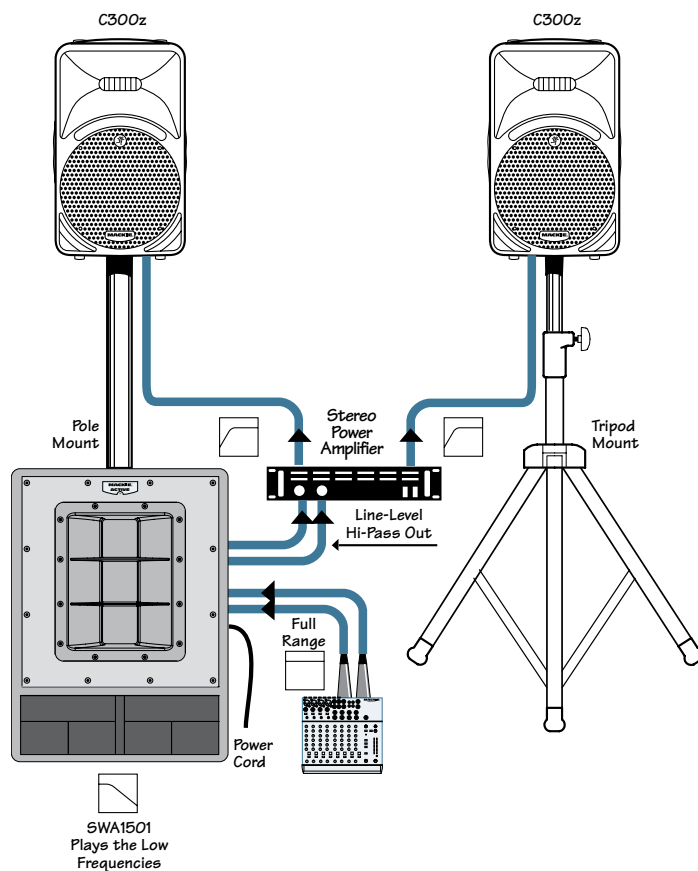

C300z: BIAMPING WITH A POWERED SUBWOOFER

PLACEMENT

The C300z loudspeakers are designed to sit on the floor, a tabletop, or to fit on a standard tripod speaker stand. They can also be suspended by the rigging points, shown at the right (also see "Rigging" on the next page).

You can lay the cabinet down on its side and use the C300z as a floor monitor. The asymmetrical trapezoidal shape of the cabinet provides a perfect angle for aiming up toward performers from the front of the stage.



Warning: Do not stack speakers in a column. This is to avoid the danger of toppling speakers.

As with any loudspeakers, protect them from moisture. If you are setting them up outdoors, make sure they are under cover if you expect rain.

Room Acoustics

The C300z loudspeakers are designed to sound as neutral as possible; that is, to reproduce the input signal as accurately as possible, *monitoring* the audio signal rather than changing it.

Room acoustics play a crucial role in the overall performance of a sound system. However, the wide high-frequency dispersion of the C300z helps to minimize the problems that typically arise.

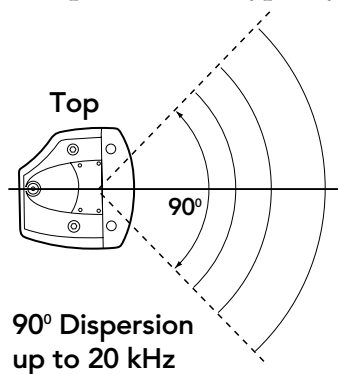

Here are some other placement tips:

- Avoid placing loudspeakers in the corners of a room. This increases the low frequency output and can cause the sound to be muddy and indistinct.
- Avoid placing loudspeakers against a wall. This, too, increases the low frequency output, though not as much as corner placement. However, if you do need to reinforce the low frequencies, this is a good way to do it.
- Avoid placing the speakers directly on a hollow stage floor. A hollow stage can resonate at certain frequencies, causing peaks and dips in the frequency response of the room. It's better to place the loudspeakers on a sturdy table or tripod stands.

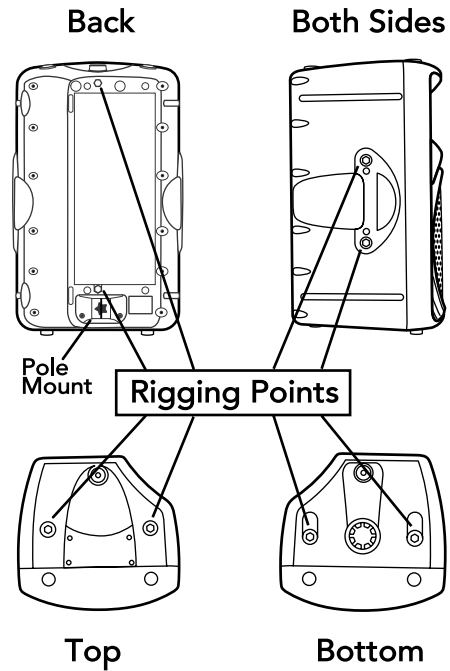

- Position the loudspeakers so the high-frequency drivers are 2 to 4 feet above ear level for the audience (make allowances for a standing/dancing-in-the-aisles audience). High frequencies are highly directional and tend to be absorbed much easier than lower frequencies. By providing direct line-of-sight from the loudspeakers to the audience, you increase the overall brightness and intelligibility of the sound system.
- Highly reverberant rooms, like many gymnasiums and auditoriums, are a nightmare for sound system intelligibility. Multiple reflections off the hard walls, ceiling, and floor play havoc with the sound. Depending on the situation, you may be able to take some steps to minimize the reflections, such as putting carpeting on the floors, closing draperies to cover large glass windows, or hanging tapestries or other materials on the walls to absorb some of the sound.

However, in most cases, these remedies are not possible or practical. So what do you do? Making the sound system louder generally doesn't work because the reflections become louder, too. The best approach is to provide as much direct sound coverage to the audience as possible. The farther away you are from the speaker, the more prominent will be the reflected sound.

Use more speakers strategically placed so they are closer to the back of the audience. If the distance between the front and back speakers is more than about 100 feet, you should use a delay processor to time-align the sound. (Since sound travels about 1 foot per millisecond, it takes about 1/10 of a second to travel 100 feet.)

PROTECTION

A protection circuit is built into the C300z to protect the high-frequency compression driver from excessive power. When the power to the HF driver approaches the maximum, the power delivered to the driver is momentarily reduced.



CAUTION: The protection circuit is designed to protect the HF driver under reasonable and sensible conditions. Should you choose to ignore the warning signs (i.e., frequent clip

LED indications, excessive distortion), you can still damage the speakers in the C300z by overdriving them past their recommended amplifier power-handling ratings, or past the point of amplifier clipping. Such damage is beyond the scope of the warranty.

Amplifier Power

We give you three power-handling numbers for the C300z: rms (continuous), music, and peak. So how much power do you really need to drive the C300z?

The answer to that question depends on what type of program material you are running through the system and how loud it needs to be.

Some audio signals have lots of momentary peaks whose amplitudes extend far above the average overall level of the program. Percussion instruments are a good example of this. Other types of signals, like highly compressed rock music, have a higher average signal level with fewer peaks. Speech reinforcement requires less power overall, but involves large moment-to-moment variations in level.

Assuming you want to use the full capability of the loudspeaker, and the program contains at least some momentary peaks, we recommend that you use an amplifier that is rated at twice the continuous power rating of the loudspeaker (into 8 ohms). For the C300z, this would be 300 watts x 2 = 600 watts per channel into 8 ohms. This insures that the amplifier can reproduce peaks that are 6 dB higher than the continuous (rms) power-handling rating before clipping occurs.

Preventing Loudspeaker Damage

Speaking of clipping, this is likely the number one cause of damage to loudspeakers. Clipping occurs when the signal at the output of any device in the system (not just the amplifier) reaches its maximum level. The input signal to the device may continue to increase, but the output simply

stops, and is characterized by a “flat-top” appearance to the waveform when viewed on an oscilloscope.

Normal Sine Wave Signal ☺

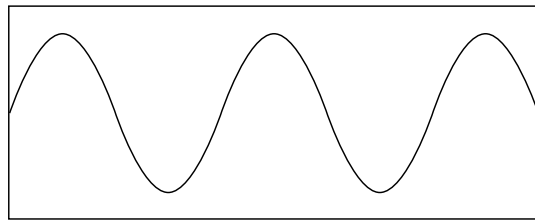

Clipped Sine Wave Signal ☹

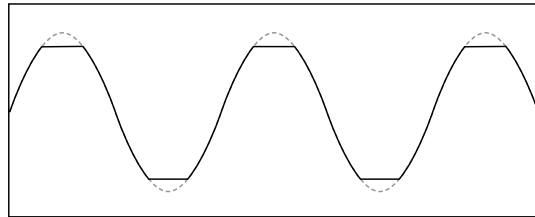

Clipping interrupts the motion of the transducer, creating distortion and excessive heat in the driver, which can damage it over time.

Some folks think that if they use a power amplifier whose power rating is below the maximum power-handling rating of the loudspeaker, then they can't possibly damage the loudspeaker. But if the amplifier is driven into clipping, even a lower power amplifier can damage the loudspeaker.

The bottom line is that to prevent damage to the loudspeakers, you must have a properly operating sound system. Proper operation of a sound system includes being aware of the types of audio signals being reproduced, controlling the output levels accordingly, and operating all the devices in the system so that no clipping occurs within the signal chain.

RIGGING

The C300z cabinets are fitted with ten rigging points as shown in the diagram on the previous page. These are M10 inserts. M10 threaded eyebolts (M10 x 1.5 mm x 20 mm) are available to fit in these inserts (PA-A1 Eyebolts).



WARNING: Never attempt to suspend the C300z loudspeakers by their handles. If you want to suspend them, use the rigging points only. Consult a professional rigger or structural

engineer prior to suspending loudspeakers from a structure not intended for that use. Always know the working load limit of the structure supporting the loudspeaker array. Always make sure that the rigging hardware minimum rating is at least five times the actual load.

SERVICE INFO

If you think your Mackie product has a problem, please check out the following troubleshooting tips and do your best to confirm the problem. Visit the Support section of our website (www.mackie.com/support) where you will find lots of useful information such as FAQs, documentation, and user forums. You may find the answer to the problem without having to send your Mackie product away.

Troubleshooting

No sound!

- Are the level controls on the mixer or amplifier turned all the way down? Follow the procedures in the “Quick Start” section on page 4 to verify that all the volume controls in the system are properly adjusted.
- Is the signal source working (and making union scale)? Make sure all the connecting cables are in good repair and securely connected at both ends.

One side is way louder than the other!

- Are the level controls set the same for both channels on the mixer and amplifier?
- Check the PAN control on the signal source. It may be turned too far to one side. If you’re using a stereo signal source, it may be delivering an out-of-balance stereo signal.
- Try swapping sides: Switch the speaker cables coming from the amplifier at the amplifier end. If the other side is louder now, the problem is with the amplifier, the mixer, or the signal source.

Poor bass performance

- Check the polarity of the connections between the amplifier and the loudspeakers. You may have your positive and negative connections reversed at one end of one cable.

It hurts when I touch my arm, or my leg, or even my head!

- You have a broken finger.

Bad sound!

- Is it loud and distorted? Follow the procedures described in the “Quick Start” section to verify that the levels are set properly.
- Are all the connections secure? It’s a good idea to periodically clean all electrical connections with a non-lubricating electrical contact cleaner.
- Keep practicing.

Repair

For warranty repair or replacement, refer to the warranty information on page 11.

Non-warranty repair for Mackie products is available at a factory-authorized service center. To locate your nearest service center, visit www.mackie.com, click “Support” and select “Locate a Service Center.” Service for Mackie products living outside the United States can be obtained through local dealers or distributors.

If you do not have access to our website, you can call our Tech Support department at 1-800-898-3211, Monday-Friday, 7 am to 5 pm Pacific Time, to explain the problem. Tech Support will tell you where the nearest factory-authorized service center is located in your area.

CARE AND MAINTENANCE

Your Mackie loudspeakers will provide many years of reliable service if you follow these simple guidelines:

- Avoid exposing the loudspeakers to moisture. If they are set up outdoors, be sure they are under cover if you expect rain.
- Avoid exposure to extreme cold (below freezing temperatures). If you must operate the loudspeakers in a cold environment, warm up the voice coils slowly by sending a low-level signal through them for about 15 minutes prior to high-power operation.
- Use a slightly damp cloth with a mild soap solution to clean the cabinets. Avoid getting moisture into any of the openings of the cabinet, particularly where the drivers are located.

CONNECTIONS

The C300z has 1/4" TS and Speakon™ style INPUT and THRU connectors. The connectors are wired in parallel, so use only one of the input connectors (either 1/4" TS or Speakon-style).

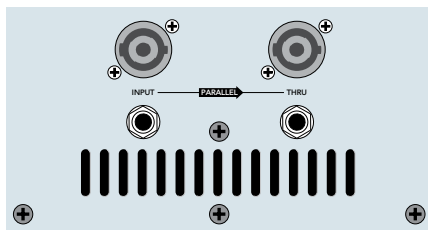

C300z Connector Panel

Normally, you would use only one THRU connector, but it is possible to use both THRU connectors. Keep in mind that all the speakers are connected in parallel through these connectors, so you want to be sure not to go below the minimum impedance requirement for your amplifier.

The C300z has a nominal impedance of 8 ohms.

Two C300zs in parallel equals 4 ohms.

Three C300zs in parallel equals 2.7 ohms.

Four C300zs in parallel equals 2 ohms.

Use heavy gauge, stranded wire for connecting a speaker to the output of a power amplifier.



Do not use coaxial cable like a guitar cord to make speaker connections. They are not designed to handle the high currents produced by a power amplifier and can overheat.

As the distance between the amplifier and speakers increases, the thickness of the wire should also increase. Speaker wire has resistance, and when electricity passes through a resistor, power is lost. The thicker the wire, the less the resistance it offers, and the more power actually gets to the speaker.

1/4" TS Phone Plugs and Jacks

"TS" stands for Tip-Sleeve, the two connections available on a mono 1/4" phone jack or plug. They are used for unbalanced signals and speaker connections.

1/4" TS Wiring:

Sleeve = Cold (-)

Tip = Hot (+)

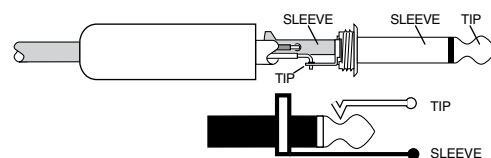

NL4-Type Plugs and Jacks

This connector is compatible with the popular Neutrik® Speakon® 4-pole plugs. These connectors are designed to handle the higher currents produced by amplifiers, and have a locking feature to prevent accidental disconnections. Simply line up the tabs on the plug with the jack on the C300z, push it in, and rotate it 1/4 turn to the right to lock it in place.

NL4 Wiring

Pin 1 - = Cold (-)

Pin 1 + = Hot (+)

Pin 2 - = No Connection

Pin 2 + = No Connection

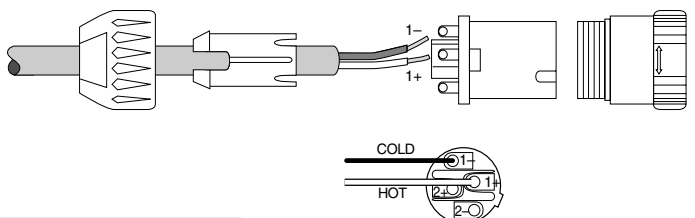

Need Help?
 You can reach a technical support representative
 Monday through Friday
 from 7 AM to 5 PM PST at:
1-800-898-3211
 After hours, visit www.mackie.com and click Support,
 or email us at: techmail@mackie.com

C300z SPECIFICATIONS

System Specifications

<i>Frequency Response (-3 dB)</i>	55 Hz – 18 kHz
<i>Frequency Range (-10 dB)</i>	45 Hz – 20 kHz
<i>Maximum SPL Long-term @ 1m</i>	123 dB
<i>Low-Frequency Crossover Type</i>	24 dB/octave, time offset corrected
<i>High-Frequency Crossover Type</i>	24 dB/octave
<i>Crossover Frequency</i>	1800 Hz

Audio

<i>Input Type:</i>	Speakon®-style NL4 jack 1/4-inch TS phone jack
<i>Input Impedance</i>	8 ohms
<i>Power Handling</i>	
rms:	300 watts
music:	500 watts
peak:	750 watts
<i>Operating Temperature Range</i>	-10°C to 45°C (14°F to 113°F)

Transducer Specifications

Low-Frequency Transducer

<i>Diameter</i>	12 in/300 mm
<i>Voice Coil Diameter</i>	3.0 in/75 mm
<i>Sensitivity (1W@1m)</i>	98 dB
<i>Nominal Impedance</i>	8 ohms
<i>Power Handling</i>	300 watts
<i>Frequency Range</i>	50 Hz – 3000 Hz

High-Frequency Driver and Horn

<i>Diaphragm Diameter</i>	1.75 in/44.5 mm
<i>Exit Throat Diameter</i>	1 in/24.5 mm
<i>Diaphragm Material</i>	Titanium
<i>Sensitivity (1W@1m)</i>	106 dB
<i>Nominal Impedance</i>	8 ohms
<i>Power Handling</i>	150 watts
<i>Frequency Range</i>	1000 Hz – 20000 Hz
<i>Horn Type</i>	Composite: Exponential and Conical
<i>Mouth Size</i>	12 in/305 mm W x 7 in/178 mm H
<i>Horizontal Coverage</i>	90° ± 10° (1 kHz – 20 kHz)
<i>Vertical Coverage</i>	45° ± 10° (2.8 kHz – 20 kHz)

Safety Features

<i>Over-Excursion Protection</i>	Second-Order High-Pass Filter
<i>Driver Protection</i>	Dynamic protection for compression driver

Construction Features

<i>Basic Design</i>	Asymmetrical Trapezoidal
<i>Enclosure Alignment</i>	Sixth-Order
<i>Material</i>	Polypropylene
<i>Finish</i>	Grey, textured finish
<i>Handles</i>	One on each side, one on top
<i>Mounting Methods</i>	Integrated mounting points, M10 Two located on each side, top, bottom, and rear of enclosure
<i>Grille</i>	Perforated metal with weather-resistant coating

Physical Properties

<i>Height</i>	26 in/660 mm
<i>Width</i>	15.4 in/390 mm
<i>Depth</i>	14.8 in/376 mm
<i>Weight</i>	43 lbs/19.5 kg

Options

PA-A1 forged shoulder eyebolt hardware (M10 x 1.5 mm x 20 mm)
--

Disclaimer

Since we are always striving to make our products better by incorporating new and improved materials, components, and manufacturing methods, we reserve the right to change these specifications at any time without notice.

“Mackie” and the “Running Man” figure are registered trademarks of LOUD Technologies Inc.

All other brand names mentioned are trademarks or registered trademarks of their respective holders, and are hereby acknowledged.

©2004-2008 LOUD Technologies Inc.
All Rights Reserved.



Please keep your sales receipt in a safe place.

A. LOUD Technologies Inc. warrants all materials, workmanship and proper operation of this product for a period of **one year** from the original date of purchase. You may purchase an additional 24-month Extended Warranty (for a total of 36 months of coverage). Visit our website and follow the "Product Registration" links for details (www.mackie.com). If any defects are found in the materials or workmanship or if the product fails to function properly during the applicable warranty period, LOUD Technologies, at its option, will repair or replace the product. **This warranty applies only to equipment sold and delivered within the U.S. and Canada by LOUD Technologies Inc. or its authorized dealers.**

B. For faster processing (not to mention a free gift), register online or mail in the product registration card.

C. Unauthorized service, repairs, or modification of Mackie products will void this warranty. To obtain repairs or replacement under warranty, you must have a copy of your sales receipt from the authorized Mackie dealer where you purchased the product. It is necessary to establish purchase date and determine whether your Mackie product is within the warranty period.

D. To obtain warranty repair or replacement:

1. Call Mackie Technical Support at 800/898-3211, 7 AM to 5 PM Monday through Friday (Pacific Time) to get authorization for repair or replacement. Alternately, go to the Mackie website, click "Support" (www.mackie.com/support), and follow the instructions for reporting a warranty issue and submitting a request for an advance replacement.

2. **Advance Replacement:** Mackie will ship a replacement unit to you along with an invoice for the suggested retail price of the replacement unit. You must return the defective unit immediately to cancel the invoice. If you do not return the defective unit within 30 days, you must pay the full amount stated in the invoice to satisfy your debt.

3. **Repair:** When you call Mackie Technical Support, explain the problem and obtain a Service Request Number. Have your Mackie product's serial number ready. **You must have a Service Request Number before you can obtain factory-authorized service.**

- Pack the product in its original shipping carton. Also include a note explaining exactly how to duplicate the problem, a copy of the sales receipt with price and date showing, your daytime phone number and return street address (no P.O. boxes or route numbers, please!), and the Service Request Number. If we cannot duplicate the problem or establish the starting date of your Limited Warranty, we may, at our option, charge for service time and parts.

- Ship the product in its original shipping carton, **freight prepaid** to the authorized service center. Write the Service Request Number in **BIG PRINT** on top of the box. The address of your closest authorized service center will be given to you by Technical Support, or it may be obtained from our website. Once it's repaired, the authorized service center will ship it back by ground shipping, pre-paid (if it qualified as a warranty repair).

Note: Under the terms of the warranty, you must ship or drop-off the unit to an authorized service center. The return ground shipment is covered for those units deemed by us to be under warranty.

Note: You must have a sales receipt from an authorized Mackie dealer for your unit to be considered for warranty repair.

IMPORTANT: Make sure that the Service Request Number is plainly written on the shipping carton. No receipt, no warranty service.

E. LOUD Technologies reserves the right to inspect any products that may be the subject of any warranty claims before repair or replacement is carried out. LOUD Technologies may, at our option, require proof of the original date of purchase in the form of a dated copy of the original dealer's invoice or sales receipt. Final determination of warranty coverage lies solely with LOUD Technologies.

F. Any products returned to one of the LOUD Technologies factory-authorized service centers, and deemed eligible for repair or replacement under the terms of this warranty will be repaired or replaced. LOUD Technologies and its authorized service centers may use refurbished parts for repair or replacement of any product. Products returned to LOUD Technologies that do not meet the terms of this Warranty will not be repaired unless payment is received for labor, materials, return freight, and insurance. Products repaired under warranty will be returned freight prepaid by LOUD Technologies to any location within the boundaries of the USA or Canada.

G. LOUD Technologies warrants all repairs performed for 90 days or for the remainder of the warranty period. This warranty does not extend to damage resulting from improper installation, misuse, neglect or abuse, or to exterior appearance. This warranty is recognized only if the inspection seals and serial number on the unit have not been defaced or removed.

H. LOUD Technologies assumes no responsibility for the timeliness of repairs performed by an authorized service center.

I. This warranty is extended to the original purchaser. This warranty may be transferred to anyone who may subsequently purchase this product within the applicable warranty period for a nominal fee. A copy of the original sales receipt is required to obtain warranty repairs or replacement.

J. This is your sole warranty. LOUD Technologies does not authorize any third party, including any dealer or sales representative, to assume any liability on behalf of LOUD Technologies or to make any warranty for LOUD Technologies Inc.

K. THE WARRANTY GIVEN ON THIS PAGE IS THE SOLE WARRANTY GIVEN BY LOUD TECHNOLOGIES INC. AND IS IN LIEU OF ALL OTHER WARRANTIES, EXPRESS AND IMPLIED, INCLUDING THE WARRANTIES OF MERCHANTABILITY AND FITNESS FOR A PARTICULAR PURPOSE. THE WARRANTY GIVEN ON THIS PAGE SHALL BE STRICTLY LIMITED IN DURATION TO ONE YEAR FROM THE DATE OF ORIGINAL PURCHASE FROM AN AUTHORIZED MACKIE DEALER. UPON EXPIRATION OF THE APPLICABLE WARRANTY PERIOD, LOUD TECHNOLOGIES INC. SHALL HAVE NO FURTHER WARRANTY OBLIGATION OF ANY KIND. LOUD TECHNOLOGIES INC. SHALL NOT BE LIABLE FOR ANY INCIDENTAL, SPECIAL, OR CONSEQUENTIAL DAMAGES THAT MAY RESULT FROM ANY DEFECT IN THE MACKIE PRODUCT OR ANY WARRANTY CLAIM. Some states do not allow exclusion or limitation of incidental, special, or consequential damages or a limitation on how long warranties last, so some of the above limitations and exclusions may not apply to you. This warranty provides specific legal rights and you may have other rights which vary from state to state.

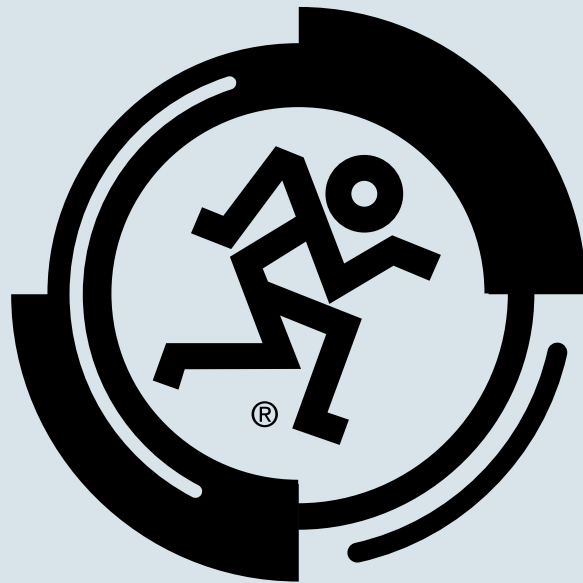

MACKIE.®

16220 Wood-Red Road NE • Woodinville, WA 98072 • USA

US and Canada: 800.898.3211

Europe, Asia, Central and South America: 425.487.4333

Middle East and Africa: 31.20.654.4000

Fax: 425.487.4337 • www.mackie.com

E-mail: sales@mackie.com