

Onyx Blackbird

The Mackie Onyx Blackbird Premium 16x16 FireWire Recording Interface delivers industry-leading recording quality via eight boutique Onyx preamps and high-end 24-bit/96 kHz conversion in a sleek, rackmount design.

Blackbird is equipped with high-end Cirrus Logic® AD/DA converters offering 114 dB dynamic range (A-weighted), phantom power and built-in DIs on the two front panel “Super Channels”.

The “Super Channels” also provide quick access to crucial recording tools and feature true analog hardware monitoring, in both mono and stereo, for hassle-free zero-latency recording.

The additional mic inputs, onboard 8x8 ADAT and word clock I/O provide easy integration into any digital or analog setup. Blackbird also works as a standalone 8-channel preamp rack.

For more complex sessions, the powerful 18x16 Blackbird Control DSP Matrix Mixer allows for quick mix creation and routing of any input to any output at any volume and pan orientation. Additionally, custom names may be applied to all channels and output mixes for quick, at-a-glance reference and control.

Blackbird is Mac/PC friendly and ready for most major DAWs right out of the box. No DAW? No problem. Blackbird comes standard with Mackie’s Traktion 3™ Music Production Software so you can get started recording right away.

Onyx Blackbird features a “Built-Like-A-Tank” design, with a sleek, powder-coated all-metal chassis.

APPLICATIONS

Multitrack studio and field recording, video post-production, multimedia applications, broadcast, and many, many more.



FEATURES:

- Eight boutique-quality Onyx mic preamps with class-leading fidelity and dynamic range
- High-headroom design with ultra-low noise and distortion
- Professional 16x16 24-bit/96 kHz recording/playback
 - Flexible FireWire routing
 - 8x8 ADAT I/O for ultimate expandability
 - Onboard wordclock I/O for studio and live integration
 - Acclaimed JetPLL™ jitter elimination technology
- High-end Cirrus Logic® AD/DA converters with 114 dB dynamic range (A-weighted)
- Compatible with most major DAWs
 - Pro Tools® 9
 - Logic®
 - SONAR™
 - Cubase®
 - Ableton® Live
 - Final Cut Pro®
 - ...and more
- Powerful and flexible “Super Channels”
 - Front panel connectivity for easy access
 - True analog hardware monitoring of inputs, in mono or stereo, for easy zero-latency recording
 - 80 Hz low-cut switches
 - Dedicated 48V phantom power
 - Built-in DI for direct connection of guitars, bass, etc.
 - Inserts for outboard processing gear
- Ideal eight input standalone preamp unit with up to 96 kHz ADAT (S/MUX II) outputs
- 48V phantom power on all inputs for use with condenser microphones
- Studio monitor, main and alternative outputs with independent level control and source selection
- Two headphone outputs with independent level control and source selection
- Includes powerful Blackbird Control DSP Matrix Mixer
 - Route any input to any output
 - Zero-latency tracking of all inputs
 - Quickly set up independent mixes for headphones and more
- Easily aggregate up to four units on Mac or PC
- “Built-Like-A-Tank” sleek and ergonomic chassis design
- Includes Traktion 3™ Music Production Software for Mac or PC

BLACKBIRD SPECIFICATIONS

Noise Characteristics

Equivalent Input Noise (EIN), mic input at insert, 150 Ω source impedance, 20 Hz to 20 kHz:	
60 dB (max) gain:	-127.0 dBu
40 dB gain:	-126.5 dBu
Equivalent Input Noise (EIN), mic input at insert, 50 Ω source impedance, A-weighted:	
60 dB (max) gain:	-130.5 dBu
40 dB gain:	-130.0 dBu
Output Noise Figure (1/4" Main Out, Alt Out, or Mon Out with Mon level at unity gain):	
-91.0 dBu (95.0 dB SNR, ref +4 dBu), A-weighted	
FireWire Through (Record + Playback) Dynamic Range:	
111.5 dB, ref +22 dBu max output level, A-weighted	

Frequency Response

Mic to insert:	
<10 Hz to 150 kHz	+0 dB / -1 dB
Mic to Monitor or Main Outs (direct monitor analog-only path), unity gain for XLR input:	
<10 Hz to 80 kHz	+0 dB / -1 dB
Line to Monitor or Main Outs (direct monitor analog-only path), unity gain for 1/4" TRS input (+20 dB on mic preamp):	
<10 Hz to 22 kHz	+0 dB / -1 dB
FireWire Through, mic input to any output, unity gain:	
44.1 kHz sample rate:	
± 0.5 dB, 20 Hz to 20 kHz, -3 dB at 21 kHz	
96 kHz sample rate:	
± 0.5 dB, 20 Hz to 20 kHz, -3 dB at 45 kHz	

Distortion (THD+N)

Mic to insert, 20 Hz to 20 kHz, 20 Hz to 80 kHz bandwidth:	
+4 dBu in, unity gain, +4 dBu out:	0.001%
Line to insert, 20 Hz to 20 kHz, 20 Hz to 80 kHz bandwidth:	
+4 dBu in, unity gain (+20 dB on mic preamp), +4 dBu out:	0.0015%
Hi-Z to monitor (direct monitor analog path, stereo), 1 kHz, 22 Hz to 22 kHz bandwidth:	
+0 dBu in, unity gain, +0 dBu out:	<0.004%
FireWire Through, +4 dBu mic input, to Blackbird Control, routed to Main Output, all gain stages unity, 20 Hz to 20 kHz:	
All inputs muted except active channel:	0.004%
No analog inputs muted:	0.006%

Attenuation and Crosstalk

1 kHz relative to +0 dBu, 20 Hz to 20 kHz bandwidth, unweighted:	
Main Out, Direct Monitor (TO MON) knob at min: -87 dBu	
Monitor Out, Direct Monitor (TO MON) knob at min, Monitor knob at min: -108 dBu	
Monitor Out, Direct Monitor (TO MON) knob at max, Monitor knob at min: -82 dBu	

Common Mode Rejection Ratio (CMRR)

Mic input to Insert, max gain, 150 Ω termination 1 kHz:	> -70 dB
---	----------

Maximum Levels

Mic input, gain at min (0 dB):	+22 dBu
Mic input, gain at max (60 dB):	-38 dBu
Line input, gain at -20 dB:	+22 dBu
Instrument input, gain at -20 dB:	+22 dBu
All Outputs:	+22 dBu

FireWire

Sample rates available:	44.1 kHz, 48 kHz, 88.2 kHz, 96 kHz
Buffer Size:	64 (44.1 kHz and 48 kHz only), 128, 256, 512, 1024, 2048, 3072
Resolution:	24-bit
ADC: Cirrus CS5368	
114 dB typical, 24-bit, A-weighted, 10 Hz to 20 kHz BW	
0.0006% typical, 0.0011% maximum THD+N, 24-bit, -1 dBFS, 10 Hz to 20 kHz BW	
DAC: Cirrus CS4385	
114 dB typical, 24-bit, A-weighted, 10 Hz to 20 kHz BW	
0.001% typical, 0.002% maximum THD+N, 24-bit, 0 dBFS, 10 Hz to 20 kHz BW	

Meters

Bi-color channel meters:	
Red overload, +18 dBu	
Green signal present, -20 dBu	

Input and Output Impedance

Mic input:	2.8 k Ω balanced
Line input:	30 k Ω balanced 15 k Ω unbalanced
Hi-Z input:	1 M Ω unbalanced
Phones output:	25 Ω
Channel inserts:	150 Ω
All other outputs:	300 Ω

BLACKBIRD SPECIFICATIONS CONTINUED...**AC Power Requirements**

Power Consumption:	25 watts
Universal AC Power Supply:	100 VAC – 240 VAC, 50 – 60 Hz
Operating Temperature	0° - 40°C 32° - 104°F

Physical Properties (packaged product)

Height	4.0 in / 102 mm
Depth	14.0 in / 356 mm
Width	20.6 in / 523 mm
Weight	10.2 lb / 4.6 kg

Physical Properties (product)

Height	1.8 in / 46 mm
Depth	10.2 in / 260 mm
Width	19.0 in / 483 mm
Weight	8.2 lb / 3.7 kg

Ordering Information

Blackbird 16X16 Firewire Recording Interface, US	P/N 2034520-00
Blackbird 16X16 Firewire Recording Interface, EU	P/N 2034520-01

BLACKBIRD DIMENSIONS

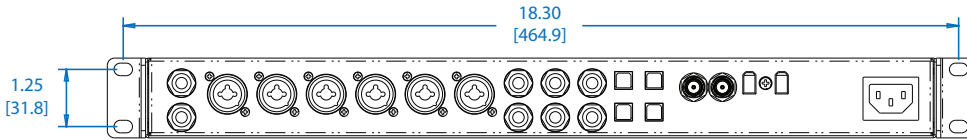

NOTES:

1. WEIGHT APPROX. 8.2 lb [3.7 kg].
2. SHIPPING WEIGHT APPROX. 10.2 lb [4.6 kg].

UNLESS OTHERWISE SPECIFIED: ALL DIMENSIONS ARE IN INCHES DUAL [MM] DIMENSIONS FOR REF ONLY

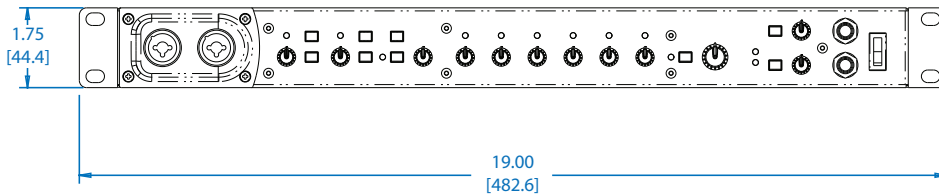
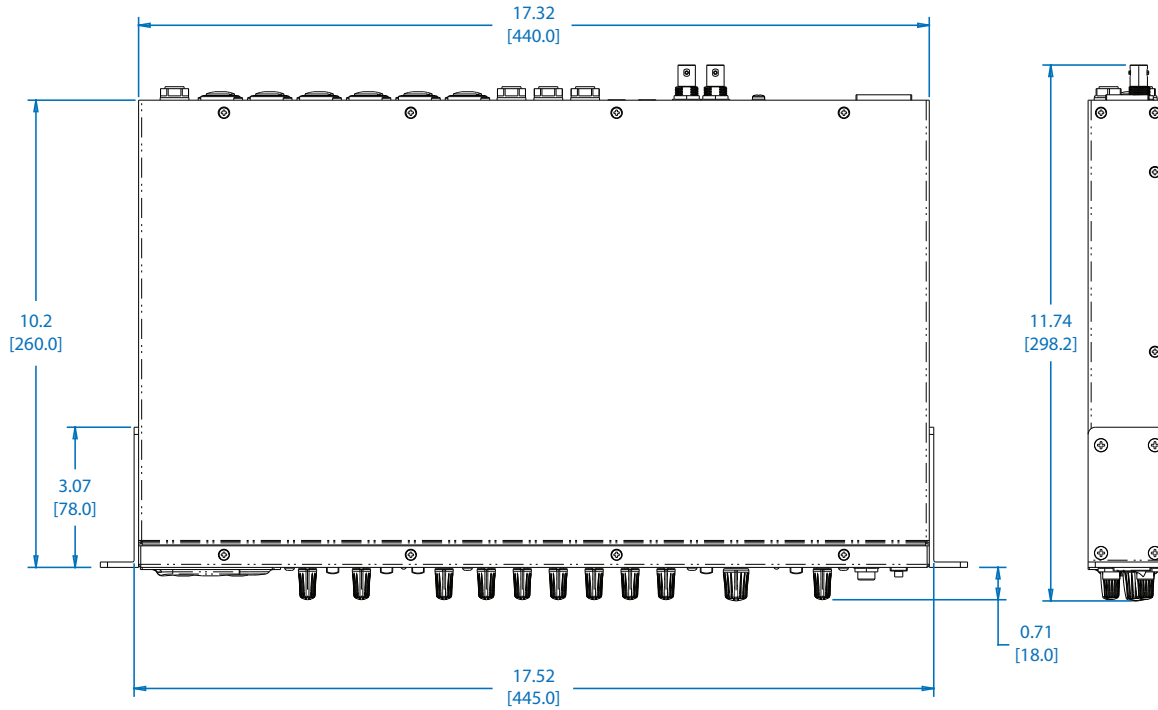

BLACKBIRD BLOCK DIAGRAM

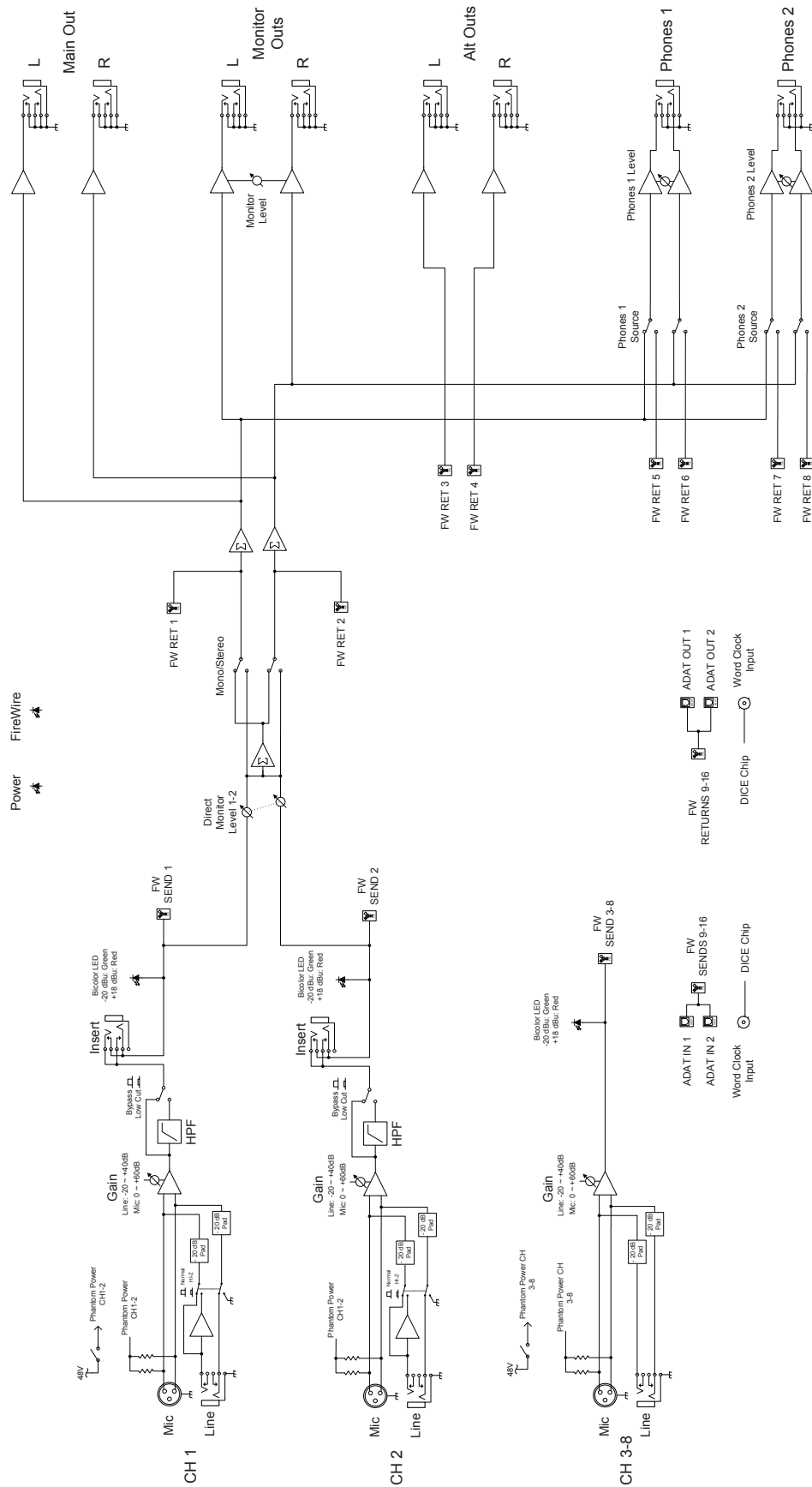

Note: Latching switches are shown in their UP states

BLACKBIRD FRONT AND REAR PANELS

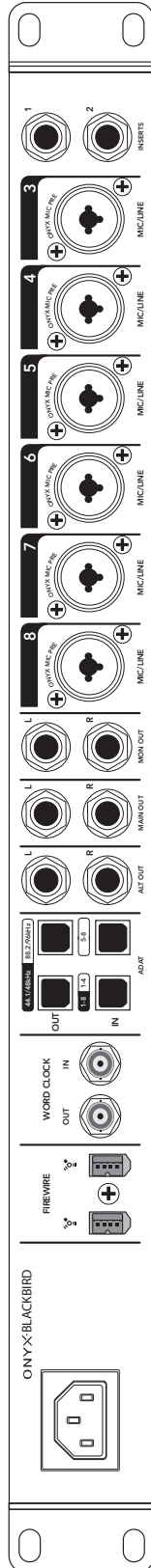
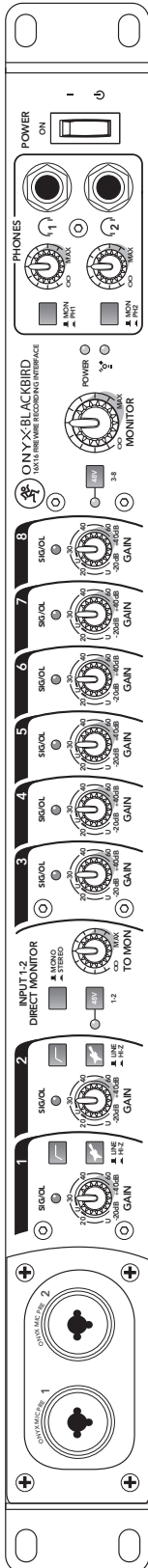

Electronic files for this product are available at:
www.mackie.com

Specification Sheet

Blackbird_SS.PDF

Owner's Manual

Blackbird_OM.PDF

Since we are always striving to make our products better by incorporating new and improved materials, components, and manufacturing methods, we reserve the right to change these specifications at any time without notice. "Mackie" and the "Running Man" figure are registered trademarks of LOUD Technologies Inc. All other brand names mentioned are trademarks or registered trademarks of their respective holders, and are hereby acknowledged.

©2011 LOUD Technologies Inc. All Rights Reserved.

MACKIE®

www.mackie.com

16220 Wood-Red Road NE

Woodinville, WA 98072 USA

800-898-3211, Fax 425-487-4337, sales@mackie.com

Part No. SW0883 Rev. A 06/11