

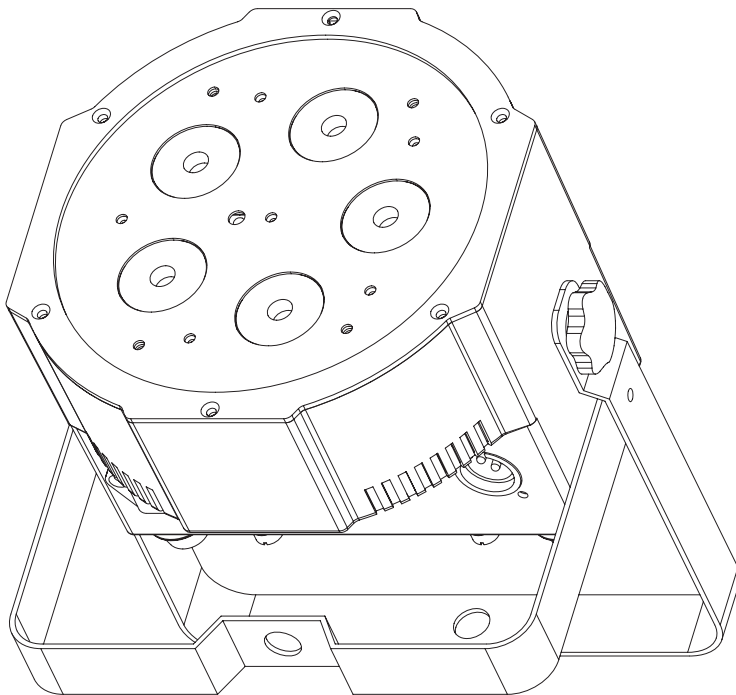

# MEGA QA GO



## *User Instructions*

©2016 ADJ Products, LLC all rights reserved. Information, specifications, diagrams, images, and instructions herein are subject to change without notice. ADJ Products, LLC logo and identifying product names and numbers herein are trademarks of ADJ Products, LLC. Copyright protection claimed includes all forms and matters of copyrightable materials and information now allowed by statutory or judicial law or hereinafter granted. Product names used in this document may be trademarks or registered trademarks of their respective companies and are hereby acknowledged. All non-ADJ Products, LLC brands and product names are trademarks or registered trademarks of their respective companies.

**ADJ Products, LLC** and all affiliated companies hereby disclaim any and all liabilities for property, equipment, building, and electrical damages, injuries to any persons, and direct or indirect economic loss associated with the use or reliance of any information contained within this document, and/or as a result of the improper, unsafe, insufficient and negligent assembly, installation, rigging, and operation of this product.

Europe Energy Saving Notice

Energy Saving Matters (EuP 2009/125/EC)

Saving electric energy is a key to help protecting the environment. Please turn off all electrical products when they are not in use. To avoid power consumption in idle mode, disconnect all electrical equipment from power when not in use. Thank you!

## Mega QA Go

## Introduction

**Unpacking:** Thank you for purchasing the Mega QA Go by ADJ Products, LLC. Every Mega QA Go has been thoroughly tested and has been shipped in perfect operating condition. Carefully check the shipping carton for damage that may have occurred during shipping. If the carton appears to be damaged, carefully inspect your fixture for any damage and be sure all accessories necessary to operate the unit has arrived intact. In the case damage has been found or parts are missing, please contact our toll free customer support number for further instructions. Do not return this unit to your dealer without first contacting customer support.

**Introduction:** The ADJ Mega QA Go is a DMX intelligent, high powered LED par fixture. This fixture can be used in a stand alone mode or connected in a Master/Slave configuration. This wash has five operating modes: Sound Active mode, Auto Run mode, RGBA Dimmer mode, Static Color mode, and DMX control mode. To optimize the performance of this product, please read these operating instructions carefully to familiarize yourself with the basic operations of this unit. These instructions contain important safety information regarding the use and maintenance of this unit. Please keep this manual with the unit, for future reference.

**Customer Support:** ADJ Products, LLC provides a customer support line, to provide set up help and to answer any question should you encounter problems during your set up or initial operation. You may also visit us on the web at [www.adj.com](http://www.adj.com) for any comments or suggestions. Service Hours are Monday through Friday 8:00 a.m. to 4:30 p.m. Pacific Standard Time.

Voice: (323) 582-3322

Fax: (323) 582-3108

E-mail: [support@AmericanDJ.com](mailto:support@AmericanDJ.com)

**Warning!** To prevent or reduce the risk of electrical shock or fire, do not expose this unit to rain or moisture.

**Caution!** There are no user serviceable parts inside this unit. Do not attempt any repairs yourself, doing so will void your manufactures warranty. In the unlikely event your unit may require service please contact ADJ Products, LLC.

**PLEASE recycle the shipping carton when ever possible.**

## Mega QA Go

## Features

- Five Operating Modes
- Electronic Dimming 0-100%
- 5 Selectable Dimming Curves
- 64 Color Macros
- Built in Microphone
- DMX-512 protocol
- 3-Pin DMX Connection
- 8 DMX Modes: 1 Channel Mode, 2 Channel Mode, 3 Channel Mode, 4 Channel Mode, 5 Channel Mode, 6 Channel Mode, 7 Channel Mode, & 8 Channel Mode.
- ADJ UC IR, (Not Included) & Airstream IR compatible
- Power Cord Daisy Chain (See page 26)

## Mega QA Go

## Warranty Registration

The Mega QA Go carries a 2 year limited warranty. Please fill out the enclosed warranty card to validate your purchase. All returned service items whether under warranty or not, must be freight pre-paid and accompany a return authorization (R.A.) number. The R.A. number must be clearly written on the outside of the return package. A brief description of the problem as well as the R.A. number must also be written down on a piece of paper included in the shipping carton. If the unit is under warranty, you must provide a copy of your proof of purchase invoice. You may obtain a R.A. number by contacting our customer support team on our customer support number. All packages returned to the service department not displaying a R.A. number on the outside of the package will be returned to the shipper.

## Mega QA Go

## Installation

The unit should be mounted using a mounting clamp (not provided), affixing it to the mounting bracket that is provided with the unit. Always ensure that the unit is firmly fixed to avoid vibration and slipping while operating. Always ensure that the structure to which you are attaching the unit is secure and is able to support a weight of 10 times the unit's weight. Also, always use a safety cable that can hold 12 times the weight of the unit when installing the fixture. The equipment must be installed by a professional, and it must be installed in a place where it is out of the reach of people's grasp.

- To reduce the risk of electrical shock or fire, do not expose this unit rain or moisture
- Do not spill water or other liquids into or on to your unit.
- Do not attempt to operate this unit if the power cord has been frayed or broken. Do not attempt to remove or break off the ground prong from the electrical cord. This prong is used to reduce the risk of electrical shock and fire in case of an internal short.
- Disconnect from main power before making any type of connection.
- Do not remove the cover under any conditions. There are no user serviceable parts inside.
- Never operate this unit when it's cover is removed.
- Never plug this unit in to a dimmer pack
- Always be sure to mount this unit in an area that will allow proper ventilation. Allow about 6" (15cm) between this device and a wall.
- Do not attempt to operate this unit, if it becomes damaged.
- This unit is intended for indoor use only, use of this product out doors voids all warranties.
- During long periods of non-use, disconnect the unit's main power.
- Always mount this unit in safe and stable matter.
- Power-supply cords should be routed so that they are not likely to be walked on or pinched by items placed upon or against them, paying particular attention to the point they exit from the unit.
- Cleaning -The fixture should be cleaned only as recommended by the manufacturer. See page 31 for cleaning details.
- Heat -The appliance should be situated away from heat sources such as radiators, heat registers, stoves, or other appliances (including amplifiers) that produce heat.
- The fixture should be serviced by qualified service personnel when:
  - A. The power-supply cord or the plug has been damaged.
  - B. Objects have fallen, or liquid has been spilled into the appliance.
  - C. The appliance has been exposed to rain or water.
  - D. The appliance does not appear to operate normally or exhibits a marked change in performance.

## 1. Handling of Batteries

### 1.1 Do Not Short Circuit the Battery

Try to never short circuit the battery. It generates a very high current which could cause the battery to overheat which may result in electrolyte gel leakage, harmful fumes, or explosion. The LIR tabs may easily short-circuit by placing them on conductive surface. A short circuit may lead to heat build up and damage of the battery. An appropriate circuitry with PCM is employed to protect accidental short circuit of the battery pack.

### 1.2 Mechanical shock

Dropping the unit, impact hit, bending, etc. may cause failure or shortend life of the LIR battery.

## 3. Other

### 3.1 Battery connection

- 1). Direct soldering of wire leads or devices to the battery is strictly prohibited.
- 2). Lead tabs with pre-soldered wiring shall be spot welded to the batteries. Direct soldering may cause damage of components, such as separator and insulator, by heat build up.

### 3.2 Prevention of short circuit within a battery pack

There is enough insulation layers between wiring and the batteries to provide extra safety protection. The battery pack is constructed in a way that no short circuit will occur which may cause smoke or fire.

### 3.3 Do No Disassemble the Batteries

- 1). Never disassemble the batteries.  
Doing this may cause a internal short circuit in the battery, which may lead to harmful fumes, fire, explosion, or other problems.
- 2). Electrolyte Gel is harmful  
Electrolyte Gel should not leak from the LIR battery. Should the electrolyte gel come into contact with the skin or eyes, flush the

area of contact immediately with fresh water and seek medical attention immediately.

### **3.4 Do Not Expose the Battery to Heat or Fire**

Never incinerate or dispose of the batteries in fire. This may cause an explosion, which would be very dangerous.

### **3.5 Do Not Expose the Battery to water or liquids**

Never soak/drop the batteries in liquids such as water, seawater, drinks such as soft drinks, juices, coffee or other.

### **3.6 Battery Replacement**

For battery replacement please contact American DJ customer support (800) 322-6337.

### **3.7 Do Not use a damaged Battery**

The battery could be damaged during shipping, caused by shock. Should the battery be found damaged, including damages to the plastic casing of the battery, deformation of the battery package, smelling of an electrolyte, or leakage of the electrolyte gel, or other, DO NOT use the battery. A battery with a odor of electrolyte or a gel leakage should be placed away from fire to avoid fire or explosion.

## **4. Battery Storage**

When storing the battery, it should be stored at room temperature, with a charge of at least 50%. We recommend that during long periods of storage that the battery be charged every 6 months. Doing this will prolong the life of the battery and will also make sure that the battery charge does not fall below the 30% mark.

## **5. Other Chemical Reaction**

Because batteries utilize a chemical reaction, battery performance will deteriorate over time even if stored for a long period of time without being used. In addition, if the various usage conditions such as charge, discharge, ambient temperature, etc. are not maintained within the specified ranges, the

life expectancy of the battery maybe shortened or the device in which the battery is used may be damaged by electrolyte gel leakage. If the batteries cannot maintain a charge for long periods of time, even when they are charged correctly, this may indicate it is time to change the battery.

## **6. Battery Disposal**

Please dispose of battery according to local regulations.

**Power Supply:** The ADJ Mega QA Go contains a automatic voltage switch, which will auto sense the voltage when it is plugged into the power source. With this switch there is no need to worry about the correct power voltage, this unit can be plugged in anywhere.

**DMX-512:** DMX is short for Digital Multiplex. This is a universal protocol used as a form of communication between intelligent fixtures and controllers. A DMX controller sends DMX data instructions from the controller to the fixture. DMX data is sent as serial data that travels from fixture to fixture via the DATA “IN” and DATA “OUT” XLR terminals located on all DMX fixtures (most controllers only have a DATA “OUT” terminal).

**DMX Linking:** DMX is a language allowing all makes and models of different manufactures to be linked together and operate from a single controller, as long as all fixtures and the controller are DMX compliant. To ensure proper DMX data transmission, when using several DMX fixtures try to use the shortest cable path possible. The order in which fixtures are connected in a DMX line does not influence the DMX addressing. For example; a fixture assigned a DMX address of 1 may be placed anywhere in a DMX line, at the beginning, at the end, or anywhere in the middle. When a fixture is assigned a DMX address of 1, the DMX controller knows to send DATA assigned to address 1 to that unit, no matter where it is located in the DMX chain.

**Data Cable (DMX Cable) Requirements (For DMX Operation):**

The Mega QA Go can be controlled via DMX-512 protocol. The Mega QA Go has 8 DMX modes, please see pages 11-12 for the different modes. The DMX address is set on the back panel of the Mega QA Go.

Your unit and your DMX controller require a standard 3-pin XLR connector for data input and data output (Figure 1). We recommend Accu-Cable DMX cables. If you are making your own cables, be sure to use standard 110-120 Ohm shielded cable (This cable may be purchased at almost all pro lighting stores). Your cables should be made with a male and female XLR connector on either end of the cable. Also remember that DMX cable must be daisy chained and cannot be split.



Figure 1

**Notice:** Be sure to follow figures two and three when making your own

cables. Do not use the ground lug on the XLR connector. Do not connect the cable’s shield conductor to the ground lug or allow the shield conductor to come in contact with the XLR’s outer casing. Grounding the shield could cause a short circuit and erratic behavior.

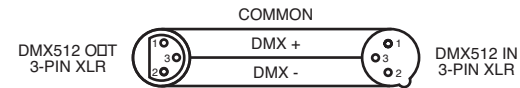

Figure 2

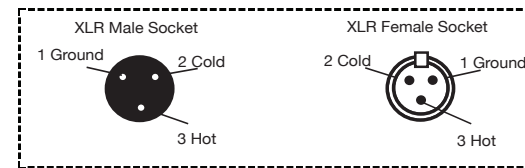

Figure 3

XLR Pin Configuration	
Pin 1 =	Ground
Pin 2 =	Data Compliment (negative)
Pin 3 =	Data True (positive)

**Special Note: Line Termination.** When longer runs of cable are used, you may need to use a terminator on the last unit to avoid erratic behavior. A terminator is a 110-120 ohm 1/4 watt resistor which is connected between pins 2 and 3 of a male XLR connector (DATA + and DATA -). This unit is inserted in the female XLR connector of the last unit in your daisy chain to terminate the line. Using a cable terminator (ADJ part number Z-DMX/T) will decrease the possibilities of erratic behavior.



Termination reduces signal errors and avoids signal transmission problems and interference. It is always advisable to connect a DMX terminal, (Resistance 120 Ohm 1/4 W) between PIN 2 (DMX-) and PIN 3 (DMX +) of the last fixture.

Figure 4

**5-Pin XLR DMX Connectors.** Some manufactures use 5-pin DMX-512 data cables for DATA transmission in place of 3-pin. 5-pin DMX fixtures may be implemented in a 3-pin DMX line. When inserting standard 5-pin data cables in to a 3-pin line a cable adaptor must be used, these adaptors are readily available at most electric stores. The chart below details a proper cable conversion.

3-Pin XLR to 5-Pin XLR Conversion		
Conductor	3-Pin XLR Female (Out)	5-Pin XLR Male (In)
Ground/Shield	Pin 1	Pin 1
Data Compliment (- signal)	Pin 2	Pin 2
Data True (+ signal)	Pin 3	Pin 3
Not Used		Do Not Use
Not Used		Do Not Use



**System Menu: The display will lock after 30 seconds, press the MODE button for 3 seconds to unlock.**

### **LED Display On/Off:**

To set the LED display to turn off after 10 seconds, press the MODE button until “don” is displayed, press the UP button to display “doff”. Now the display will disappear after 10s. Press any button to turn the display on again. Be advised though that the display will turn off automatically after 10 seconds.

To set the display press the MODE button until “dXX” is displayed. Use the UP or DOWN buttons to select either:  
 “don” = LED display on at all times.  
 “doff” = LED display shuts off after 10 seconds.

### **LED Display Inversion:**

Follow these instructions to flip the display 180° so that the display can be read upside down.

1. Plug the fixture in and press the MODE button until “dXX” is displayed. “XX” represents either “on” or “oFF”.
2. Press the SET UP button until “Std” is displayed.
3. Press the UP or DOWN buttons to reverse the display 180°.

### **Energy Saving Mode:**

1. Plug the fixture in and press the MODE button until “bXXX” is displayed. “XX” represents the current battery life.
2. Press the SET UP button so that “bSXX” is displayed.
3. Press the UP or DOWN buttons to turn energy saving mode either “On” or “Off”.

### **Operating Modes:**

The Mega QA Go has five operating modes:

- RGB Dimmer Mode - Choose one of the four colors to remain static or adjust the intensity of each color to make your desired color.
- Sound-Active mode - The unit will react to sound, chasing through the built in programs. There are 16 sound active modes.
- Auto Run Mode - In Auto Run mode, you can choose 1 of 16 color change modes, 1 of 16 color fade modes, or a combo color

change & fade mode.

- Static Color Mode - There are 64 colors to choose from.
- DMX control mode - This function will allow you to control each individual fixtures traits with a standard DMX 512 controller.

### **DMX Mode:**

Operating through a DMX controller gives the user the freedom to create their own programs tailored to their own individual needs. This function also allows you to use your fixtures as spot lights. The Mega QA Go has 8 DMX modes: 1 channel mode, 2 channel mode, 3 channel mode, 4 channel mode, 5 channel mode, 6 channel mode, 7 channel mode, and 8 channel mode. See page’s 20-27 for each mode’s DMX traits.

1. This function will allow you to control each individual fixture’s traits with a standard DMX 512 controller.
2. To run your fixture in DMX mode press the MODE button until “d.XXX” is displayed. “XXX” represents the current displayed DMX address. Use the UP or DOWN buttons to select your desired DMX address, then press the SETUP button to select your DMX Channel mode.
3. Use the UP or DOWN buttons to scroll through the DMX Channel modes. The Channel modes are listed below:
  - To run the 1 Channel Mode, press the MODE button until “Ch01” is displayed. This is the 1 Channel DMX Mode.
  - To run the 2 Channel Mode, press the MODE button until “Ch02” is displayed. This is the 2 Channel DMX Mode.
  - To run the 3 Channel Mode, press the MODE button until “Ch03” is displayed. This is the 3 Channel DMX Mode.
  - To run the 4 Channel Mode, press the MODE button until “Ch04” is displayed. This is the 4 Channel DMX Mode.
  - To run the 5 Channel Mode, press the MODE button until “Ch05” is displayed. This is the 5 Channel DMX Mode.
  - To run the 6 Channel Mode, press the MODE button until “Ch06” is displayed. This is the 6 Channel DMX Mode.
  - To run the 7 Channel Mode, press the MODE button until “Ch07” is displayed. This is the 7 Channel DMX Mode.
  - To run the 8 Channel Mode, press the MODE button until “Ch08” is displayed. This is the 8 Channel DMX Mode.

4. Please see pages 20-27 for DMX values and traits.
5. After you have chosen your desired DMX Channel mode plug in the fixture via the XLR connections to any standard DMX controller.

### **RGBA Dimmer Mode:**

1. Plug the fixture in and press the MODE button until:
2. When “r.XXX” is displayed you are in Red dimming mode. Press the UP and DOWN buttons to adjust intensity.
3. When “G.XXX” is displayed you are in Green dimming mode. Press the UP and DOWN buttons to adjust intensity.
4. When “b.XXX” is displayed you are in Blue dimming mode. Press the UP and DOWN buttons to adjust intensity.
5. When “A.XXX” is displayed you are in Amber dimming mode. Press the UP and DOWN buttons to adjust intensity.
6. After you have adjusted the RGBA colors to make your desired color you can then activate strobing by pressing the SET UP button to enter the Flash (strobe) mode.
7. “FS.XX” will be displayed, this is Flash mode. The Flash can be adjusted between “FS.00” (flash off) to “FS.15” (fastest flash).

### **Sound Active Mode:**

1. Plug the fixture in and press the MODE button until “SoXX” is displayed. “XX” represents the current sound active mode (1-16).
2. Use the UP or DOWN buttons to find your desired sound active mode.
3. Press the SET UP button to enter sound sensitivity adjustment. “SJ-X” will be displayed. Use the UP or DOWN buttons to adjust the sensitivity. “SJ-1” is the lowest sensitivity, “SJ-8” is the highest.

### **Auto Run Mode:**

There are 3 types of Auto Run Modes to choose from; Color Fade, Color Change, and both modes running together. The running speed is adjustable in all 3 modes.

1. Plug the fixture in and press the MODE button until either “AFXX”, “AJXX”, or “A-JF” is displayed.
  - AFXX = Color Fade mode, there are 16 Color Fade modes to choose from. Use the UP or DOWN buttons to scroll through the

- different Auto Fade modes.
- AJXX = Color Change mode, there are 16 Color Change modes to choose from. Use the UP or DOWN buttons to scroll through the different Auto Change modes.
  - A-JF = Both Color Fade and Color Change modes running.
2. After you have chosen your desired running mode press the SET UP button until “SP.XX” is displayed. When this is displayed you can adjust the running speed of your desired program. Use the UP or DOWN button to adjust the speed between “SP.01” (slowest) and “SP.16” (fastest). Once you have set your desired running speed, press the SET UP button to return to your desired Auto Run Mode.

### **Static Color Mode:**

1. Plug the fixture in and press the MODE button until “CLXX” is displayed.
2. There are 64 colors to choose from. Select your desired color by pressing the UP and DOWN buttons. After you have selected your desired color you can activate strobing by pressing the SET UP button to enter the Flash (strobe) mode.
3. “FS.XX” will be displayed, this is Flash mode. The Flash can be adjusted between “FS.00” (flash off) to “FS.15” (fastest flash).

### **DMX State:**

This mode can be used as a precaution mode, that in case the DMX signal is lost, the operating mode chosen in the setup is the running mode the fixture will go into when the DMX signal is lost. You can also set this as the operating mode you would like the unit to return to when power is applied.

1. Plug the fixture in and press the MODE button until “d.XXX” is displayed. “XXX” represents the current displayed DMX address.
2. Press the SET UP button so that “nodn” is displayed. Use the UP and DOWN buttons to scroll through the DMX states.
  - “bLAC” (Blackout) - If the DMX signal is lost or interrupted, the unit will automatically go into stand by mode.
  - “LASt” (Last State) - If the DMX signal is lost or interrupted, the fixture will stay in the last DMX set up. If power is applied and this mode is set, the unit will automatically go into the last DMX set up.

- “ProG” (Auto Run) - If the DMX signal is lost or interrupted, the unit will automatically go into Auto Run mode.
3. After you have found your desired setting, press SET UP to exit.

**Dimmer Curve:**

This is used to set the dimming curve used with DMX mode. See page 30 for the dimming curves chart.

1. Plug the fixture in and press the MODE button until “d.XXX” is displayed. “XXX” represents the current displayed DMX address.
2. Press the SET UP button until “dr-X” is displayed. “X” represents the displayed dimmer curve (0-4).
  - 0 - Standard
  - 1 - Stage
  - 2 - TV
  - 3 - Architectural
  - 4 - Theatre
3. Press the UP or DOWN buttons to scroll through and select your desired dimming curve.

**Activate IR Sensor:**

This function is used to activate and deactivate the IR sensor. When this function is activated you can control the fixture using the UC IR, or Airstream IR App. Please see page 16 for controls and functions.

1. Plug the fixture in and press the MODE button until “dXX” is displayed. “XX” represents either “on” or “off”.
2. Press the SET UP button until “IrXX” is displayed. “XX” represents either “on” or “off”.
3. Press the UP or DOWN buttons to either activate the remote function (On) or deactivate it (Off).

**Default Running Mode:**

This is a default running mode. When this mode is activated all modes will return to their default settings.

1. Plug the fixture in and press the MODE button until “dXX” is displayed. “XX” represents either “on” or “off”.
2. Press the SET UP button until “dEFA” is displayed.
3. Press the UP and DOWN buttons simultaneously. Press the MODE button to exit.

**Master-Slave Configuration:**

This function will allow you to link units together to run in a Master-Slave set-up. In a Master-Slave set-up one unit will act as the controlling unit and the others will react to the controlling units built-in programs. Any unit can act as a Master or as a Slave however, only one unit can be programmed to act as the “Master.”

**Master-Slave Connections and Settings:**

1. Daisy chain your units via the XLR connector on the rear of the unit. Use standard XLR data cables to link your units together. Remember that the Male XLR connector is the input and the Female XLR connector is the output. The first unit in the chain (master) will use the female XLR connector only. The last unit in the chain will use the male XLR connector only.
2. Connect the first “Slave” unit to the “Master.”
3. Set the “Master” unit to your desired mode of operation. Set the “Slave” unit(s) to the DMX address setting of 001. The “Slave” unit(s) will now follow the “Master”.

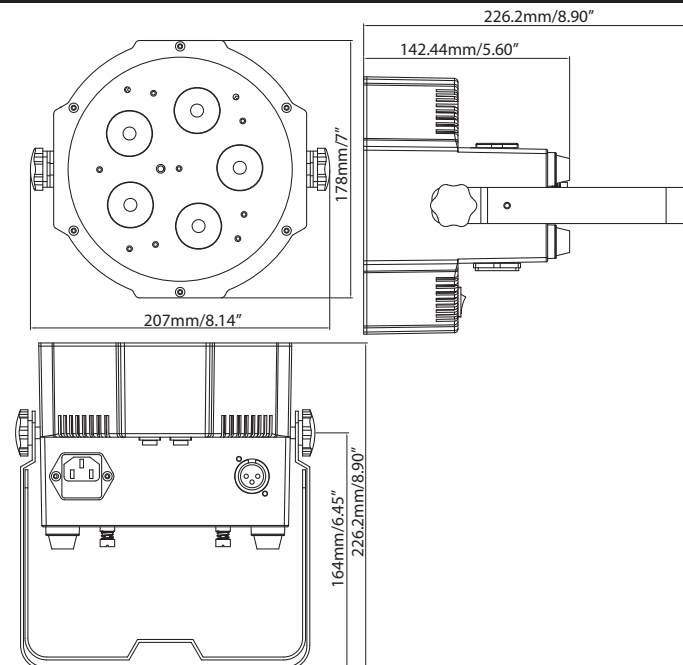



**Mega QA Go****UC IR & Airstream App Control**

The **UC IR (sold separately)** infrared remote gives you control of various functions (See below). To control the fixture you must aim the remote at the front of the fixture and be no more than 30 feet away. To use the ADJ UC IR you must first activate the fixtures infrared sensor, to activate the sensor please see the instructions on page 14.

The **Airstream IR (sold separately)** remote transmitter plugs into the headphone jack of your iOS phone or tablet. To control your IR fixture you must raise the volume to the maximum on your iOS phone or tablet and aim the transmitter at the fixture sensor and be no more than 15 feet away. After you have purchased the Airstream IR transmitters, the app is a free download from the app store for your iOS phone or tablet. The app comes with 3 pages of control depending on the fixture you are using. Please see below for IR functions including the corresponding app page.

**Works with App page 1.**

**STAND BY** - Pressing this button will blackout the fixture. Press the button again to return to the initial state.

**FULL ON** - Hold this button down to fully light up the unit. When you let the button go, the unit will return to its previous state.

**FADE/GOBO** - This button activates color fade mode.

**“DIMMER +” and “DIMMER -”** - These buttons are used to adjust the color output intensity in static color mode.

**STROBE** - Press and hold this button for strobing.

**COLOR** - Press this button to activate color mode. Use buttons 1-9 to find your desired color.

**1-9** - Use buttons 1-9 to select your desired color when color mode is active, and your desired show when show mode is active.

**SOUND ON & OFF** - Use the buttons to activate and deactivate sound active mode.

**SHOW 0** - Press this button to activate show mode. Use buttons 1-9 to find your desired show. Press the Show 0 button twice to run show 10, and button 1 twice to run show 11.

**Mega QA Go****1 Channel Mode**

Channel	Value	Function
1	0 - 255	COLOR MACROS See the Color Macro Chart on page 23

**Mega QA Go****2 Channel Mode**

Channel	Value	Function
1	0 - 255	COLOR MACROS See the Color Macro Chart on page 23
2	0 - 255	MASTER DIMMER 0% - 100%

**Mega QA Go****3 Channel Mode**

Channel	Value	Function
1	0 - 255	COLOR MACROS See the Color Macro Chart on page 23
2	0 - 255	MASTER DIMMER 0% - 100%
3	0 - 15 16 - 255	STROBE OFF STROBING SLOW - FAST

**Mega QA Go****4 Channel Mode**

Channel	Value	Function
1	0 - 255	RED 0% - 100%
2	0 - 255	GREEN 0% - 100%
3	0 - 255	BLUE 0% - 100%
4	0 - 255	AMBER 0% - 100%

Mega QA Go		5 Channel Mode
Channel	Value	Function
1	0 - 255	RED 0% - 100%
2	0 - 255	GREEN 0% - 100%
3	0 - 255	BLUE 0% - 100%
4	0 - 255	AMBER 0% - 100%
5	0 - 255	MASTER DIMMER 0% - 100%

Mega QA Go		6 Channel Mode
Channel	Value	Function
1	0 - 255	RED 0% - 100%
2	0 - 255	GREEN 0% - 100%
3	0 - 255	BLUE 0% - 100%
4	0 - 255	AMBER 0% - 100%
5	0 - 255	MASTER DIMMER 0% - 100%
6	0 - 255	COLOR MACROS See the Color Macro Chart on page 23

Mega QA Go		7 Channel Mode
Channel	Value	Function
1	0 - 255	RED 0% - 100%
2	0 - 255	GREEN 0% - 100%
3	0 - 255	BLUE 0% - 100%
4	0 - 255	AMBER 0% - 100%
5	0 - 255	MASTER DIMMER 0% - 100%
6	0 - 15 16 - 255	STROBE OFF STROBING SLOW - FAST
7	0 - 255	COLOR MACROS See the Color Macro Chart on page 23

Mega QA Go		8 Channel Mode
Channel	Value	Function
1	0 - 255	RED 0% - 100%
2	0 - 255	GREEN 0% - 100%
3	0 - 255	BLUE 0% - 100%
4	0 - 255	AMBER 0% - 100%
5	0 - 255	MASTER DIMMER 0% - 100%
6	0 - 15 16 - 255 0 - 255 0 - 255	STROBE/PROGRAM SPEED/ SOUND SENSITIVITY STROBING OFF STROBING SLOW - FAST PROGRAM SPEED SLOW - FAST SOUND LEAST SENS - MOST SENS
7	0 - 51 52 - 102 103 - 153 154 - 204 205 - 255	PROGRAM SELECTION MODE DIMMING MODE COLOR MACRO MODE COLOR CHANGE MODE COLOR FADE MODE SOUND ACTIVE MODE
8	0 - 255  0 - 15 16 - 31 32 - 47 48 - 63 64 - 79 80 - 95	COLOR MACROS/PROGRAMS/ SOUND ACTIVITY  COLOR MACRO MODE See the Color Macro Chart on page 23  COLOR CHANGE PROGRAMS COLOR CHANGE 1 COLOR CHANGE 2 COLOR CHANGE 3 COLOR CHANGE 4 COLOR CHANGE 5 COLOR CHANGE 6

Mega QA Go		8 Channel Mode
Channel	Value	Function
8	96 - 111 112 - 127 128 - 143 144 - 159 160 - 175 176 - 191 192 - 207 208 - 223 224 - 239 240 - 255  0 - 15 16 - 31 32 - 47 48 - 63 64 - 79 80 - 95 96 - 111 112 - 127 128 - 143 144 - 159 160 - 175 176 - 191 192 - 207 208 - 223 224 - 239 240 - 255	COLOR MACROS/PROGRAMS/ SOUND ACTIVITY  COLOR CHANGE PROGRAMS COLOR CHANGE 7 COLOR CHANGE 8 COLOR CHANGE 9 COLOR CHANGE 10 COLOR CHANGE 11 COLOR CHANGE 12 COLOR CHANGE 13 COLOR CHANGE 14 COLOR CHANGE 15 COLOR CHANGE 16  COLOR FADE PROGRAMS COLOR FADE 1 COLOR FADE 2 COLOR FADE 3 COLOR FADE 4 COLOR FADE 5 COLOR FADE 6 COLOR FADE 7 COLOR FADE 8 COLOR FADE 9 COLOR FADE 10 COLOR FADE 11 COLOR FADE 12 COLOR FADE 13 COLOR FADE 14 COLOR FADE 15 COLOR FADE 16

Channel	Value	Function
8		COLOR MACROS/PROGRAMS/ SOUND ACTIVITY
		SOUND ACTIVE PROGRAMS
	0 - 15	SOUND ACTIVE MODE 1
	16 - 31	SOUND ACTIVE MODE 2
	32 - 47	SOUND ACTIVE MODE 3
	48 - 63	SOUND ACTIVE MODE 4
	64 - 79	SOUND ACTIVE MODE 5
	80 - 95	SOUND ACTIVE MODE 6
	96 - 111	SOUND ACTIVE MODE 7
	112 - 127	SOUND ACTIVE MODE 8
	128 - 143	SOUND ACTIVE MODE 9
	144 - 159	SOUND ACTIVE MODE 10
	160 - 175	SOUND ACTIVE MODE 11
	176 - 191	SOUND ACTIVE MODE 12
	192 - 207	SOUND ACTIVE MODE 13
	208 - 223	SOUND ACTIVE MODE 14
	224 - 239	SOUND ACTIVE MODE 15
	240 - 255	SOUND ACTIVE MODE 16

When Channel 7 is between the values of 0-51, Channels 1-4 are used, and Channel 6 will control strobing.

When Channel 7 is between the values of 52-102, Channel 8 is in Color Macros Mode, and Channel 6 will control strobing.

When Channel 7 is between the values of 103-153, Channel 8 is in Color Change Mode, and Channel 6 will control the color change speed.

When Channel 7 is between the values of 154-204, Channel 8 is in Color Fade Mode, and Channel 6 will control the color fade speed.

When Channel 7 is between the values of 205-255, Channel 8 is in Sound Active Mode, and Channel 6 will control the sound sensitivity.

Color No.	DMX VAULE	RGB COLOR INTENSITY			Color No.	DMX VAULE	RGB COLOR INTENSITY				
		RED	GREEN	BLUE			RED	GREEN	BLUE		
OFF	0	0	0	0	Color33	129-132	255	206	143	0	0
Color1	1-4	80	255	234	Color34	133-136	254	177	153	0	0
Color2	5-8	80	255	164	Color35	137-140	254	192	138	0	0
Color3	9-12	77	255	112	Color36	141-144	254	165	98	0	0
Color4	13-16	117	255	83	Color37	145-148	254	121	0	0	0
Color5	17-20	160	255	77	Color38	149-152	176	17	0	0	0
Color6	21-24	223	255	83	Color39	153-156	96	0	11	0	0
Color7	25-28	255	243	77	Color40	157-160	234	139	171	0	0
Color8	29-32	255	200	74	Color41	161-164	224	5	97	0	0
Color9	33-36	255	166	77	Color42	165-168	175	77	173	0	0
Color10	37-40	255	125	74	Color43	169-172	119	130	199	0	0
Color11	41-44	255	97	77	Color44	173-176	147	164	212	0	0
Color12	45-48	255	71	77	Color45	177-180	88	2	163	0	0
Color13	49-52	255	83	134	Color46	181-184	0	38	86	0	0
Color14	53-56	255	93	182	Color47	185-188	0	142	208	0	0
Color15	57-60	255	96	236	Color48	189-192	52	148	209	0	0
Color16	61-64	238	93	255	Color49	193-196	1	134	201	0	0
Color17	65-68	196	87	255	Color50	197-200	0	145	212	0	0
Color18	69-72	150	90	255	Color51	201-204	0	121	192	0	0
Color19	73-76	100	77	255	Color52	205-208	0	129	184	0	0
Color20	77-80	77	100	255	Color53	209-212	0	83	115	0	0
Color21	81-84	67	148	255	Color54	213-216	0	97	166	0	0
Color22	85-88	77	195	255	Color55	217-220	1	100	167	0	0
Color23	89-92	77	234	255	Color56	221-224	0	40	86	0	0
Color24	93-96	158	255	144	Color57	225-228	209	219	182	0	0
Color25	97-100	255	251	153	Color58	229-232	42	165	85	0	0
Color26	101-104	255	175	147	Color59	233-236	0	46	35	0	0
Color27	105-108	255	138	186	Color60	237-240	8	107	222	0	0
Color28	109-112	255	147	251	Color61	241-244	107	156	231	0	0
Color29	113-116	151	138	255	Color62	245-248	165	198	247	0	0
Color30	117-120	151	138	255	Color63	249-252	0	0	189	0	0
Color31	121-124	138	169	255	Color64	253-255	255	255	255	0	0
Color32	125-128	255	255	255							

**Battery Status:**

This function is used to check the life status of the battery. Plug the fixture in and press the MODE button until “bXXX” is displayed. “XXX” represents an number between “000” and “100”. The number that is displayed is the remaining battery life. If “b---” is displayed, it means the battery is dead or you are running the unit on AC power. **Please do not let the battery fully die, this severely shortens the life of the battery.**

**Example:** If “b050” is displayed, the battery is at half life. If “b025” is displayed, the battery is at 25% life.

**NOTE:** When the battery is charging or if the battery life is below 30% the digital display will flash.

**NOTE:** After 20 seconds of inactivity, the display will revert back to the battery life display.

**Battery Recharge:** To recharge the battery, plug the supplied AC cord into the AC input on the side of the unit and plug the other end into a matching power supply. It takes about 4 hours to reach full charge. **The display will STOP flashing when the unit reaches 100% charge.**

**Note:** When unplugging the unit from charging and then applying power via battery, there will be a minimal charge drop.

For a faster recharge, put the Load Switch in the “Off” position and the Battery Switch in the “ON” position.

R	D40	1201	300	126.3	67.5	43.5	lux
G	D40	1038	244	104.7	61.2	37.5	
B	D40	1124	286	124.4	66.7	42.9	
A	D40	607	176.8	71.4	36.5	23	
RGBA	D40	2830	622	305	182.3	109.4	

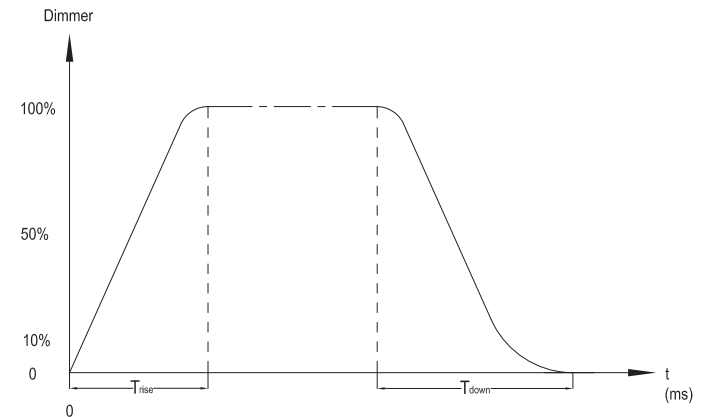
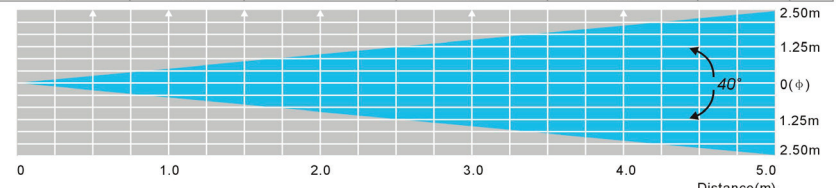

Ramp Effect	0  255 0S (Fade Time)		0  255 1S (Fade Time)	
	T <sub>rise</sub> (ms)	T <sub>down</sub> (ms)	T <sub>rise</sub> (ms)	T <sub>down</sub> (ms)
Standard	0	0	0	0
Stage	780	1100	1540	1660
TV	1180	1520	1860	1940
Architectural	1380	1730	2040	2120
Theatre	1580	1940	2230	2280



## Mega QA Go

## Power Cord Daisy Chain

**With this feature you can connect the fixtures to one another using the IEC input and output sockets. The quantity that can be connected is 20 fixtures maximum. After 20 fixtures you will need to use a new power outlet. They must be the same fixtures. DO NOT mix fixtures.**

## Mega QA Go

## Fuse Replacement

Disconnect the unit from its power source. Remove the power cord from the unit. Once the cord has been removed, you will find that the fuse holder is located inside the power socket. Insert a flat-head screw driver into the power socket and gently pry out the fuse holder. Remove the bad fuse and replace with a new one. The fuse holder also has a holder for a spare fuse.

## Mega QA Go

## Trouble Shooting

Listed below are a few common problems the user may encounter, with solutions.

### **Unit not responding to DMX:**

1. Check that the DMX cables are connected properly and are wired correctly (pin 3 is “hot”; on some other DMX devices pin 2 may be ‘hot’). Also, check that all cables are connected to the right connectors; it does matter which way the inputs and outputs are connected.

### **Unit does not respond to sound:**

1. Quiet or high pitched sounds will not activate the unit.
2. Make sure that Sound Active mode is activated.

## Mega QA Go

## Cleaning

Due to fog residue, smoke, and dust cleaning the internal and external optical lenses must be carried out periodically to optimize light output.

1. Use normal glass cleaner and a soft cloth to wipe down the outside casing.
2. Clean the external optics with glass cleaner and a soft cloth every 20 days.
3. Always be sure to dry all parts completely before plugging the unit back in.

Cleaning frequency depends on the environment in which the fixture operates (i.e. smoke, fog residue, dust, dew).

## Mega QA Go

## Warranty

### MANUFACTURER'S LIMITED WARRANTY

- A. ADJ Products, LLC hereby warrants, to the original purchaser, ADJ Products, LLC products to be free of manufacturing defects in material and workmanship for a prescribed period from the date of purchase (see specific warranty period on reverse). This warranty shall be valid only if the product is purchased within the United States of America, including possessions and territories. It is the owner's responsibility to establish the date and place of purchase by acceptable evidence, at the time service is sought.
- B. For warranty service you must obtain a Return Authorization number (RA#) before sending back the product—please contact ADJ Products, LLC Service Department at 800-322-6337. Send the product only to the ADJ Products, LLC factory. All shipping charges must be pre-paid. If the requested repairs or service (including parts replacement) are within the terms of this warranty, ADJ Products, LLC will pay return shipping charges only to a designated point within the United States. If the entire instrument is sent, it must be shipped in its original package. No accessories should be shipped with the product. If any accessories are shipped with the product, ADJ Products, LLC shall have no liability whatsoever for loss of or damage to any such accessories, nor for the safe return thereof.
- C. This warranty is void if the serial number has been altered or removed; if the product is modified in any manner which ADJ Products, LLC concludes, after inspection, affects the reliability of the product; if the product has been repaired or serviced by anyone other than the ADJ Products, LLC factory unless prior written authorization was issued to purchaser by ADJ Products, LLC; if the product is damaged because not properly maintained as set forth in the instruction manual.
- D. This is not a service contract, and this warranty does not include maintenance, cleaning or periodic check up. During the period specified above, ADJ Products, LLC will replace defective parts at its expense with new or refurbished parts, and will absorb all expenses for warranty service and repair labor by reason of defects in material or workmanship. The sole responsibility of ADJ Products, LLC under this warranty shall be limited to the repair of the product, or replacement thereof, including parts, at the sole discretion of ADJ Products, LLC. All products covered by this warranty were manufactured after August 15, 2012, and bear identifying marks to that effect.
- E. ADJ Products, LLC reserves the right to make changes in design and/or improvements upon its products without any obligation to include these changes in any products theretofore manufactured.

No warranty, whether expressed or implied, is given or made with respect to any accessory supplied with products described above. Except to the extent prohibited by applicable law, all implied warranties made by ADJ Products, LLC in connection with this product, including warranties of merchantability or fitness, are limited in duration to the warranty period set forth above. And no warranties, whether expressed or implied, including warranties of merchantability or fitness, shall apply to this product after said period has expired. The consumer's and/or Dealer's sole remedy shall be such repair or replacement as is expressly provided above; and under no circumstances shall ADJ Products, LLC be liable for any loss or damage, direct or consequential, arising out of the use of, or inability to use, this product.

This warranty is the only written warranty applicable to ADJ Products, LLC Products and supersedes all prior warranties and written descriptions of warranty terms and conditions heretofore published.

### MANUFACTURER'S LIMITED WARRANTY PERIODS:

- **Non L.E.D. Lighting Products = 1-year (365 days) Limited Warranty** (Such as: Special Effect Lighting, Intelligent Lighting, UV lighting, Strobes, Fog Machines, Bubble Machines, Mirror Balls, Par Cans, Trussing, Lighting Stands etc. excluding LED and lamps)
- **Laser Products = 1 Year (365 Days) Limited Warranty** (excluding laser diodes which have a 6 month limited warranty)
- **L.E.D. Products = 2-year (730 days) Limited Warranty** (excluding batteries which have a 180 day limited warranty). **Note: 2 Year Warranty only applies to purchases within the United States.**
- **StarTec Series = 1 Year Limited Warranty** (excluding batteries which have a 180 day limited warranty).
- **ADJ DMX Controllers = 2 Year (730 Days) Limited Warranty**



**Model: Mega QA Go**

Voltage:	100V ~ 240V/50~60Hz
LEDs:	5 x 4W RGBA (4-in-1)
Beam Angle:	40 Degrees
Working Position:	Any safe working position
Power Draw:	28W
Power Cord Daisy Chain:	20 Fixtures Max.
Fuse:	2 Amp
Weight:	4lbs./ 1.9Kgs.
Dimensions:	5.5" (L) x 9" (W) x 10" (H) 253 x 227 x 140mm
Colors:	RGBA Mixing
DMX Channels:	8 DMX Modes: 1 Channel Mode, 2 Channel Mode, 3 Channel Mode, 4 Channel Mode, 5 Channel Mode, 6 Channel Mode, 7 Channel Mode, & 8 Channel Mode
Battery Charge Time:	4 Hours (With Load Switch OFF)
Battery Life w/ Full Charge:	16 Hours (Single Color) 16 Hours (Sound Active) 16 Hours (Fade Mode) 7 Hours (Full On)
Battery Lifetime*:	Average Lifetime is 500 Charges
Battery Type:	Fixed Lithium Battery
Battery Energy:	73.26WH (Watt Hours)
Battery Weight:	1lbs. / 0.42kg
Battery Voltage:	11.1V
Battery Capacity:	6.6AH
Total Lithium Ion Cells:	9pcs
Battery Wrap Material:	PVC Sleeving + Highland Barley Paper
Warranty:	2 Year (730 days)

\*This depends on charging frequency

**Please Note:** Specifications and improvements in the design of this unit and this manual are subject to change without any prior written notice.

ADJ Products, LLC  
6122 S. Eastern Ave. Los Angeles, CA 90040 USA  
Tel: 323-582-2650 / Fax: 323-725-6100  
Web: www.adj.com / E-mail: info@americandj.com

A.D.J. Supply Europe B.V.  
Junostraat 2  
6468 EW Kerkrade  
Netherlands

Follow Us On:



facebook.com/americandj  
twitter.com/americandj  
youtube.com/adjlighting

service@adjgroup.eu / www.adj.eu  
Tel: +31 45 546 85 00 / Fax: +31 45 546 85 99