

# elumen8

## **Fury 400 DTW 4 Cell Blinder** User Manual



Order codes: ELUM431

### WARNING

## FOR YOUR OWN SAFETY, PLEASE READ THIS USER MANUAL CAREFULLY BEFORE YOUR INITIAL START-UP!

- Before your initial start-up, please make sure that there is no damage caused during transportation.
- Should there be any damage, consult your dealer and do not use the equipment.
- To maintain the equipment in good working condition and to ensure safe operation, it is necessary for the user to follow the safety instructions and warning notes written in this manual.
- Please note that damages caused by user modifications to this equipment are not subject to warranty.



### IMPORTANT:

The manufacturer will not accept liability for any resulting damages caused by the non-observance of this manual or any unauthorised modification to the equipment.

- Never let the power cable come into contact with other cables. Handle the power cable and all mains voltage connections with particular caution!
- Never remove warning or informative labels from the unit.
- Do not open the equipment and do not modify the unit.
- Do not connect this equipment to a dimmer pack.
- Do not switch the equipment on and off in short intervals, as this will reduce the system's life.
- Only use the equipment indoors.
- Do not expose to flammable sources, liquids or gases.
- Always disconnect the power from the mains when equipment is not in use or before cleaning! Only handle the power-cable by the plug. Never pull out the plug by pulling the power-cable.
- Make sure that the available mains supply voltage is between 100~240V AC, 50/60Hz.
- Make sure that the power cable is never crimped or damaged. Check the equipment and the power cable periodically.
- If the equipment has been exposed to drastic temperature fluctuation (e.g. after transportation), do not connect power or switch it on immediately. The arising condensation might damage the equipment. Leave the equipment switched off until it has reached room temperature.
- Never touch the fixture during operation as it may be hot.
- If the equipment is dropped or damaged, disconnect the mains power supply immediately and have a qualified engineer inspect the equipment before operating again.
- If your product fails to function correctly, stop use immediately. Pack the unit securely (preferably in the original packing material), and return it to your Pro Light dealer for service.
- Only use fuses of same type and rating.
- Repairs, servicing and power connection must only be carried out by a qualified technician. THIS UNIT CONTAINS NO USER SERVICEABLE PARTS.
- This lighting fixture is for professional use only - it is not designed for or suitable for household use. The product must be installed by a qualified technician in accordance with local territory regulations. The safety of the installation is the responsibility of the installer. The fixture presents risks of severe injury or death due to fire hazards, electric shock and falls.
- Warning! Risk Group 2 LED product according to EN 62471. Do not view the light output with optical instruments or any device that may concentrate the beam.
- WARRANTY: Two years from date of purchase.

### OPERATING DETERMINATIONS

If this equipment is operated in any other way, than those described in this manual, the product may suffer damage and the warranty becomes void. Incorrect operation may lead to danger e.g: short-circuit, burns and electric shocks etc.

Do not endanger your own safety and the safety of others!

Incorrect installation or use can cause serious damage to people and/or property.

### Fury 400 DTW 4 Cell Blinder

The Fury IP65 rated blinders are loaded with 90W individually addressable amber and warm white COB LEDs, which emulate the dimming and colour temperature of a halogen lamp. Each cell features an RGB backlight creating a truly versatile series, ideal for rental and installation, backed up with the eLumen8 2 year warranty.

- 4 x 90W amber and warm white COB LEDs (1800K/3200K)
- RGB backlights for 'eye-candy' effects
- Beam angle: 50°
- 8,562 Lux @ 2m
- 12kHz refresh rate
- Individually addressable LEDs
- DMX channels: 1/4/4/7/9/18/20/23 or 27 selectable
- RDM (Remote Device Management)
- Static colour, colour change, colour fade, auto and master/slave modes plus built-in programs
- 0-100% dimming and variable strobe
- 4 dimming curves: Linear, square law, inverse square law and S-curve
- 4 button menu with OLED display
- PowerCON TRUE1 input/output
- IP rated 5-Pin XLR input/output
- Fan cooled



Specifications	Fury 400 DTW
Power consumption	395W
Power supply	100~240V, 50/60Hz
Fuse	F6A 250V
IP rating	IP65
Dimensions	398 x 398 x 215mm
Weight	11kg
Order code	ELUM431

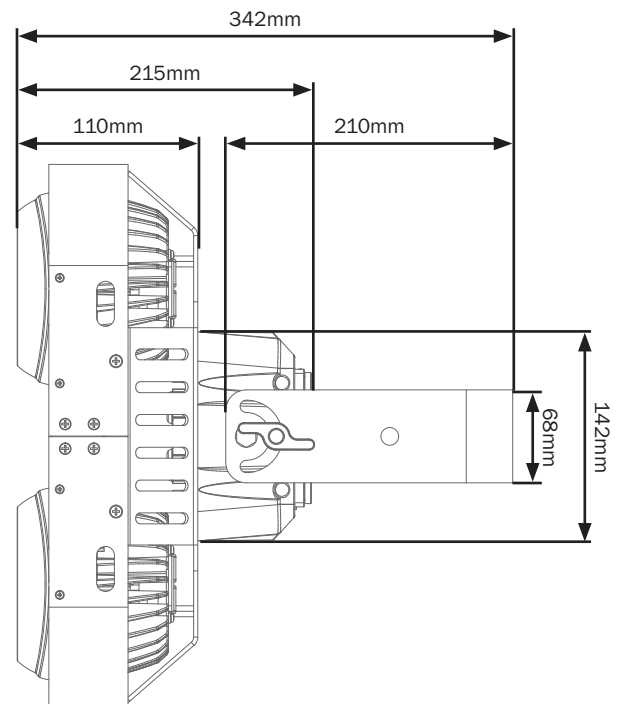
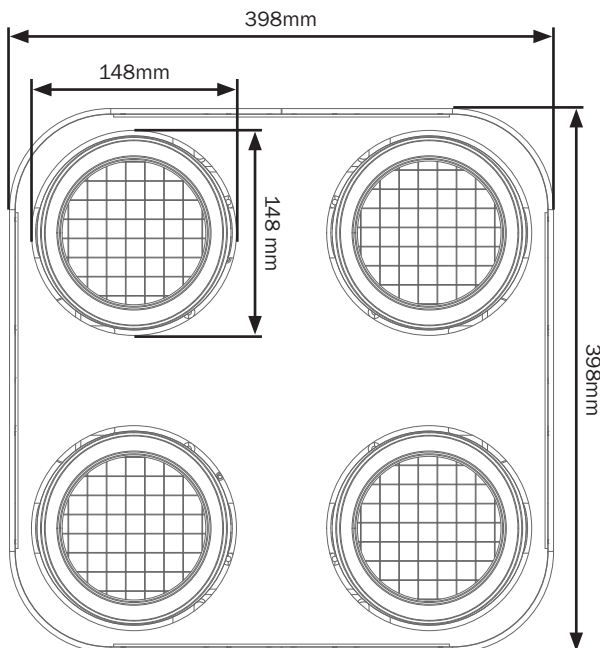
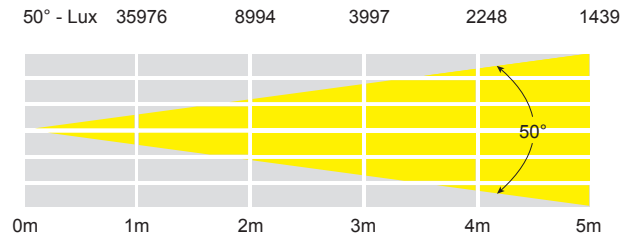

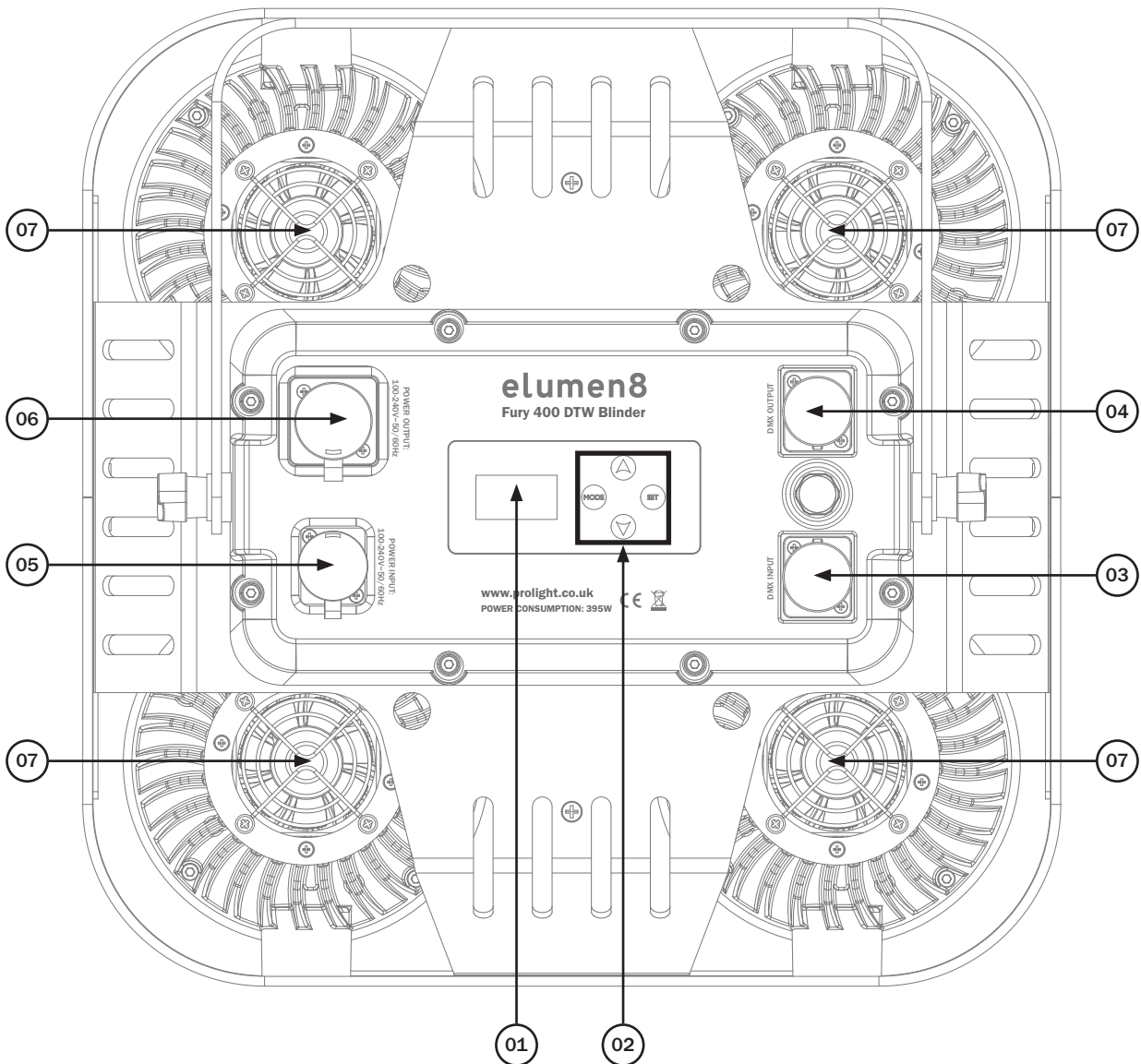

01 - OLED display

02 - Function buttons

03 - IP rated 5-Pin DMX input

04 - IP rated 5-Pin DMX output

05 - PowerCON TRUE1 input

06 - PowerCON TRUE1 output

07 - Fans

In the box: **1 x fixture,**  
**1 x power cable**  
**& 1 x user manual**

**Fuse:** The Fury 400 Blinder is fitted with an internal mains (line) fuse. The fuse must only be changed by qualified personnel. Before opening the fixtures housing or changing the fuse, the fixture must be disconnected and isolated from the mains supply. Replacement cartridge fuses must be of the same type and rating (20mm Glass F6A 250V). When closing the fixture please ensure the seal is correctly positioned and free from damage to ensure the fixture is water tight and to prevent water ingress.

Before installing the fixture, the supporting structure (ie. truss) must be able to hold a minimum of 10 times the fixtures weight without any deformation (eg. 15kg - 150kg point load). The fixture must be secured with a secondary safety attachment when being installed (ie. an appropriate safety cable). Never stand directly below the fixture when mounting, removing, and/or servicing.

Overhead installation requires experience and qualifications to calculate working load limits, the material being used at the installation area and periodic safety inspections of the fixture and installation material. If you do not have the relevant experience and/or qualifications please do not attempt the installation yourself. The installation should be checked annually by a qualified person.

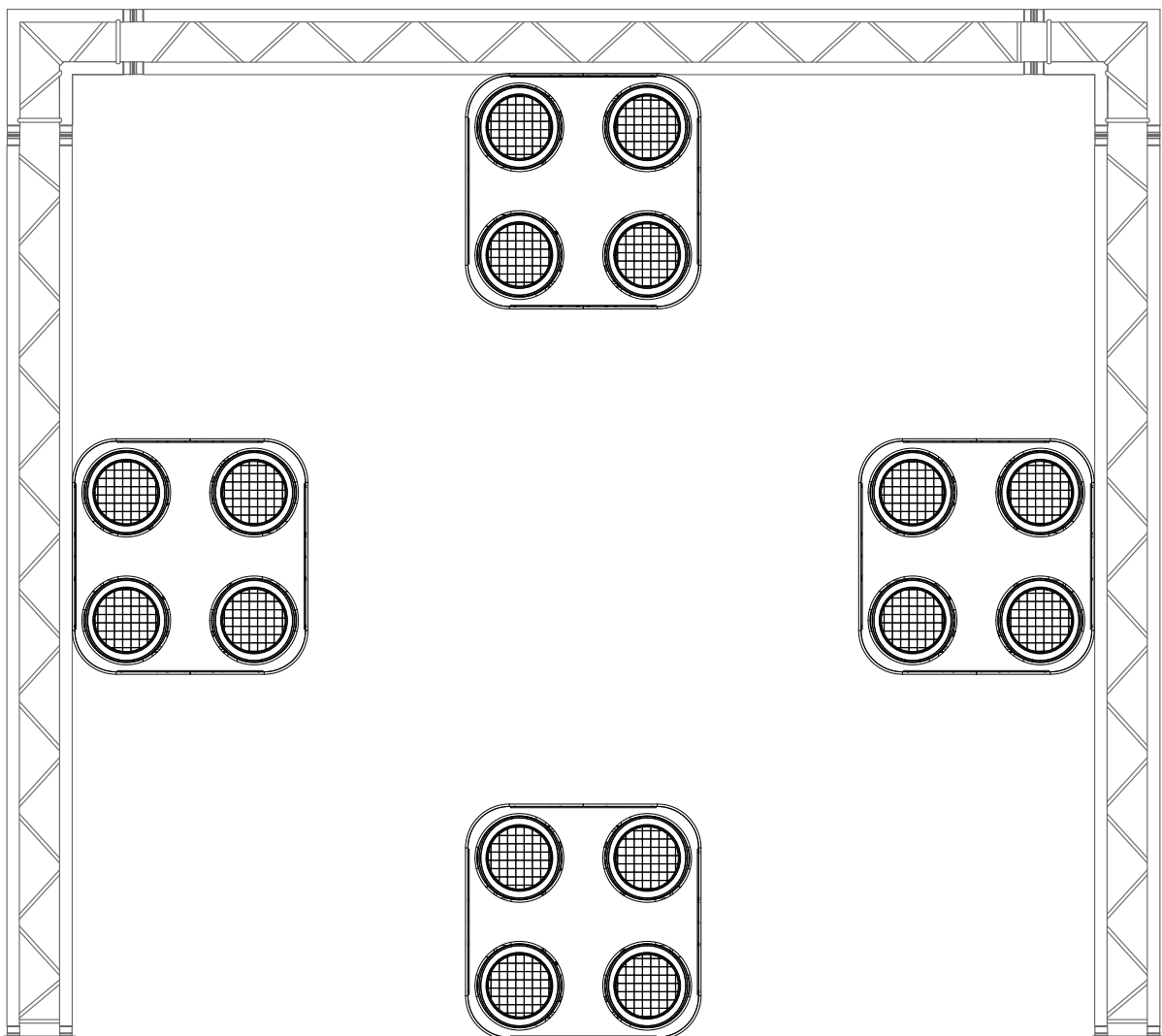

The eLumen8 Fury 400 can be operated in a number of mounting positions as shown in the diagram above, hanging upside-down from the ceiling or truss, mounting sideways on truss or stood upright on a flat level surface. Always use a safety wire as an extra safety precaution to prevent damage/injury in the event a clamp fails (see the next page for clamp installation). Never use the carry handles for secondary attachments.

### Installation:

1. Fasten the clamp to the fixtures bracket.
2. Mount the fixture onto your truss system via the clamps and tighten to ensure secure.
3. Pull the safety cable through the safety cable holes located on the metal base plate on the underside of the fixture and around the truss.

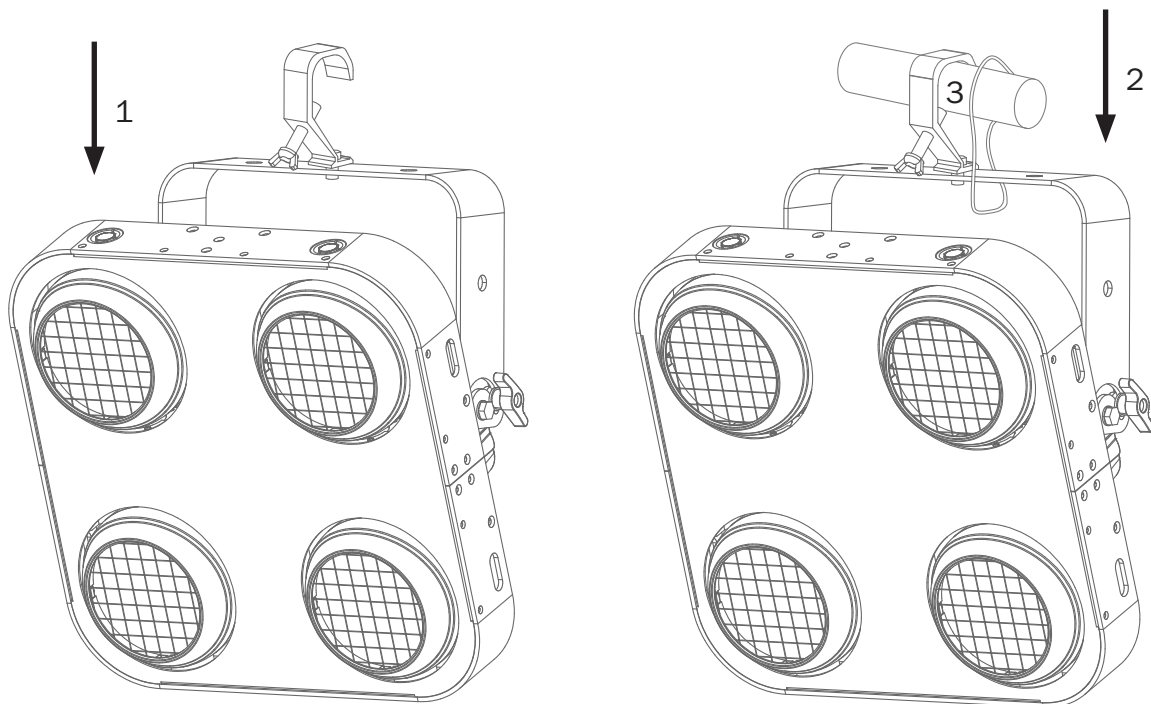

**Control Panel Menu:**

The OLED control panel situated on the front of the fixture allows the user to access the menu system to adjust the fixtures settings.

When the unit has been powered on the display will show “**Versions**” followed by “**xx °C xx °C xx °C xx °C**”. The fixture will then return to its home screen.

Pressing the “**MODE**” button once will take the user to the fixtures main menu. Using the “**UP**” and “**DOWN**” buttons you can then navigate between the different options in the main menu. Pressing the “**SET**” button on one of these options allows you to access the sub menu where you can use the “**UP**” and “**DOWN**” buttons to select option/value required. Once the option/value has been selected press the “**SET**” button once more to confirm the setting.

To exit out of any of the above options, press and hold the “**MENU**” button.

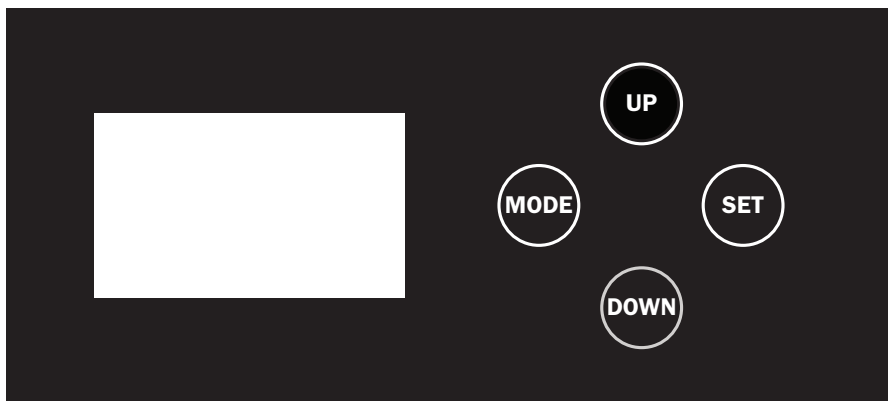

**IMPORTANT! PLEASE NOTE:** The OLED display for this fixture has a menu locking function where after 30 seconds of inactivity it will lock. To unlock the menu hold the “**MODE**” and “**SET**” buttons for 3 seconds.

Main Menu - Defaults are in grey

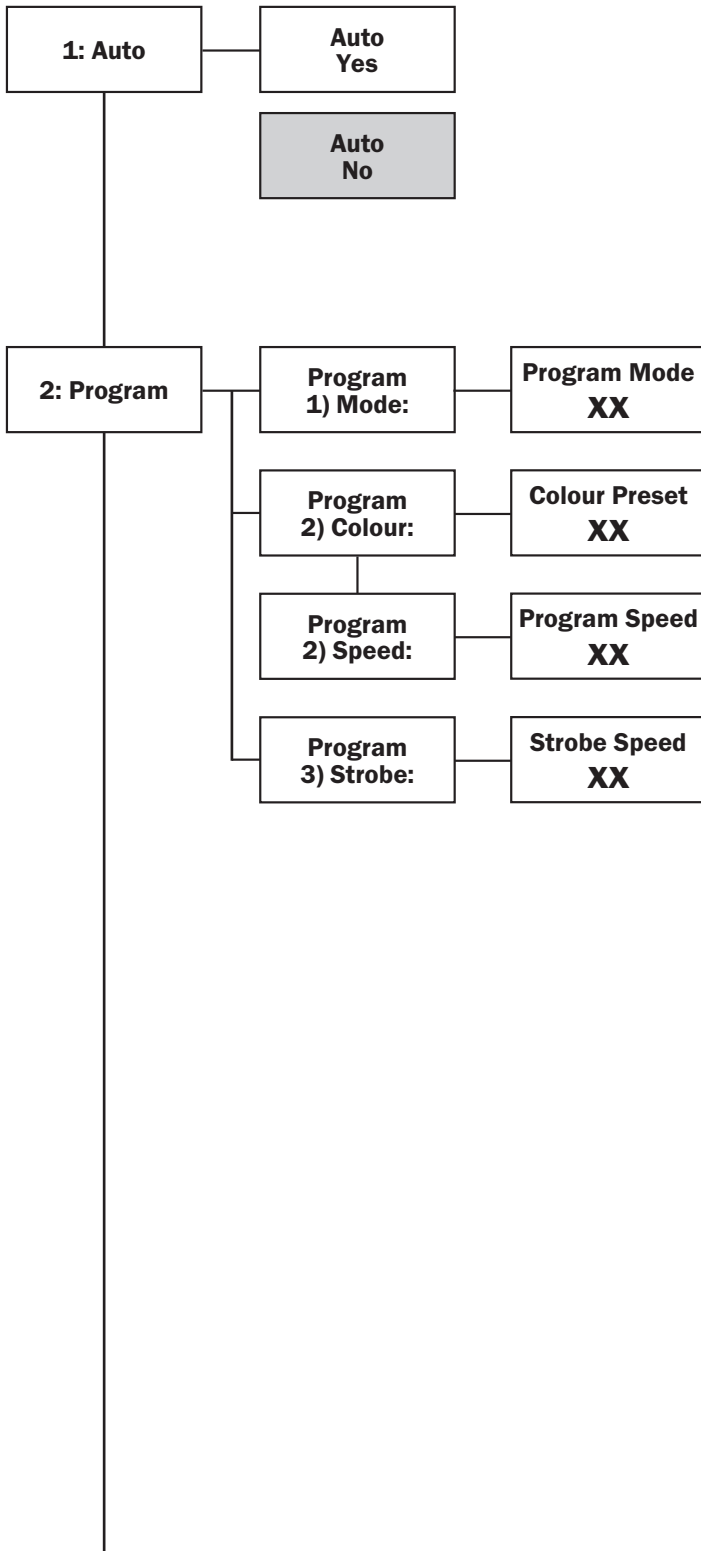

### Auto mode:

To access auto mode, press the “**MODE**” button until “**1: Auto**” is highlighted on the OLED display. Press the “**SET**” button and use the “**UP**” and “**DOWN**” buttons to select between “**Yes**” and “**No**”. Press the “**SET**” button to enter auto mode when yes is selected.

### Built-in programs:

To access the built-in programs, press the “**MODE**” button until “**2: Program**” is highlighted on the OLED display. Press the “**SET**” button and use the “**UP**” and “**DOWN**” buttons to highlight “**1) Mode**”. Press the “**SET**” button and use the “**UP**” and “**DOWN**” buttons to select the program mode required between 01-23. Press the “**SET**” button to confirm the setting.

If program mode 01 is selected use the “**UP**” and “**DOWN**” buttons to highlight “**2) Colour**”. Press the “**SET**” button and use the “**UP**” and “**DOWN**” buttons to select the colour required between 01-21. Press the “**SET**” button to confirm the setting.

If program mode 02-23 is selected use the “**UP**” and “**DOWN**” buttons to highlight “**2) Speed**”. Press the “**SET**” button and use the “**UP**” and “**DOWN**” buttons to select the speed required between 001-100. Press the “**SET**” button to confirm the setting.

Now use the “**UP**” and “**DOWN**” buttons to highlight “**3) Strobe**”. Press the “**SET**” button and use the “**UP**” and “**DOWN**” buttons to select the strobe speed required between 00-99.

Press the “**SET**” button to confirm the setting.



Main Menu - Defaults are in grey

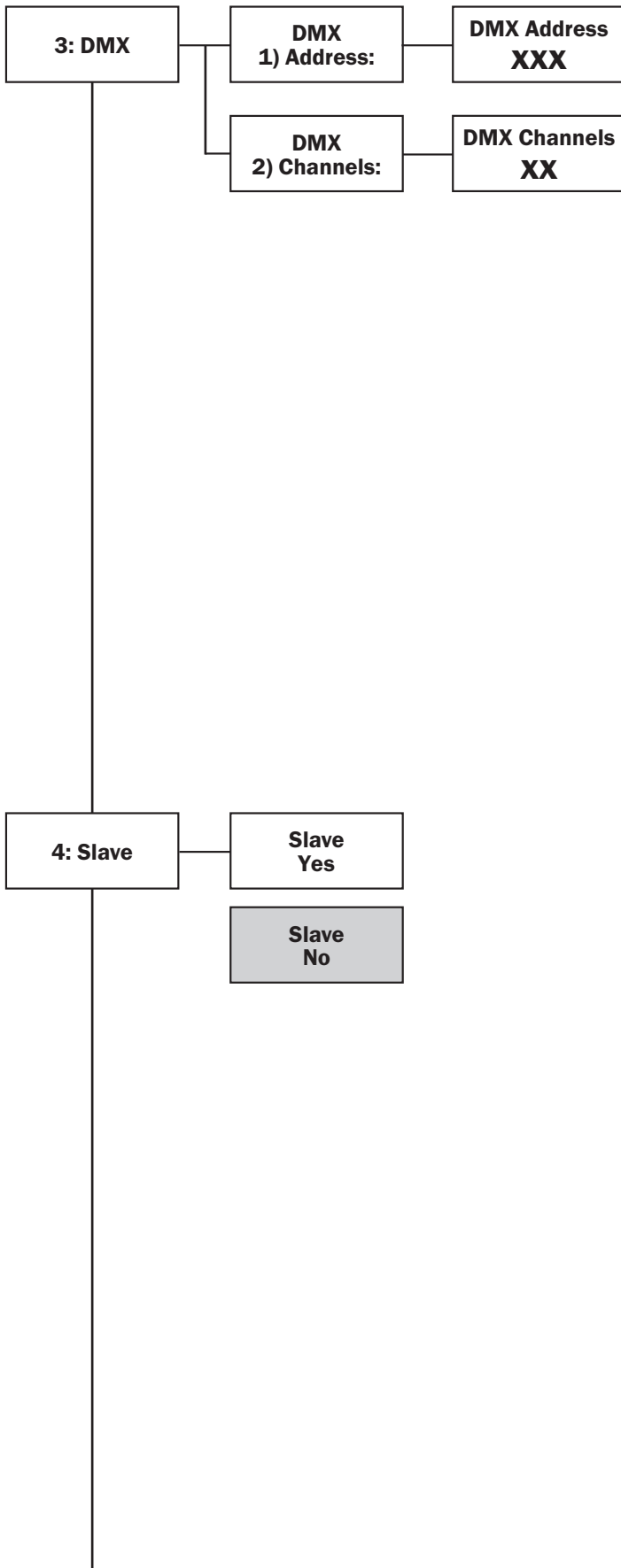

### DMX address:

To access the DMX address setting, press the “MODE” button until “3: DMX” is highlighted on the OLED display. Press the “SET” button and use the “UP” and “DOWN” buttons to highlight “1) Address”. Press the “SET” button and use the “UP” and “DOWN” buttons to select the DMX address required between 001-512. Press the “SET” button to confirm the setting.

### DMX channel:

To access DMX channel mode, press the “MODE” button until “3: DMX” is highlighted on the OLED display. Press the “SET” button and use the “UP” and “DOWN” buttons to highlight “2) Channels”. Press the “SET” button and use the “UP” and “DOWN” buttons to select the DMX channel required 01/04/04/07/09/18/20/23 or 27 selectable. Press the “SET” button to confirm the setting.

### Slave mode:

To access slave mode, press the “MODE” button until “4: Slave” is highlighted on the OLED display. Press the “SET” button and use the “UP” and “DOWN” buttons to select between “Yes” and “No”. Press the “SET” button to enter slave mode when yes is selected.

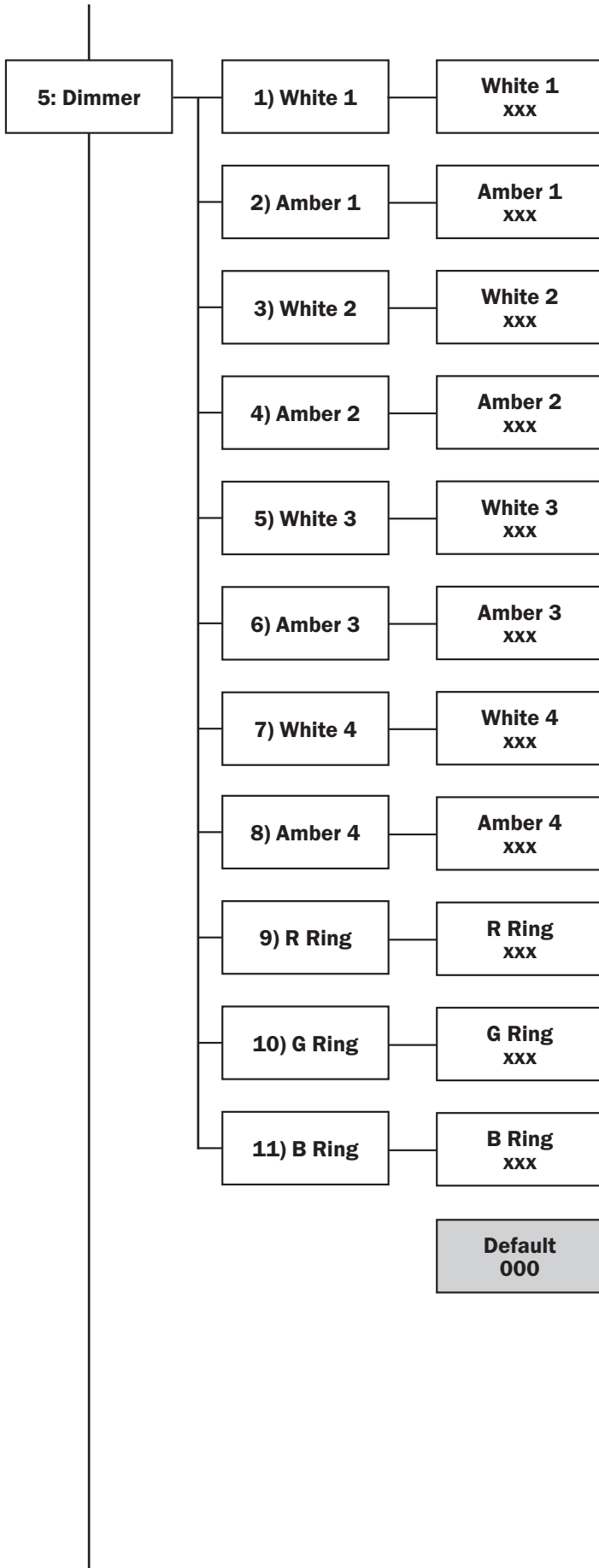

### Manual mode:

To access the manual dimming mode, press the “MODE” button until “5: Dimmer” is highlighted on the OLED display. Press the “SET” button and use the “UP” and “DOWN” buttons to select between White Pods 1-4, Amber Pods 1-4, Backlight R, Backlight G or Backlight B. Press the “SET” button and use the “UP” and “DOWN” buttons to adjust the brightness between 000-255.

Press the “SET” button to confirm the setting.

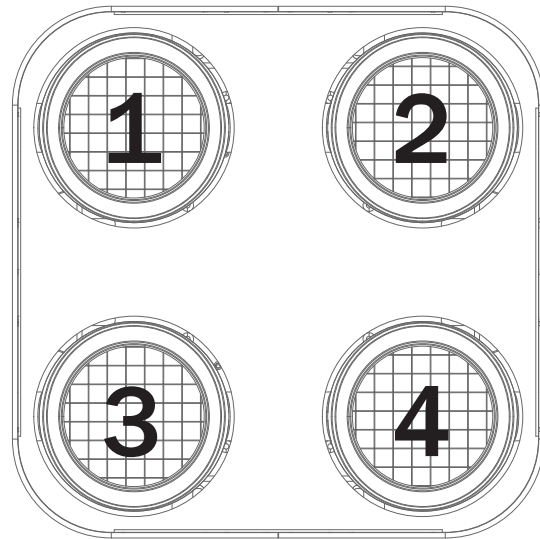

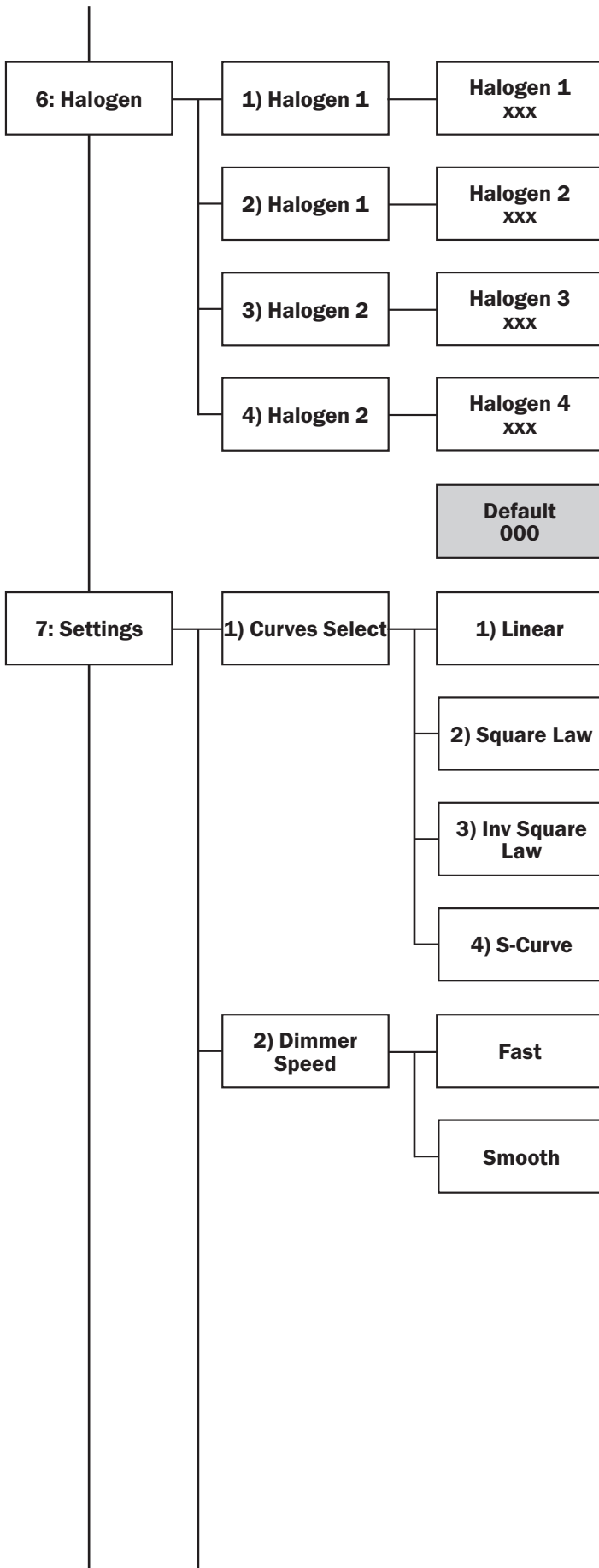

### Manual halogen mode:

To access the manual halogen dimming mode, press the “MODE” button until “6: Halogen” is highlighted on the OLED display. Press the “SET” button and use the “UP” and “DOWN” buttons to select between Pods 1-4. Press the “SET” button and use the “UP” and “DOWN” buttons to adjust the brightness between 000-255.

Press the “SET” button to confirm the setting.

### Dimming curve:

To access the dimming curve setting, press the “MODE” button until “7: Settings” is highlighted on the OLED display. Press the “SET” button and use the “UP” and “DOWN” buttons to select “1) Curves Select”. Press the “SET” button and use the “UP” and “DOWN” buttons to select between “Linear”, “Square Law”, “Inv Square Law” and “S-Curve”. Press the “SET” button to confirm the setting.

### Dimming speed:

To access the dimming speed setting, press the “MODE” button until “7: Settings” is highlighted on the OLED display. Press the “SET” button and use the “UP” and “DOWN” buttons to select “2) Dimmer Speed”. Press the “SET” button and use the “UP” and “DOWN” buttons to select between “Fast” (LED) or “Smooth” (Halogen). Press the “SET” button to confirm the setting.

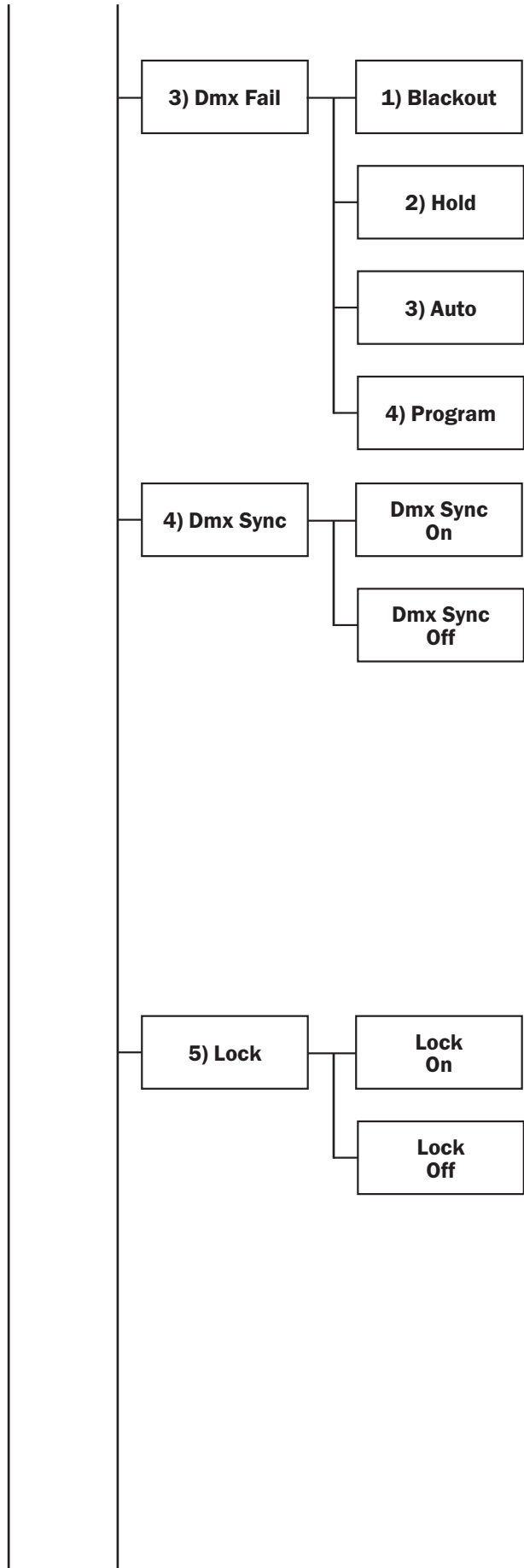

### DMX fail setting:

Sets what the fixture does when the DMX signal is lost. To access the DMX fail setting, press the “MODE” button until “7: Settings” is highlighted on the OLED display. Press the “SET” button and use the “UP” and “DOWN” buttons to select “3) Dmx Fail”. Press the “SET” button and use the “UP” and “DOWN” buttons to select between “Blackout”, “Hold”, “Auto” and “Program”. Press the “SET” button to confirm the setting.

### Dmx synchronisation:

To access the DMX sync setting, press the “MODE” button until “7: Settings” is highlighted on the OLED display. Press the “SET” button and use the “UP” and “DOWN” buttons to select “4) Dmx Sync”. Press the “SET” button and use the “UP” and “DOWN” buttons to select between “On” and “Off”. Press the “SET” button to enable Dmx sync when yes is selected.

Please note: The DMX Synchronisation setting should be set to on when using the built-in presets via DMX to ensure the fixtures stay synchronised.

### Display lock:

To access the display lock setting, press the “MODE” button until “7: Settings” is highlighted on the OLED display. Press the “SET” button and use the “UP” and “DOWN” buttons to select “5) Lock”. Press the “SET” button and use the “UP” and “DOWN” buttons to select between “On” and “Off”. Press the “SET” button to enable Display Lock when yes is selected.

Please note: After 30 seconds of inactivity the display will lock. To unlock the menu hold the “MODE” and “SET” buttons for 3 seconds.

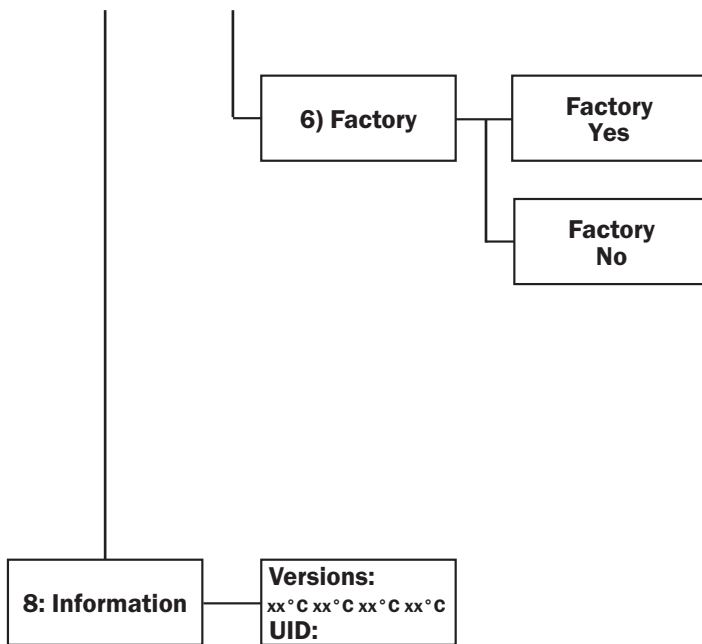

### Factory reset:

Resets all the fixtures factory settings.

To access the factory setting reset, press the “**MODE**” button until “**7: Settings**” is highlighted on the OLED display. Press the “**SET**” button and use the “**UP**” and “**DOWN**” buttons to select “**6) Factory**”. Press the “**SET**” button and use the “**UP**” and “**DOWN**” buttons to select between “**Yes**” and “**No**”. Press the “**SET**” button to perform the factory reset when yes is selected.

### Fixture information:

Displays the fixtures version, each pods temperature and RDM ID.

To display the fixture information, press the “**MODE**” button until “**8: Information**” is highlighted on the OLED display. Press the “**SET**” button and the fixtures version, each pods temperature and RDM ID will be displayed.

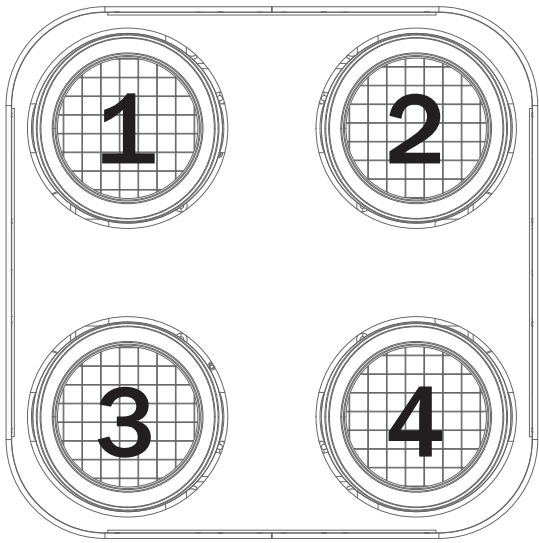

### 7 channel mode:

Channel	Value	Function
CH1	000-255	Pod 1 halogen dimmer 0-100%
CH2	000-255	Pod 2 halogen dimmer 0-100%
CH3	000-255	Pod 3 halogen dimmer 0-100%
CH4	000-255	Pod 4 halogen dimmer 0-100%
CH5	000-255	Red backlight dimmer 0-100%
CH6	000-255	Green backlight dimmer 0-100%
CH7	000-255	Blue backlight dimmer 0-100%

### 1 channel mode:

Channel	Value	Function
CH1	000-255	Halogen dimmer 0-100%

### 4 channel mode 1:

Channel	Value	Function
CH1	000-255	Halogen dimmer 0-100%
CH2	000-255	Red backlight dimmer 0-100%
CH3	000-255	Green backlight dimmer 0-100%
CH4	000-255	Blue backlight dimmer 0-100%

### 4 channel mode 2:

Channel	Value	Function
CH1	000-255	Pod 1 Halogen dimmer 0-100%
CH2	000-255	Pod 2 Halogen dimmer 0-100%
CH3	000-255	Pod 3 Halogen dimmer 0-100%
CH4	000-255	Pod 4 Halogen dimmer 0-100%

### 9 channel mode:

Channel	Value	Function
CH1	000-255	Halogen master dimmer 0-100%
CH2	000-255	Pod 1 halogen dimmer 0-100%
CH3	000-255	Pod 2 halogen dimmer 0-100%
CH4	000-255	Pod 3 halogen dimmer 0-100%
CH5	000-255	Pod 4 halogen dimmer 0-100%
CH6	000-255	Backlight master dimmer 0-100%
CH7	000-255	Red backlight dimmer 0-100%
CH8	000-255	Green backlight dimmer 0-100%
CH9	000-255	Blue backlight dimmer 0-100%

### 18 channel mode:

Channel	Value	Function
CH1	000-255	Halogen master dimmer 0-100%
CH2	000-255	Pod 1 halogen dimmer 0-100%
CH3	000-255	Pod 2 halogen dimmer 0-100%
CH4	000-255	Pod 3 halogen dimmer 0-100%
CH5	000-255	Pod 4 halogen dimmer 0-100%
CH6	000-255	Backlight master dimmer 0-100%
CH7	000-255	Pod 1 red backlight dimmer 0-100%
CH8	000-255	Pod 1 green backlight dimmer 0-100%
CH9	000-255	Pod 1 blue backlight dimmer 0-100%
CH10	000-255	Pod 2 red backlight dimmer 0-100%
CH11	000-255	Pod 2 green backlight dimmer 0-100%
CH12	000-255	Pod 2 blue backlight dimmer 0-100%
CH13	000-255	Pod 3 red backlight dimmer 0-100%
CH14	000-255	Pod 3 green backlight dimmer 0-100%
CH15	000-255	Pod 3 blue backlight dimmer 0-100%
CH16	000-255	Pod 4 red backlight dimmer 0-100%
CH17	000-255	Pod 4 green backlight dimmer 0-100%
CH18	000-255	Pod 4 blue backlight dimmer 0-100%

### 20 channel mode:

Channel	Value	Function
CH1	000-255	Pod 1 warm white dimmer 0-100%
CH2	000-255	Pod 1 amber dimmer 0-100%
CH3	000-255	Pod 2 warm white dimmer 0-100%
CH4	000-255	Pod 2 amber dimmer 0-100%
CH5	000-255	Pod 3 warm white dimmer 0-100%
CH6	000-255	Pod 3 amber dimmer 0-100%
CH7	000-255	Pod 4 warm white dimmer 0-100%
CH8	000-255	Pod 4 amber dimmer 0-100%
CH9	000-255	Pod 1 red backlight dimmer 0-100%
CH10	000-255	Pod 1 green backlight dimmer 0-100%
CH11	000-255	Pod 1 blue backlight dimmer 0-100%
CH12	000-255	Pod 2 red backlight dimmer 0-100%
CH13	000-255	Pod 2 green backlight dimmer 0-100%
CH14	000-255	Pod 2 blue backlight dimmer 0-100%
CH15	000-255	Pod 3 red backlight dimmer 0-100%
CH16	000-255	Pod 3 green backlight dimmer 0-100%
CH17	000-255	Pod 3 blue backlight dimmer 0-100%
CH18	000-255	Pod 4 red backlight dimmer 0-100%
CH19	000-255	Pod 4 green backlight dimmer 0-100%
CH20	000-255	Pod 4 blue backlight dimmer 0-100%

### 23 channel mode:

Channel	Value	Function
CH1	000-255	Master dimmer 0-100%
CH2	000-010	No function
	011-255	Strobe (slow-fast)
CH3	000-255	Pod 1 warm white dimmer 0-100%
CH4	000-255	Pod 1 amber dimmer 0-100%
CH5	000-255	Pod 2 warm white dimmer 0-100%
CH6	000-255	Pod 2 amber dimmer 0-100%
CH7	000-255	Pod 3 warm white dimmer 0-100%
CH8	000-255	Pod 3 amber dimmer 0-100%
CH9	000-255	Pod 4 warm white dimmer 0-100%
CH10	000-255	Pod 4 amber dimmer 0-100%
CH11	000-255	Backlight master dimmer 0-100%
CH12	000-255	Pod 1 red backlight dimmer 0-100%
CH13	000-255	Pod 1 green backlight dimmer 0-100%
CH14	000-255	Pod 1 blue backlight dimmer 0-100%
CH15	000-255	Pod 2 red backlight dimmer 0-100%
CH16	000-255	Pod 2 green backlight dimmer 0-100%
CH17	000-255	Pod 2 blue backlight dimmer 0-100%
CH18	000-255	Pod 3 red backlight dimmer 0-100%
CH19	000-255	Pod 3 green backlight dimmer 0-100%
CH20	000-255	Pod 3 blue backlight dimmer 0-100%
CH21	000-255	Pod 4 red backlight dimmer 0-100%
CH22	000-255	Pod 4 green backlight dimmer 0-100%
CH23	000-255	Pod 4 blue backlight dimmer 0-100%



## 27 channel mode:

Channel	Value	Function
CH1	000-255	Master dimmer 0-100%
CH2	000-010	No function
	011-255	Strobe (slow-fast)
CH3	000-010	No function
	011-255	Random strobe (slow-fast)
CH4	000-010	No function
	011-021	All pods - Warm white
	022-032	All pods - Amber
	033-043	Pod 1 & 3 - Warm white Pod 2 & 4 - Amber
	044-054	Pod 1 & 3 - Amber Pod 2 & 4 - Warm white
	055-065	Pod 1 & 2 - Warm white Pod 3 & 4 - Amber
	066-076	Pod 1 & 2 - Amber Pod 3 & 4 - Warm white
	077-087	All pods - Warm white & Amber
	088-098	All pods - Red
	099-109	All pods - Green
	110-120	All pods - Blue
	121-131	All pods - Orange
	132-142	All pods - Medium Yellow
	143-153	All pods - Yellow
	154-164	All pods - Magenta
	165-175	All pods - Hot Pink
	176-186	All pods - Cyan
	187-197	All pods - Coral
	198-208	All pods - Mint Green
	209-219	All pods - Lilac
220-230	All pods - Dark Yellow	
231-255	All pods - White (RGB)	
CH5	000-015	No function
	016-026	Program 2
	027-037	Program 3
	038-048	Program 4
	049-059	Program 5
	060-070	Program 6
	071-081	Program 7
	082-092	Program 8
	093-103	Program 9

Channel	Value	Function
CH5 (cont.)	104-114	Program 10
	115-125	Program 11
	126-136	Program 12
	137-147	Program 13
	148-158	Program 14
	159-169	Program 15
	170-180	Program 16
	181-191	Program 17
	192-202	Program 18
	203-213	Program 19
	214-224	Program 20
225-235	Program 21	
236-246	Program 22	
247-255	Program 23	
CH6	000-255	Program speed (slow-fast)
CH7	000-255	Pod 1 warm white dimmer 0-100%
CH8	000-255	Pod 1 amber dimmer 0-100%
CH9	000-255	Pod 2 warm white dimmer 0-100%
CH10	000-255	Pod 2 amber dimmer 0-100%
CH11	000-255	Pod 3 warm white dimmer 0-100%
CH12	000-255	Pod 3 amber dimmer 0-100%
CH13	000-255	Pod 4 warm white dimmer 0-100%
CH14	000-255	Pod 4 amber dimmer 0-100%
CH15	000-255	Backlight master dimmer 0-100%
CH16	000-255	Pod 1 red backlight dimmer 0-100%
CH17	000-255	Pod 1 green backlight dimmer 0-100%
CH18	000-255	Pod 1 blue backlight dimmer 0-100%
CH19	000-255	Pod 2 red backlight dimmer 0-100%
CH20	000-255	Pod 2 green backlight dimmer 0-100%
CH21	000-255	Pod 2 blue backlight dimmer 0-100%
CH22	000-255	Pod 3 red backlight dimmer 0-100%

### 27 channel mode (cont.):

Channel	Value	Function
CH23	000-255	Pod 3 green backlight dimmer 0-100%
CH24	000-255	Pod 3 blue backlight dimmer 0-100%
CH25	000-255	Pod 4 red backlight dimmer 0-100%
CH26	000-255	Pod 4 green backlight dimmer 0-100%
CH27	000-255	Pod 4 blue backlight dimmer 0-100%

### Setting the DMX address:

The DMX mode enables the use of a universal DMX controller. Each fixture requires a “start address” from 1- 512. A fixture requiring one or more channels for control begins to read the data on the channel indicated by the start address. For example, a fixture that occupies or uses 7 channels of DMX and was addressed to start on DMX channel 100, would read data from channels: 100, 101, 102, 103, 104, 105 and 106. Choose a start address so that the channels used do not overlap. E.g. the next unit in the chain starts at 107.

### DMX 512:

DMX (Digital Multiplex) is a universal protocol used as a form of communication between intelligent fixtures and controllers. A DMX controller sends DMX data instructions from the controller to the fixture. DMX data is sent as serial data that travels from fixture to fixture via the DATA “IN” and DATA “OUT” XLR terminals located on all DMX fixtures (most controllers only have a data “out” terminal).

### DMX linking:

DMX is a language allowing all makes and models of different manufactures to be linked together and operate from a single controller, as long as all fixtures and the controller are DMX compliant. To ensure proper DMX data transmission, when using several DMX fixtures try to use the shortest cable path possible. The order in which fixtures are connected in a DMX line does not influence the DMX addressing. For example; a fixture assigned to a DMX address of 1 may be placed anywhere in a DMX line, at the beginning, at the end, or anywhere in the middle. When a fixture is assigned a DMX address of 1, the DMX controller knows to send DATA assigned to address 1 to that unit, no matter where it is located in the DMX chain.

### DATA cable (DMX cable) requirements (for DMX operation):

This fixture can be controlled via DMX-512 protocol. The DMX address is set on the back of the unit. Your unit requires either a standard 3-pin or 5-pin XLR connector for data input/output, see images below.



Further DMX cables can be purchased from all good sound and lighting suppliers or Prolight Concepts dealers.

Please quote:	3-Pin:	<b>CABL10 – 2m</b>	<b>CABL11 – 5m</b>	<b>CABL12 – 10m</b>
	5-Pin:	<b>CABL185 – 2m</b>	<b>CABL187 – 5m</b>	<b>CABL188 – 10m</b>

Also remember that DMX cable must be daisy chained and cannot be split.

**Notice:**

Be sure to follow the diagrams below when making your own cables. Do not connect the cables shield conductor to the ground lug or allow the shield conductor to come in contact with the XLRs outer casing. Grounding the shield could cause a short circuit and erratic behaviour.

Pin Configuration	
3-Pin	5-Pin
	Pin 1 - Ground
	Pin 2 - Negative
	Pin 3 - Positive
-	Pin 4 - N/C
-	Pin 5 - N/C

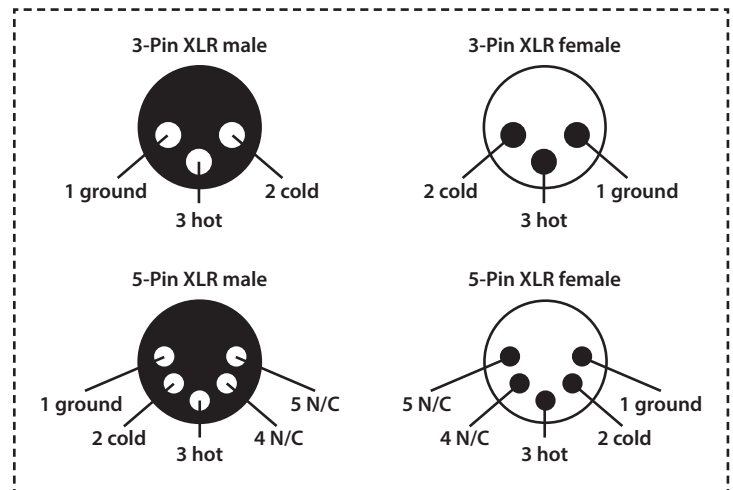
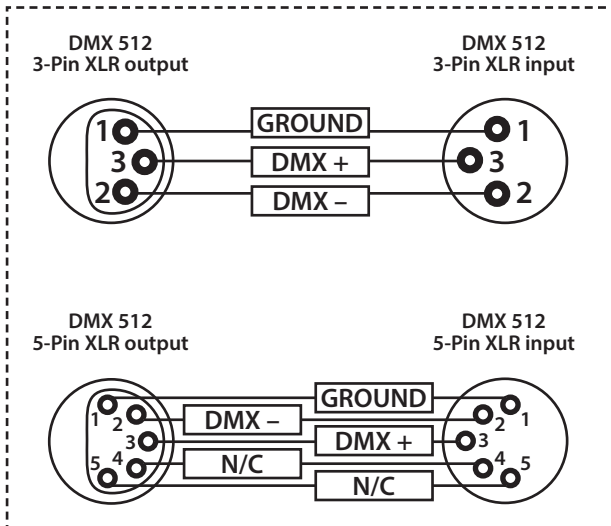

**Line termination:**

When longer runs of cable are used, you may need to use a terminator on the last unit to avoid erratic behaviour.

**Using a cable terminator will decrease the possibilities of erratic behaviour.**

(3-pin - Order ref: CABL90,  
5-pin - Order ref: CABL89)

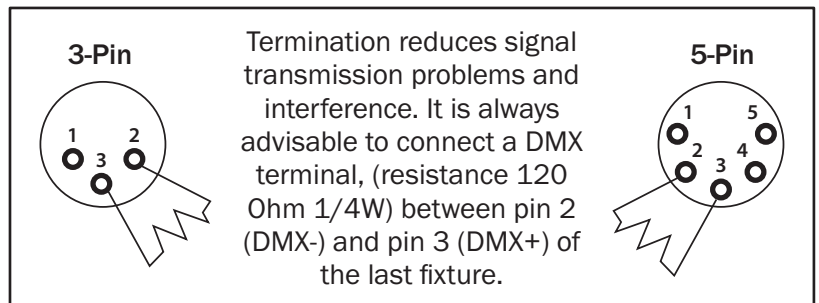

**5-pin XLR DMX connectors:**

Some manufactures use 5-pin XLR connectors for data transmission in place of 3-pin. 5-pin XLR fixtures may be implemented in a 3-pin XLR DMX line. When inserting standard 5-pin XLR connectors in to a 3-pin line a cable adaptor must be used. The diagram below details the correct cable conversion.

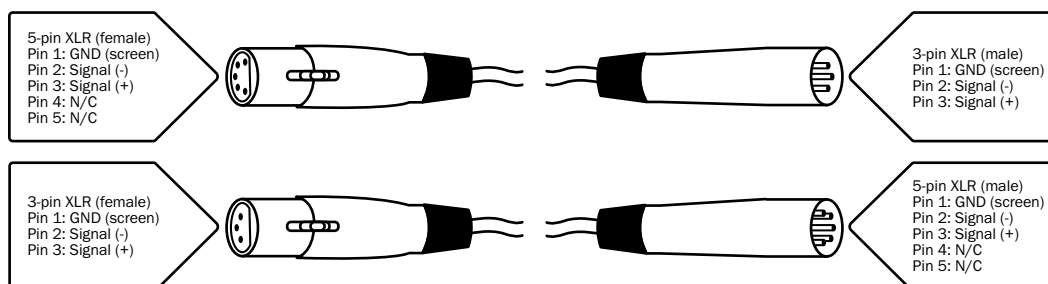

### Power linking:

This fixture provides power linking via the power output on the rear allowing multiple units to be connected together. The maximum number of fixtures that can be connected is 6 fixtures @ 240V or 3 fixtures @ 120V (including the first fixture). After the maximum number of fixtures are connected a new power run will need to be started.

Please note: Caution should be used when power linking other fixtures to the Fury 400 as the power consumption of other fixtures will vary. Fixtures fitted with lamps often require 2/3 times more current on startup, these may require their own power source.

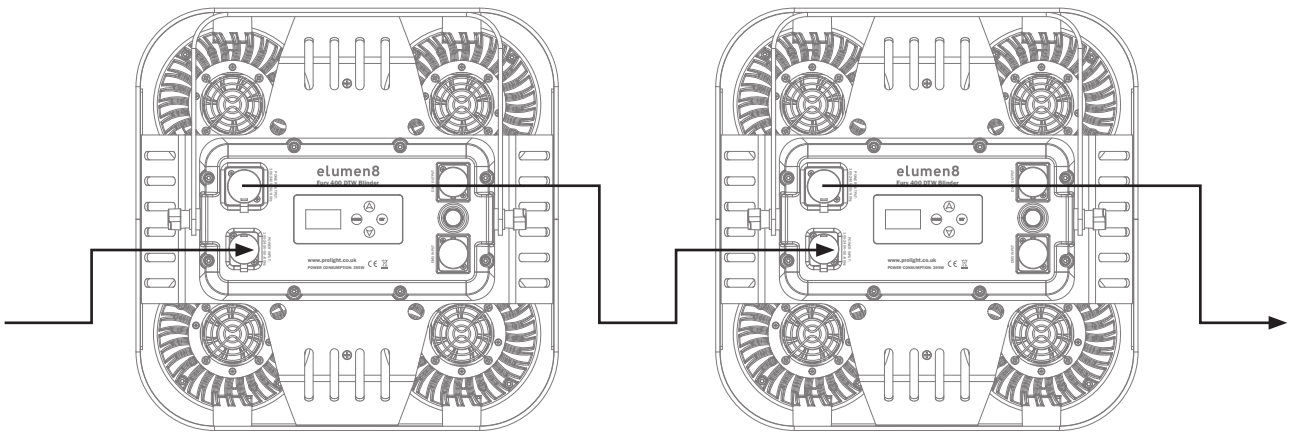



***Correct Disposal of this Product  
(Waste Electrical & Electronic Equipment)***

**(Applicable in the European Union and other European countries  
with separate collection systems)**

This marking shown on the product or its literature, indicates that it should not be disposed with other household wastes at the end of its working life. To prevent possible harm to the environment or human health from uncontrolled waste disposal, please separate this from other types of wastes and recycle it responsibly to promote the sustainable reuse of material resources.

Household users should contact either the retailer where they purchased this product, or their local government office, for details of where and how they can take this item for environmentally safe recycling.

Business users should contact their supplier and check the terms and conditions of the purchase contract. This product should not be mixed with other commercial wastes for disposal.





# elumen8