



0230-0356rC

PO BOX 4394
SANTA ROSA, CA
95402 USA

P (707) 525-9941
F (707) 575-7046
EMGPICKUPS.COM

INSTALLATION INFORMATION

EMG MODELS: **EMG-JIM ROOT DAEMONUM SET** (EMG-JR BRIDGE/ EMG-JR NECK)

SPECIFICATIONS:

	MODEL:	
	JR-N	JR-B
Logo Color*	Silver	Silver
Magnet Type **	C	C/S
Resonant Frequency (KHz)	1.80	1.63
Output Voltage (String)	3.00	3.00
Output Voltage (Strum)	8.0	8.0
Output Noise (60 Hz)	-120	-120
Output Impedance (Kohm)	3	3
Current @9V (Microamps)	340	340
Battery Life (Hours)	600	600
Maximum Supply (Volts DC)	27	27

*Note: Magnet Type: C (Ceramic) C/S (Ceramic/Steel)

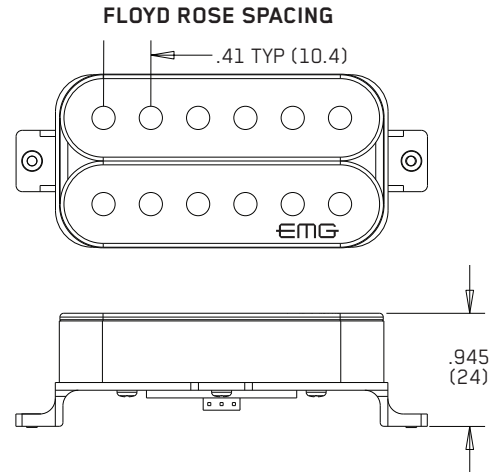
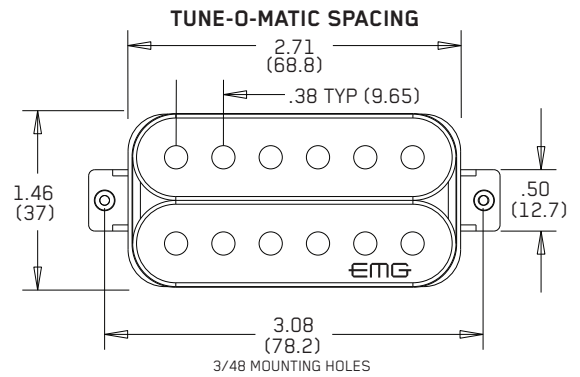

INSTALLATION NOTES:

All EMG Pickups are compatible with each other. EMG accessories, the VLPF, EXG, SPC or RPC Controls can be added to any EMG Pickup System without requiring an extra battery. DO NOT reconnect the bridge ground wire, EMG Pickups do not require string grounding. Use the 25K Ohm controls that are included for best results. If your output jack is a long panel style you will need a stereo jack, use a SwitchCraft 152B, soldering will be required (see the bottom of page 3). Adjust the pickup level to the strings, and at a distance that works for you, experiment. Alternate wiring diagrams are available at; emgpickups.com.

INCLUDED WITH EACH PICKUP SET:

2 VOLUME CONTROLS (25K)
2 TONE CONTROLS (25K)

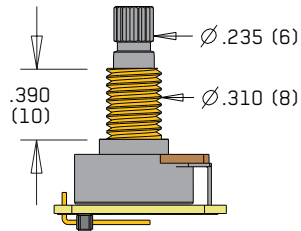

ADJUSTMENT
SCREWS & SPRINGS (2 pr)



2 PICKUP CABLE 15" (38cm)



4 CONNECT CABLES 5.5" (14cm)



OUTPUT CABLE 6" (15cm)



BATTERY CABLE 7" (18cm)



BATTERY
BUSS

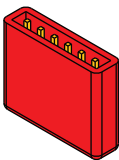

STEREO OUTPUT
JACK

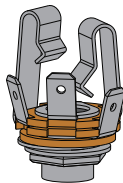

2 PICKUP IN/ OUT
BATTERY BUSS

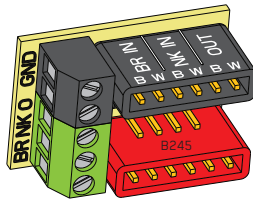

WARRANTY

All EMG Pickups and accessories are warranted for a period of two years. This warranty does not cover failure due to improper installation, abuse or damage. If upon examination the pickup is determined to be defective, a replacement will be made. Warranty replacement products are covered by this same warranty. This warranty covers only those pickups and accessories sold by authorized EMG Dealers. This warranty is not transferable.

Installation Instructions:

EMG Models: Jim Root Daemonum Set

General Notes:

Every attempt has been made to make this a solderless installation.

There are some instances where this is not possible;

- 1) If your instrument uses the long panel output jack and you had passive pickups you will need a new stereo output jack, the Switchcraft 152B is recommended. Soldering to the new jack will be required, see Diagram 5c.
- 2) Some instruments may already have a battery holder installed and in that case see the diagram at the bottom of page 4.
- 3) Instruments with two pickups may need soldering to the selection switch in some installations.

Installation (Two Pickup Guitars with Selection switch):

Guitars with two pickups and a selection switch will use the EMG B245 Pickup Buss as shown in Diagram #2.

The Pickup Buss is a convenient way to wire your guitar without soldering.

There is a separate sheet attached to these instructions that describes the B245 Pickup Buss in detail.

In all installations it's best to find a place to mount the Pickup Buss in the control cavity before starting. Then, after the cables are routed use the velcro to mount it securely.

2 Pickups / Toggle Select Switch / Master Volume and Tone

Refer to Diagrams #1, #2, and #3

- 1) Install the Pickups and route the Pickup cables to the control cavity.
If the cables are too long, wind up the excess and keep it under the pickup.
- 2) Mount the Volume and Tone controls into the body.
Plug both Pickup cables onto the B245 Pickup Buss (BLACK Shroud) as shown, Refer to diagram #2
Bridge Pickup to position 1
Neck Pickup to position 2
- 3) Plug a connect cable from the Pickup Buss (position 3) to the Master Volume control as shown in diagram #3.
- 4) Plug a connect cable from the Master Volume to the Master Tone as shown.
- 5) Strip the insulation from the switch wires and Insert them into the GREEN Terminal Block and tighten the screws with a small screwdriver.
The Bridge pickup goes to the BR Terminal
The Neck pickup goes to the NK Terminal
The Output of the switch goes to the O Terminal
If there is a ground wire coming from the switch, insert it into one of the black terminals on the terminal block
If using the EMG solderless 3 way toggle refer to Diagram #5a. If using a hardwired 3 way blade or lever switch see Diagram #5b.
- 6) Plug the output cable onto the Master Tone control and connect the output wires to the output jack by pushing the connectors on as shown.
WHITE wire onto the TIP (T) contact,
BLACK wire onto the SLEEVE (S) contact
BLACK Battery Negative wire onto the RING (R) contact.

****Tips and Tricks**** Start your installation by:

- 1) Determine which type output jack your instrument has.
A Stereo 12B type is Included, but if you have a long panel jack a SwitchCraft 152B Long Panel Jack will be required.
- 2) Remove the strings, remove any existing Pickups and controls (remember the order and function of each control)
- 3) Determine a good spot for the Pickup Buss and make sure the cable or wires from the selection switch will reach the Pickup Buss,
- 4) Install the EMG Volume and Tone Controls and tighten them in.
- 5) Then install the pickups keeping any excess cable under the pickup rather than in the control cavity.
- 6) IMPORTANT: EMG Active pickups do not require a string ground wire! DO NOT Reconnect the string ground, it is unnecessary.

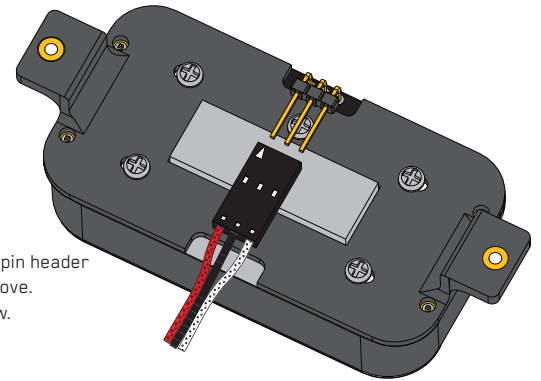

Diagram #1

Insert the plug onto the 3 pin header of the pickup as shown above.
Note the orientation arrow.

- 7) Plug the RED Wires of the pickups onto the V+ Buss (RED Shroud) along with the RED of the battery clip.
Extra pins on the V+ Buss are for EMG Accessories.
- 8) Put the battery in the insulating foam piece and place it securely in the control cavity.
We suggest that you plug in the instrument and test it before closing the control cavity.

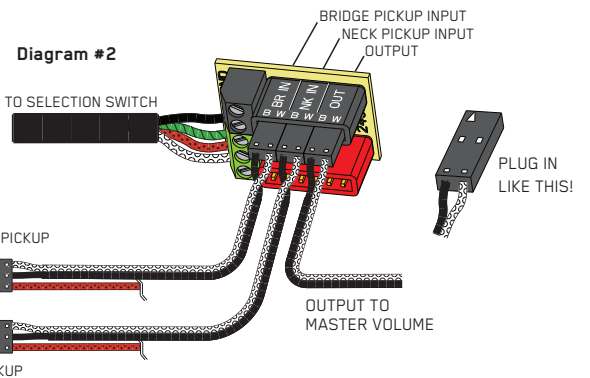
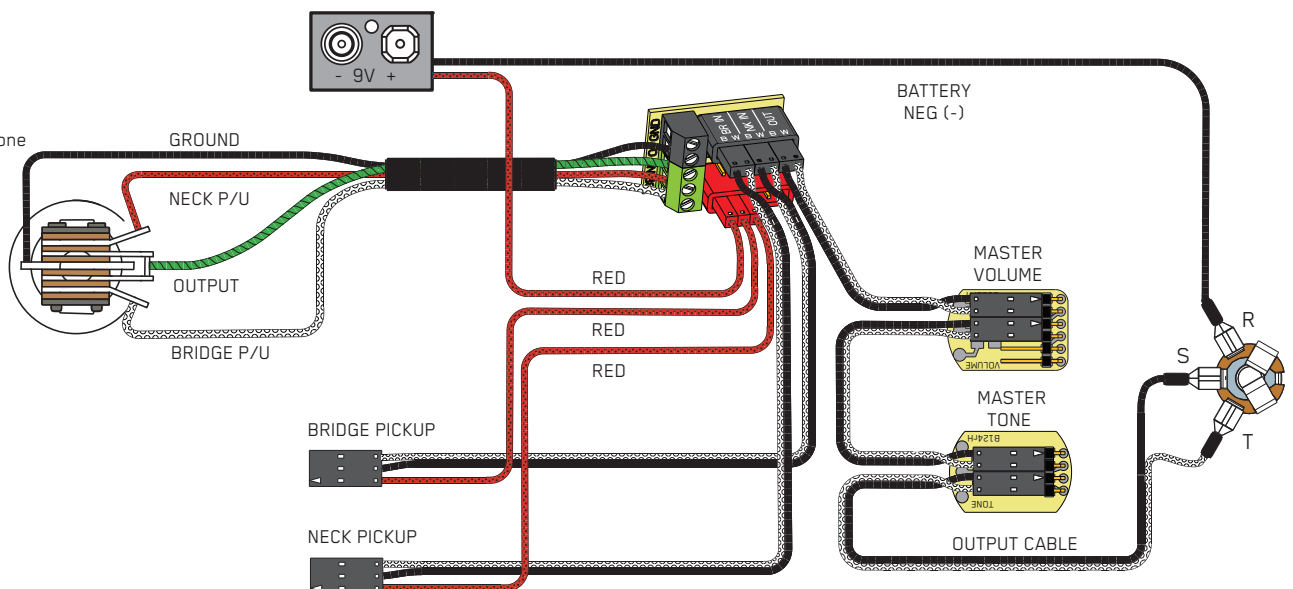

Diagram #2

Diagram #3

2 Pickups
Toggle Style Select Switch
Master Volume & Master Tone



2 Pickups / Toggle Select Switch / 2 Volumes and Master Tone

Refer to Diagram #4

- 1) Install the Pickups and route the Pickup cables to the control cavity.
If the cables are too long, wind up the excess and keep it under the pickup.
- 2) Mount the Volume and Tone controls into the body.
Plug both pickup cables onto the Volume controls as shown.
Plug a connect cable from the Bridge Volume control to the Pickup Buss (Position 1)
Plug a connect cable from the Neck Volume control to the Pickup Buss (Position 2)
- 3) Plug a connect cable from the Pickup Buss (position 3) to the Master Tone control as shown.
- 4) Strip the insulation from the switch wires and Insert them into the GREEN Terminal Block and tighten the screws with a small screwdriver.
The Bridge pickup goes to the BR Terminal
The Neck Pickup goes to the NK Terminal
The Output of the switch goes to the O Terminal
If there is a ground wire coming from the switch, insert it into one of the black terminals on the terminal block.
- 5) Plug the output cable onto the Tone control and connect the wires to the output jack by pushing the connectors on as shown.
WHITE wire onto the TIP (T) contact,
BLACK wire onto the SLEEVE (S) contact
BLACK Battery Negative wire onto the RING (R) contact.
- 6) Plug the RED Wires of the pickups onto the V+ Supply Buss (RED Shroud) along with the RED of the battery clip. Extra pins are for EMG Accessories.
- 7) Put the battery in the insulating foam and place it securely in the control cavity.
We suggest that you plug in the instrument and test it before closing the control cavity.

Diagram #4

2 Pickups

Toggle Style Switch

Volume each Pickup (Volumes are independent)

Master Tone

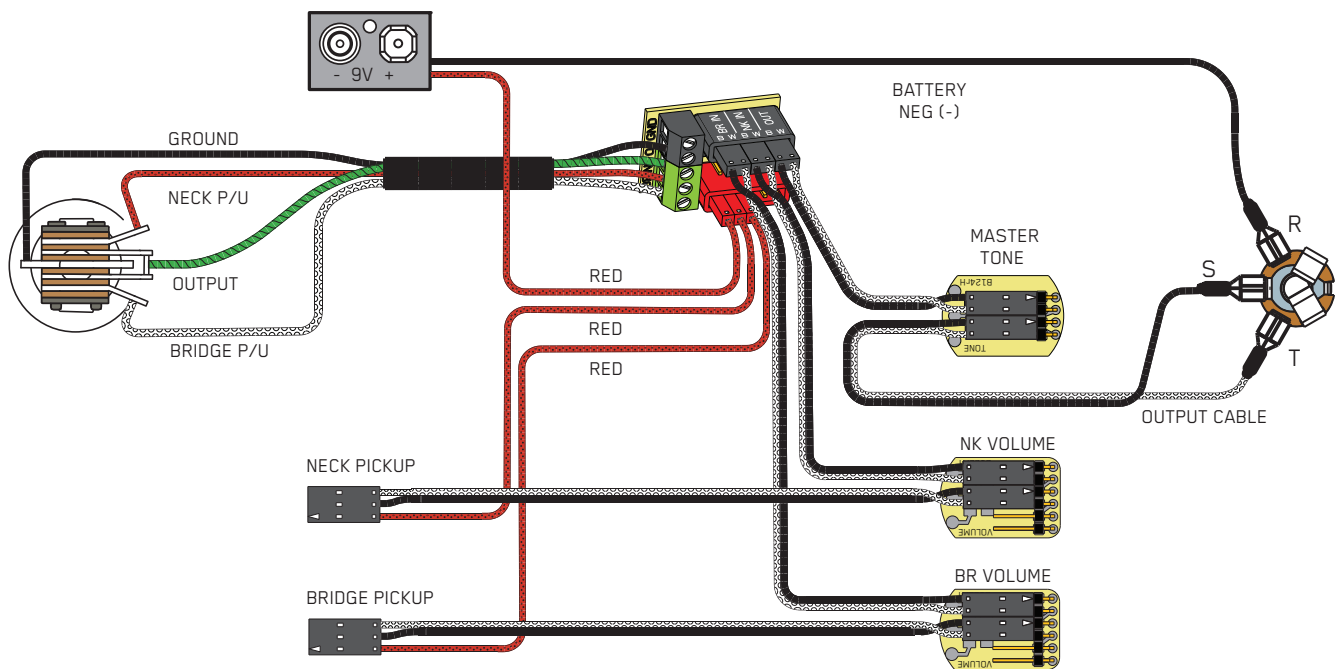

Diagram #5a

Connecting to the B289 3 Way Toggle:

Install the 4 pin Connector housing on the switch as shown in the diagram below. Install both of the 2 pin connectors on to the 4 pin connector between the black and red housings as shown. The black and green terminal blocks will not be used for the switch.

For more details you can refer to the B289 Instructions.

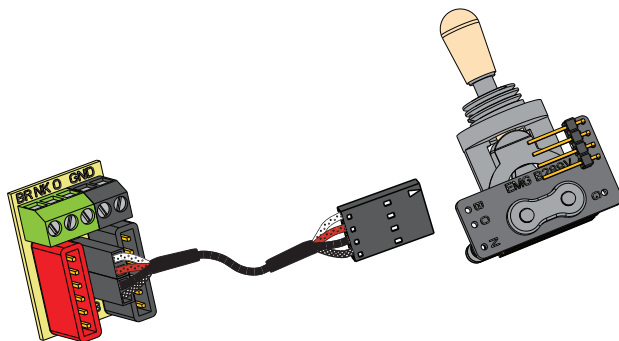

Diagram #5b

2 Pickups

Lever Style Select Switch

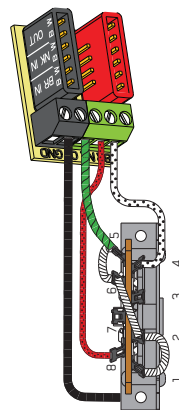
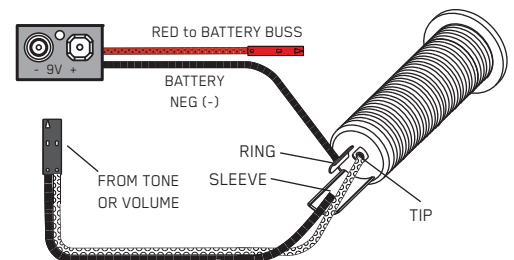

Diagram #5c

Soldering to the 152B Panel Jack:

If your instrument has a long Panel Jack like the one below you will have to solder the output cable as shown. Ground (Black) to the sleeve
Signal (White) to the Tip
Battery Negative (Black) to the Ring



2 Pickups / Toggle Select Switch / 2 Volumes and 2 Tones)

Refer to Diagram #6

- 1) Install the Pickups and route the cables to the control cavity.
If the cables are too long, wind up the excess and keep it under the pickup.
 - 2) Mount the Volume and Tone controls into the body
Plug both Neck and Bridge pickup cables onto the Volume Controls as shown.
Plug a connect cable from the Bridge (BR) Volume control to the Pickup Bus (Position 1). See Diagram #6
Plug a connect cable from the Neck (NK) Volume control to the Pickup Bus (Position 2). See Diagram #6
 - 3) Plug a connect cable from the Bridge (BR) Volume control to the Bridge (BR) Tone control as shown.
 - 4) Plug a connect cable from the Neck (NK) Volume control to the Neck (NK) Tone control as shown.
 - 5) Strip the insulation from the switch wires and Insert them into the GREEN Terminal Block and tighten the screws with a small screwdriver.
The Bridge pickup goes to the BR Terminal
The Neck Pickup goes to the NK Terminal
The Output of the switch goes to the O Terminal
If there is a ground wire coming from the switch, insert it into one of the black terminals on the terminal block.
 - 6) Plug the output cable onto the Pickup Bus (Position 3) and push the connectors onto the jack as shown.
WHITE wire onto the TIP (T) contact,
BLACK wire onto the SLEEVE (S) contact,
BLACK Battery Negative wire onto the RING (R) contact.
 - 7) Plug the RED Wires of the pickups onto the V+ Supply Buss (RED Shroud) along with the RED of the battery clip. Extra pins are for EMG Accessories.
 - 8) Put the battery in the foam insulator and place it securely in the control cavity.
- We suggest that you plug in the instrument and test it before closing the control cavity.

Diagram #6

2 Pickups
2 Volume (either volume will act as a master)
2 Tone
Toggle Style Switch

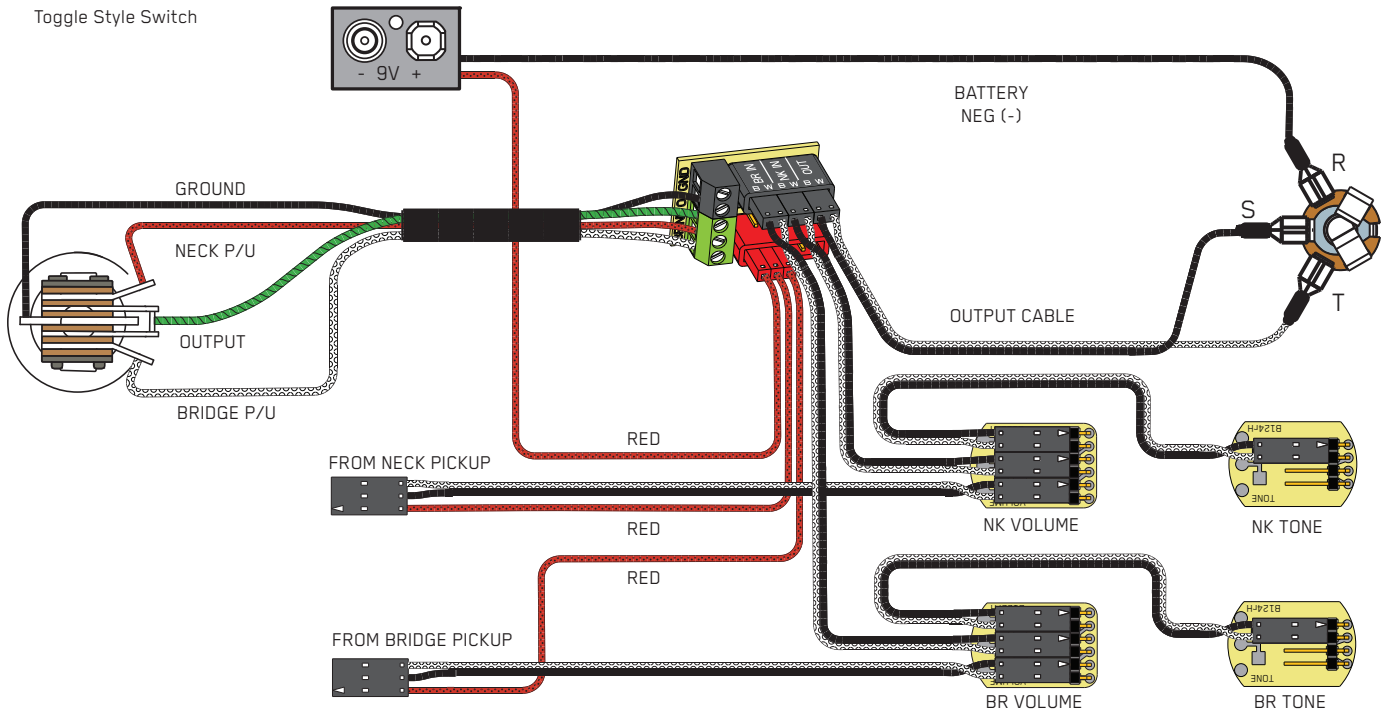

If the instrument has a Battery Holder:

If your instrument has a 9 or 18 Volt battery holder you can still use the EMG Connectors to supply power to the pickups. Simply cut and strip the wires from the battery clip provided. Twist the wires together and use the shrink tubing included to cover the connections. Soldering the wires is the preferred.

