

 **SENNHEISER**



**evolution**wireless 

# 100-P Series

Instruction manual  
Istruzioni per l'uso  
Gebruiksaanwijzing  
Руководство по эксплуатации

Bedienungsanleitung  
Notice d'emploi  
Instrucciones de uso  
Manual de instruções  
用法説明

# Contents

- Important safety instructions ..... 2
- The ew 100 G3 evolution wireless series ..... 3
  - The frequency bank system ..... 3
- Product overviews ..... 4
  - Overview of the EK 100 G3 diversity receiver ..... 4
  - Overview of the SK 100 G3 bodypack transmitter ..... 5
  - Overview of the SKM 100 G3 radio microphone ..... 6
  - Overview of the SKP 100 G3 plug-on transmitter ..... 7
  - Overview of the displays of the EK 100 G3 ..... 8
  - Overview of the displays of the SK 100/SKM 100/SKP 100 G3 ..... 9
- Putting the devices into operation ..... 10
  - EK 100 G3 diversity receiver ..... 10
  - SK 100 G3 bodypack transmitter ..... 12
  - SKM 100 G3 radio microphone ..... 13
  - SKP 100 G3 plug-on transmitter ..... 15
- Using the devices ..... 16
  - Switching the devices on/off ..... 17
  - Synchronizing a transmitter with the diversity receiver ..... 19
  - Deactivating the lock mode temporarily ..... 20
  - Muting the audio signal or deactivating the RF signal ..... 21
  - Selecting a standard display ..... 22
- Overview of the operating menus ..... 23
- Synchronizing transmitters with diversity receivers ..... 26
- Cleaning the devices ..... 28
- If a problem occurs ... ..... 29
- Specifications ..... 31
- Manufacturer Declarations ..... 34



Detailed instruction manuals for the individual products can be found on the corresponding product pages at [www.sennheiser.com](http://www.sennheiser.com).

## Important safety instructions

- Read this instruction manual.
- Keep this instruction manual. Always include this instruction manual when passing the products on to third parties.
- Heed all warnings and follow all instructions in this instruction manual.
- Use only a cloth for cleaning the products.
- Do not place the products near any heat sources such as radiators, stoves, or other devices (including amplifiers) that produce heat.
- Only use attachments/accessories specified by Sennheiser.
- When replacement parts are required, only use replacement parts specified by Sennheiser or those having the same characteristics as the original part. Unauthorized substitutions may result in fire, electric shock, or other hazards.
- Refer all servicing to qualified service personnel.  
Servicing is required if the products have been damaged in any way, liquid has been spilled, objects have fallen inside, the products have been exposed to rain or moisture, do not operate properly or have been dropped.
- **WARNING:** To reduce the risk of fire or electric shock, do not use the products near water and do not expose them to rain or moisture.

### Intended use

Intended use of the ew 100 G3 products devices includes:

- having read these instructions especially the chapter “Important safety instructions”,
- using the products within the operating conditions and limitations described in this instruction manual.

“Improper use” means using the products other than as described in these instructions, or under operating conditions which differ from those described herein.

## The ew 100 G3 evolution wireless series

With the ew 100 G3 evolution wireless series, Sennheiser offers high-quality state-of-the-art RF transmission systems with a high level of operational reliability and ease of use. Transmitters and receivers permit wireless transmission with studio-quality sound.

### Adaptive diversity

The EK 100 G3 diversity receiver operates on the **adaptive diversity** principle where the shield of the line cable is used as the second antenna to provide improved reception.

### The frequency bank system

The devices are available in 6 UHF frequency ranges with 1,680 frequencies per frequency range:

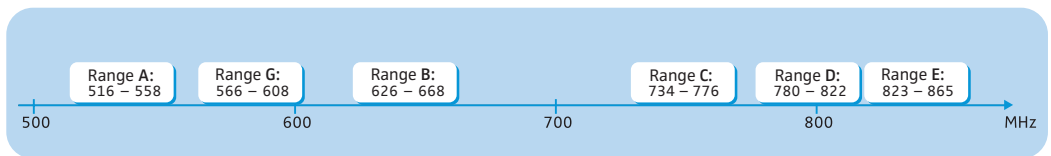

Each frequency range (A–E, G) offers 21 frequency banks with up to 12 channels each:

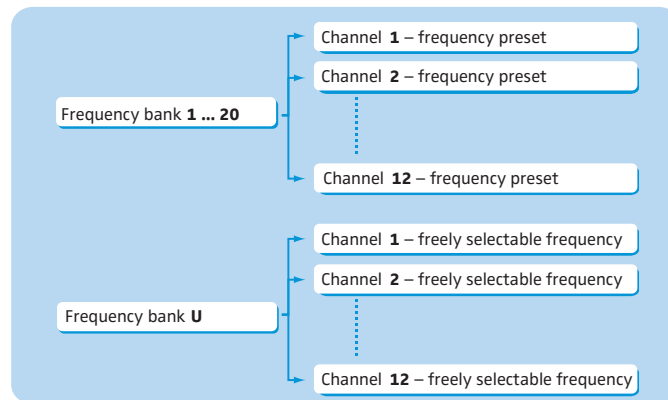

Each of the channels in the frequency banks “1” to “20” has been factory-preset to a fixed frequency (frequency preset).

The factory-preset frequencies within one frequency bank are intermodulation-free. These frequencies cannot be changed.

For an overview of the frequency presets, please refer to the supplied frequency information sheet. Updated versions of the frequency information sheet can be downloaded from the corresponding product page on our website at [www.sennheiser.com](http://www.sennheiser.com).

The frequency bank “U” allows you to freely select and store frequencies. It might be that these frequencies are **not** intermodulation-free.

## Product overviews

### Overview of the EK 100 G3 diversity receiver

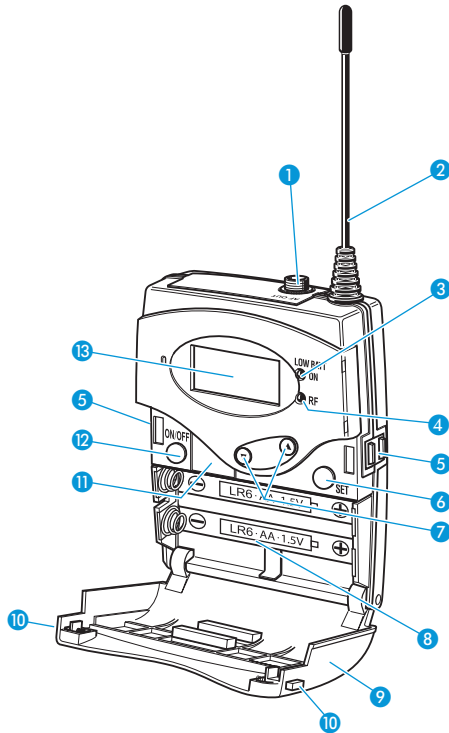

#### Operating elements

- 1 3.5 mm jack socket, lockable (AF OUT)  
(the shielding is used by antenna II)
- 2 Antenna I
- 3 Operation and battery status indicator,  
red LED  
(lit = ON/flashing = LOW BATTERY)
- 4 RF signal indication, green LED  
(lit = RF)
- 5 Charging contacts
- 6 SET button
- 7 ▲/▼ rocker button (UP/DOWN)
- 8 Battery compartment
- 9 Battery compartment cover
- 10 Battery compartment catches
- 11 Infra-red interface
- 12 ON/OFF button  
(serves as the ESC (cancel) key in  
the operating menu)
- 13 Display panel, backlit in orange

## Overview of the SK 100 G3 bodypack transmitter

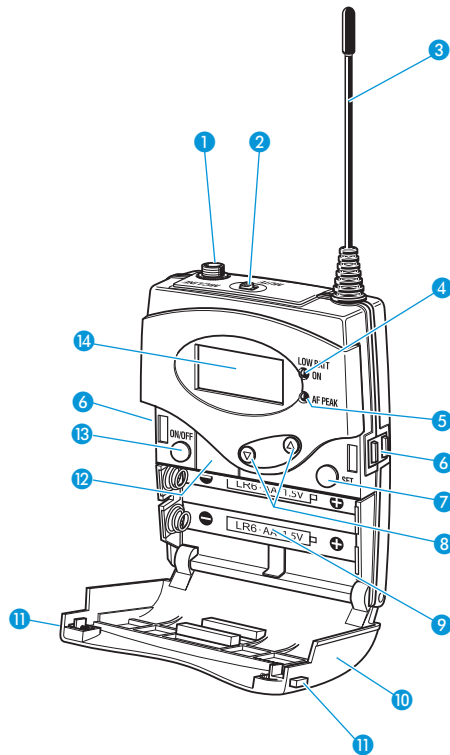

### Operating elements

- ① Microphone/instrument input (**MIC/LINE**), 3.5 mm jack socket, lockable
- ② **MUTE** switch
- ③ Antenna
- ④ Operation and battery status indicator, red LED  
(lit = **ON**/flashing = **LOW BATTERY**)
- ⑤ Audio overmodulation indicator, yellow LED  
(lit = **AF PEAK**)
- ⑥ Charging contacts
- ⑦ **SET** button
- ⑧ ▲/▼ rocker button (**UP/DOWN**)
- ⑨ Battery compartment
- ⑩ Battery compartment cover
- ⑪ Battery compartment catches
- ⑫ Infra-red interface
- ⑬ **ON/OFF** button, serves as the **ESC** (cancel) key in the operating menu
- ⑭ Display panel, backlit in orange

## Overview of the SKM 100 G3 radio microphone

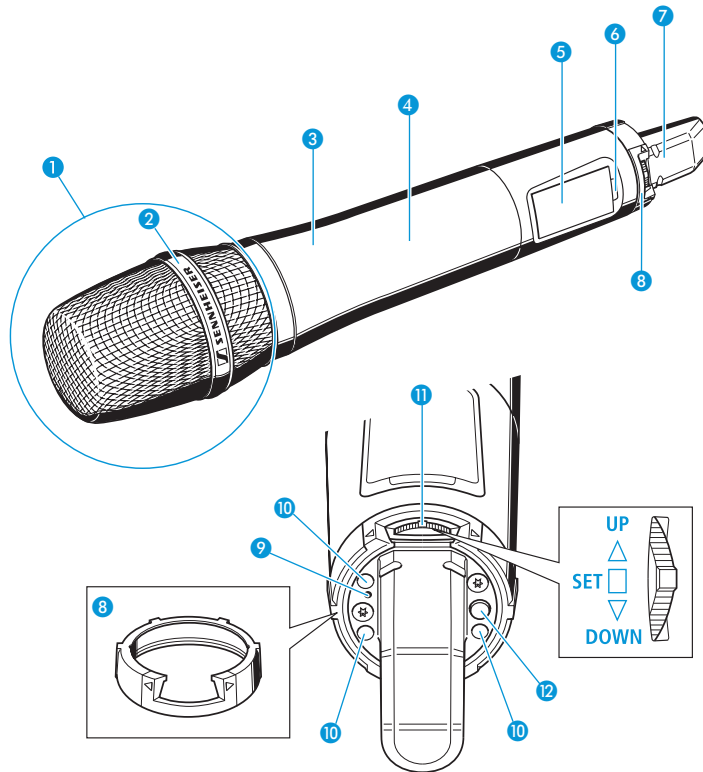

### Operating elements

- ① Microphone head (interchangeable)
- ② Name and pick-up pattern of the microphone head (not visible here)
- ③ Body of radio microphone
- ④ Battery compartment (not visible from outside)
- ⑤ Display panel, backlit in orange
- ⑥ Infra-red interface
- ⑦ Antenna
- ⑧ Color-coded protection ring; available in different colors
- ⑨ Operation and battery status indicator, red LED  
(lit = ON/flashing = LOW BATTERY)
- ⑩ Charging contacts
- ⑪ Multi-function switch:  
▼ (DOWN), ▲ (UP) and ■ (SET)
- ⑫ ON/OFF button, serves as the ESC (cancel) key in the operating menu

## Overview of the SKP 100 G3 plug-on transmitter

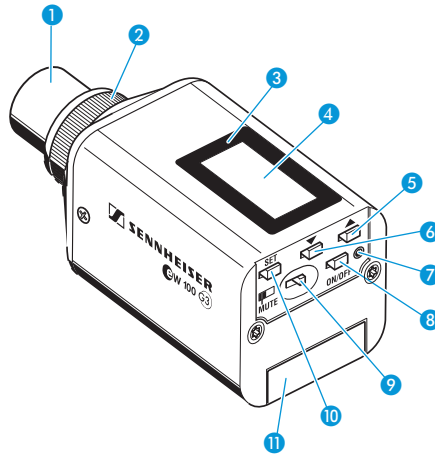

### Operating elements

- ① Microphone input, XLR-3 socket (female, unbalanced)
- ② Mechanical locking ring of XLR-3 socket
- ③ Infra-red interface
- ④ Display panel, backlit in orange
- ⑤ UP button (▲)
- ⑥ DOWN button (▼)
- ⑦ Operation and battery status indicator, red LED (lit = ON/flashing = LOW BATTERY)
- ⑧ ON/OFF button (serves as the ESC (cancel) key in the operating menu)
- ⑨ MUTE switch
- ⑩ SET button
- ⑪ Battery compartment cover









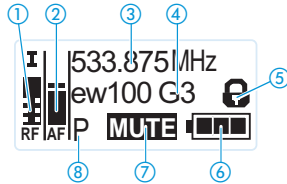

## Overview of the displays of the EK 100 G3

After switch-on, the diversity receiver displays the standard display “Frequency/Name”.  
For further illustrations and examples of the different standard displays, refer to page 22.

The display backlighting is automatically reduced after approx. 20 seconds.







Display	Meaning
① RF level “RF” (Radio Frequency)	 <p>Diversity display:   Antenna input I is active   Antenna input II is active                      RF signal level:                      Field strength of the received signal                      Squelch threshold level</p>
② Audio level “AF” (Audio Frequency)	 <p>Modulation of the transmitter                      Peak hold function                      When the display shows full deflection, the audio input level is excessively high.</p>
③ Frequency	Current receiving frequency
④ Name	Freely selectable name of the receiver
⑤ Lock mode icon	Lock mode is activated
⑥ Battery status	Charge status:  approx. 100%  approx. 70%  approx. 30%  Charge status is critical; in addition, the red <b>LOW BATT LED</b> ③ is flashing.
⑦ Muting function “MUTE” or line output level AF OUT	<p>“Mute” is only displayed on the “Frequency/Name” standard display (see page 22) when no RF signal is being received. The diversity receiver then does not output an audio signal.</p> <p>The line output level <b>AF OUT</b> is only displayed on the “Frequency bank/Channel/Name” standard display (see page 22).</p>
⑧ Pilot tone “P”	Activated pilot tone evaluation

## Overview of the displays of the SK 100/SKM 100/SKP 100 G3

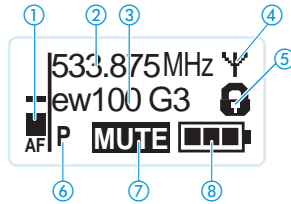
After switch-on, the transmitter displays the standard display “Frequency/Name”. For further illustrations and examples of the different standard displays, refer to page 22.

The display backlighting is automatically reduced after approx. 20 seconds.

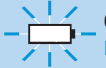

Display	Meaning
① Audio level “AF”	Modulation of the SK/SKM/SKP 100 G3 with peak hold function.
② Frequency	Current transmission frequency
③ Name	Freely selectable name of the transmitter
④ Transmission icon	RF signal is being transmitted
⑤ Lock mode icon	Lock mode is activated
⑥ Pilot tone “P”	Pilot tone transmission is activated
⑦ “MUTE”	Audio signal is muted
⑧ Battery status	Charge status:  approx. 100%  approx. 70%  approx. 30%  Charge status is critical, the red <b>LOW BATTERY LED</b> ⑦/④/⑨ is flashing:

## Putting the devices into operation

### EK 100 G3 diversity receiver

#### Inserting the batteries/accupack

For powering the diversity receiver, you can either use two 1.5 V AA size batteries or the rechargeable Sennheiser BA 2015 accupack.

- ▶ Open the battery compartment by pushing the two catches **10** in the direction of the arrows and open the cover **9**.

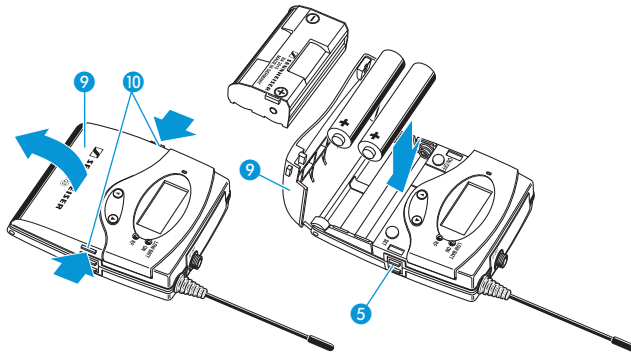

- ▶ Insert the two batteries or the accupack as shown above. Please observe correct polarity when inserting the batteries/accupack.
- ▶ Close the battery compartment by pressing on the center of the cover **9**. The battery compartment cover **9** locks into place with an audible click.

#### Charging the accupack

To charge the BA 2015 accupack:

- ▶ Insert the diversity receiver into the L 2015 charger (optional accessory).



The L 2015 simultaneously charges up to two devices, e.g. two diversity receivers or one diversity receiver and one SK 100 G3 bodypack transmitter.

The L 2015 charger can only charge the BA 2015 accupack. Standard batteries (primary cells) or individual rechargeable battery cells cannot be charged.

### Mounting the diversity receiver to a camera

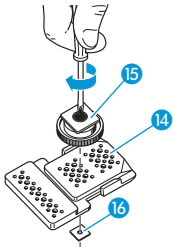

Use the supplied CA 2 camera adapter to mount the receiver to a camera's flash mount.

- ▶ Determine where on the perforated plate 14 the flash mount adapter 15 will need to be fastened so that the receiver can best be attached to the camera.
- ▶ At this position, place a square nut 16 under the perforated plate 14.
- ▶ Fasten the flash mount adapter 15 to the perforated plate 14 using the square nut 16.
- ▶ Lift one side of the belt clip 17 as shown.

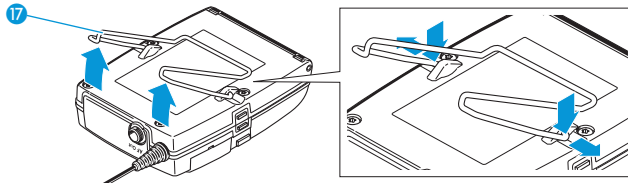

- ▶ Press down the belt clip 17 at one fixing point and pull it out of the receiver housing.
- ▶ Repeat for the other side.
- ▶ Place the perforated plate 14 onto the rear of the receiver.

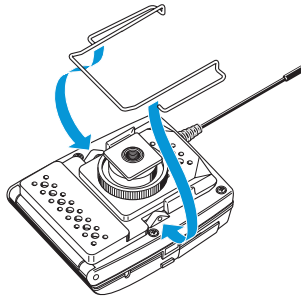

- ▶ Reinsert the belt clip 17.
- ▶ Use one of the supplied line cables to connect the line input of the camera to the socket 1.

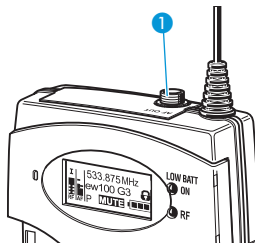

The shield of the line cable serves as the antenna for the second diversity section.

## SK 100 G3 bodypack transmitter

### Inserting the batteries/accupack/Charging the accupack

The procedure is the same as for the EK 100 G3 diversity receiver:

To insert the batteries/accupack:

- ▶ Read the chapter "Inserting the batteries/accupack" on page 10.

To charge the accupack:

- ▶ Read the chapter "Charging the accupack" on page 10.

### Connecting the microphone cable/line cable

The audio input is designed for the connection of condenser microphones. DC powering of the condenser microphones is via the audio input **MIC/LINE 1** (3.5 mm jack socket).

- ▶ Use one of the recommended Sennheiser microphones or the optional CL 2 line cable.
- ▶ Connect the 3.5 mm jack plug **15** from the Sennheiser cable to the 3.5 mm jack socket **MIC/LINE 1**.
- ▶ Lock the 3.5 mm jack plug by screwing down the coupling ring **16** of the cable.
- ▶ Via the operating menu, adjust the sensitivity of the microphone/line input.

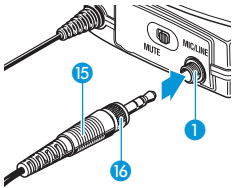

### Attaching and positioning the corresponding microphones

**ME 2/ME 4**

- ▶ Use the microphone clip **17** to attach the microphone to clothing (e.g. tie, lapel).

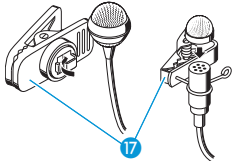

The ME 2 clip-on microphone (shown on the right in the diagram) has an omni-directional pick-up pattern. It is therefore not necessary to position it precisely.

- ▶ Attach the ME 2 microphone as close as possible to the sound source.

The ME 4 clip-on microphone (shown on the left in the diagram) has a cardioid pick-up pattern.

- ▶ Position the ME 4 microphone so that its sound inlet is directed towards the sound source (e.g. mouth).

## Attaching the bodypack transmitter to clothing

You can use the belt clip **18** to attach the bodypack transmitter to clothing (e.g. belt, waist-band).

The belt clip is detachable so that you can also attach the transmitter with the antenna pointing downwards. To do so, withdraw the belt clip **18** from its fixing points and attach it the other way round. The belt clip **18** is secured so that it cannot slide out of its fixing points accidentally.

To detach the belt clip:

- ▶ Lift one side of the belt clip as shown in the diagram on the right-hand side.
- ▶ Press down the belt clip at one fixing point and pull it out of the transmitter housing.
- ▶ Repeat for the other side.

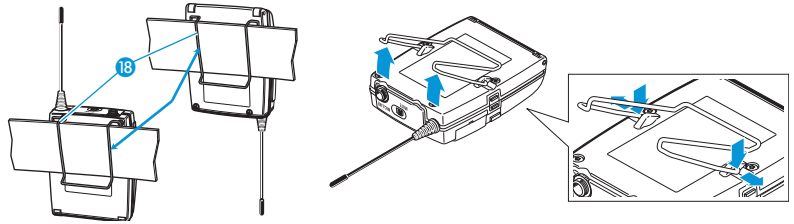

## SKM 100 G3 radio microphone

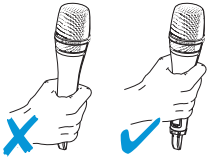

- ▶ Only hold the radio microphone by its body.



If you touch the antenna of the radio microphone during operation, the transmitter's range will be considerably reduced!

## Inserting the batteries/accupack

For powering the radio microphone, you can either use two 1.5 V AA size batteries or the rechargeable Sennheiser BA 2015 accupack.

- ▶ Unscrew the lower part of the radio microphone from the radio microphone's body **3** by turning it counterclockwise.



When unscrewing the radio microphone during operation, the muting function is automatically activated. "MUTE" appears on the display panel.

When screwing the lower part of the radio microphone back to the radio microphone's body, the muting is canceled.

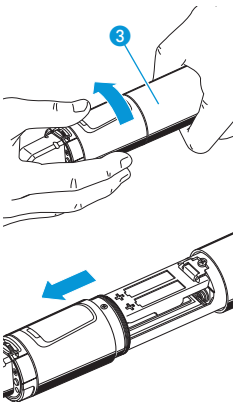

- ▶ Slide back the lower part of the radio microphone as far as it will go.
- ▶ Open the battery compartment cover **13** (see page 14).
- ▶ Insert the batteries or the BA 2015 accupack as shown on the battery compartment cover. Observe correct polarity when inserting the batteries/accupack (see page 14).

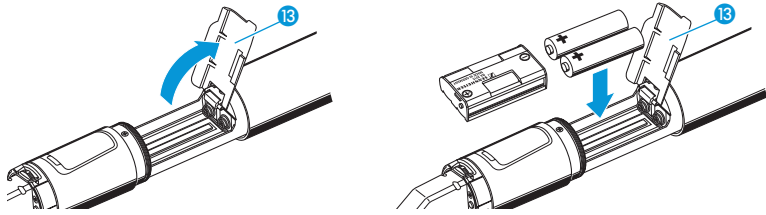

- ▶ Close the battery compartment cover 13.
- ▶ Push the battery compartment into the radio microphone's body.
- ▶ Screw the lower part of the radio microphone back to the radio microphone's body.

### Charging the accupack

To charge the radio microphone with the BA 2015 accupack (optional accessory) installed:

- ▶ Use the LA 2 charging adapter to insert the radio microphone into the L 2015 charger (charger and charging adapter are available as optional accessories).

### Changing the microphone head

The microphone head 1 is easy to change.

- ▶ Unscrew the microphone head 1.

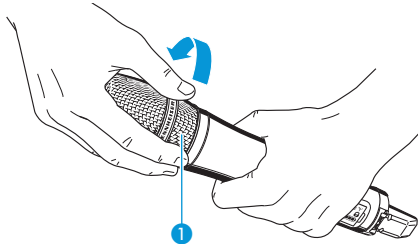

Do not touch the contacts of the radio microphone nor the contacts of the microphone head 1. The contacts can become dirty or damaged if touched.

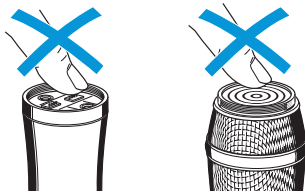

When unscrewing the microphone head 1 during operation, the muting function is automatically activated. "MUTE" appears on the display panel.

When screwing the microphone head 1 back to the radio microphone, the muting is canceled.

- ▶ Screw the desired microphone head to the radio microphone. The radio microphone is operational again.

## Changing the color-coded protection ring

The color-coded protection ring **8** prevents the multi-function switch **11** from accidental operation. Protection rings in different colors are available as accessories. The protection rings allow you to clearly identify each radio microphone.

- ▶ Remove the color-coded protection ring as shown in the left-hand diagram.
- ▶ Put on a new protection ring as shown in the right-hand diagram.

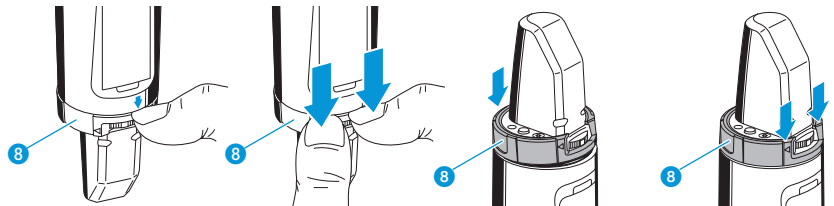

## SKP 100 G3 plug-on transmitter

### Inserting the batteries/accupack

For powering the plug-on transmitter, you can either use two 1.5 V AA size batteries or the rechargeable Sennheiser BA 2015 accupack.

- ▶ Slide the battery compartment cover **11** in the direction of the embossed arrow and open the cover.
- ▶ Insert the two batteries or the accupack as shown below. Please observe correct polarity when inserting the batteries/accupack.
- ▶ Close the battery compartment.  
The battery compartment cover **11** locks into place with an audible click.

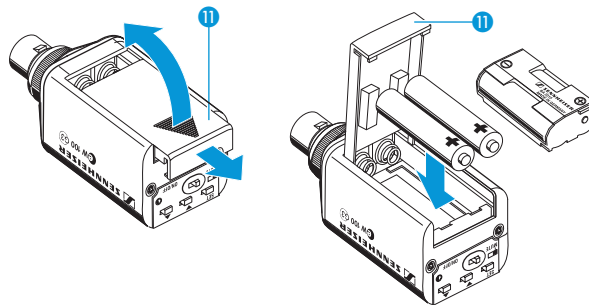

### Charging the accupack

- ▶ Remove the BA 2015 accupack (optional accessory).
- ▶ Insert the BA 2015 accupack into the L 2015 charger (accupack and charger are optional accessories):



The L 2015 charger can only charge the BA 2015 accupack. Standard batteries (primary cells) or individual rechargeable battery cells cannot be charged.



## Plugging the plug-on transmitter onto a microphone

- ▶ Plug the microphone's XLR-3M socket onto the transmitter's XLR-3F socket ①.

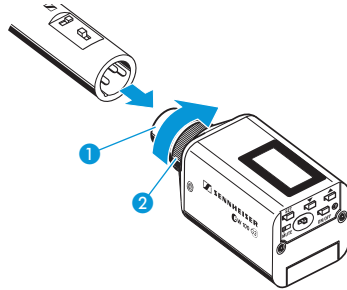

- ▶ Tighten the locking ring ② in the direction of the arrow.



The transmitter uses the microphone body as an antenna – therefore microphones with a metal casing should be used for best signal transmission.

## Using the devices

To establish a transmission link, proceed as follows:

1. Switch the diversity receiver on.
2. Switch a transmitter on.  
The transmission link is established and the diversity receiver's RF level display "RF" reacts.

If you cannot establish a transmission link between transmitter and diversity receiver:

- ▶ Make sure that transmitter and diversity receiver are set to the same frequency bank and to the same channel.
- ▶ If necessary, read the chapter "If a problem occurs ..." on page 29.



It is vital to observe the following notes:

- ▶ Make sure that the desired frequencies are listed in the enclosed frequency information sheet.
- ▶ Make sure that the desired frequencies are approved and legal in your country and, if necessary, apply for an operating license.

## Switching the devices on/off

### EK 100 G3 diversity receiver

To switch the diversity receiver **on**:

- ▶ Push the two battery compartment catches **10** and open the battery compartment cover **9**.

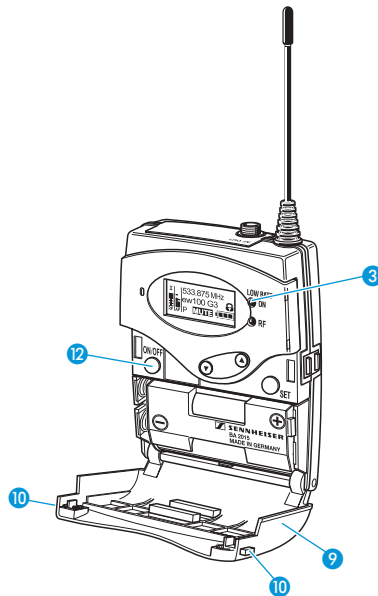

- ▶ Press the **ON/OFF** button **12**.  
The red **ON** LED **3** lights up and the standard display "**Frequency/Name**" appears on the display panel.

To switch the diversity receiver **off**:

- ▶ Press the **ON/OFF** button **12** until "**OFF**" appears on the display panel.  
The red **ON** LED **3** goes off and the diversity receiver switches off.



When in the operating menu, pressing the **ON/OFF** button **12** will cancel your entry (ESC function) and return you to the current standard display.

SK 100 G3 bodypack transmitter, SKM 100 G3 radio microphone and SKP 100 G3 plug-on transmitter

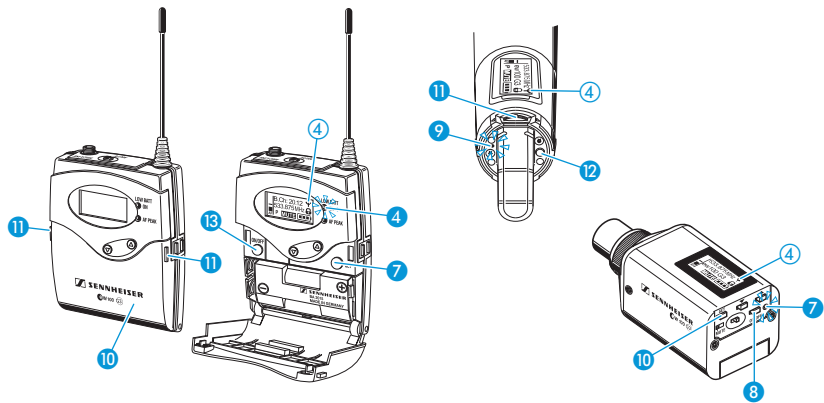

To switch your transmitter **on** (online operation):

**SK 100 G3**

- ▶ Push the two catches **11** and open the battery compartment cover **10**.
- ▶ Briefly press the **ON/OFF** button **13**. The bodypack transmitter transmits an RF signal. The red **ON LED** **4** lights up and the standard display "**Frequency/Name**" appears on the display panel. The transmission icon **4** is displayed.

**SKM 100 G3**

- ▶ Briefly press the **ON/OFF** button **12**. The radio microphone transmits an RF signal. The red **ON LED** **9** lights up and the standard display "**Frequency/Name**" appears on the display panel. The transmission icon **4** is displayed.

**SKP 100 G3**

- ▶ Briefly press the **ON/OFF** button **8**. The plug-on transmitter transmits an RF signal. The red **ON LED** **7** lights up and the standard display "**Frequency/Name**" appears on the display panel. The transmission icon **4** is displayed.



You can switch your transmitter on and deactivate the RF signal on switch-on. For more information, refer to page 19.

To switch your transmitter **off**:

- ▶ If necessary, deactivate the lock mode (see page 20).
- ▶ Press the **ON/OFF** button **13** until "**OFF**" appears on the display panel. The display panel turns off. The red **ON LED** **4** goes off.
- ▶ Press the **ON/OFF** button **12** until "**OFF**" appears on the display panel. The display panel turns off. The red **ON LED** **9** goes off.
- ▶ Press the **ON/OFF** button **8** until "**OFF**" appears on the display panel. The display panel turns off. The red **ON LED** **7** goes off.



When in the operating menu, pressing the **ON/OFF** button will cancel your entry (ESC function) and return you to the current standard display.

To switch your transmitter **on** and to **deactivate the RF signal on switch-on** (offline operation):

### SK 100 G3

- ▶ Keep the **ON/OFF** button **13** pressed until “RF Mute On?” appears on the display panel.
- ▶ Press the **SET** button **7**.

### SKM 100 G3

- ▶ Keep the **ON/OFF** button **12** pressed until “RF Mute On?” appears on the display panel.
- ▶ Press the multi-function switch **11**.

### SKP 100 G3

- ▶ Keep the **ON/OFF** button **8** pressed until “RF Mute On?” appears on the display panel.
- ▶ Press the **SET** button **10**.

The transmission frequency is displayed but the transmitter does not transmit an RF signal.

The transmission icon **4** is not displayed.

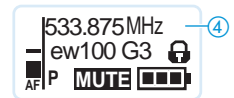

Use this function to save battery power or to prepare a transmitter for use during live operation without causing interference to existing transmission links.

To **activate** the RF signal:

- ▶ Briefly press the **ON/OFF** button **13**. “RF Mute Off” appears on the display panel.
  - ▶ Press the **SET** button **7**. The transmission icon **4** is displayed again.
- ▶ Briefly press the **ON/OFF** button **12**. “RF Mute Off” appears on the display panel.
  - ▶ Press the multi-function switch **11**. The transmission icon **4** is displayed again.
- ▶ Briefly press the **ON/OFF** button **8**. “RF Mute Off” appears on the display panel.
  - ▶ Press the **SET** button **10**. The transmission icon **4** is displayed again.

## Synchronizing a transmitter with the diversity receiver

You can synchronize a suitable transmitter of the ew 100 G3 series with the diversity receiver. During synchronization, the following parameters are transferred to the transmitter:

Setting	Transferred parameters
“Frequency Preset”	Currently set frequency
“Name”	Freely selectable name currently set on the receiver
“Pilot Tone”	Current pilot tone setting of the receiver (“Inactive”/“Active”)

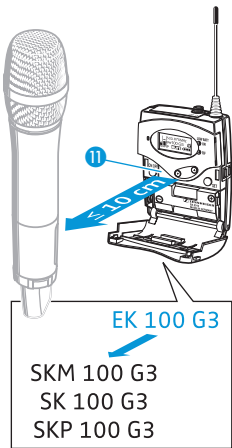

To transfer the parameters:

- ▶ Switch the transmitter and the diversity receiver on.
- ▶ On the receiver, call up the "Sync" menu item. "Sync" appears on the display panel of the diversity receiver.
- ▶ Place the infra-red interface of the transmitter (see page 5 to page 7) in front of the infra-red interface of the diversity receiver **11**.

The parameters are transferred to the transmitter. When the transfer is completed, "✓" appears on the display panel of the diversity receiver. The receiver then switches back to the current standard display.

To cancel the transfer:

Press the ON/OFF button **12** on the diversity receiver.

"X" appears on the display panel of the receiver. "X" also appears if no suitable transmitter was found (wrong frequency range/wrong generation).

## Deactivating the lock mode temporarily

You can activate or deactivate the automatic lock mode via the "Auto Lock" menu item (see page 23). If the lock mode is activated, you have to temporarily deactivate it in order to be able to operate the devices:

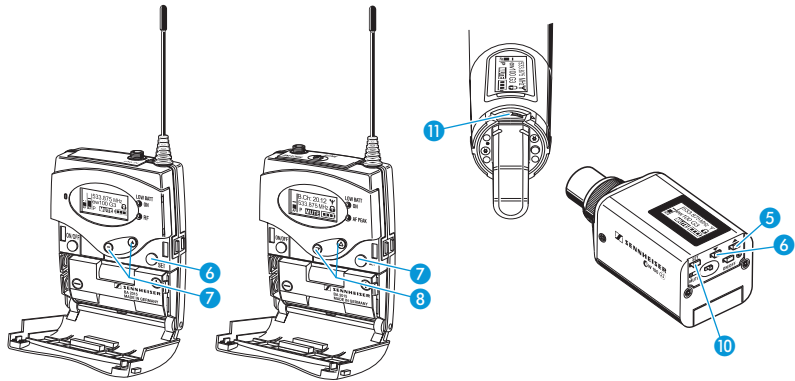

### EK 100 G3/SK 100 G3

- ▶ Press the SET button **6** (EK) or **7** (SK).

"Locked" appears on the display panel.

- ▶ Press the rocker button **7** (EK) or **8** (SK).

"Unlock?" appears on the display panel.

- ▶ Press the SET button **6** (EK) or **7** (SK).

### SKM 100 G3

- ▶ Press the multi-function switch **11**.

- ▶ Move the multi-function switch **11** upwards/downwards.

- ▶ Press the multi-function switch **11**.

### SKP 100 G3

- ▶ Press the SET button **10**.

- ▶ Press the UP button **5** / DOWN button **6**.

- ▶ Press the SET button **10**.

The lock mode is temporarily deactivated.

How you are using the devices determines how long the lock mode remains deactivated:

#### When you are in the operating menu

The lock mode remains deactivated until you exit the operating menu.

#### When one of the standard displays is shown

The lock mode is automatically activated after 10 seconds.

The lock mode icon flashes prior to the lock mode being activated again.

## Muting the audio signal or deactivating the RF signal



You can deactivate the RF signal of the transmitters (SKM 100 G3, SK 100 G3, SKP 100 G3) on switch-on. For more information, refer to the chapter "Switching the devices on/off" on page 17.

Using the **ON/OFF** button, you can also activate/deactivate the transmitters' RF signal during operation. To do so, briefly press the **ON/OFF** button and proceed as described on page 19.

### SK 100 G3/SKP 100 G3

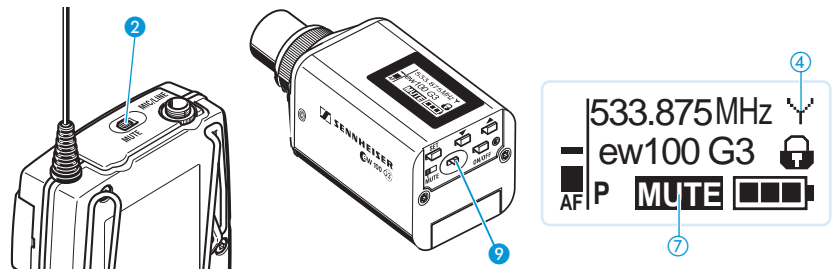

The **MUTE** switch **2** (SK) / **9** (SKP) allows you to mute the audio signal or to deactivate the RF signal. Via the "Mute Mode" menu item, you can set the desired function of the **MUTE** switch **2** (SK) / **9** (SKP):

Setting	Slide the MUTE switch <b>2</b> / <b>9</b> ...	Function
"AF On/Off"	... to the left (position <b>MUTE</b> )	Mutes the audio signal
	... to the right	Unmutes the audio signal
"RF On/Off"	... to the left (position <b>MUTE</b> )	Deactivates the RF signal (offline operation)
	... to the right	Activates the RF signal (online operation)
"Disabled"	No function	

- ▶ From the "Mute Mode" menu item, select the desired setting (see page 25).
- ▶ Exit the operating menu.
- ▶ Slide the **MUTE** switch **2** (SK) / **9** (SKP) to the left, to the position **MUTE**. The transmitter reacts as indicated in the table.

The current state of the muting function or the RF signal is displayed on the display panel of the transmitter:

Audio signal is muted	
Transmitter's display panel:	"MUTE" ⓘ is displayed
Audio signal is activated (muting is canceled)	
Transmitter's display panel:	"MUTE" ⓘ is not displayed
RF signal is deactivated	
Transmitter's display panel:	Transmission icon ⓘ is not displayed, "MUTE" ⓘ is displayed
RF signal is activated	
Transmitter's display panel:	Transmission icon ⓘ is displayed, "MUTE" ⓘ is not displayed

## Selecting a standard display

### EK 100 G3









ON/OFF ▶ Briefly press the ON/OFF button to select a standard display.



Contents of the display	Selectable standard display
	"Frequency/Name" with "MUTE" display ⓘ
	"Frequency bank/Channel/Name" with display of the line output level "AF OUT" ⓘ

### SK 100/SKM 100/SKP 100 G3

To select a standard display:

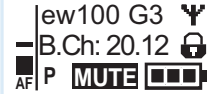
SK 100 G3	SKM 100 G3	SKP 100 G3
  Press the rocker button.	  Move the multi-function switch.	  Press the UP button/DOWN button.
Contents of the display	Selectable standard display	
	"Frequency/Name"	
	"Channel/Frequency"	
	"Name/Channel"	

## Overview of the operating menus



For more detailed information on the operating menus, refer to the individual instruction manuals of the devices. These instruction manuals can be downloaded from the corresponding product pages at [www.sennheiser.com](http://www.sennheiser.com).

### EK 100 G3

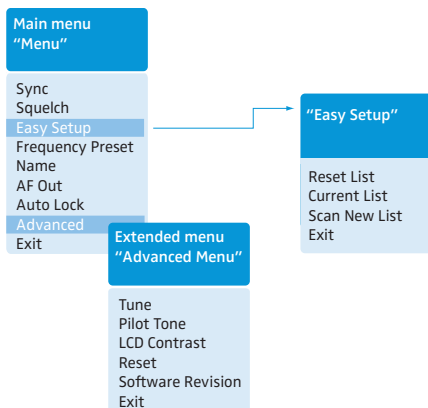



When one of the standard displays is shown on the display panel, you can get into the main menu by pressing the **SET** button **6**. The extended menu **“Advanced Menu”** and the **“Easy Setup”** menu can be accessed via the corresponding menu items.

Display	Function of the menu item
<b>Main menu “Menu”</b>	
Sync	Synchronizes a transmitter with the diversity receiver
Squelch	Adjusts the squelch threshold Adjustment range: <b>“Low”</b> , <b>“Middle”</b> , <b>“High”</b> , can be switched off Special function (for servicing purposes only): With the squelch threshold set to <b>“Low”</b> , you switch the squelch off by keeping the <b>DOWN</b> rocker button <b>7</b> pressed for 3 seconds. If you then press the <b>UP</b> button <b>7</b> , you switch the squelch on again.
Easy Setup	Scans for unused frequency presets, releases and selects frequency presets
Frequency Preset	Changes the frequency bank and the channel
Name	Enters a freely selectable name
AF Out	Adjusts the audio output level Adjustment range: <b>-30 dB</b> to <b>+12 dB</b> , adjustable in steps of 6 dB
Auto Lock	Activates/deactivates the automatic lock mode
Advanced	Calls up the extended menu <b>“Advanced Menu”</b>
Exit	Exits the operating menu and returns to the current standard display
<b>“Easy Setup”</b>	
Reset List	Releases all locked frequency presets
Current List	Selects an unused frequency preset
Scan New List	Automatically scans for unused receiving frequencies (frequency preset scan)
Exit	Exits the menu <b>“Easy Setup”</b> menu and returns to the main menu
<b>Extended menu “Advanced Menu”</b>	
Tune	Sets the receiving frequencies for the frequency bank <b>“U”</b> Sets a channel and a receiving frequency for the frequency bank <b>“U”</b> : ▶ Select this menu item and call it up by pressing the <b>SET</b> button <b>6</b> until the channel selection appears.
Pilot Tone	Activates/deactivates the pilot tone evaluation
LCD Contrast	Adjusts the contrast of the display panel
Reset	Resets the diversity receiver
Software Revision	Displays the current software revision
Exit	Exits the extended menu <b>“Advanced Menu”</b> and returns to the main menu

## SK 100/SKM 100/SKP 100 G3

### SK 100 G3

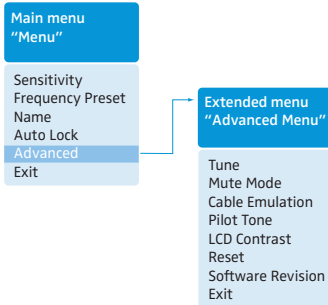

### SKM 100 G3

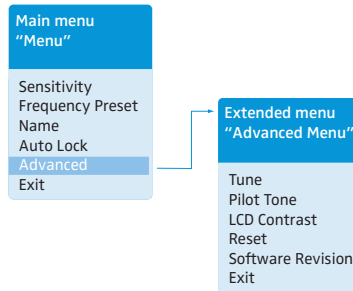

### SKP 100 G3

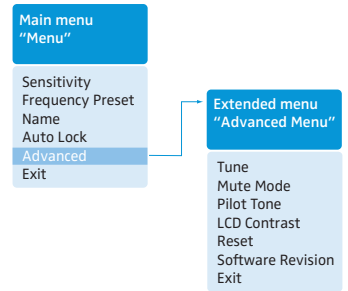

Display	Function of the menu item
<b>Main menu "Menu"</b>	
Sensitivity	Adjusts the sensitivity "AF"
Frequency Preset	Changes the frequency bank and the channel
Name	Enters the transmitter name
Auto Lock	Activates/deactivates the automatic lock mode
Advanced	Calls up the extended menu "Advanced Menu"
Exit	Exits the operating menu and returns to the current standard display
<b>Extended menu "Advanced Menu"</b>	
Tune	Sets the transmission frequencies for the frequency bank "U" Sets a channel and a transmission frequency for the frequency bank "U" ▶ Select this menu item and call it up by pressing the SET button (SK, SKP)/the multi-function switch (SKM) until the channel selection appears.
Mute Mode (SK, SKP only)	Sets the mode for the MUTE switch
Cable Emulation (SK only)	Emulates guitar cable capacities
Pilot Tone	Activates/deactivates the pilot tone transmission
LCD Contrast	Adjusts the contrast of the display panel
Reset	Resets the transmitter
Software Revision	Displays the current software revision
Exit	Exits the extended menu "Advanced Menu" and returns to the main menu

## Synchronizing transmitters with diversity receivers

When synchronizing transmitters with diversity receivers, please observe the following:

- 
- ▶ Make sure that the desired frequencies are listed in the enclosed frequency information sheet.
  - OR:
  - ▶ Contact your Sennheiser partner who will be pleased to calculate intermodulation-free frequencies for you.
  - ▶ Make sure that the desired frequencies are approved and legal in your country and, if necessary, apply for an operating license.
- 

Upon delivery, transmitter and diversity receiver are synchronized with each other. If, however, you cannot establish a transmission link between transmitter and diversity receiver, you have to synchronize the channels of the devices:

- ▶ Deactivate the RF signal on all transmitters (see page 21).  
This prevents that, during the frequency scan, the channels used by switched-on transmitters are displayed as “used”.
- ▶ With a diversity receiver, perform a frequency preset scan to scan the frequency banks for unused channels (“[Scan New List](#)”, see page 24).
- ▶ Select a frequency bank and a channel on this diversity receiver (“[Current List](#)”, see page 24).  
If you want to set up a multi-channel system, select a frequency bank with a sufficient number of unused channels for all planned transmission links.
- ▶ Synchronize a transmitter with the diversity receiver (see page 19).  
The receiver’s frequency, name and pilot tone setting are transferred to the transmitter.
- OR:
- ▶ Manually set the transmitter to the same frequency bank and channel that you set on the receiver.
- ▶ Activate the RF signal on the transmitter.  
The transmission link is established.

If you want to set up a multi-channel system:

- ▶ Repeat the following 4 steps for each additional transmission link:
  - Perform a frequency preset scan with the next diversity receiver.
  - Select a channel from the same frequency bank as with the first diversity receiver.
  - Synchronize a transmitter with the diversity receiver.
  - Activate the RF signal on the transmitter.

## Using freely selectable frequencies

You can also freely select the receiving frequencies and store these frequencies in the frequency banks "U".



**It might be that the freely selected frequencies are not intermodulation-free**

If you use frequencies from the frequency bank "U", it might be that the frequencies are not intermodulation-free.

- ▶ Contact your Sennheiser partner who will be pleased to calculate intermodulation-free frequencies for you (see [www.sennheiser.com](http://www.sennheiser.com)).

- 
- ▶ Set each diversity receiver to the frequency bank "U".
  - ▶ On one of the receivers, select a channel within this frequency bank and assign this channel one of the calculated receiving frequencies ("Tune", see page 24).
  - ▶ Synchronize a transmitter with this receiver (see page 19).  
OR:
  - ▶ Manually set the transmitter to the same frequency bank and channel that you set on the receiver.
  - ▶ Repeat for the remaining transmitters and receivers as described above.

## Cleaning the devices

---

**CAUTION!**

**Liquids can damage the electronics of the devices!**

Liquids entering the housing of the devices can cause a short-circuit and damage the electronics.

- ▶ Keep all liquids away from the devices.

- 
- ▶ Use a cloth to clean the devices from time to time. Do not use any solvents or cleansing agents.

### SKM 100 G3

To clean the radio microphone's sound inlet basket:

- ▶ Unscrew the upper sound inlet basket from the microphone head by turning it counter-clockwise.

---

**CAUTION!**

**Liquids can damage the microphone head!**

Liquids can damage the microphone head.

- ▶ Only clean the upper sound inlet basket.

- 
- ▶ Remove the foam insert.
  - ▶ There are two ways to clean the sound inlet basket:
    - Use a cloth to clean the upper sound inlet basket from the inside and outside
    - or scrub with a brush and rinse with clear water.
  - ▶ If necessary, clean the foam insert with a mild detergent or replace the foam insert.
  - ▶ Dry the upper sound inlet basket.
  - ▶ Dry the foam insert.
  - ▶ Reinsert the foam insert.
  - ▶ Replace the sound inlet basket on the microphone head and screw it tight.

You should also clean the contact rings of the microphone head from time to time:

- ▶ Wipe the contact rings of the microphone head with a cloth.

## If a problem occurs ...

### EK 100 G3

Problem	Possible cause	Possible solution
Diversity receiver cannot be operated, "Locked" appears on the display panel	Lock mode is activated	Deactivate the lock mode (see page 20).
No operation indication	Batteries are flat or accupack is flat	Replace the batteries or recharge the accupack (see page 10).
No RF signal	Transmitter and receiver are not on the same channel	Set the transmitter and receiver to the same channel. Synchronize the transmitter with the receiver (see page 19).
	Transmission range is exceeded	Reduce the distance between receiver and transmitter.
	RF signal is deactivated ("RF Mute")	Activate the RF signal (see page 21).
RF signal available, no audio signal, "MUTE" appears on the display panel	Transmitter is muted	Cancel the muting (see page 21).
	Receiver's squelch threshold is adjusted too high	Reduce the squelch threshold setting on the receiver (see page 24).
	Transmitter doesn't transmit a pilot tone	Deactivate the pilot tone evaluation (see page 24).
Audio signal has a high level of background noise	Transmitter sensitivity is adjusted too low	Adjust the transmitter sensitivity correctly ("Sensitivity", see page 25).
Audio signal is distorted	Transmitter sensitivity is adjusted too high	Adjust the transmitter sensitivity correctly ("Sensitivity", see page 25).
	Receiver's audio output level is adjusted too high	Reduce the audio output level ("AF Out", see page 24).
No access to a certain channel	During scanning, an RF signal has been detected on this channel and the channel has been locked	Set the transmitter operating on this channel to a different channel and redo the frequency preset scan (see page 24).
	During scanning, a transmitter of your system operating on this channel has not been switched off	Switch the transmitter off and redo the frequency preset scan (see page 24).

## SK 100/SKM 100/SKP 100 G3

Problem	Possible cause	Possible solution
Transmitter cannot be operated, "Locked" appears on the display panel	Lock mode is activated	Deactivate the lock mode (see page 20).
No operation indication	Batteries are flat or accupack is flat	Replace the batteries or recharge the accupack (see page 13).
No RF signal at the receiver	Transmitter and receiver are not on the same channel	Synchronize the transmitter with the receiver (see page 19). Set the transmitter to the same channel as the receiver.
	Transmission range is exceeded	Reduce the distance between receiver and transmitter.
	RF signal is deactivated ("RF Mute")	Activate the RF signal (see page 21).
RF signal available, no audio signal, "MUTE" appears on the display panel	Transmitter is muted (MUTE)	Cancel the muting (see page 21).
	Receiver's squelch threshold is adjusted too high	Reduce the squelch threshold setting on the receiver.
	Transmitter doesn't transmit a pilot tone	Activate or deactivate the pilot tone transmission (see page 25).
Audio signal has a high level of background noise or is distorted	Transmitter's sensitivity is adjusted too low/too high	Adjust the input sensitivity (see page 25).

If a problem occurs that is not listed in the above table or if the problem cannot be solved with the proposed solutions, please contact your local Sennheiser partner for assistance. To find a Sennheiser partner in your country, search at [www.sennheiser.com](http://www.sennheiser.com) under "Service & Support".

# Specifications

## System

Modulation	wideband FM
Frequency ranges	516–558, 566–608, 626–668, 734–776, 780–822, 823–865 MHz (A to E, G, see page 3)
Frequencies	1,680 frequencies, tuneable in steps of 25 kHz 20 frequency banks, each with up to 12 factory-preset channels 1 frequency bank with up to 12 user programmable channels
Switching bandwidth	42 MHz
Frequency stability	±10 ppm (–10°C to +55°C)
Compander system	Sennheiser HDX
Nominal/peak deviation	±24 kHz/±48 kHz
Pilot tone (frequency/deviation)	32.7665 kHz/±2 kHz
THD	≤ 0.9%
Temperature range	–10°C to +55°C

## EK 100 G3

Receiver principle	adaptive diversity
Sensitivity (with HDX, peak deviation)	< 1.6 µV for 52 dBA <sub>rms S/N</sub>
Adjacent channel rejection	typ. ≥ 65 dB
Intermodulation attenuation	typ. ≥ 65 dB
Blocking	≥ 70 dB
Squelch	Off, Low: 5 dBµV, Middle: 15 dBµV, High: 25 dBµV can be switched off
Pilot tone squelch	≥ 60 dB
S/N ratio (1 mV, peak deviation)	
AF output voltage (at peak deviation, 1 kHz AF)	3.5 mm jack socket: +11 dBu (mono, unbalanced)
Adjustment range of audio output level (“AF Out”)	42 dB, adjustable in steps of 6 dB
Power supply	2 AA size batteries, 1.5 V or BA 2015 accupack
Nominal voltage	2.4 V ---
Power consumption:	
• at nominal voltage	typ. 140 mA
• with switched-off diversity receiver	≤ 25 µA
Operating time	typ. 8 hrs
Dimensions	approx. 82 x 64 x 24 mm
Weight (incl. batteries)	approx. 120 g

## In compliance with

Europe	 EMC EN 301489-1/-9 Radio EN 300422-1/-2 Security EN 60065
USA	 47 CFR 15 subpart B



Approved by

Canada

Industry Canada RSS 123

IC 2099A-G3EK100

limited to 806 MHz

**SK 100/SKM 100/SKP 100 G3**

RF output power at 50 Ω

typ. 30 mW

Pilot tone squelch

can be switched off

AF frequency response

SK

microphone: 80–18,000 Hz

line: 25–18,000 Hz

80–18,000 Hz

SKM/SKP

Signal-to-noise ratio (1 mV RF, peak deviation)

≥ 110 dBA

SK/SKM/SKP

Max. input voltage (SK) microphone/line

3 V<sub>rms</sub>

Max. input voltage (SKP)

3.3 V<sub>rms</sub>

Input impedance SK microphone/line

40 kΩ, unbalanced/1 MΩ

Input impedance SKP

60 kΩ, unbalanced

Input capacitance SK

switchable

Adjustment range of input sensitivity

SK: 60 dB, adjustable in steps of 3 dB

SKM, SKP: 48 dB, adjustable in steps of 6 dB

Power supply

2 AA size batteries, 1.5 V

or BA 2015 accupack

Nominal voltage

2.4 V = = =

Current consumption

at nominal voltage

typ. 180 mA

with switched-off transmitter

≤ 25 μA

Operating time

typ. 8 hrs

Dimensions

SK: approx. 82 x 64 x 24 mm

SKM: approx. ∅ 50 x 265 mm

SKP: approx. 105 x 43 x 43 mm

Weight (incl. batteries)

SK: approx. 160 g

SKM: approx. 450 g

SKP: approx. 195 g

### In compliance with (SK, SKM and SKP 100 G3)

Europe

CE	EMC	EN 301489-1/-9
	Radio	EN 300422-1/-2
	Security	EN 60065, EN 62311 (SAR)

### Approved by (SK, SKM and SKP 100 G3)

	SK 100 G3	SKM 100 G3	SKP 100 G3
Canada	Industry Canada RSS 123, IC: 2099A-G3SK limited to 806 MHz	Industry Canada RSS 123, IC: 2099A-G3SKMEM limited to 806 MHz	Industry Canada RSS 123, IC: 2099A-G3SKP limited to 806 MHz
USA	FCC-Part 74, FCC-ID: DMO G3SK limited to 698 MHz	FCC-Part 74, FCC-ID: DMO G3SKMEM limited to 698 MHz	FCC-Part 74, FCC-ID: DMOG3SKP limited to 698 MHz



For accessories and information on connector assignment, visit the ew G3 product page at [www.sennheiser.com](http://www.sennheiser.com).

### Microphones (SK 100 G3)

	ME 2	ME 4
Microphone type	condenser	condenser
Sensitivity	20 mV/Pa	40 mV/Pa
Pick-up pattern	omni-directional	cardioid
Max. SPL	130 dB SPL	120 dB SPL

### MMD 835-1 microphone head (SKM 100 G3)

	MMD 835-1
Microphone type	dynamic
Sensitivity	2.1 mV/Pa
Pick-up pattern	cardioid
Max. SPL	154 dB SPL

### Polar diagram and frequency response curve of the MMD 835-1 microphone head (SKM 100 G3)

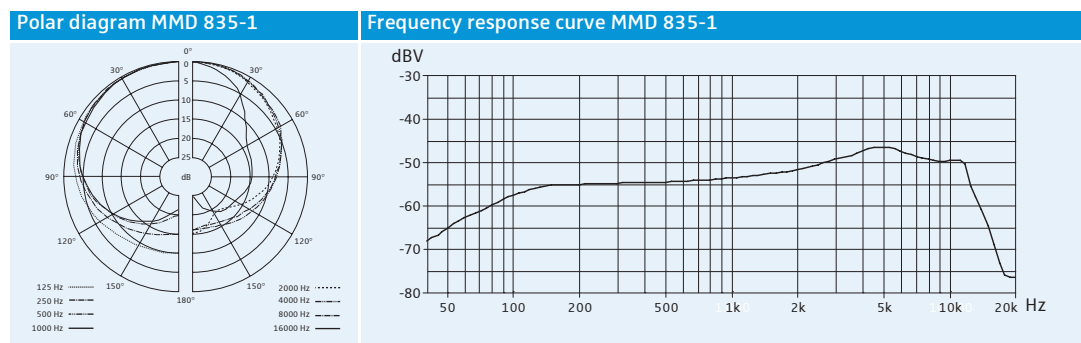

# Manufacturer Declarations

## Warranty

Sennheiser electronic GmbH & Co. KG gives a warranty of 24 months on this product.

For the current warranty conditions, please visit our web site at [www.sennheiser.com](http://www.sennheiser.com) or contact your Sennheiser partner.

## In compliance with the following requirements

- RoHS Directive (2002/95/EC)
- WEEE Directive (2002/96/EC)



Please dispose of these products at the end of their operational lifetime by taking them to your local collection point or recycling center for such equipment.

- Battery Directive (2006/66/EC)



The supplied batteries or rechargeable batteries can be recycled. Please dispose of them as special waste or return them to your specialist dealer. In order to protect the environment, only dispose of exhausted batteries.

## CE Declaration of Conformity

- EK 100 G3: CE0682 SK / SKM / SKP 100 G3: CE0682
- R&TTE Directive (1999/5/EC)

The declarations are available at [www.sennheiser.com](http://www.sennheiser.com).

Before putting the devices into operation, please observe the respective country-specific regulations.

## Statements regarding FCC and Industry Canada

These devices comply with Part 15 of the FCC Rules and with RSS-210 of Industry Canada. Operation is subject to the following two conditions: (1) these devices may not cause harmful interference, and (2) these devices must accept any interference received, including interference that may cause undesired operation.

This equipment has been tested and found to comply with the limits for a Class B digital device, pursuant to Part 15 of the FCC Rules. These limits are designed to provide reasonable protection against harmful interference in a residential installation. This equipment generates, uses and can radiate radio frequency energy and, if not installed and used in accordance with the instructions, may cause harmful interference to radio communications. However, there is no guarantee that interference will not occur in a particular installation. If this equipment does cause harmful interference to radio or television reception, which can be determined by turning the equipment off and on, the user is encouraged to try to correct the interference by one or more of the following measures:

- Reorient or relocate the receiving antenna.
- Increase the separation between the equipment and receiver.
- Connect the equipment into an outlet on a circuit different from that to which the receiver is connected.
- Consult the dealer or an experienced radio/TV technician for help.

These class B digital devices comply with the Canadian ICES-003.

Changes or modifications made to this equipment not expressly approved by Sennheiser electronic Corp. may void the FCC authorization to operate this equipment.

Before putting the devices into operation, please observe the respective country-specific regulations!

Sennheiser electronic GmbH & Co. KG  
Am Labor 1, 30900 Wedemark, Germany  
[www.sennheiser.com](http://www.sennheiser.com)

Printed in Germany  
Publ. 01/09  
529660/A01