

# MP-85

## Natural Response Vocal Microphone with Mic Control



### Specifications

Element type	Dynamic
Pickup pattern	Super-cardioid
Magnet	Neodymium
Impedance	300 Ohms
Sensitivity	-55 dBV/Pa (1.77 mV) – 1 Pa = 94 dB SPL measured @ 1 kHz
Frequency response	50 Hz to 18 kHz
Weight	0.80 lbs (0.36 kg)
Dimensions	Height 7.25 inches (185 mm), diameter (max): 2.1 inches (54 mm)

### Frequency Response (typical)

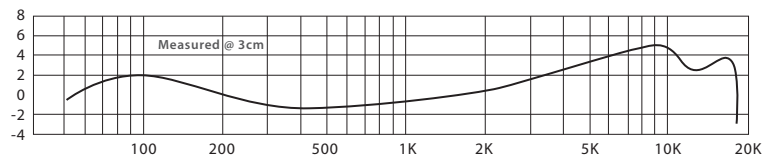

### Polar Pattern

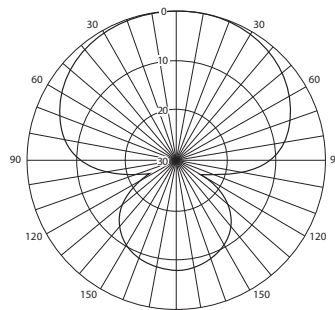

### Microphone Usage

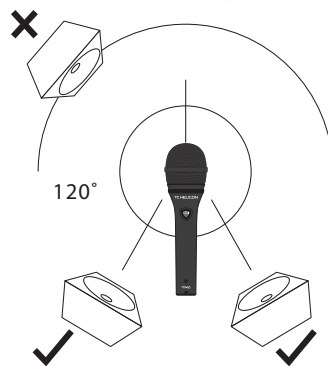

- Avoid facing monitor or PA speakers into the mic.
- The optimum location for monitor speakers with super-cardioid microphones is 120° off-axis.
- Setting monitor levels while singing close (<3 cm) to the mic is best for avoiding feedback.

### Mic Control

The MP-85 has a feature called Mic Control that allows the mic to engage or disengage an effect when connected to a TC Helicon effect pedal. The setup for this functionality varies by product, so consult the documentation for your effects unit. Note that a firmware update may be necessary in order for your product to support mic control.

Music Tribe accepts no liability for any loss which may be suffered by any person who relies either wholly or in part upon any description, photograph, or statement contained herein. Technical specifications, appearances and other information are subject to change without notice. All trademarks are the property of their respective owners. Midas, Klark Teknik, Lab Gruppen, Lake, Tannoy, Turbosound, TC Electronic, TC Helicon, Behringer, Bugera, Auratone and Coolaudio are trademarks or registered trademarks of Music Tribe Global Brands Ltd. © Music Tribe Global Brands Ltd. 2020 All rights reserved.