

SubZero

MODULAR PA SYSTEM

HiCAST-S21

USER MANUAL

WARNING!

Do not open cover. No user-serviceable parts inside. Refer servicing to qualified service personnel
Do not place the product in a location near a heat source such as a radiator, or in an area subject to direct sunlight, excessive dust, mechanical vibration or shock
The product must not be exposed to dripping or splashing and no objects filled with liquids, such as vases, shall be placed on the product
No naked flame sources, such as lighted candles, should be placed on the product
Allow adequate air circulation and avoid obstructing vents (if present) to prevent internal heat build-up.
The ventilation must not be impeded by covering the appliance with items such as newspapers, tablecloths, curtains etc.
To prevent injury, this appliance must be securely attached to the floor/wall in accordance with the installation instructions.

VAROVÁNÍ!

Nezakrývejte. Uvnitř nejsou žádné součásti opravitelné uživatelem. S požadavkem na servis se odkažte na kvalifikované servisní oddělení.
Neumísťujte produkt v blízkosti zdroje tepla, jako je radiátor, nebo na místo s přímým slunečním světlem, nadměrným prašením, mechanickými vibracemi nebo šokem.
Produkt nesmí přijít do kontaktu s vodou a žádné objekty naplněné tekutinami, jako například vázy, by neměly být umístěny na produkt.
Žádné zdroje otevřeného ohně, jako například svíčky, by neměly být umístěny na produkt.
Umožněte dostatečnou cirkulaci vzduchu a vyhněte se obstrukci ventilátorů (pokud jsou přítomné) pro předejítí interního přehřívání. Ventilace nesmí být narušena překrytím zařízení výrobky jako např. noviny, kuchyňské utěrky, záclony apod.
Pro předejítí zranění, toto zařízení musí být bezpečně připevněno ke zdi/podlaze v souladu s instrukcemi instalace.

DVARSEL!

Dækslet må ikke åbnes. Ingen bruger-udsiktelige dele indeni. Overlad service til kvalificeret service personale
Placer ikke produktet i nærheden af varmekilder såsom en radiator eller i direkte sollys, meget støv, mekaniske vibrationer eller stød
Produktet må ikke udsættes for vand eller stænk, og ingen genstande fyldt med væsker, f.eks. vaser, må anbringes på produktet
Må ikke placere nær åben ild, tændte stearinlys må ikke placeres på produktet
Vær sikker på at der er tilstrækkelig luftcirkulation og undgå at dække ventiler (hvis der er nogen) for at undgå at produktet bliver varmt. Ventilationsen må ikke blokeres med overdækning af apparatet med genstande som aviser, dug, gardiner osv.
For at undgå skade skal dette apparat være fastgjort forsvarligt til gulv/væg i overensstemmelse med installationsvejledningen.

WAARSCHUWING!

Maak de behuizing niet open. Dit toestel bevat geen onderdelen die door de gebruiker kunnen worden vervangen. Laat onderhoud over aan bevoegd onderhoudspersoneel.
Plaats het product niet in de buurt van een hittebron zoals een radiator of in direct zonlicht of in een stofrijke omgeving, mechanische vibratie of schok.
Plaats het product niet in de buurt van spatende of lekkende voorwerpen gevuld met een vloeistof zoals bijkvoorbeeld een vaas.
Er mogen geen open vlammen zoals aangestoken kaarsen op de apparatuur worden geplaatst.
Zorg om overhitting te voorkomen voor voldoende ventilatie en bellemmer ventilatorroosters niet.
Bedenk het product niet met dingen zoals kranten, tafellakens, gordijnen etc.
Om verwondingen te voorkomen moet dit product goed worden bevestigd aan de vloer of de wand, naar gelang de instructies.

VAROITUS!

Älä avaa kanta. Ei sisällä käyttäjä-huollettavia osia. Huollot saa suorittaa vain pätevät huoltomies.
Älä säilytä tuotetta minkään kuuman lähellen, kuten patteri tai suorassa auringonpaisteessa, pölyisessä, mekaanisessa värinässä tai iskussa
Tuotetta ei saa altistaa tippuvallle tai loiskeelle tai nesteitä sisältäviä tuotteita kuten maljakko eivät saa olla tuotteen lähetyvillä
Avotulia kuten sytytetty kynttilä ei saa olla tuotteen päällä.
Salli riittävä ilmankierto ja välttä tuuletusaukkojen tukkiminen (jos sellaisia on olemassa) estämään sisäisen lämmön muodostuminen. Tuuletusta ei saa estää peittämillä laite esineillä, kuten sanomalehdillä, pöytäliinoilla, verhoilla jne.
Loukkaantumisen estämiseksi laite on kiinnitettävä tukevasti lattiaan / seinään asennuksen ohjeiden mukaisesti.

ATTENTION!

Ne pas ouvrir le couvercle. Aucune pièce interne réparable par l'utilisateur. Confier la réparation à du personnel de réparation qualifié
Ne pas laisser l'appareil à proximité d'une source de chaleur telle qu'un radiateur, dans un endroit directement exposé aux rayons du soleil, trop poussiéreux, ou pouvant subir des chocs mécaniques
L'appareil ne doit pas être exposé aux gouttes d'eau et aux éclaboussures, et aucun objet rempli de liquide, tel qu'un vase, ne doit être posé dessus
Ne placer aucune source de flamme nue, telle qu'une bougie allumée, sur l'appareil
Assurer une circulation d'air suffisante et éviter d'obstruer les fentes (le cas échéant) afin d'éviter une surchauffe interne. La ventilation ne doit pas être bloquée en couvrant l'appareil avec des objets tels que des journaux, des nappes, des rideaux, etc.
Afin d'éviter tout risque de blessure, cet appareil doit être fixé au sol ou au mur de manière sécurisée, conformément aux instructions d'installation.

WARNING!

Öffnen Sie nicht das Gehäuse. Im Inneren befinden sich keine vom Benutzer zu wartenden Teile.
Überlassen Sie Wartungsarbeiten qualifiziertem Fachpersonal.
Stellen Sie das Produkt nicht an einen Ort in der Nähe einer Wärmequelle wie etwa eines Heizkörpers oder in einem Bereich mit direktem Sonnenlicht, übermäßigem Staub, mechanischen Vibrationen oder Stößen.
Schützen Sie das Produkt vor tropfenden oder spritzenden Flüssigkeiten, und stellen Sie keine mit Flüssigkeiten gefüllten Gegenstände wie Vasen auf das Produkt.
Offene Feuerquellen wie Kerzen dürfen nicht auf dem Gerät abgestellt werden.
Sorgen Sie für eine ausreichende Luftzirkulation und vermeiden Sie, dass die Lüftungsschlitze (falls vorhanden) abgedeckt werden, um einen internen Wärmestau zu verhindern. Die Belüftung darf nicht durch Abdecken des Gerätes mit Gegenständen wie Zeitungen, Tischdecken, Vorhängen usw. blockiert werden.
Um Verletzungen zu vermeiden, muss dieses Gerät gemäß den Installationsanweisungen sicher am Boden bzw. an der Wand befestigt werden.

AVVERTIMENTO!

Non aprire il coperchio. Se fosse necessario, riferirsi ad un esperto.
Non esporre il prodotto a fonti di calore, luce del sole diretta, polvere, vibrazioni meccaniche o altri possibili shock.
Non esporre il prodotto a perdite di liquido o a spruzzi. Non appoggiare nessun oggetto contenente acqua sul prodotto.
Non esporre il prodotto a fuoco, candele o oggetti simili.
Assicurarsi la circolazione dell'aria e non ostruire le ventole, se presenti, per evitare il surriscaldamento. La ventilazione non deve subire impedimenti dovuti a giornali, tovaglie, tende, ecc.
Per evitare danni, il prodotto deve essere appoggiato a terra o installato al muro in modo sicuro e stabile, secondo le istruzioni.

EN

ADVARSEL!

Ikke åpne dekslet. Inneholder ingen deler som kan brukes. Overlat reparaasjon til kvalifisert servicepersonell.
Ikke plasser produktet i nærheten av varmekilder som f.eks. en radiator, eller i områder som er utsatt for direkte sollys, mye støv, mekanisk vibrasjon eller støt.
Produktet må ikke utsettes for drypping eller sprutting, og gjenstander som er fylt med væsker, som f.eks. vaser, skal ikke plasseres på produktet.
Åpne flammer, som f.eks. tente lys, bør ikke plasseres på produktet.
Tillat tilstrækkelig luft sirkulasjon og unngå å blokkere ventiler (hvis tilstede) for å forhindre intern varmeoppsamling. Pass på at ventilasjon ikke hindres ved å unngå å dekke apparatet med ting som aviser, bordduker, gardiner osv.
For å forhindre skade må dette apparatet være godt festet til gulvet/væggen i henhold til installasjonsinstruksjoner.

NO

CZ

OSTRZEŻENIE!

Nie otwierać pokrywy. W środku nie ma części nadających się do naprawy przez użytkownika. Prosimy pozostawić serwis dla wyszkolonego personelu.
Nie umieszczać produktu w pobliżu źródła ciepła, np. grzejnika, lub w bezpośrednim świetle słonecznym, kurzu, czy mechanicznym wibracjom.
Produkt ten nie może być ekspozowany na kąpienie lub chłapanie, a przedmioty wypełnione płynami, takie jak wazy, nie powinny być na nim umieszczone.
Źródła otwartej energii, takie jak np. świece, nie powinny być umieszczone w produkcie.
Należy zapewnić odpowiednią wentylację i unikać blokowania otworów wentylacyjnych, aby uniknąć wewnętrznego wzrostu temperatury. Wentylacja nie powinna być utrudniana poprzez nakrywanie urządzenia gazetami, obrusami czy zasłonami.
Aby uniknąć pokaleczenia, urządzenie musi być bezpiecznie przytwierdzone do podłogi/ściany zgodnie z instrukcją.

PL

DK

ATENÇÃO!

Não abra a tampa. Não tente a reparação do instrumento por si. Dirija-se a pessoal qualificado
Não aproxime a uma fonte de calor excessivo ou exponha o produto à luz solar, poeira, vibração ou choque
Não mantenha o produto num local húmido ou perto líquidos como vasos, etc.
Não aproxime o produto a fontes de fogo vivo, como velas
Mantenha o produto num espaço suficientemente arejado de forma a evitar sobre-aquecimento. Não bloqueie a ventilação do instrumento, cobrindo-o com artigos como cortinas, toalhas de mesa ou jornais
Para prevenir acidentes, recomendamos que fixe este produto à parede ou chão, em conformidade com as instruções de instalação.

PT

NL

VÝSTRAHA!

Neotvárajte kryt. Vo vnútri nie sú žiadne súčasti, ktoré sú opraviteľné užívateľom. S požiadavkou na servis sa obráťte na kvalifikované servisné stredisko.
Nevystavujte produkt do blízkosti akéhokoľvek tepelného zdroja ako napr. radiátora, alebo do kontaktu so slnečným žiarením, nadmerným prašným prostredím, mechanickým vibráciám alebo šokom.
Produkt nesmie prísť do kontaktu s vodou a žiadny objekt naplnený vodou, ako napr. váza, nesmie byť umiestnený na produkt.
Žiadne výrobky s otvoreným ohňom, ako napr. sviečky, by nemali byť umiestnené na produkt.
Umožnite dostatočnú cirkuláciu vzduchu a zabráňte obstrukcii ventilačných otvorov (ak sú prítomné) kvôli prevencii vnútorného prehrievania. Ventilácia nesmie byť narušená prekrytím zariadenia výrobkami ako napr. noviny, kuchyňské uterky, záclony a pod.
Na prevenciu proti zraneniu musí byť toto zariadenie bezpečne pripevnené k podlahe/stene, tak ako je to uvedené v návode na inštaláciu.

SK

FI

OPOZORILO!

Ne odpirajte pokrova. V notranjosti ni nobenih delov, ki jih uporabnik lahko sam popravlja. Popravilo prepusite usposobljenemu oseboju
Ne postavljajte izdelka na lokaciji v bližini vira toplote, kot je radiator, ali na območje, ki je izpostavljeno neposredni sončni svetlobi, pretiranemu prahu, mehanskim tresljajem ali udarcem
Izdelek ne sme biti izpostavljen kapljanju ali brizganju ni nobeni predmeti, napolnjeni z vodo, kot so vaze, se ne smejo postaviti na izdelek
Nobeneaga od virov odprtega ognja, kot so vžgane sveče, se ne sme postavljati na izdelek
Zagotovite zadostno kroženje zraka in umaknite ovire na odprtinah (če obstajajo), zaradi preprečevanja kopičenja notranje toplote. Ventilacija se ne sme ovirati s prekrivanjem naprave s predmeti, kot so časopisi, prti, zavese itn.
Da bi preprečili poškodbe, mora biti ta naprava varno pritrjena na tla/steno v skladu z navodili za namestitev.

SI

FR

¡ADVERTENCIA!

No abra la tapa. No intente reparar el aparato usted mismo. Llévelo a reparar por personal calificado.
No coloque el aparato cerca de fuentes de calor excesivo o donde esté expuesto a luz solar directa, golpes, vibraciones o polvo.
Evite lugares expuestos a humedad. No ponga objetos llenos de líquidos en la superficie de este aparato.
No se deben colocar fuentes de llama desnuda, como velas encendidas, en la superficie de este aparato.
Mantenga suficiente espacio alrededor del aparato para permitir una ventilación adecuada. No obstruya o tape las aberturas con objetos como periódicos, manteles, cortinas, etc.
Para evitar lesiones, este aparato debe fijarse con seguridad al piso o pared de acuerdo con las instrucciones de instalación.

ES

DE

VARNING!

Öppna ej locket. Inga användarvänliga delar inuti. För reparationer vänd er till kvalificerad servicepersonal
Ställ ej produkten inga i värmekälla t.ex element, i direkt solljus, damm, elektronisk vibration eller shock.
Produkten bör ej bli utsatt för droppande eller stänk och inga objekt fyllda med vätskor som t.ex vaser skall ställas på produkten.
Ingen källa till öppna flammor som t.ex tända ljus bör placeras på produkten.
Tillåt tillräcklig luftcirkulation och blockera ej eventuella ventiler för att undvika intern överhettning.
Ventilen bör ej täckas av föremål såsom tidningar, dukar, gardiner etc.
För att undvika skada måste denna produkt vara fäst på golvet eller i väggen enligt instruktionerna.

SE

IT

INTRODUCTION

Thank you for purchasing the SubZero HiCAST S21.
To get the most out of your product,
please read this manual carefully.

BOX 1 CONTENTS

- 1 x Subwoofer with built-in mixer.
- 2 x 6.3mm TS Jack cables.
- 1 x User manual.
- 1 x UK power cable.
- 1 x EU power cable.

BOX 2 CONTENTS

- 2 x Satellite speakers.
- 2 x Satellite speaker stands.
- 2 x Satellite speaker mounting brackets.

PRODUCT FEATURES

- Modular PA system featuring stereo PA or column style PA set-ups.
- Stereo (2.1) or mono (1.1) configurations.
- Built-In eight channel mixer with individual channel EQs and FX send/return.
- Digital media player with USB, SD and Bluetooth connectivity.
- DSP programming featuring 5 professional presets to tailor the sound to your environment.
- 460W RMS, 650W Peak, 1800W Max output power.
- 12" subwoofer containing the built-in mixer.
- Two 5" satellite speakers with stand mounting brackets and stands.
- Powerful Class D amplifier.

OVERVIEW - CONTROL PANEL

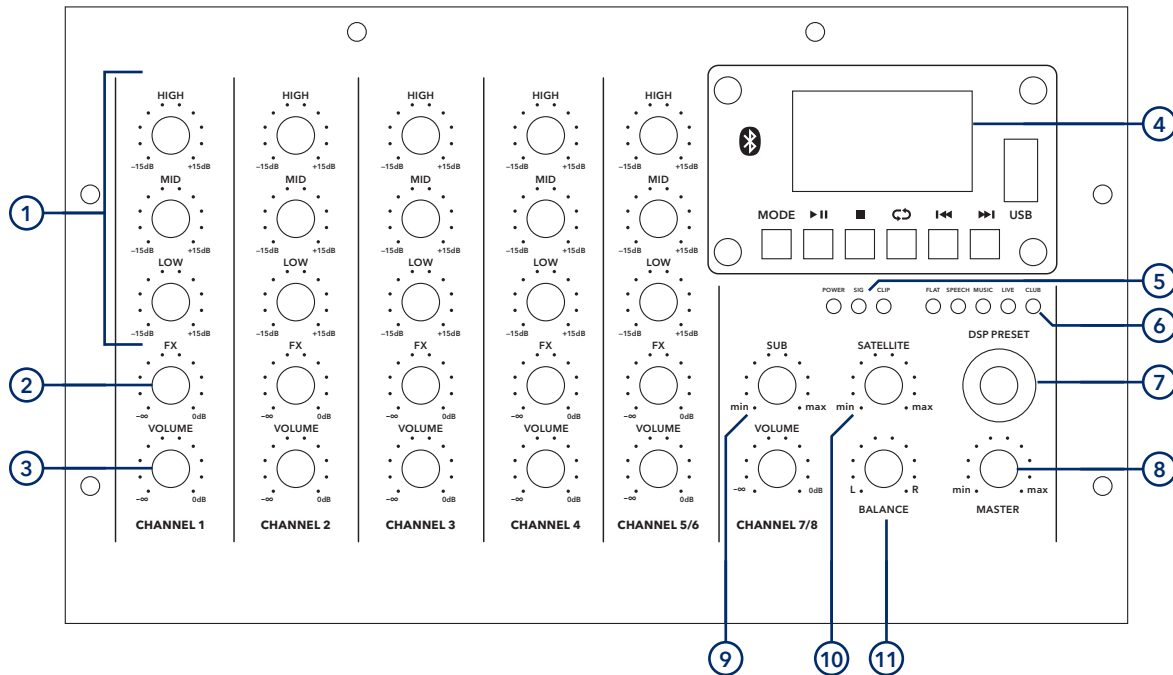

1. EQ CONTROL (CHANNELS 1 - 6)

Controls the EQ for each channel.
 HIGH - Increase or decrease the high frequencies by ± 10 dB.
 MID - Increase or decrease the mid frequencies by ± 10 dB.
 LOW - Increase or decrease the low frequencies by ± 10 dB.

2. FX CONTROL

Controls the amount of FX sent (as received from the FX Return input) to each channel.

3. CHANNEL VOLUME CONTROL (CHANNELS 1 - 8)

Controls the volume of each channel.

4. DIGITAL MEDIA PLAYER

Enables you to play music through the speaker using a variety of platforms. See DIGITAL MEDIA PLAYER section on page 8 for detailed information.

5. LED INDICATORS

POWER - When lit, the power is on.
 SIG - When lit, the speaker is receiving an input signal.
 CLIP - When lit, the input signal level is excessive and should be reduced.

6. DSP SETTING INDICATOR

Displays the current DSP setting.

7. DSP SETTING SELECTOR

Selects the desired DSP setting. Use the dial to scroll through the 5 settings. See page 9 for further details.

8. MASTER VOLUME CONTROL

Increases or decreases the overall output volume for both the subwoofer and speakers.

9. SUB VOLUME CONTROL

Increases or decreases the output volume of the subwoofer.

10. SATELLITE SPEAKER VOLUME CONTROL

Increases or decreases the output volume of the satellite speaker(s).

11. BALANCE

Pans the master output signal left or right.

OVERVIEW - CONNECTOR PANEL

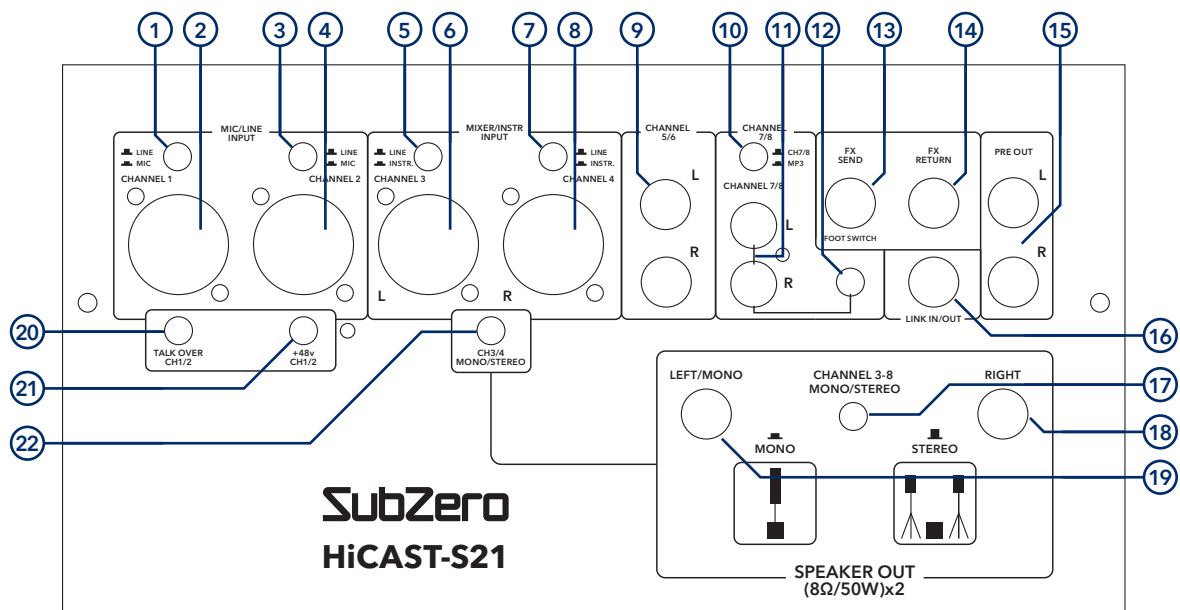

1. CH 1 LINE/MIC SWITCH

Change the input sensitivity to suit either a microphone connection or a line level device connection.

2. CH 1 COMBI INPUT

Connection for an XLR or 6.3mm TRS Jack cable from a microphone or line level device.

3. CH 2 LINE/MIC SWITCH

Change the Input sensitivity to suit either a microphone connection or a line level device connection.

4. CH 2 COMBI INPUT

Connection for an XLR or 6.3mm TRS Jack from a microphone or line level device.

5. CH 3 LINE/INSTRUMENT SWITCH

Change the input sensitivity to suit either an instrument connection or a line level device connection.

6. CH 3 COMBI INPUT

Connection for an XLR or 6.3mm TRS Jack from a microphone or line level device.

7. CH 4 LINE/INSTRUMENT SWITCH

Change the input sensitivity to suit either a microphone connection or a line level device connection.

8. CH 4 COMBI INPUT

Connection for an XLR or 6.3mm TRS Jack cable from a microphone or line level device.

9. CH 5/6 AUXILIARY INPUT

Connection for a stereo pair of 6.3mm TS Jack cables.

10. CH 7/8 AUXILIARY / MP3 SWITCH

Change between the Ch 7/8 Phono Auxiliary Input/3.5mm TRS MiniJack and the Digital Media Player.

11. CH 7/8 AUXILIARY INPUT

Connection for a pair of Phono cables. (Note - You cannot use this connection in conjunction with the 3.5mm TRS MiniJack connection).

12. 3.5MM JACK MP3 CONNECTION

Connection for a 3.5mm TRS MiniJack cable. (Note - You cannot use this connection in conjunction with the Phono connection).

13. FX SEND / FOOT SWITCH

FX Send - Sends the effected signal out.
Foot Switch - Turns the FX send on or off if there is a foot switch inline between the HiCast S21 and an external FX processor.

14. FX RETURN

Receives the signal from an external FX processor.

15. PRE-AMP OUTPUT

Connection for external audio devices. Sends out the master stereo signal, bypassing the amplifier.

16. LINK IN/OUT

Connection to link further HiCAST S21 units.

17. CHANNEL 3-8 MONO/STEREO

When this switch is pressed in, the outputs for channel 3 to 8 are mono summed together. This is useful when the system is in 1.1 mode.

18. RIGHT CHANNEL MASTER OUTPUT

Master output for the right channel in stereo mode.

19. LEFT CHANNEL / MONO MASTER OUTPUT

Master output for the left channel in stereo mode. Main master output in mono mode.

20. TALK-OVER FUNCTION (CH 3-8 ONLY)

When a microphone or instrument is connected to Ch 1 or Ch 2, and the Talk-Over button is pressed, the level of Ch 3-8 will be lowered when a signal is received.

21. +48V PHANTOM POWER (CH 1 + 2 ONLY)

Sends 48v to the input to supply power to condenser microphones.

22. CHANNEL 3/4 MONO/STEREO

When this switch is depressed, the outputs for channel 3 & 4 are summed together. This is useful when the system is in 1.1 mode.

DIGITAL MEDIA PLAYER

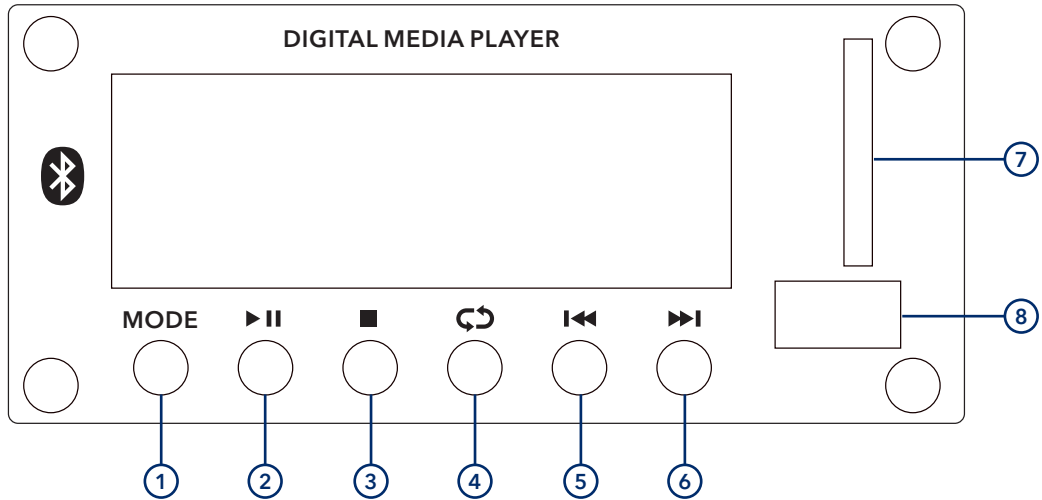

FUNCTIONS

1. MODE

Press this button to scroll between Bluetooth, SD and USB modes.

2. PLAY/PAUSE

Plays or pauses the selected track.

3. STOP

Stops the current track.

4. REPEAT

Press once to repeat the current track. Press twice to repeat all tracks.

5. SKIP TRACK BACKWARDS

Selects the previous track.

6. SKIP TRACK FORWARDS

Selects the next track.

7. SD CARD

Insert SD card here. Formats accepted include MP3, WAV, WMA, AIFF, FLAC.

8. USB

Insert USB device here. Formats accepted include MP3, WAV, WMA, AIFF, FLAC.

BLUETOOTH CONNECTION

To connect a Bluetooth device to the speakers digital media player, please follow the below steps.

- Ensure that the speaker is powered on and within range of the Bluetooth device.
- Press the MODE button on the speakers digital media player until 'Bluetooth' is displayed on the screen.
- Open the Bluetooth settings on the Bluetooth enabled device.
- Scan for Bluetooth devices and search for 'SZ-HiCAST-S21' in the devices list.
- Select 'SZ-HiCAST-S21'. The Bluetooth enabled device should confirm that it is now connected.
- Play audio from the Bluetooth enabled device, ensuring that volume is turned up.
- Turn up the CH7/8 / MP3 volume control on the built-in mixer, ensuring the CH7/8 / MP3 button is pressed in.

DIGITAL SOUND PROCESSING

FLAT



Completely neutral. No DSP processing is applied, so you hear everything exactly as it is.

Examples:

- Using an external audio mixer
- Critical listening in situations where you need to hear unprocessed sound

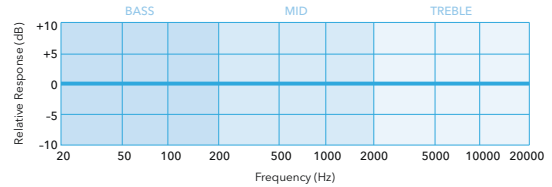

SPEECH



A crisp and clear sound, which aids clarity in presentations and other speech situations.

Examples:

- Presentations in office and classroom environments
- For a public announcement system at an event
- Awards and dinner events
- Amplifying drama and theatre on small stages

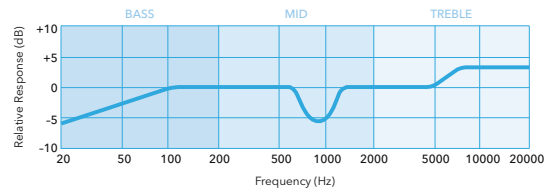

MUSIC



Designed to give energy and brightness to pre-recorded music.

Examples:

- House and garden parties
- Casual listening
- Fitness classes

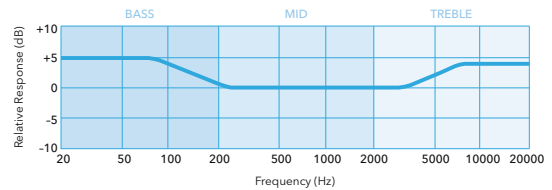

LIVE



Cut through audiences for a pronounced sound, with a slight low-end boost to add 3D depth.

Examples:

- Live gigs, rehearsals and other musical performances
- Singer-songwriters
- Open mic nights

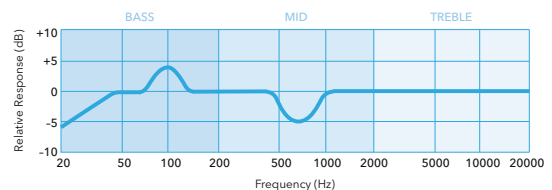

CLUB



Boosts the bass to help drive dance music and enhance your party's atmosphere. Ideal for larger venues.

Examples:

- Mobile DJs
- Children's parties

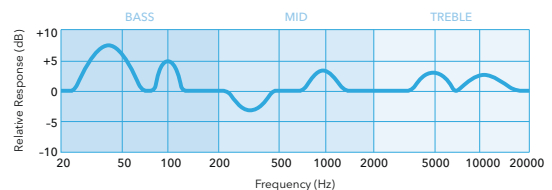

STEREO (2.1) SET UP GUIDE

This mode is suitable for when you wish to use the HiCast S21 as its own standalone PA system, and where you may require a stereo audio image.

SET UP

To help you set up the system properly for a stereo 2.1 format, follow the guide below.

- Slide each of the two 5" speakers on to the two included speaker stands, using the plastic speaker bracket located on the top of the pole.
- Connect a speaker jack cable from the "LEFT/MONO" output on the subwoofer to the jack socket on the base of the speaker bracket situated to the left of the subwoofer.
- Connect a speaker jack cable from the "RIGHT" output on the subwoofer to the jack socket on the base of the speaker bracket situated to the right of the subwoofer.
- Ensure that the "CHANNEL 3-8 MONO/STEREO" switch (fig 17, page 5) is unpressed when using this mode.

USING THE INTERNAL MIXER IN 2.1 MODE

The HiCast S21 internal mixer has been laid out in a very flexible manner, allowing for a full band set up regardless of which device you wish to plug in. Below is a guide for each channel and how best to utilise the system.

Channel 1 and 2 are specifically designed for 'centre stage' devices, such as vocal microphones, or instruments requiring line level inputs. These two channels are mono summed, meaning that they will output from both satellite speakers, regardless of your set up. These two channels have +48v phantom power functionality, allowing you to connect condenser microphones straight to the unit.

Channels 3 and 4 are suitable for high-Z instruments (such as keyboards) or line level audio devices. Different to channels 1 and 2, these two channels can be used in stereo (channel 3 outputs to left speaker, channel 4 outputs to right speaker) or can be mono summed (both channels output

to both speakers). This allows you to input two different devices (MONO) or left and right inputs from the same device (STEREO). To toggle between mono or stereo options, simply press the CH 3/4 MONO/STEREO button on the connector panel.

Channels 5 to 8 are all stereo channels, meaning that channels 5 and 7 will output to the left speaker and 6 and 8 will output to the right speaker. Should you wish to sum all these channels, this can be done by pressing the CHANNEL 3-8 MONO/STEREO button. However, do note that this will also override channels 3 and 4, meaning you would lose the stereo image for these two channels.

USING EXTERNAL MIXERS WITH 2.1 MODE

It is strongly advised to use either channels 3 and 4, channels 5 and 6, or channels 7 and 8 (depending on the desired connector) when connecting from an external mixer. This will enable a left and right stereo image to be presented without any signals being mono summed. When using this feature, ensure that the CH3/4 MONO/STEREO and the CHANNEL 3-8 MONO/STEREO buttons are released, and if using channel 3 and 4, ensure the INSTR/LINE switch is set to LINE.

MONO (1.1) SET UP GUIDE

This mode is suitable when you have limited space or if you would like to use the system as a column PA. This set up only requires one speaker cable connection, allowing for a simpler cable solution. Do note, in 1.1 mode, all output signals to the satellite speakers are mono summed, meaning you will not have a stereo signal.

SETUP

To help you set up the system properly for mono 1.1 format, follow the guide below.

- Remove the pole from one of the speakers stands to reveal a threaded end on the pole. This should be screwed in to the threaded socket on the top of the subwoofer.
- Slide one 5" speaker on top of the other, using the sliding mechanisms.
- Slide the two 5" speakers on to the plastic speaker bracket located on the top of the pole.
- Connect a speaker jack cable from the "LEFT/MONO" output on the subwoofer to the jack socket on the base of the speaker bracket.
- Ensure that the "CHANNEL 3-8 MONO/STEREO" switch (fig 17, page 7) is pressed in when using this mode.

USING THE INTERNAL MIXER IN 1.1 MODE

Connect any combination of microphones, instruments or line level devices in to channels 1 to 8, ensuring that the MIC/LINE and INSTR./LINE switches are set to the appropriate levels, and that the +48v switch is pressed if you are using microphones requiring phantom power.

USING EXTERNAL MIXERS WITH 1.1 MODE

Connect the left and right outputs from the external mixer to any of the inputs on the HiCast S21 (depending on desired connection), however ensure that any MIC/LINE or INSTR./LINE switches are set to "LINE".

SPECIFICATIONS

Amplifier	Class D DSP
RMS Power(total)	300W + 80W + 80W
Max Power	1200W + 320W + 320W
Subwoofer	1x12" woofer, 2"VC, 80 oz ferrite magnet
Speakers	5" woofer with 1" neodymium tweeter
Impedance (total)	4 Ohm
Sensitivity	96dB
Max SPL rating	126dB
Frequency response	55Hz-20KHz
Power Consumption	500W
Fuse Type	6.35A (110-120V) / 3.15A (220-240V)
AC power input	110-120V / 220-240V
Weight	11.42kg (speaker) / 22.96kg (subwoofer)
Dimensions	155*147*270mm (speaker) / 480*380*450mm (subwoofer)

KETTLESTRING LANE | YORK | YO30 4XF | UNITED KINGDOM
METALLVÄGEN 45A | 195 72 ROSERSBERG | STOCKHOLM | SVERIGE
LAHNSTRASSE 27 | 45478 MÜLHEIM AN DER RUHR | DEUTSCHLAND

If you have any more questions about this product, please do not hesitate to contact the Gear4music Customer Service Team on: **+44 (0) 330 365 4444** or **info@gear4music.com**