



d16 group
AUDIO SOFTWARE

SYNTORUS2

TRIPLE PATH ANALOG CHORUS



User Manual

Requirements

Software and hardware requirements:

Windows PC

OS version	Windows 7, Windows 8, Windows 10
CPU	2.5 Ghz with SSE (System 2.8 Ghz recommended)
RAM	8 GB (16 GB Recommended)
Software	VST / AAX compatible host application (32bit or 64bit)

Mac OS X

OS version	OS X 10.7 to 10.14
CPU	Intel based 2.5 Ghz (2.8 Ghz recommended)
RAM	8 GB (16 GB Recommended)
Software	AU / VST / AAX compatible host application (64bit)

Overview

Syntorus 2 is an analogue-style chorus effect based on a triple **BBD** (*Bucket Brigade Device*) delay line, and featuring three freely configurable **LFOs**. Upon loading the plug-in in any **VST**, **Audio Units** or **AAX** host application, the GUI appears:



Syntorus 2's graphical interface

The interface comprises two main sections:

- **Configuration and preset management** (the top-most section)

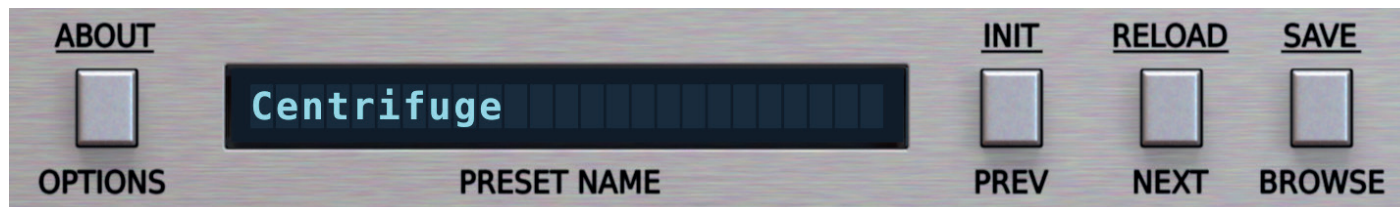

The configuration and preset management section

- **Signal processing** (all other controls)

Signal flow

In this chapter, we'll describe the signal path through **Syntorus 2**, and explain each component and its controls along the way.

Basic modules

Each of the four modules that make up **Syntorus 2** is housed within its own section in the GUI:

- **Line** – Controls for the three **Delay Lines**.
- **LFO** – Controls for the three **LFOs**.
- **Mixer** – Controls for blending and panning the three **Delay lines**.
- **Master** – Controls for routing the **LFOs** to the **Delay Lines**, activating **BBD mode**, and adjusting the **Dry/Wet mix** and final **output level**.

Delay Line section

Syntorus 2 features three BBD Delay lines, the parameters of which are adjusted in the **Line** section of the interface.



The Line section

To switch the visible controls to any of the three delay lines, click the **Line 1, 2 or 3** LED in the section's header bar.



Click the Line 1, 2 and 3 LEDs to switch between Delay Lines

A single delay line is governed by the following parameters:



The Delay Line parameters

- **Offset** – The base (minimum) time by which the input signal is delayed, expressed in *milliseconds*, from 0 – 20 ms.
- **Depth** – The maximum amount of delay time modulation applied by the assigned **LFO(s)**, expressed in *milliseconds*, from 0 – 20 ms. Therefore, delay time modulation ranges from **Offset** (minimum) to **Offset + Depth** (maximum).
- **Tremolo** - Applies a tremolo effect (amplitude modulation) to the **Delay Line's** output.
- **Filter** – Select the type of filter inserted into the **Delay Line's** output.
 - **Off** – Disables the filter
 - **Low Pass** – Attenuates all frequencies above the cutoff frequency
 - **High Pass** – Attenuates all frequencies below the cutoff frequency
 - **Band Pass** – Attenuates all frequencies above and below a narrow range centred on the cutoff frequency
- **Cutoff** – Controls the filter cutoff frequency.
- **Modulation** – Sets the depth of cutoff frequency modulation by the assigned **LFO(s)**.

The **Depth**, **Tremolo** and **Modulation** parameters determine the amount of delay time (**Depth**), filter cutoff (**Modulation**) and amplitude (**Tremolo**) modulation applied by the **LFO** or **LFOs** assigned in the **Configuration** panel, described later.

SIGNAL FLOW •

The diagram below shows the signal flow through a single Delay Line:

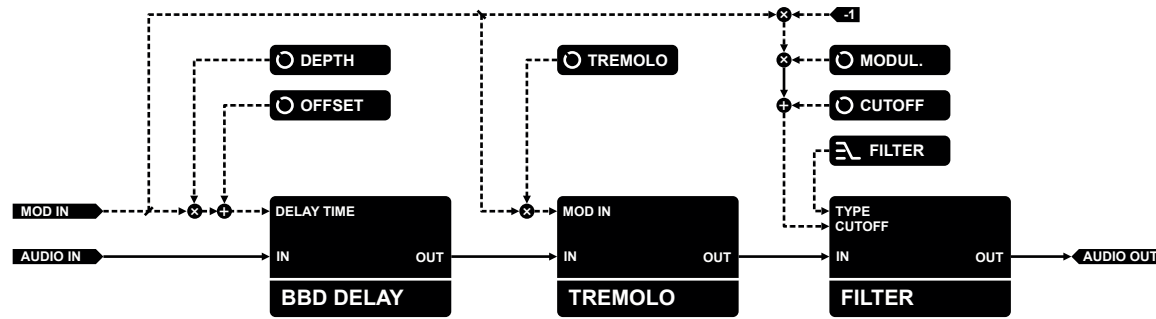

The signal flow through a single Delay line

LFO section

Syntorus 2's three LFOs are used to modulate each Delay Line's delay time, filter cutoff and amplitude. They're individually adjusted in the LFO section.



The LFO section

To select an **LFO** generator for editing, click the **LFO 1, 2** or **3** LEDs in top bar of the section.

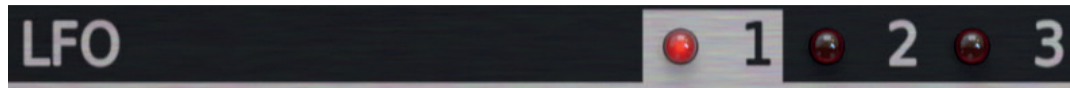

Switch between LFOs by clicking the LFO 1, 2 and 3 LEDs

All three **LFOs** share the same set of parameters:

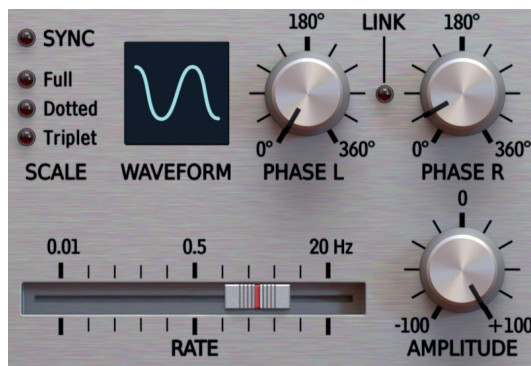

Parameters for a single LFO

- **Rate** – Controls the cycle frequency of the **LFO**, from 0.01 – 20 Hz.
- **Waveform** – Selects the **LFO** waveform: *Sine, Triangle, Hyper Triangle, Ramp Down (sawtooth), Square* or *sample + hold*.
- **Amplitude** – Governs the amplitude of the oscillations. When set in the negative range, the waveform is inverted.
- **Phase L / Phase R** – Shift the oscillator phase for the *Left* and *Right* channels independently.
- **Sync** – Activate to sync the **LFO** to the clock/tempo of the host application. The **Rate** slider scale will change from *Hz* to musical note values, and three note type modifiers are available:
 - **Full** – The **LFO**'s cyclical period length is equal to the full note value set by the **Rate** slider at the host tempo.
 - **Dotted** – The **LFO**'s cyclical period length is equal to the dotted note value set by the **Rate** slider at the host tempo.

Each channel / column in the mixer represents a single **Delay line**, and all three channels share the same controls:

- **VU Meter** – Shows the output signal level for the **Delay Line**.
- **Pan** – Controls the *left / right* balance of the **Delay Line**.
- **Vol** – Controls the output volume level of the **Delay Line**.

Master section

The final stage governs the **Output Volume** and **Dry/Wet** mix, **LFO** routing and **BBD Emulation** mode.



Master section

- **Configuration** – Sets the routing scheme for assigning the three **LFOs** to the three **delay lines**. Three topologies are available:

- **Independent** – Each **LFO** is assigned to its respective delay line (**LFO1** to **BBD1**, **LFO2** to **BBD2**, and **LFO3** to **BBD3**)

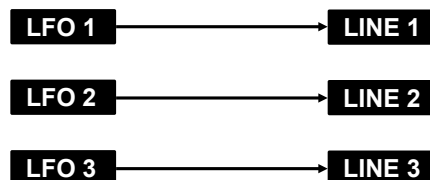

- **Summed** – The three **LFO** output signals are summed and routed to all three delay lines

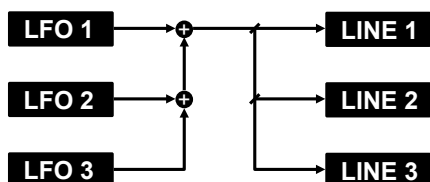

- **Mixed** – the signals from **LFOs 1** and **2** are summed and routed to **Lines 1** and **2**. **LFO 3** is routed to **Line 3**

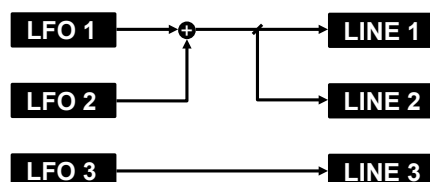

- **Analog BBD Emulation** – Syntorus 2's discrete-time analogue **BBD** (*Bucket Brigade Device*) delay line delivers an „ideal“ clean emulation by default, but activating **Analog BBD Emulation** delivers a warmer and even more authentic analogue sound, at the expense of greater system overhead.
- **FX** – Sets the proportional balance of unprocessed and processed signal at the final output.
- **Output volume** – Controls the final amplification level.

Path of the signal's flow

The diagram below shows the signal flow through Syntorus 2:

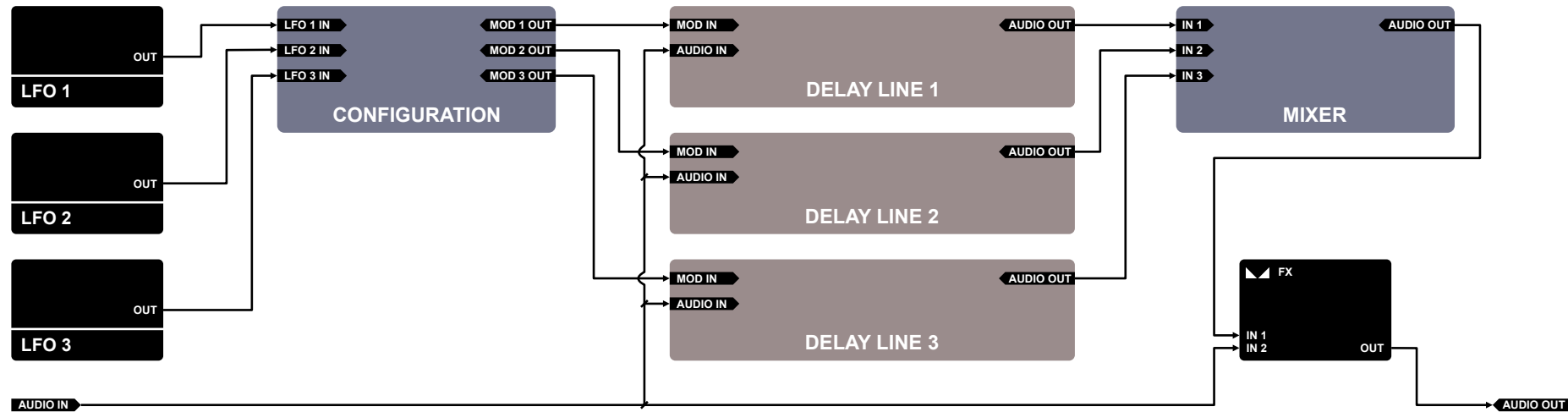

Syntorus 2 signal flow

Preset Management

Preset Storage

Presets – both those in the **Factory** library and those made by the **User** – are stored as files in specific folders on your hard drive. Every time the plugin is loaded, these folders are scanned and the presets they contain are consolidated in a linear structure in the **Preset Browser**.

Browsing Presets

The **Presets configuration and management** section enables easy navigation and browsing of the preset library.

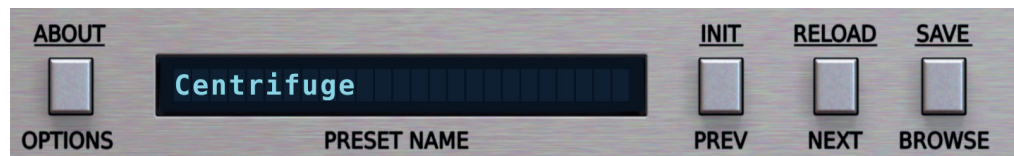

Presets Configuration and Management Section

- **PRESET NAME** – Displays the name of the currently loaded preset.
- **PREV / NEXT** – Step backwards and forwards through the preset list (depending on the currently set filters – see below).
- **INIT** – Win (**Ctrl**) + **PREV**), Mac (**Cmd** + **PREV**) – Restore all plugin parameters to their initial settings.
- **RELOAD** – Win (**Ctrl**) + **NEXT**), Mac (**Cmd** + **NEXT**) – Restores parameters from the most recent checkpoint, which is re-initialization, loading a preset or loading a project (total recall).

- **SAVE** – Win (**Ctrl** + **BROWSE**), Mac (**Cmd** + **BROWSE**) – Save the current parameters as a new preset or overwrite the existing one (see below).
- **BROWSE** – Fold the **Preset Browser** panel out from the bottom of GUI.

The **Preset Browser** looks like this:



Preset Browser

One can see three main sections:

- **Content** – The available preset resources.
- **Filters** – View only certain categories or types of presets (inactive by default).
- **Results** – The list of presets that meet the criteria set by the **Filters**.

Content

Select preset resources for browsing. There are two resources available:

- **Factory** – The presets that are included with the plugin. **Factory** presets are read-only (ie, they can't be overwritten).
- **User** – Presets created by the user. **User** presets can be freely modified, backed up as files, shared with others, etc.

Selecting a single **Content** resource narrows the filtered preset list down to presets from that resource only.

Preset Filters

The browser enables classification of presets through the use of **Categories** and **Tags**, in order to facilitate filtering of the **Results** list.

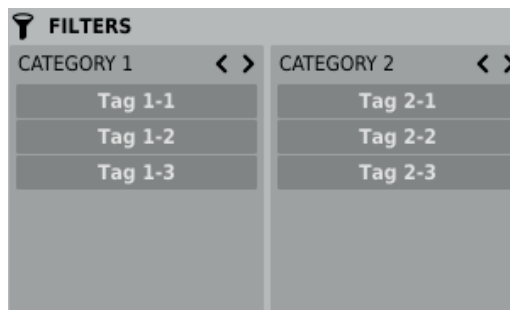

Preset Browser Category Filters

Categories and Tags

Each preset is assigned to one or more of a few common **Categories**. Within each **Category** there may be one or more **Tags**.

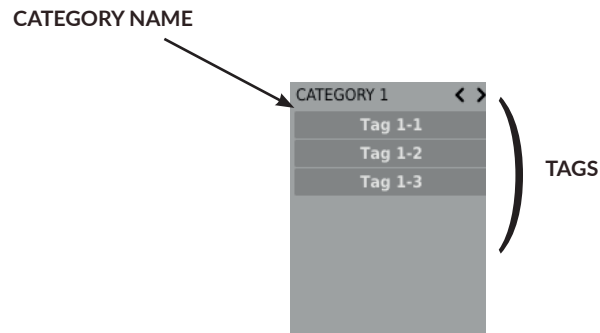

A single Category in a Filter with three Tags

The **Factory** presets come with **Categories** and **Tags** already assigned. These have been chosen to specifically describe the sounds and characteristics of those presets as representatively as possible, taking into account the remit of the plugin.

The **Categories** and **Tags** assigned to the **Factory** presets can't be edited. **User** presets, however, can be given **Categories** and **Tags** from the factory content, and you can also define your own custom **Tags**.

Results

The list of presets from the selected **Content** resources that meet the filtering criteria is displayed in the **Results** section. This is where the actual browsing and loading of presets is done (in the default **Browsing Mode**).



The Results section in the Preset Browser

Click the name of a preset to select and load it.

Double-click a preset to enter preset name edit mode. ▶

Presets Filtering

The columns in the **Filters** section represent particular **Category filters**, while the rows in each of these columns represent the **Tags** available within each **Category**.

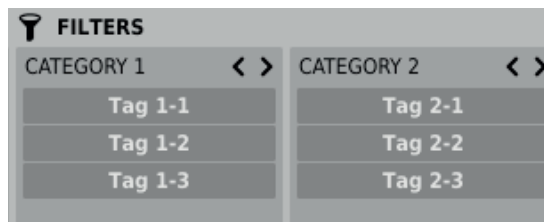

Preset Browser Category Filters

The **Filters** cascade through the columns, from left to right: all presets in the selected Content resources are filtered according to the **Tags** in the first **Category** (the first column from the left), the remaining presets are then filtered by the **Category** represented by the second column, etc, up to the last active **Category Filter**.

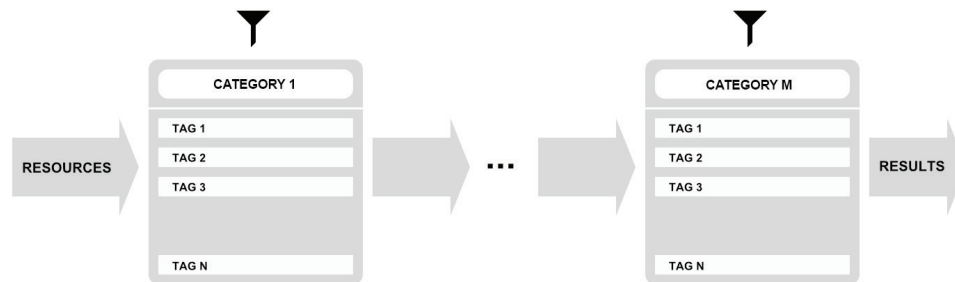

Preset Filtering with Category Tags

The result of this cascaded filtering process – ie, only the presets that meet the criteria of every active filter – is listed below, in the **Results** section.

Basic Actions on Filters

The **Tag** buttons in a **Filter** toggle between active and inactive when clicked: a grey **Tag** is inactive, and a teal blue **Tag** is active. A **Filter** is only active when at least one **Tag** in a column (**Category**) is active.

For example, if the first column in the illustration below represents the *Category 1 Category*, containing the *Tag 1-1*, *Tag 1-2* and *Tag 1-3 Tags*, clicking the *Tag 1-1 Tag* will activate the **Category Filter Category 1**, and narrow the preset list down to only the presets assigned the *Tag 1-1 Tag* in the *Category 1 Category*.

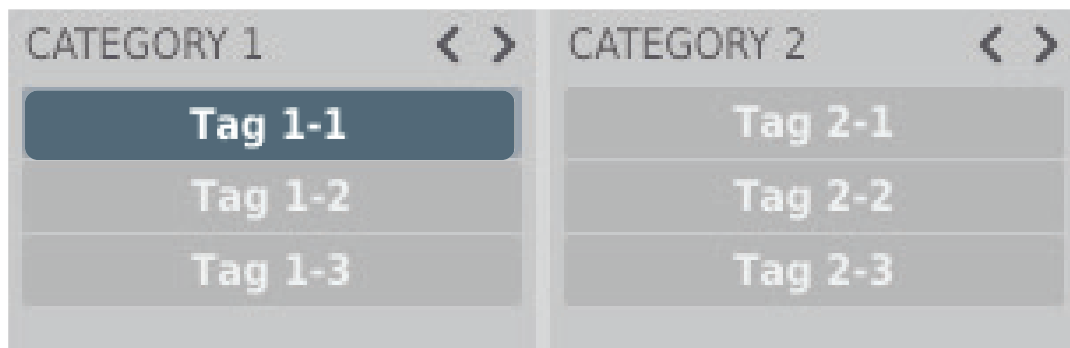

Enabling the 'Tag 1-1' Tag in the 'Category 1' Category

Clicking the *Tag 1-1 Tag* again deactivates the **Filter**, so that all presets from the selected **Content** resources are displayed again.

Reordering Categories

To the right of the **Category Filter** header are two arrow buttons:



Filter reordering

These move the **Category** left or right in the cascade. Clicking the right arrow swaps the current **Category** with the **Category** to the right; clicking the left arrow swaps the current **Category** with the **Category** to the left.

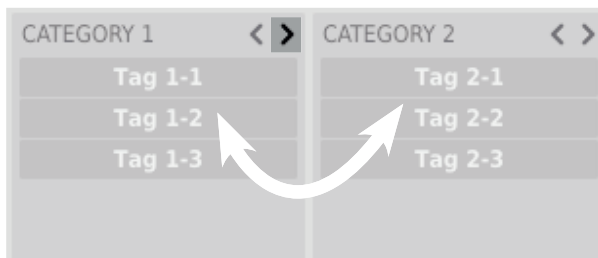

Presets Filtering with the Use of Categories Tags

Clicking the left arrow for the left-most **Category**, or the right arrow for the right-most category, does nothing, as the column has no predecessor/successor with which to swap.

Presets editing - Edit Mode

Activating **Edit Mode** in the **Preset Browser** enables the editing of preset names, **Categories** and **Tags**, as well as the deletion, export and import of presets. Note that these operations are only permitted for **User** presets, not **Factory** presets.

Enter and exit **Edit Mode** using the button in the bottom left-hand corner

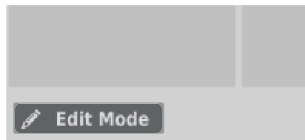

The Edit Mode button

In **Edit** mode, the **Preset Browser** changes in appearance and function:



The Preset Browser in Edit Mode

1. The **Filters** section changes becomes the **Edit Tags** section, which looks almost identical but is used to change – rather than operate – the **Categories** and **Tags** of the selected presets.
2. Presets (**User** only – not **Factory**) are selected for editing in the **Results** section.
3. The **Delete**, **Export** and **Import** buttons at the bottom of the interface are used to delete or export selected **User** presets, and import a set of presets to the **User Content** resource.
4. The resource selection in the **Content** section can't be changed, as editing is only possible for user presets.

Selection of presets for editing

You can edit presets one at a time or in groups. Select one or more presets in the **Results** section using the following procedure:

- **Click a preset** – Choose the preset from the list,
- **Win (ctrl + Click a preset), Mac (cmd ⌘ + Click the preset)** – Add another preset to the selection.
- **shift + Click a preset** – Select a contiguous series of presets from the last one selected to the one clicked.

Editing Tags

Changing the Tags assigned to the selected preset(s)

With one or more presets selected, click a **Tag** button to assign it, or unassign it if already assigned.

User	Tag 1-1	Tag 2-1
	Tag 1-2	Tag 2-2
	Tag 1-3	Tag 2-3

Filters' tags

Selecting multiple presets with **Tags** assigned enables those **Tags** to be edited. If a particular **Tag** is assigned to *all* selected presets, it's marked with an intense teal blue color.

When a particular **Tag** is only assigned to *some* of the selected presets, it's given a pale teal blue colour.

All **Tags** that don't appear in *any* of the selected presets are coloured grey.



Colouring of Tags by status for selected presets

Changing the **Tag** status for one selected preset changes it to the same status for *all* selected presets. The change of status is indicated by an asterisk (*) to the left of the **Tag** buttons.



Notification of changes to the Tag status of selected Presets

User edits don't have to be confirmed. They're indicated by asterisks next to the edited **Tag**.

Preset name editing

Double-click the name of a preset to enter name editing mode.

Deleting presets

Selecting one or more presets invokes the **Delete** button at the bottom left corner. Click this to delete the selected presets.

Preset export and import

Use the **Export** and **Import** buttons at the bottom of the **Preset Browser** to export the presets selected in the **Results** section as a package, or import a previously exported package into the Preset library.

Saving the current settings as a preset

To save the current plugin parameter settings as a **User** preset click **BROWSE** in the **Configuration and Presets Browsing** section while holding -Win (**Ctrl** + **BROWSE**), Mac (**Cmd** + **BROWSE**) in **Configuration and Presets Browsing** section. The **Preset Browser** will automatically open in **Edit Mode**.



Saving the settings as a preset

Enter a name for your newly created preset in the text field at the bottom, then confirm it by clicking **Save**, or back out of the process by clicking **Cancel**.

As the **Preset Browser** automatically enters **Edit Mode**, you can immediately categorize the preset using the **Edit tags** functions before saving it.

Configuration

Parameter settings

Right-click any plugin parameter to open its contextual menu.

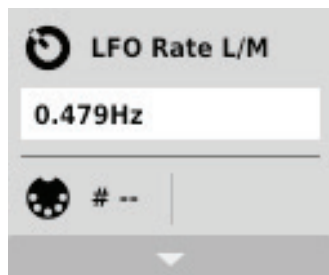

Closed contextual menu

Using this, you can:

- Check the name and current value of a parameter,
- See whether or not the parameter has been assigned a MIDI CC number, and if so, which one,
- Link the parameter to a MIDI CC number.

Clicking the arrow strip at the bottom of the menu expands it to display all available options. Right-clicking the parameter again or left-clicking outside the menu area closes the contextual menu.

MIDI Learn

The **MIDI Learn** function enables quick assignment of physical MIDI controllers to plugin parameters. An assignment is made by following this procedure:

1. Right-click the parameter you want to assign to your hardware MIDI controller. The contextual menu opens.
2. Click the arrow strip at the bottom to expand the contextual menu.

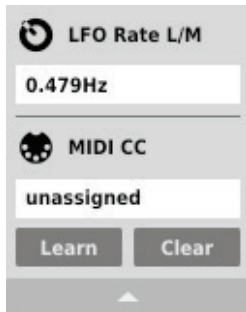

Expanded contextual menu

3. Click the **Learn** button to put the plugin into a pending state, awaiting MIDI CC input from your hardware MIDI controller
4. Move the relevant knob or slider on your MIDI controller to make the assignment
5. Click **OK** to save the change or **Cancel** to restore the previous setting

MIDI Unlink

To delete the MIDI CC assignment for a plugin parameter:

6. Open the contextual menu by right-clicking the parameter in question
7. Expand the menu by clicking the arrow strip at the bottom
8. Click the **Clear** button
9. Confirm with **OK** button

Current settings

The **Current settings** are applied separately to each instance of the plugin but initialized with the **Default settings** when the plugin is loaded (see next chapter).

The **Current settings** are adjusted in the status bar at the bottom of the interface.



The Current settings in the status bar

From left to right, they comprise:

- The **Current processing path quality** for **Offline** and **Real-time** modes
- Saving/Loading of the **MIDI CC Map**
- A choice of two **GUI** sizes

Processing Path Quality

Set the **Current quality** of the plugin's generated output for **Real-time** and **Offline** modes.

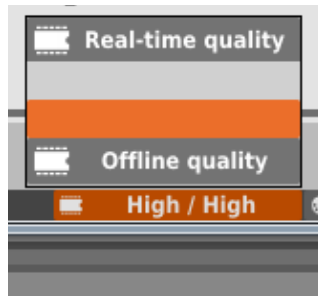

Choosing the plug-in interface size

There are few quality levels available for each mode.

MIDI CC Map

Save all current MIDI CC parameter assignments as a MIDI Map file, or load an existing MIDI Map file into the plugin.

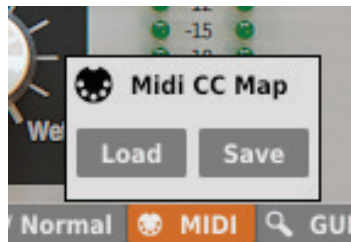

Saving/loading the MIDI CC Map

GUI size

Switch the graphical user interface between few different sizes.



Choosing the plug-in interface size

Default settings

Change the **Default settings** of the plugin in the **Options** panel. The **Current settings** of every new instance of the plugin are initialized to the **Default settings**.

The **Default settings** are stored in a configuration file. This file is updated every time you close the **Options** window.

Open the **Options** panel by clicking the **Options** button:

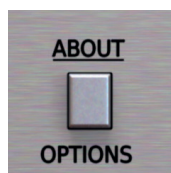

Options button

The **Options** panel is made up of four sections, only one of which can be expanded at a time.



Options Panel

The four sections are:

- **Processing Quality** - The default Processing Path quality
- **Presets** - The preset loading warning dialog status
- **MIDI** - The default MIDI CC Map
- **User Interface** - The default GUI size

Processing Quality

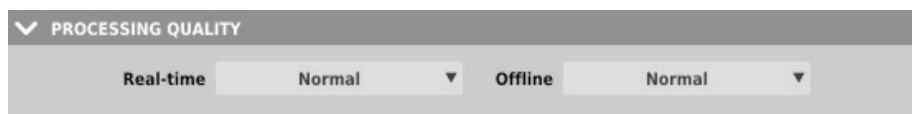

Processing Quality Choice Section

In this section, you can configure the default quality of the processing path for the **Real-time** mode and **Offline** modes.

MIDI

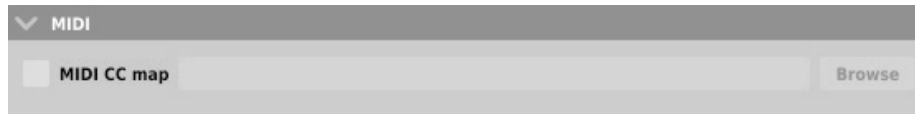

Default MIDI Map Choice Section

Set the path to a default **MIDI Map** file. Clicking the **MIDI CC Map** checkbox ‘unlocks’ the **Browse** button and activates the selected MIDI Map.

User Interface



Default size of User Interface

Choose one of several default GUI sizes to best match the plugin to the resolution of your computer monitor.

Presets

PRESETS

If parameters were changed show warning before loading Prev/Next preset

Displaying confirmation dialog option

With the box checked, clicking the **Prev** or **Next** preset button after the parameters of the current preset (or previously initialized state) have been changed pops up a confirmation dialog to prevent accidental loss of those changes.

CONTENTS

Requirements.....	2	Changing the Tags assigned to the selected preset(s)	22
Overview.....	3	Preset name editing.....	24
Signal flow	5	Deleting presets	24
Basic modules.....	5	Preset export and import	24
Delay Line section.....	6	Saving the current settings as a preset	25
LFO section.....	8	Configuration	26
Delay line mixer.....	10	Parameter settings.....	26
Master section.....	11	MIDI Learn.....	27
Path of the signal's flow.....	13	MIDI Unlink.....	28
Preset Management	14	Current settings.....	28
Preset Storage.....	14	Processing Path Quality.....	29
Browsing Presets.....	14	MIDI CC Map.....	29
Content	16	GUI size	30
Preset Filters	16	Default settings	30
Categories and Tags.....	17	Processing Quality	31
Results	17	MIDI	32
Presets Filtering.....	18	User Interface	32
Basic Actions on Filters	19	Presets	33
Reordering Categories	20		
Presets editing – Edit Mode	20		
Selection of presets for editing.....	22		
Editing Tags	22		