



# PLATINUM II IN-CEILING SPEAKER



## PLIC II IN-CEILING SPEAKER

### No compromise' flagship speaker system

The Monitor Audio PLIC II in-ceiling speaker offers unsurpassed levels of performance, delivering sublime audio accuracy. Providing a winning combination of high quality sound, ease of installation and discreet design, this discreet speaker will be a firm favourite with home technology installers, architects, interior designers and end users.

### Unsurpassed levels of performance

The Monitor Audio PLIC II in-ceiling speaker features an 8" long throw bass driver with Rigid Diaphragm Technology (RDT II) cone technology to provide immensely powerful bass lines. This is achieved by the RDT cone reacting to an audio signal with lightning fast precision without deformation. To provide the listener with a uniform frequency spectrum when the speaker is played at higher frequencies, additional dual mid-range drivers that feature C-CAM cone technology and Monitor Audio's new Micro Pleated Diaphragm (MPD) transducer are mounted on a rigid aluminium baffle and directed towards the listening zone provide uniform mid and high frequency dispersion.

To ensure controlled audio performance, Monitor Audio has designed an MDF back box with pre-determined air volume of 24L. The rigid box is available with pre-loaded internal damping material to provide the best possible sound absorption and reduce standing waves.

All PLIC II drivers employ a heavy duty motor system, which deploys an under-hung motor assembly to ensure the coil always remains in the gap, even when driven hard. The addition of copper 'shorting' rings greatly improves magnetic linearity and lowers intermodulation distortion, resulting in crisp and clear audio delivery. A world first for an in-ceiling speaker!

### Easy to install and maintain

Designed for installation in both new build and retrofit projects, the PLIC II in-ceiling speaker features Monitor Audio's unique Tri-Grip fixing system. This 3-position 'dog leg' style fixing provides a greater contact surface area than other types. This system, combined with the magnetic grille, saves the installer both time and money by speeding up the speaker fitting process.

### Designer friendly

To satisfy the interior designer and end user, the circular grille can appear almost invisible, by being painted to match the room décor. Monitor Audio also offers a square grille option to match lighting fixtures and ventilation.



## PLIC II IN-CEILING SPEAKER

### Technology

- High-performance 'no compromise' flagship speaker product
- Compact dimensions
- 4 drivers – full three-way design
- 8" Long throw Bass driver featuring RDT II cone technology
- Dual 2" C-CAM mid-range drivers for wider dispersion
- MPD high frequency transducer
- Angled mid-range and high frequency drivers – directed towards listening area to provide uniform mid and high frequency dispersion
- Rigid aluminium baffle construction
- Highest quality 'push' style termination
- Mid-range and H.F level adjustment switches (+1/0/-1) dB
- Paintable, trim less/low profile circular magnetic grille design – square options available
- Highest quality crossover design – including metallised polypropylene capacitors and low loss inductors
- Patented Tri-grip dog leg fixing
- PLIC-BOX II – specially designed pre-construction enclosure provides ideal controlled performance.
- Pre-construction bracket for retro fit purposes -CB10 (light brown)

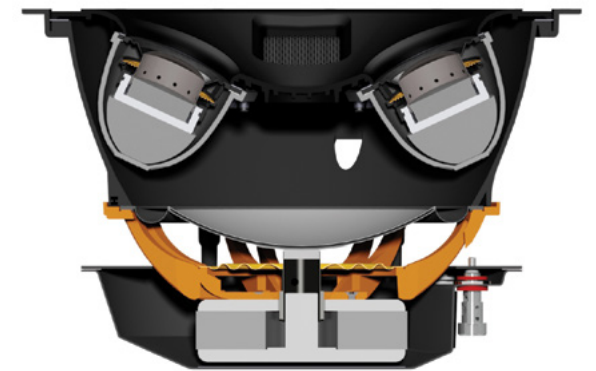
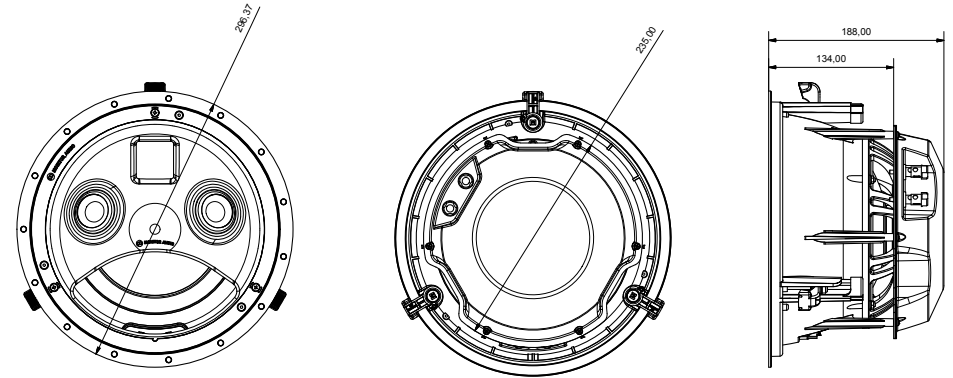



## Specifications

	Platinum II In-Ceiling
System Configuration	4 driver,3-way
Frequency Response (-6db)	45Hz - 60kHz
Sensitivity (1W@1M)	90 dB
Impedance	4 Ohms Nominal (3.1 Ohms Minimum @1.1KHz)
Maximum S.P.L (@1M - each)	112 dBA
Power Handling	150 W (R.M.S)
Recommended amplifier requirements	50-150 W (R.M.S)
Recommended Enclosure	PLIC-BOX II or A bespoke sealed enclosure of 24 Litres
Mid/ H.F Crossover Frequency (Hz)	5.3KHz 3rd Order (18dB/Octave)
Bass/Midrange Crossover Frequency (Hz)	380 Hz/4th Order 24dB/Octave)
Drive unit Complement	1 x 8" long-throw RDTII bass driver 2 x 2" C-CAM mid-range drivers 1 x MPD high frequency transducer
Adjustment controls	H.F level switch (+1dB/0dB/-1dB) M.F Level switch (+1dB/0dB/-1dB)
Cable Connection	High-end 'Push' type terminals
Fixings	3 position Tri-Grip Dog leg fixings
Overall Diameter - Grille on	309mm (12 <sup>3</sup> / <sub>16</sub> Inches)
Grille off	296.25mm (11 <sup>11</sup> / <sub>16</sub> Inches)
Overall Depth – Grille on	191.5mm (7 <sup>1</sup> / <sub>2</sub> Inches)
Grille Off	188mm (7 <sup>3</sup> / <sub>8</sub> Inches)
Pre- Construction bracket	CB10 (Light Brown)
Construction Material	Main chassis - Mineral Filled ABS (RoHS2 compliant) Baffle – Die cast Aluminium
Grille type	Low profile trim less grille with magnetic fixings – Paintable (Square grille available as a cost option)



Monitor Audio Ltd  
24 Brook Road,  
Rayleigh, Essex,  
SS6 7XJ England  
T. + 44 (0)1268 740580  
F. + 44 (0)1268 740589  
E. info@monitoraudio.co.uk

monitoraudio.com