



# Q Acoustics Concept range

## No artificial colouring

Q Acoustics introduces the newest models of its award-winning series of Concept stereo and home cinema loudspeakers. Taking cutting-edge acoustic technology and design cues pioneered in the flagship Concept 300 and 500, while also introducing new state-of-the-art audio innovations, the new Concept 30 standmount, Concept 50 floorstanding and Concept 90 centre channel models deliver truly high-end home audio performance without spending high-end money.



**Concept 30**  
Standmounting speaker  
£899



**Concept 90**  
Centre speaker  
£649



**Concept 50**  
Floorstanding speaker  
£1,999

Every element of acoustic innovation featured in the latest Concept range is geared towards designing the quietest cabinet possible. Unaffected by internal and external resonances, these speakers deliver focused stereo imaging, accurate audio and an extended holographic soundstage to emulate a live performance in the home.

**Audio innovations include:**

- Gelcore™ cabinet construction reduces higher frequency cabinet noise.
- Point-2-Point™ (P2P) internal bracing stiffens the cabinet to minimise lower frequency vibrations.
- Helmholtz Pressure Equalisers (HPE™) reduces internal pressure and standing waves (Concept 50 only).
- Isolation suspension base eradicates unwanted external and internal vibrations.

**New audio innovations include:**

- The drive units are fixed to a highly stiff, 3mm thick, damped aluminium baffle plate. Pre-tensioned studs, extending from the back of the drive unit chassis, pass through the stiff P2P cross braces and provide the fixings for the baffle assembly.
- Ground-up mid/bass and tweeter driver design for increased power handling.
- High-frequency driver is fully hermetically sealed and mechanically isolated (floating) from the front baffle to protect from internal resonances from the mid/bass driver.
- Crossover design is mounted on the isolation base, to minimise any microphonic pick up and away from electro-magnetic fields radiated by the drive units.



## Technical specifications

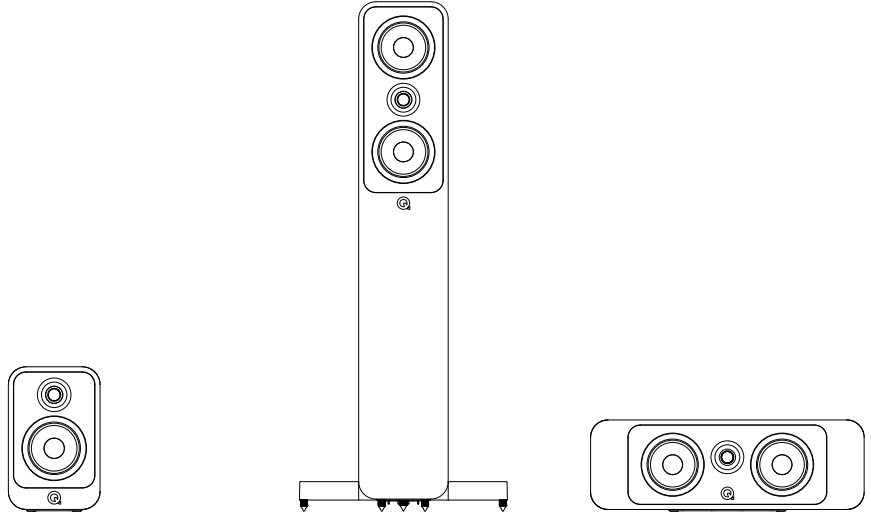

	Concept 30	Concept 50	Concept 90
<b>Bass unit</b>	1 x 125 mm (5.0 in)	2 x 125 mm (5.0 in)	2 x 125 mm (5.0 in)
<b>Treble unit</b>	1 x 25 mm (0.9 in)	1 x 25 mm (0.9 in)	1 x 25 mm (0.9 in)
<b>Frequency response (-6dB)</b>	54 Hz - 30 kHz	42 Hz - 30 kHz	67 Hz - 30 kHz
<b>Nominal impedance</b>	6 Ω	6 Ω	6 Ω
<b>Minimum impedance</b>	3.9 Ω	3.6 Ω	3.7 Ω
<b>Sensitivity (2.83V @ 1kHz)</b>	87 dB/w/m	90.5 dB/w/m	90 dB/w/m
<b>Recommended amplifier power</b>	25-100 W	25-150 W	25-150 W
<b>Crossover frequency</b>	2.4 kHz	2.1 kHz	2.1 kHz
<b>Distortion (120Hz - 20kHz, @2.83Vrms)</b>	<0.2%	<0.2%	<0.2%
<b>Effective volume</b>	7.0 L	28.8 L	11 L
<b>Dimensions HxWxD (per loudspeaker)</b>	284 x 180 x 319 mm (11.2 x 7.1 x 12.6 in)	Inc spikes and stabiliser: 1025 x 418 x 319 mm (40.4 x 16.5 x 12.6 in)  Cabinet width: 180 mm (7.1 in)	184 x 550 x 259 mm (7.2 x 21.7 x 10.2 in)
<b>Weight (per loudspeaker)</b>	7.9 kg (17.4 lbs)	22.9 kg (50.5 lbs)	12.3 kg (27.1 lbs)

Please contact your local Areas Sales Manager for further information.

E: [sales@armourhome.co.uk](mailto:sales@armourhome.co.uk)  
T: +44 (0)1279 50 11 11