

Music System Home

Generation 2

Owner's Manual

Tivoli Audio[™]

Contents

English 2

Deutsche.....24

Español47

Français.....70

Italiano 93

Nederlands.....116

Norsk.....138

Suomi160

Svenska182

日本語.....204

한국어.....230

中文.....255

EU Declaration of Conformity.....279

Welcome

Thank you for choosing Tivoli Audio!

Music System Home - Generation 2

Wi-Fi / DAB+* / AM / FM / Bluetooth® All-in-one System

Combining vintage design, high-performance audio and modern technology, the Music System Home Generation 2 supports a variety of streaming services with the help of AirPlay 2 and Google Chromecast. The audio performance and dynamic range creates room filling audio and is a perfect companion to your entertainment system with a variety of ways to connect to your television. The embodiment of smart home audio and design, the Music System Home will connect you with the music and audio content you love.

Please take a moment to read this owner's manual and the safety instructions. If you have any questions, please do not hesitate to contact your dealer or Tivoli Audio.

*DAB is only available in supported countries.

Please save the original packing should you ever need to ship your radio. When packaging is no longer needed, please recycle.

Packed with your Music System Home you should find:

- (1) External Power Supply and accompanying cord
- (1) FM/DAB Telescopic Antenna
- (1) AM Antenna
- (4) Removable feet

Please contact your dealer or Tivoli Audio if any of these items are missing.

Guide to Features

Front Panel

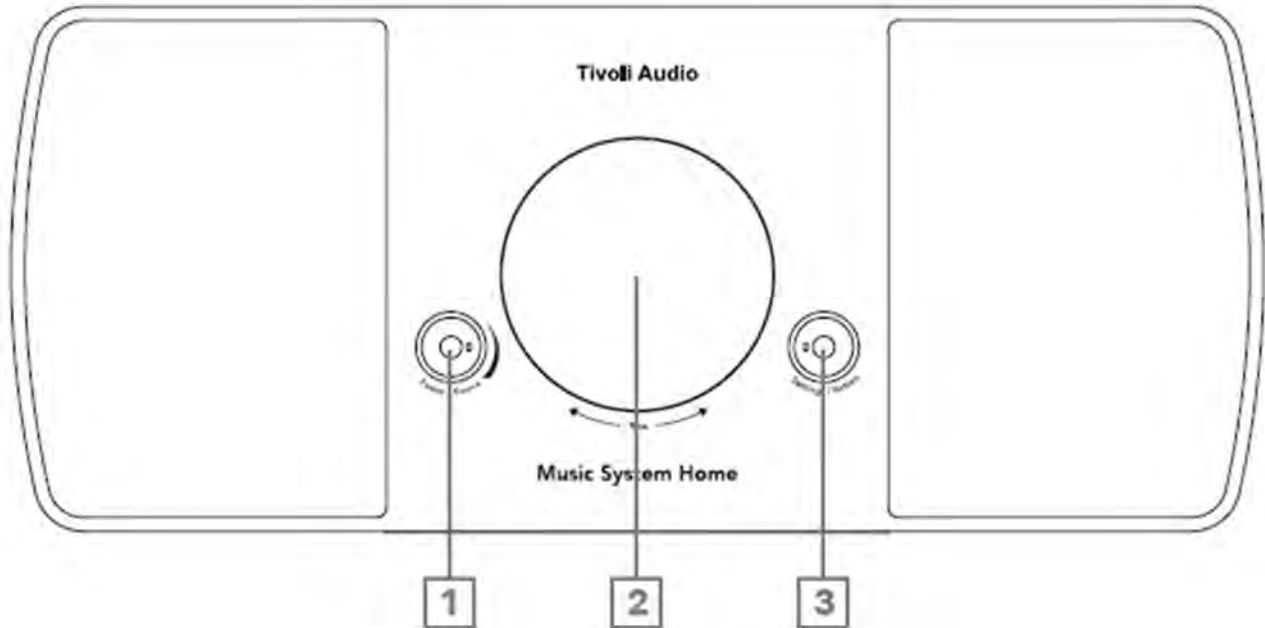

1. **POWER/SOURCE/VOLUME KNOB:** Push and hold to turn the unit on or off. Short press to cycle between WiFi, FM, DAB (if available), Bluetooth, and Auxiliary. Rotate right to increase volume, rotate left to decrease volume.
2. **BEZEL CONTROL**
In FM/AM/DAB mode: Turn left to tune down. Turn right to tune up. Short press to add a station to your presets. Double press to reload DAB station list or go to next FM/AM station.
In Bluetooth mode: Turn left to go to previous track. Turn right to go to next track. Short press to play/pause. Push and hold to enter Bluetooth pairing mode.
In WiFi Streaming mode: Turn left to go to previous track. Turn right to go to next track. Short press to play/pause.
3. **SETTINGS/ACTION KNOB:** The Settings menu allows you to use additional features such as the built in Sleep Timer, Alarm, and Brightness control. See the "Settings" section of this manual for more information.

Rear Panel

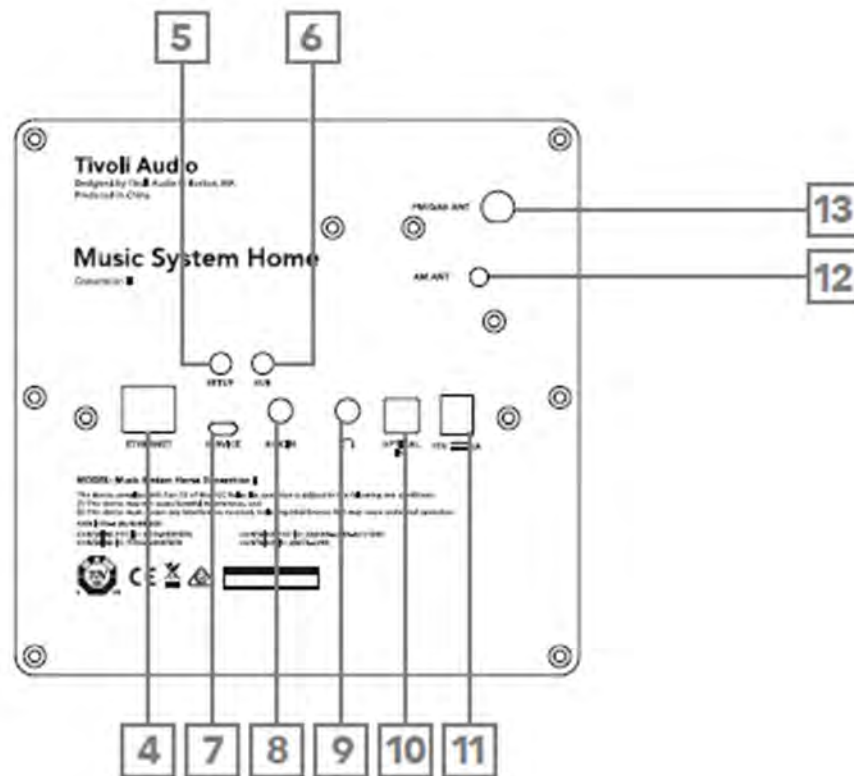

4. **ETHERNET:** Optional connection for your Music System Home to connect to your home network via ethernet cable instead of WiFi.
5. **SETUP:** Tap to enable your speaker to be connected to your home network.
6. **SUB:** Press to connect to a Bluetooth-enabled Model Sub. Consult the “Sub Out” section of the manual for more information.
7. **SERVICE:** Service port. Only for use by an Authorized Tivoli service center.
8. **AUX IN:** Plug in audio directly for a standalone experience.
9. **HEADPHONE OUT:** Connect a headset (not included) to this variable stereo output for private listening.
10. **OPTICAL IN:** Plug in audio directly for a standalone experience. Perfect for A/V receivers and TVs.
11. **DC Power:** Plug in the provided Tivoli Audio power adapter to power your Music System Home.
12. **AM Antenna:** Insert the included AM antenna into this 3.5mm jack.
13. **FM/DAB Antenna:** Connection for pre-installed FM/DAB antenna.

WiFi Mode

Setting up your Music System Home on WiFi with Google Home

1. Turn on your unit by short pressing the power knob.
2. On your radio, short press the power knob until the screen on the Music System Home says "WiFi". Wait for the screen on the unit to show "WiFi Setup Enabled"
3. Install the Google Home app by downloading the Google Home app on your Chromecast enabled smart phone/tablet.
4. Make sure to connect your smart phone/tablet to the same network that you intend to use to set up your Music System Home with Chromecast built-in™.
5. Open the Google Home app by tapping the app icon on your smart phone/tablet.
6. Tap Get Started or the "+" sign in the corner.
7. Tap "Set up device".

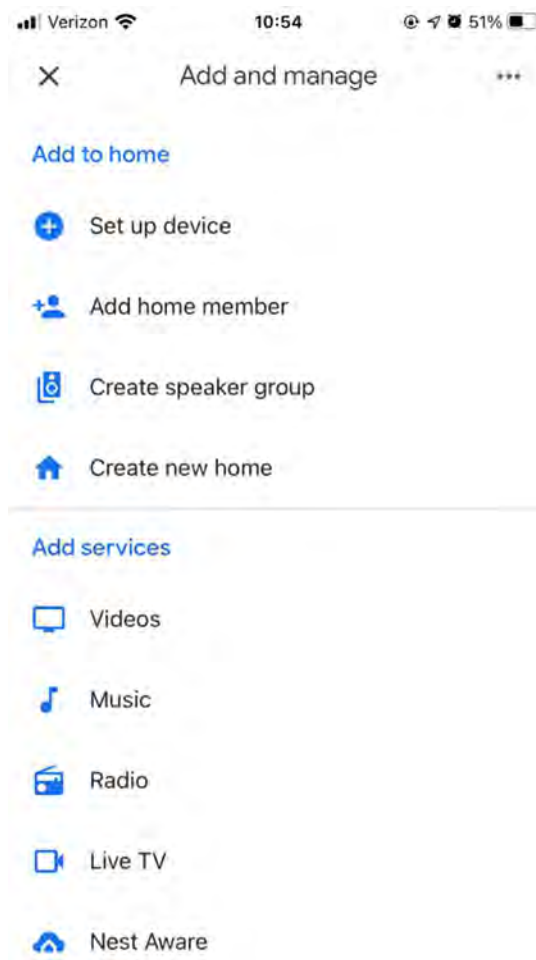

8. Tap "Set up new devices in your home".

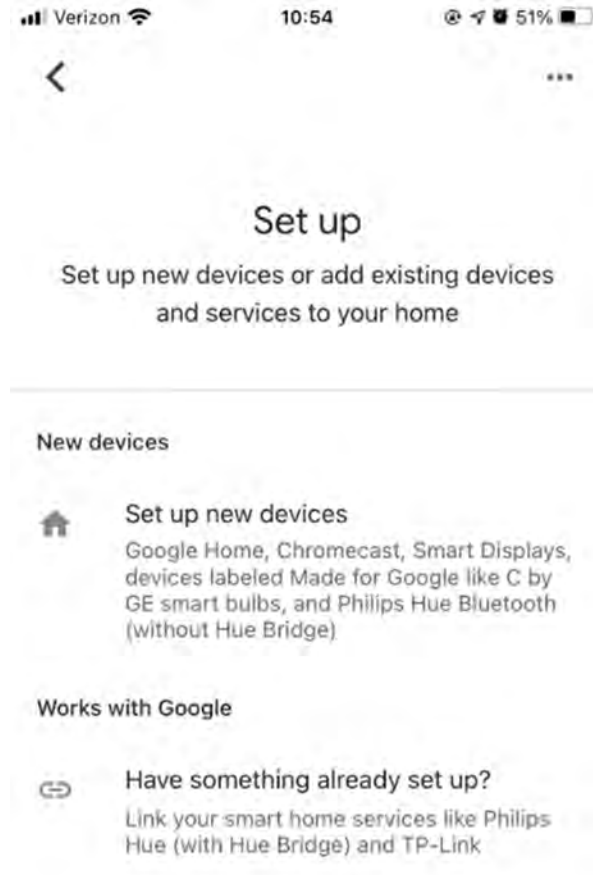

9. Tap "Home" or if you have other homes, the Home on the screen you wish to add your Music System Home to. Tap "Next".

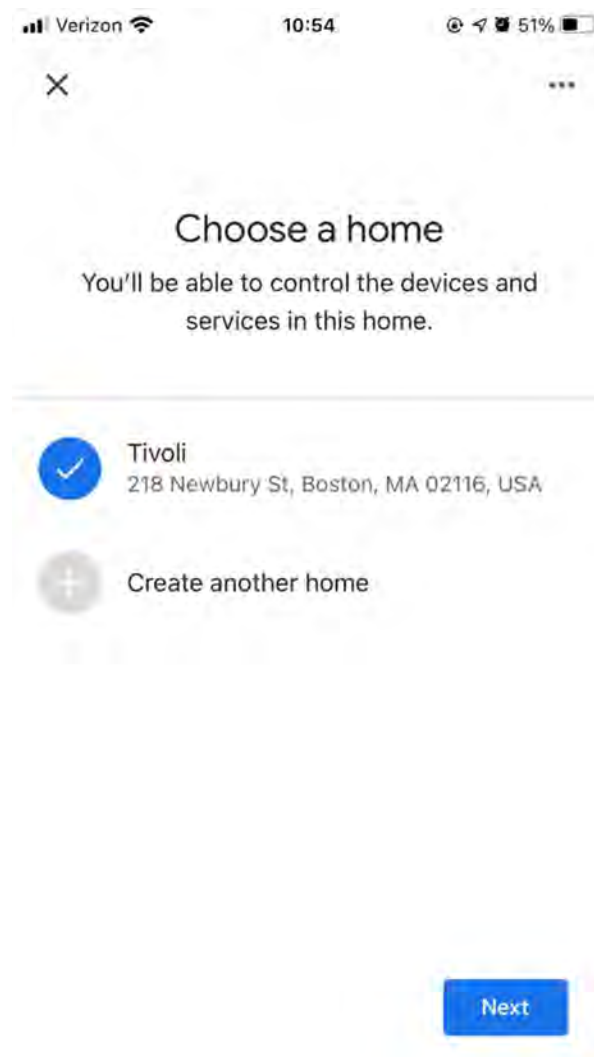

10. If you haven't already done so, turn on your phone's Bluetooth connection. This allows your WiFi information to be sent reliably to the speaker.

11. You should see "Tivoli Audio Music System Home" found on the screen. Tap "Yes".

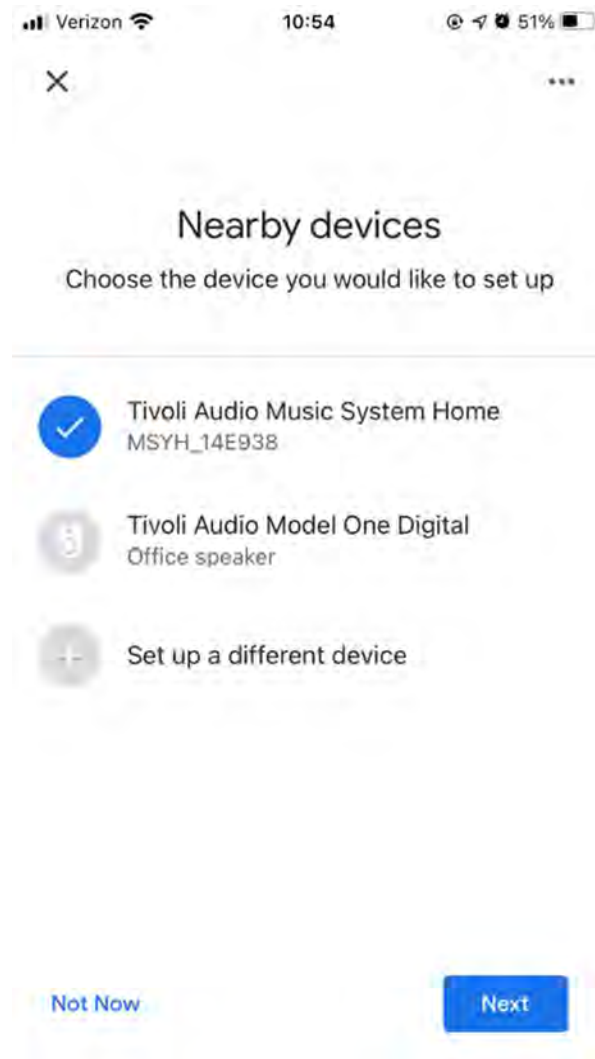

12. Select "Yes" when you hear the sound from the speaker.

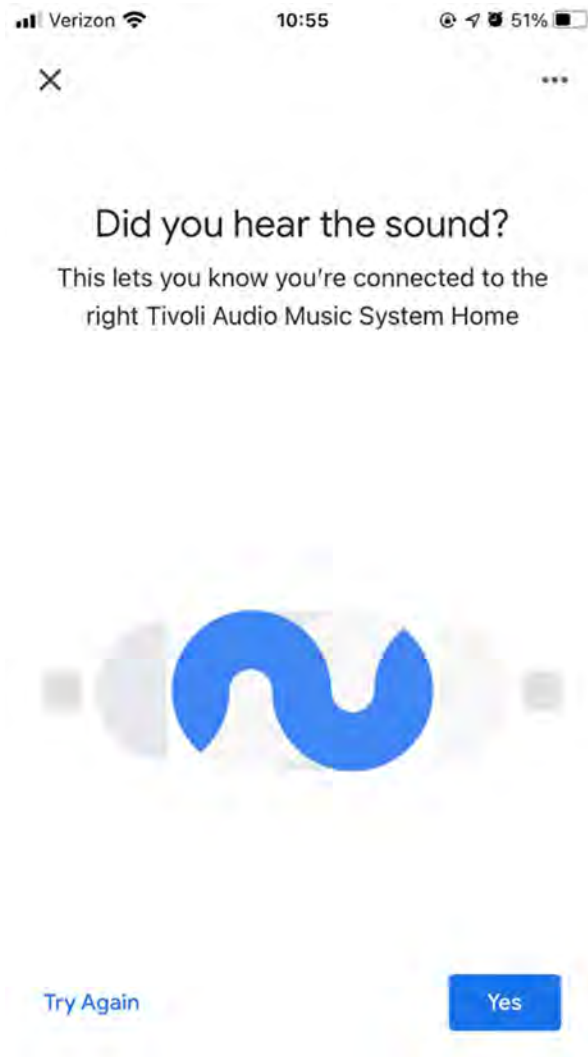

13. Decide whether or not you would like to opt into Google's crash reports. There is no wrong answer!

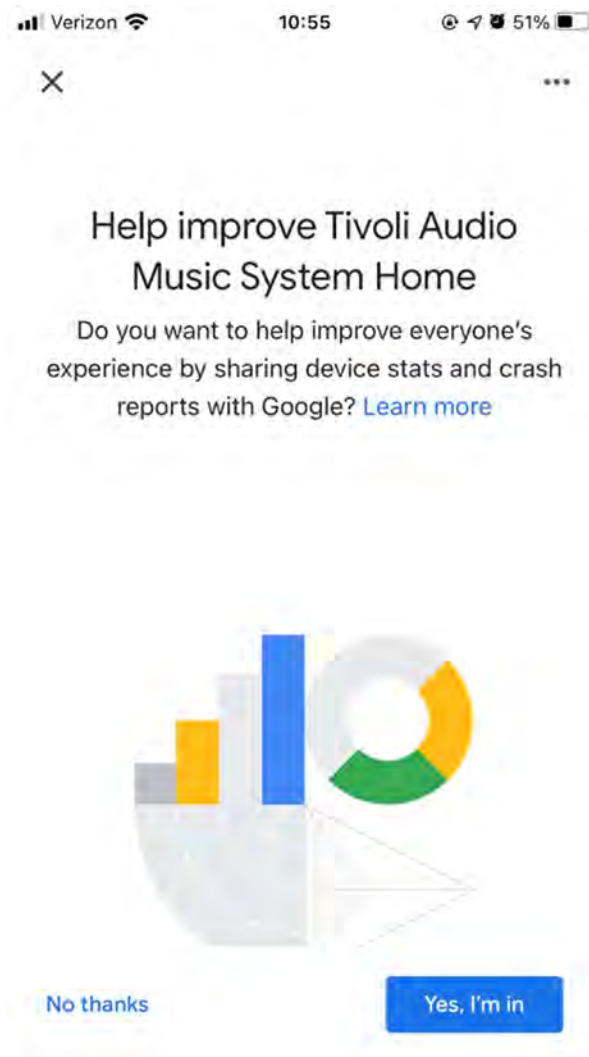

14. Choose a location for your device, for example "Living Room". Select "Next".

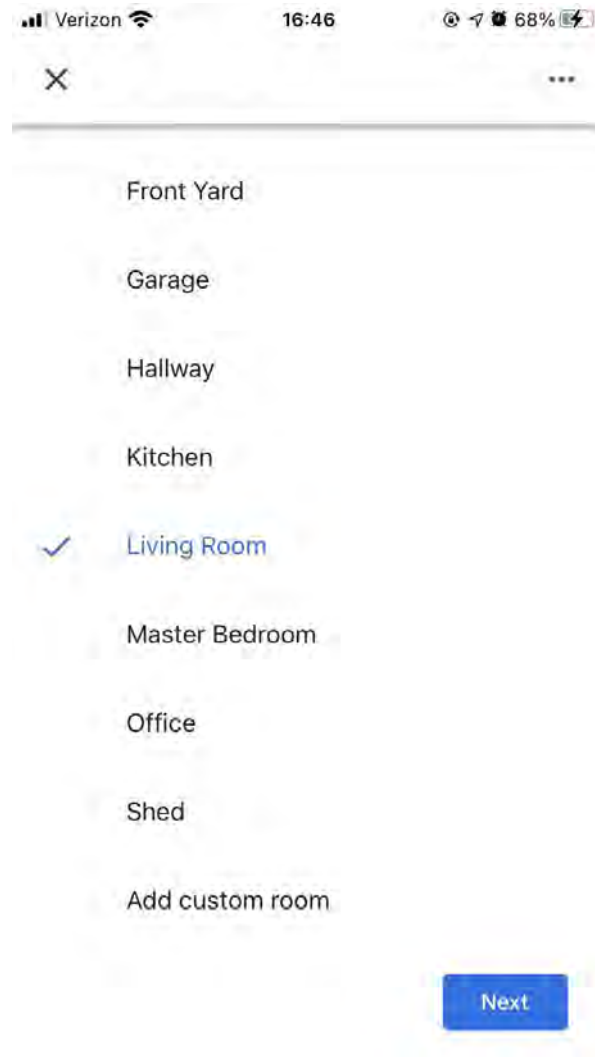

15. Name your device whatever you would like to name it, and select "Next".

16. Select the WiFi network you would like your speaker to be on, and select "Next".

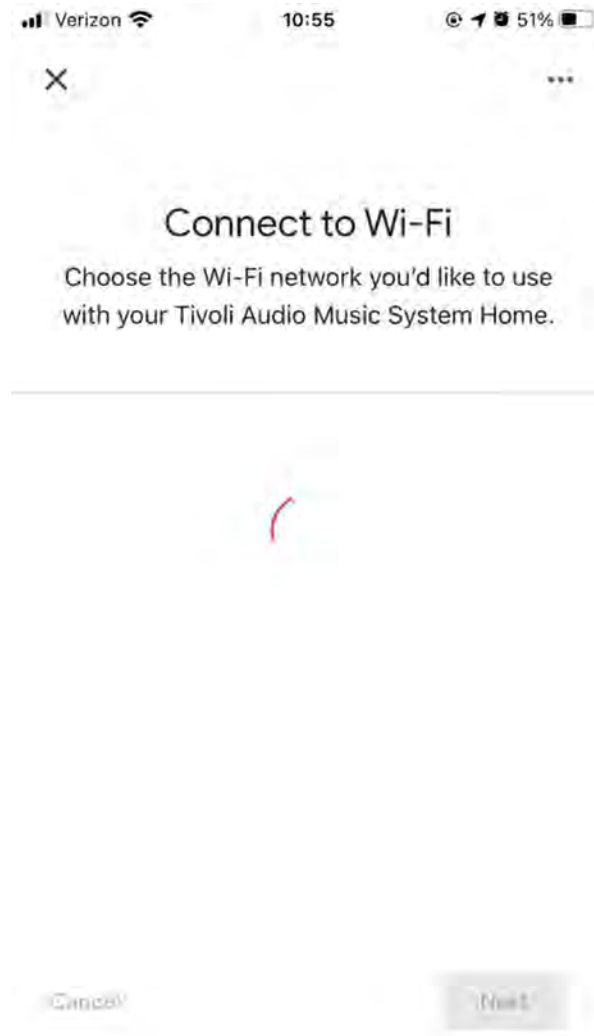

17. Wait while your Music System Home connects to your WiFi network, until you briefly see "Connected" on your device's screen as well as "Connected" on the Music System Home's screen.

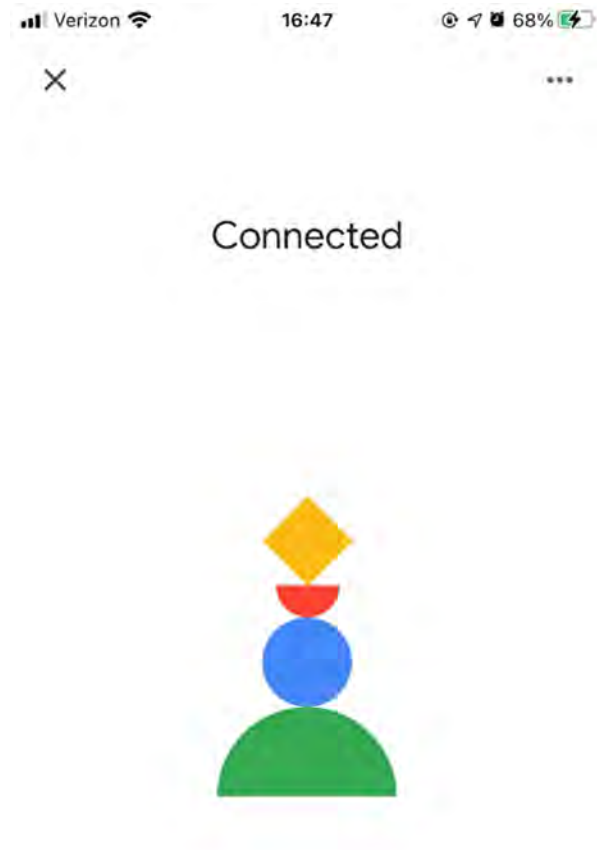

18. If you would like to link your Google account to your Music System Home, you can choose to do so on this screen.
19. After reading the disclaimers about Google Assistant, select "Next".
20. If you wish to link any music services, can do so at this screen. If not, select "Not now".
21. Your Music System Home is ready to play music! Hit "Next", and then "Continue".

Once connected, stream the entertainment you love from your phone, tablet or laptop to your speaker.

Setting up your Music System Home on WiFi with Apple AirPlay2

Requires an iPhone, iPad, or iPod touch with iOS 11.4 or later or Mac with iTunes 12.8 or later

1. Turn on your unit by short pressing the power knob.
2. On your radio, short press the power knob until the screen on the Music System Home says "WiFi". Wait for the screen on the unit to show "WiFi Setup Enabled".
3. On your iOS device, go to WiFi Settings. Make sure to connect your iOS device to the network that you intend to use your Music System Home.
4. Scroll down to "Set Up New AirPlay Speaker...", and select "MSYH_XXXXXX".

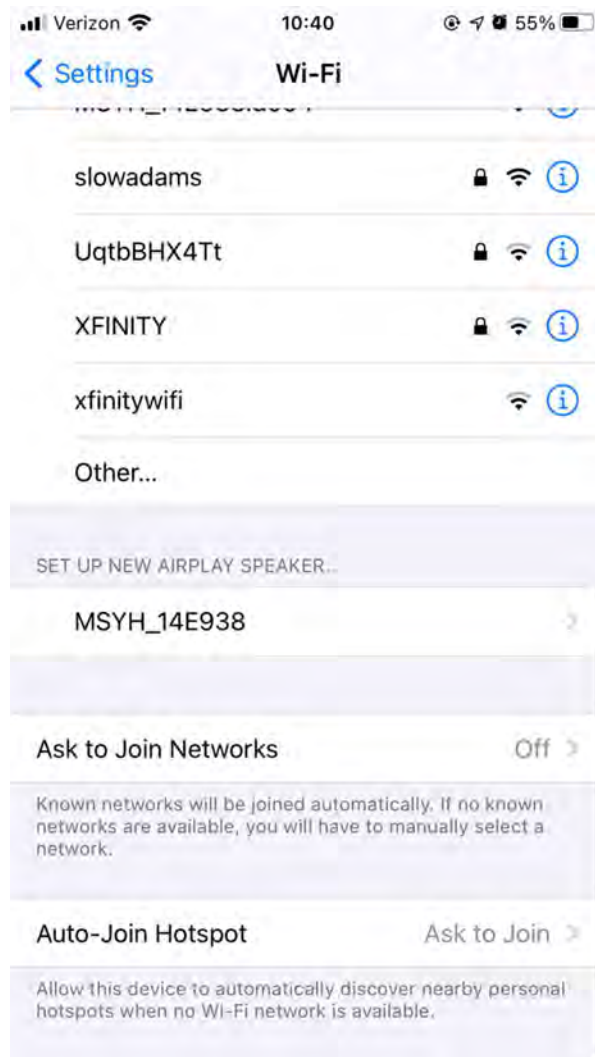

5. Rename your speaker (recommended), and create a password (optional).
6. Select "Next" and wait for the connection.

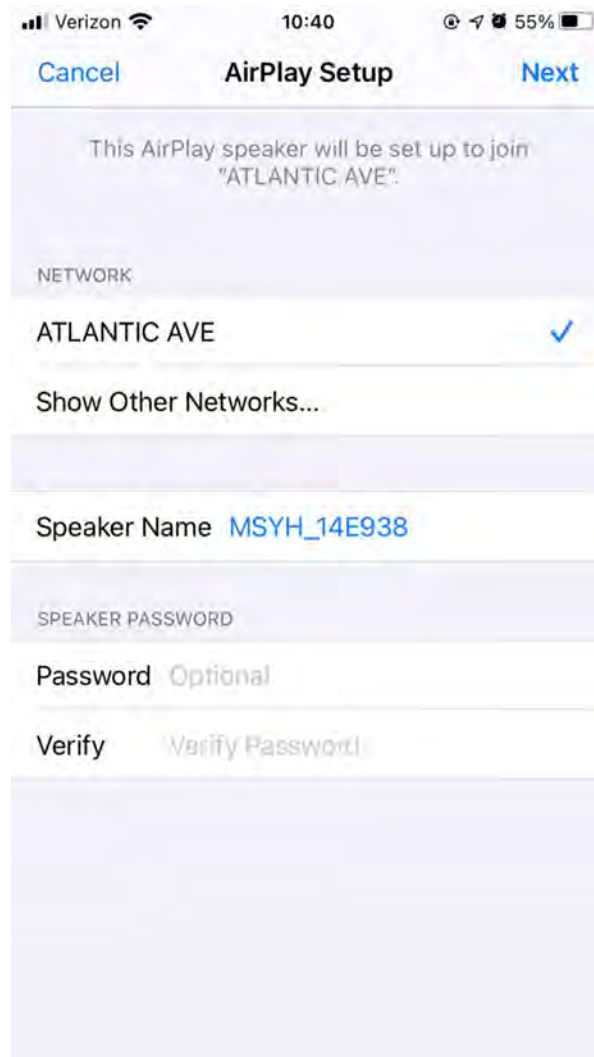

7. Wait for the connection confirmation, select "Done".

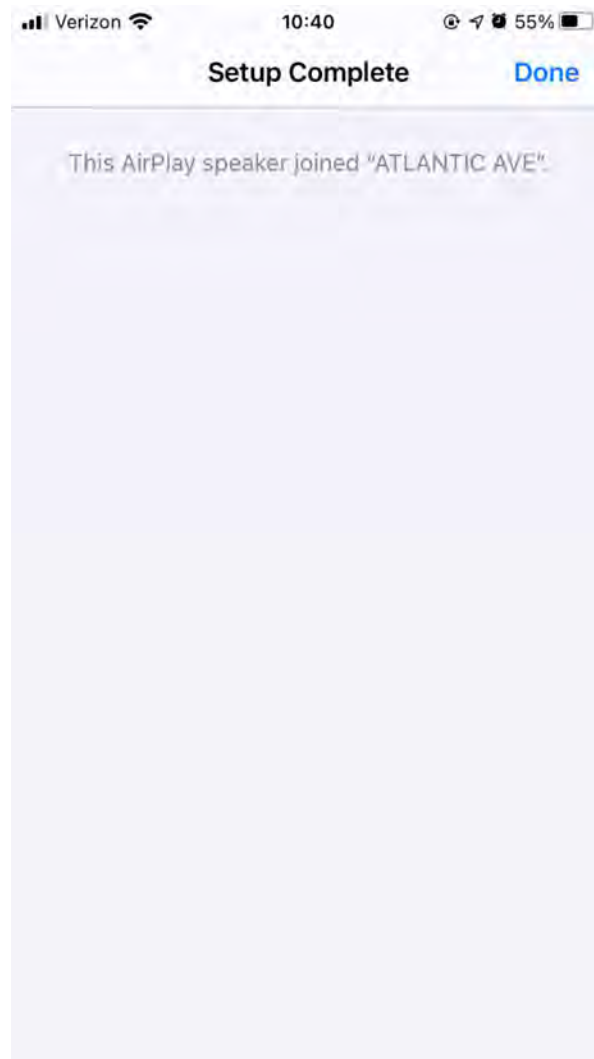



8. Your speaker is now ready to use with AirPlay 2. With AirPlay 2, you're in control of your audio.

How to use Chromecast built-in™:

1. Open any Chromecast-enabled app.
2. Select the CAST button in the app. 
3. Select the Music System Home.
4. Press the PLAY button in the app.

For additional support, please visit support.google.com/chromecast

How to use AirPlay 2:

1. Connect your iOS device to the same network as your Music System Home.
2. On your iOS device, open the Control Center.
3. Press and hold the audio card in the upper-right corner, then tap the AirPlay logo.  
4. Select your Music System Home from the list of available AirPlay devices, and start playing.

For additional support, please visit support.apple.com

How to use Spotify Connect:

1. Use your phone, tablet or computer as a remote control for Spotify. Go to spotify.com/connect to learn how.

Add a Spotify playlist to your presets: Use your remote to add a playlist to your saved presets. Simply press and hold the number preset you would like to use and wait for the on-screen confirmation. To delete the preset, hold down the number preset button on the remote control.

*The Music System Home will need to be set up on WiFi using Airplay 2 or Google Home in order for Spotify connect to operate. Spotify connect may require a premium subscription account.

Bezel Control

While streaming any music source over WiFi, the Bezel wheel does the following

Play/Pause: To play or pause music, short press the Bezel.

Next Track: To go to the next track in an album or playlist, rotate the bezel right.

Previous Track: To go to the previous track in an album or playlist, rotate the bezel left.

Settings Knob

Please go to the settings section for detailed operation.

Bluetooth Mode

Pairing

Your Music System Home can act as a standalone Bluetooth speaker.

1. On your radio, short press the POWER/SOURCE/VOLUME KNOB until the screen on the Music System Home says "Bluetooth" in the upper left-hand corner.
2. On your radio, press and hold the BEZEL until the screen on the Music System Home says "Pairing Enabled" in the center.
3. Go to the Bluetooth settings screen on your phone or tablet.
4. Select the device that has a name similar to "MSYH_XXXXX".
5. Once the radio displays "Pairing Success" on its screen, you are paired to the radio.
6. You can begin playing your music via Bluetooth.

Bezel Control

While streaming any music source over Bluetooth, the Bezel wheel does the following:

Play/Pause: To play or pause music, short press the Bezel.

Next Track: To go to the next track in an album or playlist, rotate the bezel right.

Previous Track: To go to the previous track in an album or playlist, rotate the bezel left.

Enable Pairing: To enable pairing, press and hold the Bezel until screen displays "Pairing Enabled".

Settings Knob

Please go to the settings section for detailed operation.

Auxiliary Mode

Your Music System Home can be used as a standalone speaker. Simply use an 1/8" stereo cable to attach any line or headphone level source into the AUX input on the back of your radio. You can control the volume of the speaker using the volume control on the Music System Home or with the volume control of your audio source.

FM/AM Mode

Bezel Control

Manual Tune Up: To manually tune up to a higher frequency station, rotate the bezel to the right.

Manual Tune Down: To manually tune down to a lower frequency station, rotate the bezel to the left.

Autoscan Up: To autoscan to a higher frequency, quickly double press the bezel.

Add a station to your preset stations: To add a station to your saved preset stations, press the bezel once. It is also possible to add presets by using your remote. Simply hold the number preset you would like to use, and wait for on-screen confirmation. To delete the preset, either hold down the button on the remote or long press on the bezel control.

Settings Knob

Please go to the settings section for detailed operation.

DAB/DAB+/DMB Mode

Bezel Control

Manual Tune Up: To manually tune up to a higher frequency station, rotate the bezel to the right.

Manual Tune Down: To manually tune down to a lower frequency station, rotate the bezel to the left.

Rescan: To rescan for all DAB stations, quickly double press the bezel.

Add a station to your preset stations: To add a station to your saved preset stations, press the bezel once. Once added, you may access it using the remote. It is also possible to add presets by using your remote. Simply hold the number preset you would like to use and wait for on-screen confirmation. To delete the preset, either hold down the button on the remote or long press on the bezel control.

Settings Knob

Please go to the settings section for detailed operation.

SUB OUT

To connect your Music System Home to a Model SUB for a 2.1 audio experience. Pressing the SUB button automatically enables a bass cut function, which may be disabled separately through the Settings Menu.

1. Connect the receiver to power using the supplied USB cable to a 5V power supply (not included).
2. Check the switch on the receiver is set to "Rx".
3. Plug one end of the included 3.5mm Adapter into the receiver, the other end into the Line Input of your Model SUB.
1. NOTE: The Model SUB must be set to Auxiliary Input mode.
4. Short press the "SUB" button on the back of your Music System Home.
5. Short press the button on the receiver. The light will start blinking rapidly, indicating pairing mode.
6. Once connected, the light on the receiver will flash in an intermittent pulse.

The volume of your Model SUB must be set independently from the Music System Home. If either the Receiver or Music System Home is turned off, the pairing process must be repeated.

Please note: The BT Sub Receiver is packaged with the Model SUB.

Settings

Note: All of these functions are available through the remote using the  option on the remote as well.

Clock Set

Manual Time Set: Push the Settings/Action knob, then turn it until "Manual Time Set" appears onscreen.

Push the Settings/Select knob. Select the hour by turning the Settings/Select knob and press it to confirm. Do this again to select the minute, meridian, day, month, and year. To confirm, select YES then press the Settings/Select knob.

Auto Time Enable: To allow your Music System Home to update the time via WiFi, FM, or DAB, set to "Enable". Selecting "Disable" will require you to manually set the time.

Alarm Set

Push the Settings/Select knob, then turn it until "Alarm Set" appears onscreen. Push the Settings/Select knob. Select the hour by turning the Settings/Select knob and press it to confirm. Do this again to select the minute, and whether you would like the alarm to be active. To confirm, select YES then press the Settings/Select knob.

Sleep Time Set

Push the Settings/Select knob, then turn it until "Sleep Time Set" appears onscreen. Push the Settings/Select knob. Select the hour by turning the Settings/Select knob and press it to confirm. Do this again to select the minute. To confirm, select YES then press the Settings/Select knob.

Network Set (for Ethernet users)

This is used to connect your Music System Home to an ethernet connection. Push the Settings/Select knob, then turn it until Network Set appears onscreen. Push the Settings/Select knob. Turn the Settings/Select knob to "Ethernet" if using the wired Ethernet port in the back of the Music System Home. If you are using WiFi, ensure that this is set to WiFi. Both cannot be used at the same time.

FM Scan Strength

In FM Mode, push the Settings/Select knob, then turn it until "FM Scan Strength" appears onscreen. Push the Settings/Select knob. Select the desired scan strength by turning the Settings/Select knob, then push the Settings/Select knob to confirm.

FM Tuning Step

In FM Mode, push the Settings/Select knob, then turn it until "FM Tuning Step" appears onscreen. Push the Settings/Select knob. Select the desired tuning step for your region by turning the Settings/Select knob, then push the Settings/Select knob to confirm.

RDS Data

In FM Mode, push the Settings/Select knob, then turn it until "RDS Data" appears onscreen. Push the Settings/Select knob. Select a setting by turning the Settings/Select knob, then push the Settings/Select knob to confirm.

AM Scan Strength

In AM Mode, push the Settings/Select knob, then turn it until "AM Scan Strength" appears onscreen. Push the Settings/Select knob. Select the desired scan strength by turning the Settings/Select knob, then push the Settings/Select knob to confirm.

AM Tuning Step

In AM Mode, push the Settings/Select knob, then turn it until "AM Tuning Step" appears onscreen. Push the Settings/Select knob. Select the desired tuning step for your region by turning the Settings/Select knob, then push the Settings/Select knob to confirm.

Firmware Version

Push the Settings/Select knob, then turn it until "FW Version" appears onscreen. Push the Settings/Select knob to view the current firmware version.

Display Contrast Settings

Push the Settings/Select knob, then turn it until "Contrast" appears onscreen. Push the Settings/Select knob. Turn the Settings/Select knob until the desired Contrast is achieved, then press the Settings/Select knob.

Factory Reset

A Factory Reset will restore all features on Music System Home to their default settings. Push the Settings/Select knob, then turn it until "Factory Reset" appears onscreen. Push the Settings/Select knob. Turn the Settings/Select knob until the confirmation appears, then press the Settings/Select knob.

Auto Power Off

This allows your Music System Home to shut itself off if it is idle for a period of time. Push the Settings/Select knob, then turn it until "Auto Power Off" appears onscreen. Push the Settings/Select knob. Turn the Settings/Select knob until the confirmation appears, then press the Settings/Select knob. "Enable" will set the model to turn off after it is idle for a period of time. "Disable" will turn this feature off and your unit will always stay on until you manually power it off.

Bass Cut

This allows you to lower the level of bass frequencies emitted from your Music System Home. Push the Settings/Select knob, then turn it until "Bass Cut" appears onscreen. Push the Settings/Select

knob. Turn the Settings/Select knob until YES appears in order to lower the bass, NO if you want the bass to remain as the original EQ was intended. This option is automatically enabled when using SUB OUT.

WiFi Info

Select this to view WiFi information about your unit, such as WiFi version and its IP address.

Bluetooth Info

Select this to view the Bluetooth firmware information of your unit

Other Information

Firmware Updates

Your Music System Home will have periodic software updates about every 4 months (and also possibly when you first use the product). The speaker will automatically update itself when it is connected to WiFi. No need to do anything!

Care

A dry cloth is recommended to clean the back and wooden cabinet of your Music System Home. A lint roller can be used to clean the fabric on the front. Do not expose to water.

Limited Warranty

Tivoli Audio manufactures its products to very high standards and we are confident our products will perform well. Accordingly, we warranty our products against manufacturing defects in material and workmanship to the original owner, for a period of one year in the United States and two years in the European Union from the original date of purchase. For countries where minimum warranty terms are determined by statute, the warranty term is the statutory period required. In all other locations, the warranty term is one year.

This warranty does not extend to damage caused by improper installation, faulty ancillary equipment, modifications, unauthorized repair, shipping damage or loss, abuse, accidents, use on improper voltage/current, lightning or other acts of God, normal wear and tear, commercial use, or purchase from unauthorized dealers. Proof of purchase as evidence the unit was purchased from an authorized dealer within the warranty period may be required for warranty service. Should service be necessary, please do NOT return the product without first contacting your dealer or Tivoli Audio.

This warranty is non-transferable. Tivoli Audio will not pay for loss of time, inconvenience, loss of use of the product, or damages caused by this product.

This warranty gives you specific legal rights and you may also have other rights which vary from state to state. Some states do not allow limitations on implied warranties or the exclusion of consequential damages, therefore, these restrictions may not apply to you.

For more warranty information please visit us at www.tivoliaudio.com

For European warranty information please visit www.tivoliaudio.eu

Licenses

Google, Google Home and Chromecast built-in are trademarks of Google LLC.

Use of the Works with Apple badge means that an accessory has been designed to work specifically with the technology identified in the badge and has been certified by the developer to meet Apple performance standards.

The Spotify Software is subject to third party licenses found here:

<https://www.spotify.com/connect/third-party-licenses>.

The Bluetooth® word mark and logos are registered trademarks owned by Bluetooth SIG, Inc. and any use of such marks by Tivoli Audio, Inc is under license. Other trademarks and trade names are those of their respective owners.

The Wi-Fi CERTIFIED™ Logo is a registered trademark of Wi-Fi Alliance®.