

# KAM

## USER MANUAL

KML203  
Kam iLink-60G

KML205  
Kam iLink-750B

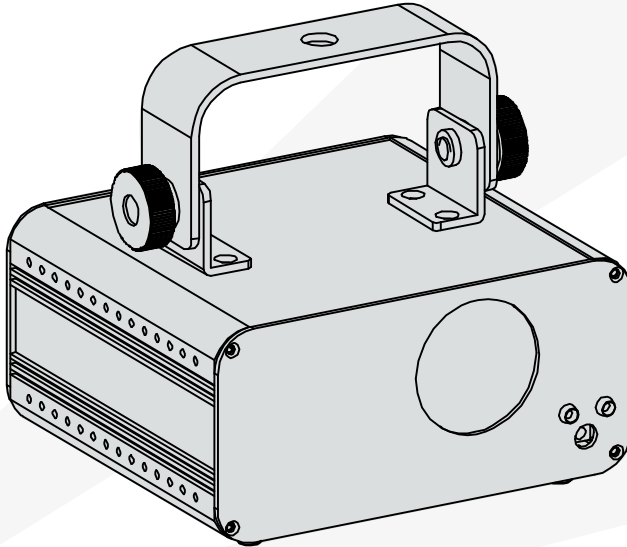

Worldwide Trade Distributors  
[www.jhs.co.uk](http://www.jhs.co.uk)

[www.kam.co.uk](http://www.kam.co.uk)

JHS, SALEM HOUSE, PARKINSON APPROACH, GARFORTH, LEEDS LS25 2HR, UK.  
©2020 JHS. Specifications are subject to change without prior notice. Made in China.

Version 7.0



# Unpacking Instructions

---

## Read Manual before Operation

Dear user,  
Thanks for choosing our laser device. Before operating this device, please read this manual thoroughly, and retain it for future reference.

## Warning Data

Please note the warnings in bold which will ensure the safe and smooth operation. These warnings are important to a certain extent.



**Attention!** Indicates a skill or other useful information for special situations.



**Important!** Indicates important information to protect personnel from laser incident or injury.



**Caution!** Prevent damage or injury from incorrect operation.



**Laser!** Laser safety warning labels.

### Warning!

If the external flexible cable or cord of this luminaire is damaged, it shall be replaced by a special cord or cord exclusively available from the manufacturer or his service agent.

Shields, lenses or ultraviolet screens shall be changed if they have become visibly damaged to such an extent that their effectiveness is impaired, for example by cracks or deep scratches.

The lamps shall be changed if it has become damaged or thermally deformed.

## Unpacking Instructions

Carefully unpack the carton, checking contents to ensure that all parts are in good condition.

Informing the shipper immediately and retaining packing material for inspection if any parts damaged from shipping or device damaged. Keep packing materials as evidence for shipper's confirmation.



### Attention!

This unit is in perfect condition before delivery; please check all accessories when unpacking the unit. User should follow this user manual to operate this unit, and make sure that you are clear on all laser safety information and unit operation before power it on. Any wrong operation will make this unit out of warranty.

| NAME                  | QTY   |
|-----------------------|-------|
| Laser Light           | 1 PCS |
| KEYs (for key switch) | 2 PCS |
| Power Cord            | 1 PCS |
| Interlock Connector   | 1 PCS |

# Safety Instructions

## Safety Instructions



To protect the environment, please try to recycle the packing material as much as possible.



The projector is for indoor use only, IP20. Use only in dry locations. Keep this device away from rain and moisture, excessive heat, humidity and dust. Do not allow contact with water or any other fluids, or metallic objects



Don't throw this product away just as general trash, please follow the abandon electronic product regulation in your country.



Locate the fixture in a well ventilated spot, away from any flammable materials and/or liquids. The fixture must be fixed at least 50cm from surrounding walls

- ◆ To avoid condensation to be formed inside, allow this unit to adapt to the surrounding temperatures when bringing it into a warm room after transport.
- ◆ **Condensation** sometimes prevents the unit from working at full performance or may even cause damages.
- ◆ Don't install it on flammable object.
- ◆ Do not use it when maximum ambient temperature is higher than 40 degree.
- ◆ Unplug the unit when it is not used for a longer time or before replacing the bulb.
- ◆ Don't open the top cover to avoid unit damage.
- ◆ Please use the original packing when the device is to be transported.

## Laser Safety Warnings



According to EN 60825-1:2007, this product belongs to class 3B. Direct eye contact may cause injury.



- ◆ This product is for laser show only. The class 3B laser light should be operated by professional operator only.

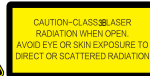

- ◆ This is so-called show laser, emitting radiation with a wavelength spectrum between 400 and 700nm and producing lighting effects for shows.
- ◆ International laser safety regulations require that the vertical height from installment to ground is more than 3 meters, horizontal distance is 2.5 meters from audience.
- ◆ Never direct the laser beam to people or animals and never leave this device running unattended.
- ◆ The legal requirements for using laser entertainment products vary from country to country. The user is responsible for the legal requirements at the location/country of use.



Warning! Avoid direct eye contact with laser beams during operation, especially when the laser beams stay still, or injury to eyes may occur.



### Laser Safety Protection Feature



Caution! The laser security measures are designed according to the specific terms of the relevant international laser safety standards and has the following laser safety protection means.

Laser key switch: laser is available only when the key is turned on.

Laser Emergency switch: remote connecting switch, it will cut off the laser light path emergently once the device in potential hazard;

Laser indication : laser indication on the front panel of the laser light for indicating " laser-ready ".

Laser safety label: The labels of according with European standard are stucked on the device body.

# Overhead Rigging

 Attention! The installation must be carried out by qualified service personal only. Improper installation can result in serious injuries and /or damage to property. Overhead rigging required extensive experience! Working load limits should be respected, Certified installation materials should be used, the installed device should be inspected regularly for safety.

- ◆ Make sure the area below the installation place is free from unwanted persons during rigging, de-rigging and servicing.
  - ◆ Locate the fixture in a well ventilated spot, far away from any flammable materials and/or liquids. The fixture must be fixed at least 50cm from surrounding walls
  - ◆ The device should be installed out of reach of people and outside areas where persons may walk by or be seated.
  - ◆ The device should be well fixed; a free swinging mounting is dangerous and may not be considered!
  - ◆ Do not cover any ventilation opening as this may result in overheating
- Before the first time use, it must be inspected by professional staff to make sure safety, inspection regularly every year.

 Before rigging make sure that installation area can hold the 10 times weight of device. Using the steel rope which can hold 12 times weight of device, through the eye-bolt for assisting hang

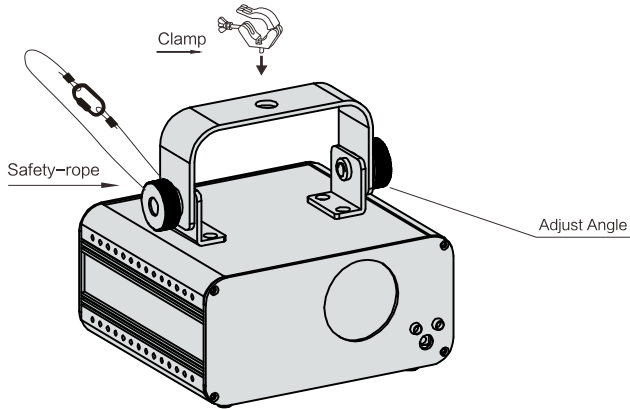

## AC Power

Please use the attached power, note that power voltage and frequency are the same as the marked voltage and frequency of device when connecting power. Every device' s power should be connected separately, so that device can be controlled individually.

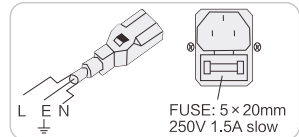

The power cord specification table:

| Cable(EU)    | Cable(US) | Pin     | International   |
|--------------|-----------|---------|---|
| Brown        | Black     | Live    | L   |
| Light blue   | White     | Neutral | N   |
| Yellow/Green | Green     | Earth   |  |

# Overhead Rigging

## DMX connection

- ◆ Connection between laser lights and DMX must use the shielded cable of diameter more than 0.5mm. Please use the attached 3 pin XLR plug/socket to connect the DMX output/input interface. The connection between socket and cable as below( note the plug/socket's 3 pin number and position).

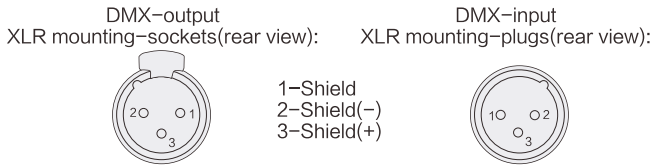

- ◆ Note, XLR plug/socket's 3pin can not be touched by inner hull, connection between pins is not allowed. Except above connection, XLR plug/socket can not be connected with XLR control line. Device receives international standard DMX512(1990) control signal.
- ◆ When using standard DMX512 control signal, the last device's output interface must be connected to a DMX plug. This plug is putting a 120 ohm resistance between "canon" plug's 2 pin and 3 pin. Showing as below pic. Sticking this plug into the last device's signal output interface, it will avoid the interference during the process of signal transmission.

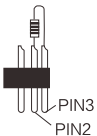

## Centring adjustment

In transportation, DMX mistake etc, laser image may deviate from the center of lens. You can use the LED digital panel to adjust motor and ensure laser program in the center of lens. Easy operation and practical function.

Pressing the 4 buttons at the same time, turning on the device, entering the model of digital centring. FUNC button choose SHE to set X axis and SHY to Y axis, the "UP" and "DOWN" to set deviation size. Observing the place of image and light lens, moving it to the right centre of light lens, then pressing the "ENTER" to confirm and save.

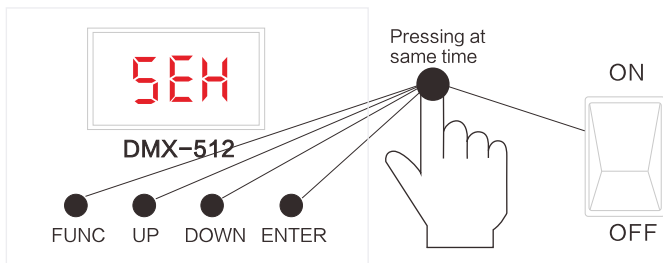

# Operation instructions

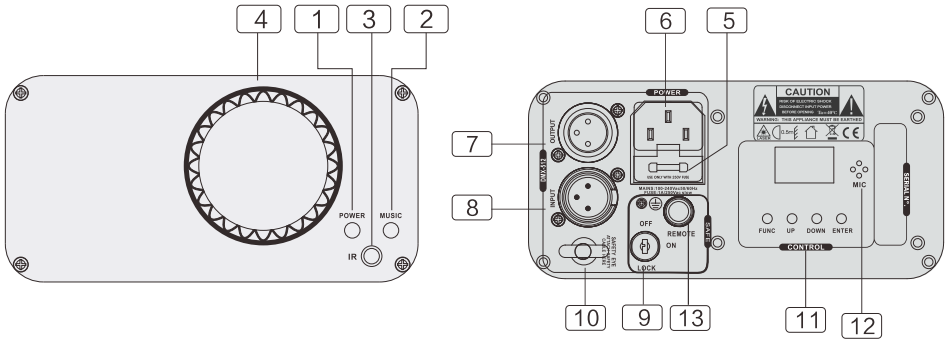

## Product operation diagram

| No | Name                  | Function   |
|----|-----------------------|--|
| 1  | POWER                 | Main power indicate LED. Red is ON.                                  |
| 2  | MUSIC                 | Synchronize to detected music signal                                 |
| 3  | IR                    | Infrared Remote Receiver   |
| 4  | Laser output          | Laser output aperture.   |
| 5  | Fuse Holder           | A backup fuse inside   |
| 6  | Mains input           | With socket and integrated fuse holder                               |
| 7  | DMX output            | 3PIN Female XLR port, using for DMX                                  |
| 8  | DMX input             | 3PIN Male XLR port, using for DMX                                    |
| 9  | Key switch            | Make sure the professional person use                                |
| 10 | Safety eye            | Connecting wire rope to prevent illegal operation and fall           |
| 11 | LED control interface | Various mode setting operation for machine                           |
| 12 | Mic                   | Microphone. Turn the knob to adjust the sound activated sensitivity. |

# Menu operating instruction

After every power on, the VERSION and MANUFACTURE INFORMATION will be shown in LCD monitor of rear panel. When laser is powered on, LCD monitor on rear panel shows the current operating standalone mode or DMX address of DMX mode. With help of LCD control panel, is very easy to set and change the operating mode of laser. After every resetting and saved, the new mode information will be shown on LCD monitor at next power on.

- FUNC** Mode Option, to choose the operating mode of laser.
- ENTER** Confirmation, to confirm the laser to show the present mode at the next operation.
- UP** **DOWN** UP/DOWN, to change operating mode, parameter or DMX address.

FIT-S(150R RE), FIT-S(50G RE), FIT-S(480B RE)  
 FITI-D(RG RE),FITI-D(GG RE),FITI-D(BB RE)

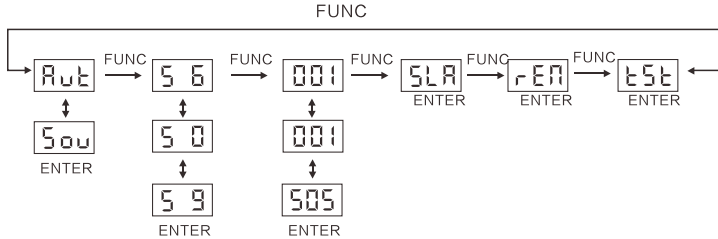

| LED Display | Function   |
|-------------|------------|
| AUT         | AUTO Show  |
| SOU         | SOUND Show |

FIT-S(RGY RE), FIT-S(RBP RE), FIT-S(GBC RE)

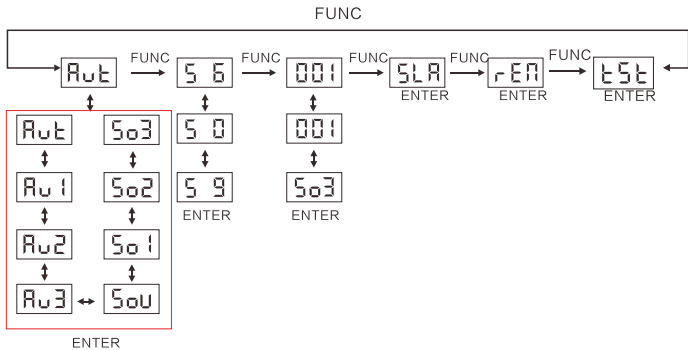

# Menu operating instruction

| LED Display | Function |
|-------------|----------|
| Aut         | Auto     |
| Au1         | Aut 1    |
| Au2         | Aut 2    |
| Au3         | Aut 3    |
| Sou         | Sound    |
| So1         | Sou 1    |
| So2         | Sou 2    |
| So3         | Sou 3    |

 Attention : In preprogrammed standalone SOUND mode, the laser beam will be blank-out in 3 seconds without AUDIO/MIC activated signal.

## Initial setting

| FUNC              | UP DOWN   | ENTER   |
|-------------------|---|---|
| Built-in Programs | AUT 5 shows Auto<br>A3D 3D shows Auto<br>AUB light beam show Auto<br>AUL Lumia show Auto<br>AUN AUTO show double bursting grating<br>AUX Universe nebula show Auto<br>SXX Above show with sound control                 | Press UP/DOWN to choose different effects, then press ENTER to confirm;   |
| Sound Sensitivity | LED displayer will play S0-S9, S0 means receive no any sound; from S1 to S9, the sensitivity is stronger and stronger;  | Press UP/DOWN to choose the sensitivity and press ENTER to confirm;   |
| DMX Mode          | DMX ADD 001 To DMX ADD 503  |   |
| Slave Mode        | Confirm the laser in SLAVE MODE. Connect MASTER laser with several SLAVE laser with DMX cable. SLAVE lasers are doing exactly the same laser show as MASTER laser.<br>Note: The slaves can't receive the remote signal; | If the words strobing always on the LED displayer, that means the DMX signal or the slave signal is not connected well, pls check the cables and the controller device. |
| REM Mode          | In any standalone mode excepted SLA, pressing ON/OFF for 2 seconds to activate remote function, and will be return the original mode pressing ON/OFF for 2S again;  | Choose UP/DOWN; press ENTER to confirm;   |



# Remote Controller

## Remote Controller

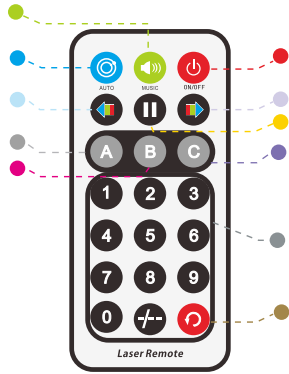

- AUTO Shows
- MUSIC Shows
- Laser NO/OFF
- Color Changing
- Effect Pause
- Mirror Func
- SOUND Sensitivity
- Fixed Pattern(32)
- Repeat playing

| Button | Function          | Description  |
|--------|-------------------|--|
|        | ON/OFF            | All modes other than the "slave" mode, continue to press "ON/OFF" in the remote control button for 2 seconds, you can enter or exit the remote mode.           |
|        | AUTO              | AUTO Shows   |
|        | MUSIC             | Music control mode, in this mode, if it receives sound signal, the blue LED will twinkling   |
|        | Sound Sensitivity | In the sound mode, press the "B" key in the remote control, then the panel below "1-9" corresponds to the voice sensitivity setting, "9" is the most sensitive |
|        | Color change      | For multi-color products, each time you press the key, will change color.  |
|        | Picture change    | Show pictures or change pictures   |
|        | Fixed pictures    | Choose your favourite pictures from 1 to 32  |
|        | Repeat playing    | Repeat switching the current pattern and the last pattern  |

Note: In remote mode, all controls and settings are automatically saved until reboot, After the reboot, the first time into the remote control mode, the system will run self-propelled state.



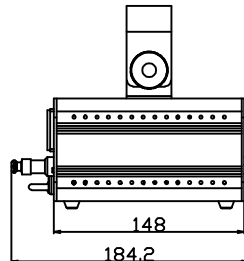
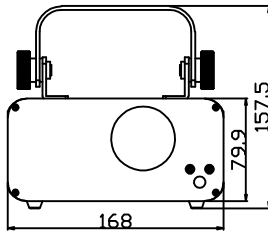

## Mess





# DMX instructions

## DMX Channels Chart

FIT-S(150R RE) FIT-S(50G RE) FIT-S(500B RE) FIT-D(GG RE) FIT-D(BB RE)







| Channel                  | Value   | Function                               |   |
|--------------------------|---------|--|---|
| CH1<br>Mode              | 000-063 | Laser OFF                              |   |
|                          | 064-127 | AUTO                                   |   |
|                          | 128-191 | SOUND                                  |   |
|                          | 192-255 | DMX Model                              |   |
| CH2 pattern              | 000-255 | 32 Laser Patterns                      |   |
| CH3<br>Zooming           | 000-127 | 100%-5% fixed pattern zoomed           |   |
|                          | 128-169 | Zooming IN                             |   |
|                          | 170-209 | Zooming OUT                            |   |
|                          | 210-255 | Alternately Zooming                    |   |
| CH4<br>Y axis<br>rolling | 000-127 | 0 -359 degree fixed Y axis rolled      |    |
|                          | 128-191 | Clockwise rolling                      |   |
|                          | 192-255 | Anticlockwise rolling                  |   |
| CH5<br>X axis<br>rolling | 000-127 | 0 -359 degree fixed X axis rolled      |    |
|                          | 128-191 | Clockwise rolling                      |   |
|                          | 192-255 | Anticlockwise rolling                  |   |
| CH6<br>Z axis<br>rolling | 000-127 | 0 -359 degree fixed Z axis rolled      |    |
|                          | 128-191 | Clockwise rolling                      |   |
|                          | 192-255 | Anticlockwise rolling                  |   |
| CH7<br>X axis<br>mobile  | 000-127 | 128 different fixed position on X axis |    |
|                          | 128-191 | Clockwise moving                       |   |
|                          | 192-255 | Anticlockwise moving                   |   |
| CH8<br>Y axis<br>mobile  | 000-127 | 128 different fixed position on Y axis |  |
|                          | 128-191 | Clockwise moving                       |   |
|                          | 192-255 | Anticlockwise moving                   |   |

## FIT-D(RG RE)

| Channel      | Value   | Faunction                   |   |
|--------------|---------|-----------------------------|---|
| CH9<br>Color | 000-031 | Original preprogramed color |   |
|              | 032-063 | Red                         |  |
|              | 064-095 | Green                       |  |
|              | 096-127 | Red & Green                 |  |
|              | 128-255 | Color Rolling               |   |

































# DMX instructions

FIT-S(RGY RE) FIT-S(RBP RE) FIT-S(GBC RE)

| Channel                  | Value   | Function  |   |
|--------------------------|---------|---|---|
| CH1<br>Mode              | 000-029 | AUT   |   |
|                          | 030-059 | AUT 1   |   |
|                          | 060-089 | AUT 2   |   |
|                          | 090-119 | AUT 3   |   |
|                          | 120-149 | SOU   |   |
|                          | 150-179 | SOU 1   |   |
|                          | 180-209 | SOU 2   |   |
|                          | 210-239 | SOU 3   |   |
|                          | 240-255 | DMX Model   |   |
| CH2 Pattern              | 000-255 | 32 Laser Patterns   |   |
| CH3<br>Color             | 000-024 | Laser OFF  |   |
|                          | 025-049 | Original preprogramed color   |   |
|                          | 050-074 | Color effects 1   |   |
|                          | 075-099 | Color effects 2   |   |
|                          | 100-124 | Color effects 3   |   |
|                          | 125-149 | Color effects 1 To Color effects 2  |   |
|                          | 150-174 | Color effects 2 To Color effects 3  |   |
|                          | 175-199 | Color effects 1 To Color effects 3  |   |
|                          | 200-224 | Color effects 1 To Color effects 2 To Color effects 3                                       |   |
|                          | 225-255 | Color Rolling   |   |
| CH4 Color<br>Roll Speed  | 000-004 | NO rolling  |   |
|                          | 005-255 | Fast to slow  |   |
| CH5<br>Zooming           | 0-127   | 100%-5% fixed pattern zoomed  |   |
|                          | 128-169 | Zooming IN  |   |
|                          | 170-209 | Zooming OUT   |   |
|                          | 210-255 | Alternately Zooming   |   |
| CH6<br>Y axis<br>rolling | 000-127 | 0 -359 degree fixed Y axis rolled   |   |
|                          | 128-191 | Clockwise rolling   |   |
|                          | 192-255 | Anticlockwise rolling   |   |
| CH7<br>X axis<br>rolling | 000-127 | 0 -359 degree fixed X axis rolled   |  |
|                          | 128-191 | Clockwise rolling   |   |
|                          | 192-255 | Anticlockwise rolling   |   |
| CH8<br>Z axis<br>rolling | 000-127 | 0 -359 degree fixed Z axis rolled   |  |
|                          | 128-191 | Clockwise rolling   |   |
|                          | 192-255 | Anticlockwise rolling   |   |
| CH9<br>X axis<br>mobile  | 000-127 | 128 different fixed position on X axis  |  |
|                          | 128-191 | Clockwise moving  |   |
|                          | 192-255 | Anticlockwise moving  |   |
| CH10<br>Y axis<br>mobile | 000-127 | 128 different fixed position on Y axis  |  |
|                          | 128-191 | Clockwise moving  |   |
|                          | 192-255 | Anticlockwise moving  |   |

# Built-in pattern library & Product specification

## Built-in pattern library

| DMX     | Pattern   | DMX     | Pattern   | DMX     | Pattern   | DMX     | Pattern   |
|---------|---|---------|---|---------|---|---------|---|
| 000-007 |  | 064-071 |  | 128-135 |  | 128-135 |  |
| 008-015 |  | 072-079 |  | 138-143 |  | 198-205 |  |
| 016-023 |  | 080-087 |  | 144-151 |  | 206-213 |  |
| 024-031 |  | 088-087 |  | 152-159 |  | 214-221 |  |
| 032-039 |  | 096-103 |  | 160-167 |  | 222-229 |  |
| 040-047 |  | 104-111 |  | 168-175 |  | 230-237 |  |
| 048-055 |  | 112-119 |  | 176-181 |  | 238-245 |  |
| 056-063 |  | 120-127 |  | 182-189 |  | 246-255 |  |

## Product specification

### KML203 – Kam iLink-60G

#### Product specification:

Total Power typical: 60mW

Guaranteed Power 40mW

### KML205 – Kam iLink-750B

#### Product specification:

Total Power typical: 750mW

Guaranteed Power 500mW

| Model          | FIT-S(R)<br>FIT-S(G) FIT-S(B)   | FIT-S(RGY)      | FIT-S(RBP) | FIT-S(GBC) | FIT-D(RG)      | FIT-D(G)<br>FIT-D(B) |
|----------------|---------------------------------|-----------------|------------|------------|----------------|----------------------|
| Red LD 650nm   | 150mw                           | 150mw           | 150mw      |            | 150mw          |                      |
| Green LD 515nm | 50mw                            | 50mw            |            | 50mw       | 50mw           | 100mw                |
| Blue LD 450nm  | <b>500</b> mw                   |                 | 100mw      | 100mw      |                | <b>500</b> mw        |
| Laser level    | Class 3B Laser                  |                 |            |            |                |                      |
| Mess           | 168x148x79.9mm                  |                 |            |            |                |                      |
| Weight         | 1.55kg                          |                 |            |            |                |                      |
| Range          | 100-240V 50/60Hz                |                 |            |            |                |                      |
| Fuse           | 250V 1 A Slow Blow (20mm Glass) |                 |            |            |                |                      |
| Consumption    | 15W                             |                 |            |            | 20W            |                      |
| Channel Range  | 1-19                            | 1-10            |            |            | 1-9            | 1-8                  |
| AUTO           | One show AUTO                   | Four show AUTO  |            |            | One show AUTO  |                      |
| SOUND          | One show SOUND                  | Four show SOUND |            |            | One show SOUND |                      |