



Panasonic SC-HTB490 Home Theater Audio System Instruction Manual

Home » [Panasonic](#) » Panasonic SC-HTB490 Home Theater Audio System Instruction Manual 

Panasonic[®]

**Basic Operating Instructions Home Theater Audio System
Model No. SC-HTB490**



Thank you for purchasing this product.
For optimum performance and safety, please read these instructions carefully.
Please keep this manual for future reference.
Your system and the illustrations can look different.

This manual contains basic information. Visit the website below for detailed instructions.

https://panasonic.jp/support/global/cs/audio/oi/sc_htb490/



https://panasonic.jp/support/global/cs/audio/oi/sc_htb490/

“EB” indicates the United Kingdom model.



Manufactured by: Panasonic Corporation
Kadoma, Osaka, Japan

Authorized Representative in Europe: Panasonic Marketing Europe GmbH
Panasonic Testing Centre
Winsbergring 15, 22525 Hamburg, Germany

Panasonic Corporation

Web Site: <http://www.panasonic.com>

© Panasonic Corporation 2021



TQBJ2331

L1220CH1021

72-H490EB-QSGB1

Contents [[hide](#)]

- [1 Safety precautions](#)
- [2 Caution for AC mains lead](#)
- [3 Sales and Support Information](#)
- [4 Supplied items](#)
- [5 Preparing the remote control](#)
- [6 Making the connections](#)
- [7 Connecting the AC mains lead](#)
- [8 Overview of controls](#)
- [9 Bluetooth®](#)
- [10 Connecting a USB device](#)
- [11 Basic control](#)
- [12 Troubleshooting](#)
- [13 Panasonic Warranty](#)
- [14 File Downloads](#)
- [15 References](#)
- [16 Related Manuals](#)

Safety precautions

WARNING

Unit

- To reduce the risk of fire, electric shock, or product
- Do not expose this unit to rain, moisture, dripping or
- Do not place objects filled with liquids, such as vases, on this
- Use the recommended accessories.
- Do not remove covers.
- Do not repair this unit by yourself. Refer servicing to qualified service personnel.
- To prevent injury, this unit must be securely attached to the wall in accordance with the installation instructions.

AC mains lead

- To reduce the risk of fire, electric shock, or product damage,
- Ensure that the power supply voltage corresponds to the voltage printed on this
- Insert the mains plug fully into the socket outlet.
- Do not pull, bend, or place heavy items on the
- Do not handle the plug with wet hands.
- Fluid onto the mains plug body when disconnecting the
- Do not use a damaged mains plug or socket outlet

Small objects

- Keep the screws and insulation sheet (battery) out of reach of children to prevent swallowing.

Button-type battery (Lithium battery)

- Risk of fire, explosion and burns. Do not recharge, heat above 60°C or incinerate.



WARNING

DO NOT INGEST THE BATTERY. CHEMICAL BURN HAZARD

This remote control contains a coin/button cell battery. If the coin/button cell battery is swallowed, it can cause severe internal burns in just 2 hours and can lead to death.

Keep new and used batteries away from children. If the battery compartment does not close securely, stop using the remote control and keep it away from children. If you think batteries might have been swallowed or placed inside any part of the body, seek immediate medical attention.

CAUTION

Unit

- To reduce the risk of fire, electric shock or product damage,
- Do not install or place this unit in a bookcase, built-in cabinet or in another confined space. Ensure this unit is

well ventilated.

- Do not obstruct this unit's ventilation openings with newspapers, tablecloths, curtains, and similar items.
- Do not place sources of naked flames, such as lighted candles, on this unit.
- This unit is intended for use in moderate climates.
- This unit may receive radio interference caused by mobile telephones during use. If such interference occurs, please increase the separation between this unit and the mobile.
- Set the unit up on an even surface away from direct high temperatures, high humidity, and excessive vibration.
- This system might get warm after prolonged usage. This is Do not be alarming.

AC mains lead

- The mains plug is the disconnecting device. Install this unit so that the mains plug can be unplugged from the socket-outlet immediately.

Button-type battery (Lithium battery)

- The danger of explosion if the battery is incorrectly replaced. Replace only with the type recommended by the manufacturer.
- When disposing of the batteries, please contact your local authorities or dealer and ask for the correct method of disposal.
- Do not heat or expose to flame.
- Do not leave the battery(ies) in a car exposed to direct sunlight for a long period of time with doors and windows closed.
- Insert with poles aligned.
- Remove the battery if you do not use the remote control for a long period of time. Keep in a cool, dark place.

The symbols on this product (including the accessories) represent the following:

~ AC



Class II equipment (The construction of the product is double-insulated.)

I ON



Standby

Caution for AC mains lead

(For the AC mains plug of three pins)

For your safety, please read the following text carefully.

This appliance is supplied with a molded three-pin mains plug for your safety and convenience. A 5-ampere fuse is fitted in this plug. Should the fuse need to be replaced please ensure that the replacement fuse has a rating of 5-ampere and that it is approved by ASTA or BSI to BS1362.

Check for the ASTA mark or the BSI mark on the body of the fuse.

If the plug contains a removable fuse cover you must ensure that it is refitted when the fuse is replaced. If you lose the fuse cover the plug must not be used until a replacement cover is obtained. A replacement fuse cover can be purchased from your local dealer.

Before use

Remove the connector cover.

How to replace the fuse The location of the fuse differ according to the type of AC mains plug (figures A and B).

Confirm the AC mains plug fitted and follow the instructions below. Illustrations may differ from actual AC mains plug.

1. Open the fuse cover with a screwdriver.

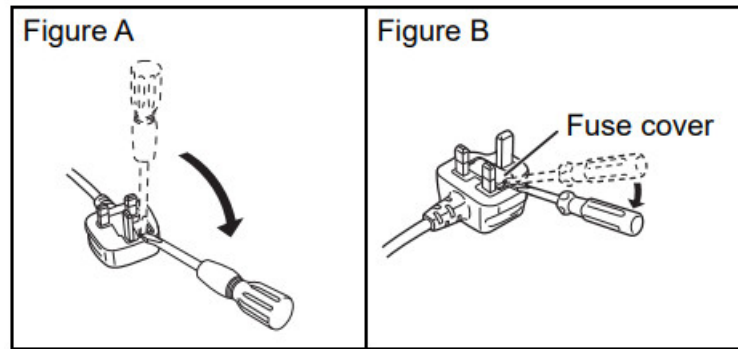

2. Replace the fuse and close or attach the fuse cover.

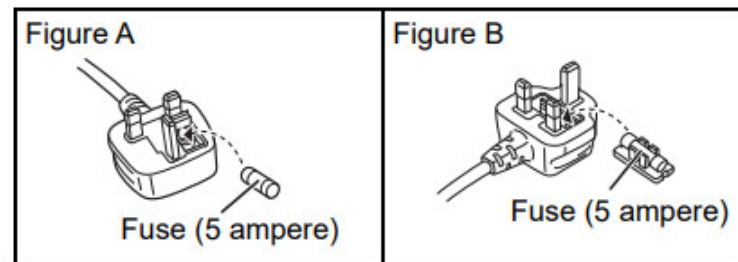

Sales and Support Information

For the United Kingdom and Ireland

Customer Communications Centre

- For customers within the UK: 0344 844 3899
- For customers within Ireland: 01 289 8333
- Monday — Friday 9:00 am — 5:00 pm (Excluding public holidays).
- For further support on your product, please visit our website: panasonic.co.uk

Direct Sales at Panasonic UK

- Order accessory and consumable items for your product with ease and confidence by phoning our Customer Communications Centre
Monday — Friday 9:00 am — 5:00 pm (Excluding public holidays).
- Or go online through our Internet Accessory ordering application at pas-europe.com.
- Most major credit and debit cards
- All inquiries transactions and distribution facilities are provided directly by Panasonic
- It couldn't be simpler!
- Also available through our Internet is direct shopping for a wide range of finished products. Take a browse on our website for further details.

Licenses

The terms HOW and HDMI High-Definition Multimedia Interface and the HDMI Logo are trademarks or registered trademarks of HDMI Licensing Administrator, Inc. in the United States and other countries.

The Bluetooth® word mark and logos are registered trademarks owned by Bluetooth SIG, Inc. and any use of such marks by Panasonic Corporation is under license. Other trademarks and trade names are those of their respective owners.

Manufactured under license from Dolby Laboratories. Dolby, Dolby Audio, and the double-D symbol are trademarks of Dolby Laboratories Licensing Corporation.

For DTS patents, see <http://patents.dts.com>. Manufactured under license from DTS, Inc. DTS, Digital Surround, and the DTS logo are registered trademarks or trademarks of DTS, Inc. in the United States and other countries.
© 2020 DTS, Inc. ALL RIGHTS RESERVED.



Declaration of Conformity (DoC)

Hereby, "Panasonic Corporation" declares that this product is in compliance with the essential requirements and other relevant provisions of Directive 2014/53/EU.

Customers can download a copy of the original DoC to our RE products from our DoC server:

<http://www.ptc.panasonic.eu>

Contact to Authorised Representative: Panasonic Marketing Europe GmbH, Panasonic Testing Centre, Winsbergring 15, 22525 Hamburg, Germany

Type of wireless	Frequency band
Bluetooth® (Main unit)	2402 - 2480 MHz
2.4 GHz wireless system (Main unit and active subwoofer)	2404 - 2476 MHz

Supplied items

Product numbers are correct as of December 2020. These may be subject to change.

- **1 Main unit (speaker)**
(SU-HTB490)
- **1 Wall mount bracket**
(left) (TEKL057)
- **1 Active subwoofer**
(SB-HWA490)
- **1 Wall mount bracket**
(right) (TEKL058)
- **2 Screws (for wall mount bracket)**
(XYN5+J14FJK)
- **2 AC mains lead**
1.5 m: For the main unit
1.2 m: For active subwoofer
- **For the united kingdom and Ireland.**
1.5 m (TSXA216)
1.2 m (TSXA217)
- **1 Remote control (with a battery)**
(N2QAYC000134)
- **For the united kingdom and Ireland.**
2 Stands (TYL0568)
- **For the united kingdom and Ireland.**
2 Screws (for stands)
(THEC445Z)

Preparing the remote control

Before using for the first time

Remove the insulation sheet.

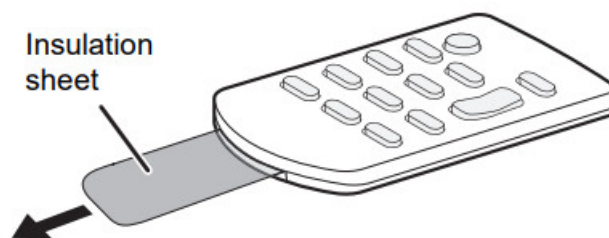

Replacing the battery

Replace with a new battery (CR2025 lithium battery).

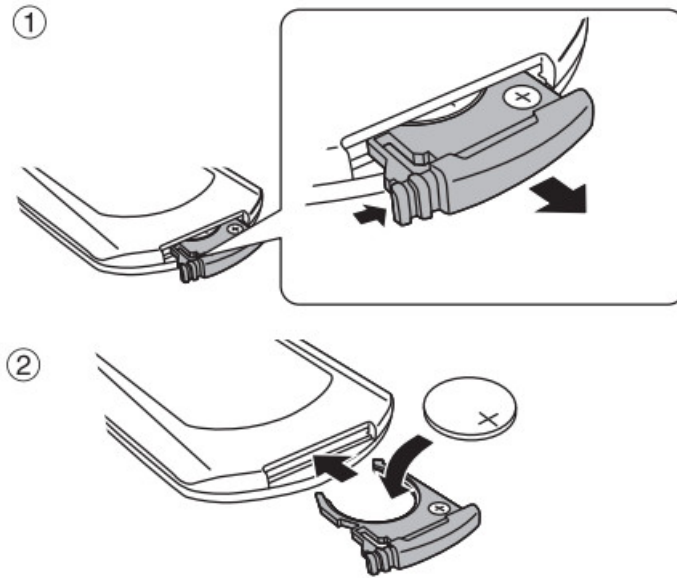

Insert a new battery with the (+) side facing up.

Caution

Avoid the use in the following conditions

- High or low extreme temperatures during use storage or transportation.
- Replacement of a battery with an incorrect type
- Disposal of a battery into fire or a hot oven, or mechanically crushing or cutting of a battery. that can result in an explosion. Extremely high temperature and/or extremely low air pressure can result in an explosion or the leakage of flammable liquid or gas.

Making the connections

Switch off all equipment before connection. Components and cables are sold separately. Connect the AC mains lead only after all the other connections have been made.

Connecting the TV

Connect an ARC compatible TV

Connect to the ARC-compatible terminal of the TV with an ARC-compatible high-speed HDMI cable.

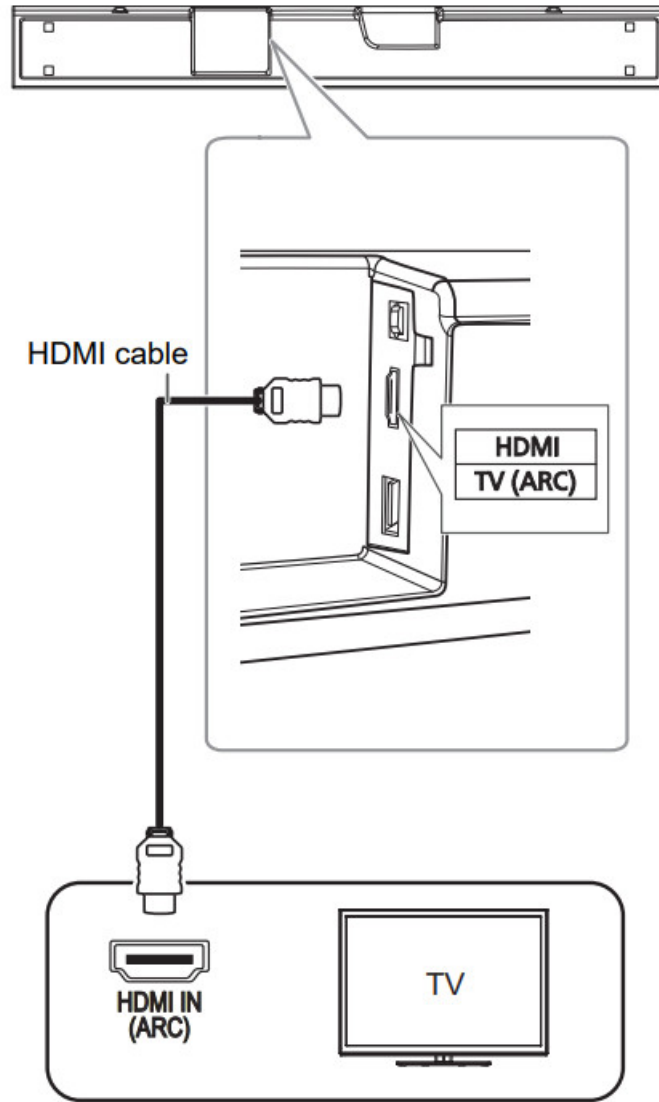

ARC (Audio Return Channel) ARC is an HDMI function that lets you enjoy both sound and TV pictures with one HDMI cable, the optical digital audio cable that is usually required in order to listen to sound from a TV is no longer required.

Connect a non-ARC compatible TV

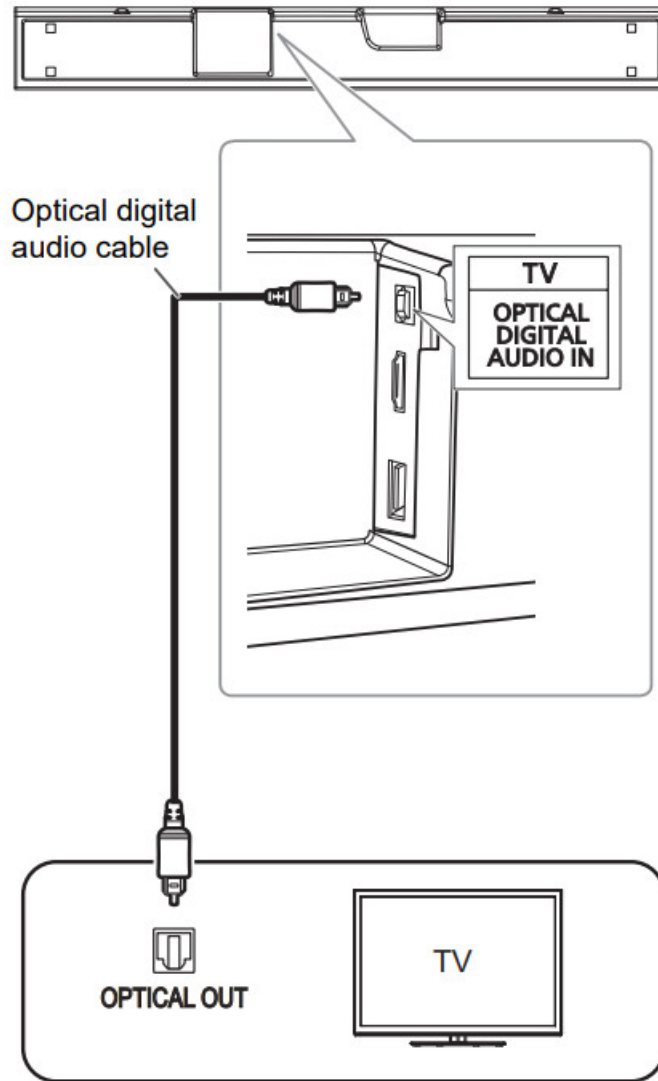

When connecting the optical digital audio cable, observe the orientation and insert the tip correctly into the terminal.

Connecting the AC mains lead

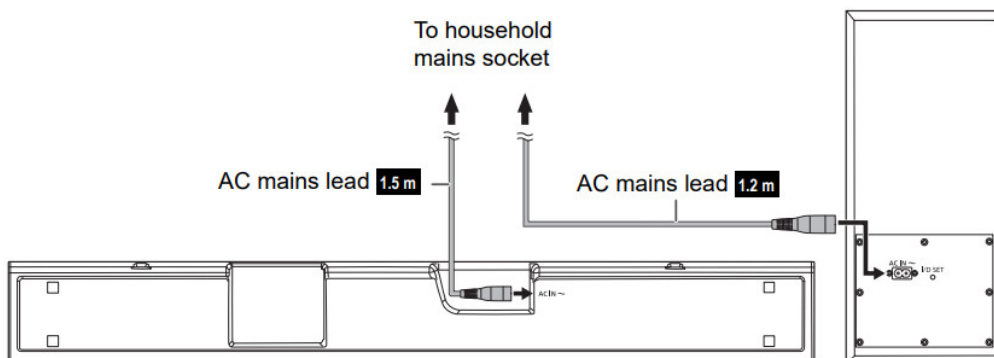

Note: The active subwoofer is in standby condition when the AC mains lead is connected. The primary circuit is always live" as long as the AC mains lead is connected to an electrical outlet.

Overview of controls

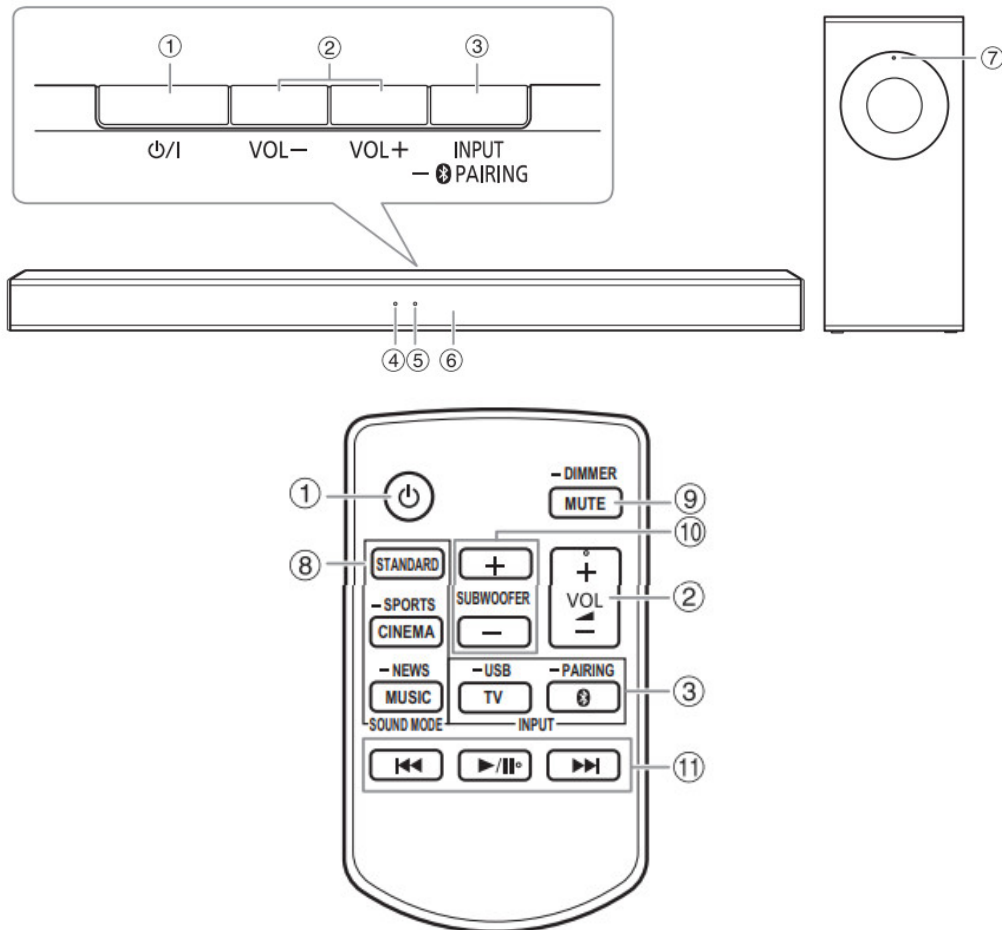

1. Standby/on switch /1 [] Press to switch the unit from on to standby mode or vice versa.
In standby mode, the unit is still consuming a small amount of power.

2. Adjust the volume level

3. Select the input source

On the main unit:



To start Bluetooth® pairing, press and hold
[- PAIRING].

4. Indicator A

The indicator lights up or blinks in various colors depending on the operations performed.

5. Indicator B

The indicator lights up or blinks in various colors depending on the operations performed.

6. Remote control sensor

Point the remote control at the remote control sensor, away from obstacles and within the operation range.

Distance: Within approximately 7 m Angle: Approximately 20° up and down, 30° left and right

7. WIRELESS LINK indicator

8. Select the sound mode

9. Mute the sound

Dim the indicators

10. Select the subwoofer setting
11. USB and Bluetooth® playback control

Play Press [▶/||].

Pause Press [▶/||]. Press again to continue playback.

Skip Press [⏪] or [⏩].

Bluetooth®

Preparation

Switch on the Bluetooth® feature of the device and put the device near the system.

Pairing a device

1. Press and hold [ -PAIRING] until Indicator A blinks fast in blue.
2. Select "SC-HTB490" from the Bluetooth® menu of the device.

Connecting a paired device

1. Press [ -PAIRING].
2. Select "SC-HTB490" from the Bluetooth menu of the device.
3. Start playback on the device.

Note:

When a sound interruption occurs during use with a wireless TV:

- Change the N to use the 5 GHz wireless range, or
- Adjust the main unit to a position with the least interference, such as put it in front of the N instead of below the N.

Connecting a USB device

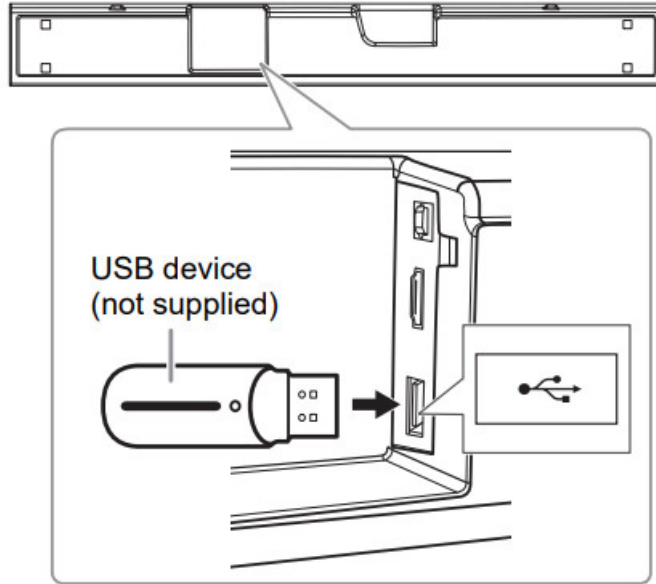

Basic control

Preparation

Switch on the TV and/or connected device.

1. Press  to switch on the system.
2. Select the Input source.

TV: Press [TV].

Bluetooth: Press [ -PAIRING].

USB: Press and hold [-USB].

Alternatively, press [INPUT] on the main unit to select the source



Source	Indicator A
N	lights up in white.
Bluetooth	lights up in blue.
USB	lights up in green.

Troubleshooting

Before requesting service, refer to troubleshooting in “Operating Instructions (PDF format)”. If the problem remains unresolved, consult your dealer for instructions.



For the United Kingdom and Ireland

These symbols indicate the separate collection of waste electrical and electronic equipment or waste batteries.

More detailed information is contained in 'Operating Instructions (PDF format)'.



For Australia and New Zealand

Disposal of Old Equipment and Batteries Only for European Union and countries with recycle systems



These symbols are only valid in the European Union and countries with recycling systems.

If you wish to discard this product, please contact your local authorities or dealer and ask for the correct method of disposal.

Panasonic Warranty

1. Subject to the conditions of this warranty Panasonic or its Authorised Service Centre will perform necessary service on the product, without charge for parts or labor, if in the opinion of Panasonic the product is found to have a manufacturing defect within one (1) year or (12 months) (the warranty period¹) from the date of purchase appearing on your purchase receipt.
2. This warranty only applies to Panasonic products purchased in Australia and sold by Panasonic Australia, its Authorised Distributors or Dealers, and only where the products are used and serviced within Australia or its territories. Warranty cover only applies to the services that are carried out by a Panasonic Authorised Service Centre and only if valid proof of purchase is presented when the warranty service is requested.
3. This warranty only applies if the product has been installed and/or used in accordance with the manufacturer's recommendations (as noted in the operating instructions) under normal use and reasonable care (in the opinion of Panasonic). The warranty does not cover damage, malfunction or failure resulting from use of incorrect voltages, incorrect installation, accident, misuse, neglect, build-up of dirt or dust, abuse, maladjustment of customer controls, mains supply problems, thunderstorm activity, infestation by insects or vermin, tampering or repair by unauthorized persons (including unauthorized alterations), exposure to abnormally corrosive conditions, or any foreign object or matter having entered the product.
4. This warranty does not cover the following items unless the fault or defect existed at the time of purchase:
 - a. Consumable parts
 - b. Cosmetic parts
 - c. Worn or damaged parts
 - d. Information stored on Hard Disk Drives, Optical Discs, USB Devices, SD Cards, Tapes
 - e. DTV reception issues caused by TV Aerial / Cabling / Wall socket(s)
5. Some products may be supplied with Ethernet connection hardware. The warranty is limited on such products and will not cover:
 - a. Internet and or DLNA connection/setup related problems
 - b. Access fees and or charges incurred for internet connection
 - c. Incompatible software or software not specifically stipulated in the product operations manual; and
 - d. Any indirect or consequential costs associated with the incorrect use or misuse of the hardware, its connection to the internet or any other device.
6. To claim warranty service, when required, you should:
 - Contact Panasonic's Customer Care Centre on 132 600 for Service Centre information.

- Confirm the opening and acceptance times with the Authorised Service Centre that you choose.
 - Then send or take the product to a Panasonic Authorised Service Centre together with your proof of purchase receipt.
 - Any freight and insurance costs associated with the transport of the product to and/or from your nearest Authorised Service Centre must be arranged and paid for by
7. The warranties hereby conferred do not extend to, and exclude, any costs associated with the installation, de-installation, or re-installation of a product, including costs related to the mounting, de-mounting or remounting of any screen, (and any other ancillary activities), delivery, handling, freighting, transportation or insurance of the product or any part thereof or replacement of and do not extend to, and exclude, any damage or loss occurring by reason of, during, associated with, or related to such installation, de-installation, re-installation or transit.

Panasonic Authorised Service Centres are located in major metropolitan areas and most regional centres of Australia, however, coverage will vary depending on product. For advice on exact Authorised Service Centre locations for your product, please telephone our Customer Care Centre on 132 600 or visit our website and use the Service Centre Locator. In addition to your rights under this warranty, Panasonic products come with consumer guarantees that cannot be excluded under the Australian Consumer Law. If there is a major failure with the product, you can reject the product and elect to have a refund or to have the product replaced or if you wish you may elect to keep the goods and be compensated for the drop in value of the goods. You are also entitled to have the product repaired or replaced if the product fails to be of acceptable quality and the failure does not amount to a major failure. If there is a major failure in regard to the product which cannot be remedied then you must notify us within a reasonable period by contacting the Panasonic Customer Care Centre. If the failure in the product is not a major failure then Panasonic may choose to repair or replace the product and will do so in a reasonable period of time from receiving notice from you.

THIS WARRANTY CARD AND THE PURCHASE DOCKET (OR SIMILAR PROOF OF PURCHASE) SHOULD BE RETAINED BY THE CUSTOMER AT ALL TIMES

If you require assistance regarding warranty conditions or any other inquiries, please visit the Panasonic Australia website www.panasonic.com.au or contact by phone on 132 600 It phoning In, please ensure you have your operating instructions available.

Panasonic Australia Pty. Limited

ACN 001 592 187 AEN 83 001 592 187



1 Innovation Road. Macquarie Park NSW 2113

www.panasonic.com.au

File Downloads

	<p>Panasonic Instruction Manual SC-HTB490, Home Theater Audio System</p>	<p>Download [optimized] Download</p>
---	--	--

References

-  [Bluetooth® Trademark](#)
-  [Bluetooth® Trademark](#)

Related Manuals

1. [Panasonic SC-PT760/ SC-PT960/ SC-PT954 DVD Home Theater Sound System Operating Instruction](#)
Panasonic SC-PT760/ SC-PT960/ SC-PT954 DVD Home Theater Sound System Operating...
2. [Panasonic SC-PT160 DVD Home Theater Sound System Operating Instructions](#) Panasonic SC-PT160 DVD
Home Theater Sound System Operating Instructions –...
3. [JVC TH-S560B Audio Home Theater System Soundbar User Manual](#) TH-S560B Audio Home Theater System
Soundbar TH-S560B Audio Home Theater...
4. [AZATOM Studio Cinemax 2.1 Ch Home Theater System Instruction Manual](#) AZATOM Studio Cinemax 2.1 Ch
Home Theater System Instruction Manual...
5. [Set up home theater audio with HomePod and Apple TV 4K – Apple Support](#) Set up home theater audio with
HomePod and Apple TV...
6. [Panasonic Home Monitoring Camera Homehawk Shelf User Guide](#) Panasonic Home Monitoring Camera
Homehawk Shelf Thank you for purchasing...