

# **EQUINOX**

## **Avalanche Snow Machine**

**User Manual**



**Order code: EQLED358**

### WARNING:

**FOR YOUR OWN SAFETY, PLEASE READ THIS USER MANUAL CAREFULLY BEFORE YOUR INITIAL START-UP!**

- Before your initial start-up, please make sure that there is no damage caused during transportation.
- Should there be any damage, consult your dealer and do not use the equipment.
- To maintain the equipment in good working condition and to ensure safe operation, it is necessary for the user to follow the safety instructions and warning notes written in this manual.



- Please note that damages caused by user modifications to this equipment are not subject to warranty.

**IMPORTANT:** The manufacturer will not accept liability for any resulting damages caused by the non-observance of this manual or any unauthorised modification to the equipment.

- Never let the power cable come into contact with other cables. Handle the power cable and all mains voltage connections with particular caution!
- Never remove warning or informative labels from the unit.
- Do not open the equipment and do not modify the unit.
- Do not switch the equipment on and off in short intervals, as this will reduce the system's life.
- Only use the equipment indoors.
- Do not expose to flammable sources, liquids or gases.
- Always disconnect the power from the mains when equipment is not in use or before cleaning! Only handle the power-cable by the plug. Never pull out the plug by pulling the power-cable.
- Make sure that the available mains supply voltage is 240V AC, 50Hz.
- Make sure that the power cable is never crimped or damaged. Check the equipment and the power cable periodically.
- If the equipment is dropped or damaged, disconnect the mains power supply immediately and have a qualified engineer inspect the equipment before operating again.
- This unit is not intended for fixed installation.
- If the equipment has been exposed to drastic temperature fluctuation (e.g. after transportation), do not connect power or switch it on immediately. The arising condensation might damage the equipment. Leave the equipment switched off until it has reached room temperature.
- If your product fails to function correctly, stop use immediately. Pack the unit securely (preferably in the original packing material), and return it to your Prolight dealer for service.
- Only use fuses of same type and rating.
- Repairs, servicing and power connection must only be carried out by a qualified technician. THIS UNIT CONTAINS NO USER SERVICEABLE PARTS.
- This fixture is for professional use only - it is not designed for or suitable for household use. The product must be installed by a qualified technician in accordance with local territory regulations. The safety of the installation is the responsibility of the installer. The fixture presents risks of severe injury or death due to fire hazards, electric shock and falls.
- **WARRANTY:** One year from date of purchase.

### OPERATING DETERMINATIONS

If this equipment is operated in any other way, than those described in this manual, the product may suffer damage and the warranty becomes void. Incorrect operation may lead to danger e.g: short-circuit, burns and electric shocks etc.

Do not endanger your own safety and the safety of others!

Incorrect installation or use can cause serious damage to people and/or property.

Before filling the unit disconnect the mains. Never fill with hot liquids.

Only use high quality, water based snow fluid recommended by the manufacturer.

Other snow fluids may cause clogging and void the guarantee.

Always make sure there is sufficient snow fluid in the tank. Operating this snow machine without snow fluid will cause damage to the pump.

Operate the unit only after you have familiarised yourself with its functions. Do not permit operation by persons not qualified for operating the unit and always drain the tank and use the original packaging if the unit is to be transported.

### Avalanche Snow Machine

Designed for large events, the Avalanche from Equinox utilises a large, high output fan to project the snow flakes up to 10 metres into the air. Adjustable output, controllable from either the supplied wired remote control or on board DMX. Supplied complete with custom designed flight case for protection during transportation. The robust steel chassis with built in tilt mechanism allows the user to direct the output as required.

- Output volume: 150m<sup>3</sup> per minute (full on)
- Fluid consumption: 540ml/min at 100% (approx.)
- Control: Wired remote control and DMX



Specifications	
Power consumption	1500W (max.)
Power supply	240V, 50Hz
Unit dimensions	830 x 470 x 820mm
Unit weight	28.8kg
Flight case dimensions with wheels	1010 x 880 x 520mm
Flight case dimensions without wheels	890 x 880 x 520mm
Flight case weight	30kg
Total weight	58.8kg
Order code	EQLED358



Flightcase included



Handheld Remote Control included

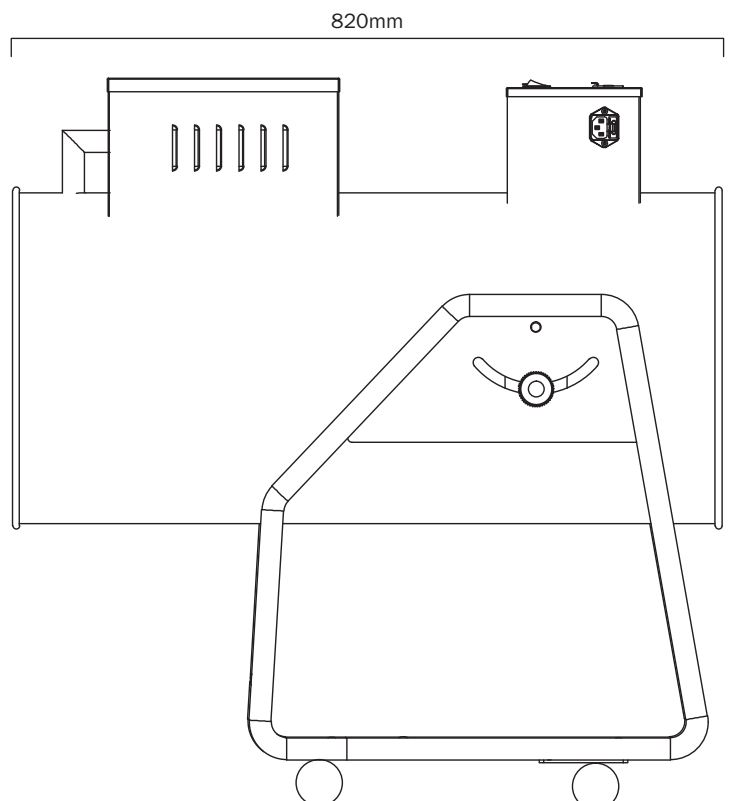
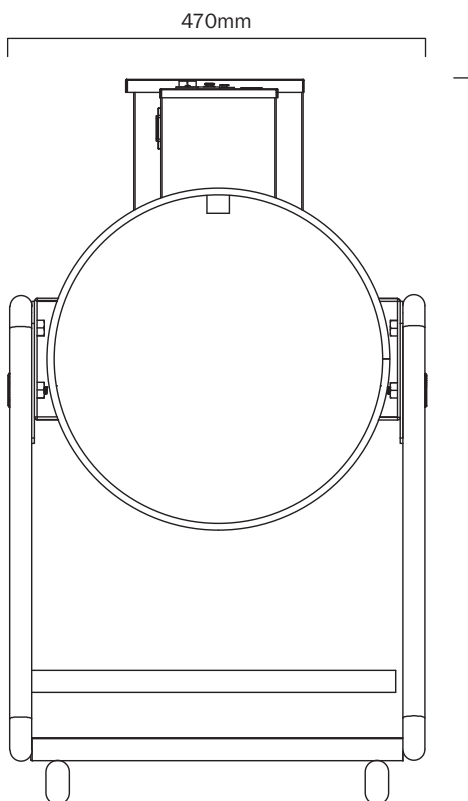

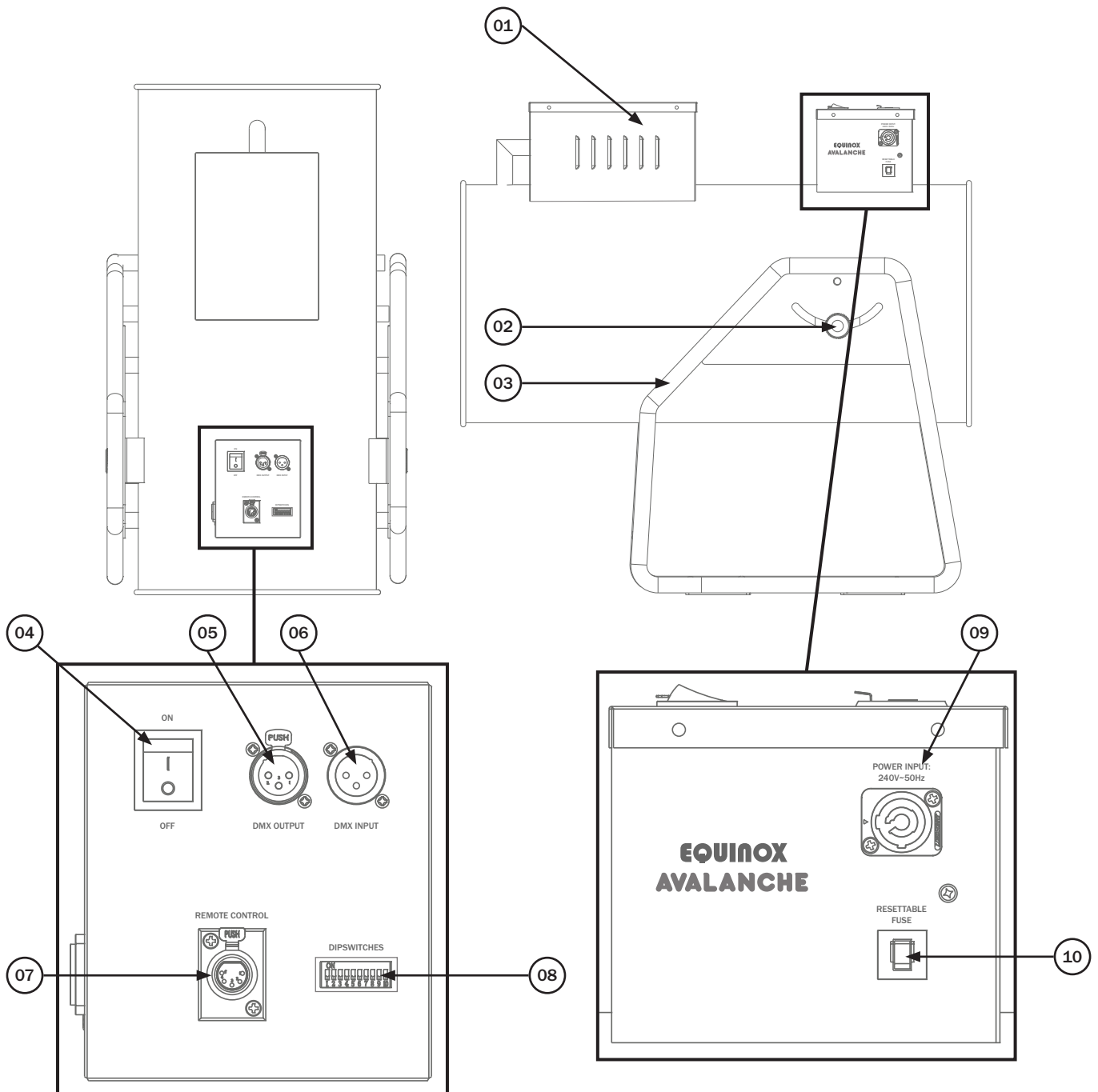

01 - Fluid pipe and intake unit

02 - Bracket adjustment knobs

03 - Bracket

04 - Power switch

05 - 3-Pin XLR output

06 - 3-Pin XLR input

07 - Remote control socket

08 - Dipswitches

09 - Resettable fuse 15A 250V

10 - PowerCON input

In the box:

**1 x fixture, 1 x remote control, 1 x flightcase with wheels, 1 x powerCON cable & 1 x user manual**

### Operation:

Place the unit on a level surface.

Always disconnect it from the mains supply before filling as fluid could be spilled.

Always fill the tank away from the unit to prevent fluid getting inside the main housing.

If fluid should get inside the main housing, disconnect the unit from the mains immediately and consult a technician.

### Installation:

Install the unit in a well-ventilated area. Use in an insufficiently ventilated room can lead to the condensation of the snow fluid. The resulting slippery surface can cause accidents. Keep a minimum distance of 1m around the unit.

Furthermore do not orientate the output aperture directly in the direction of the audience's eyes. In order to create the best effect, there should be a distance between the unit and the audience of at least 5m.

Only install the snow machine on fire resistant, scratch resistant and water resistant surfaces.

This unit is constructed for a free standing installation only. The unit can be used whilst in the base of the flightcase with the lid removed. Make sure all brakes are applied to the flightcase and the unit.

The operator must always make sure that the safety-relating and machine-technical installations are approved by an expert before operation for the first time and after any further changes are made.

The operator has to make sure that the safety-relating and machine-technical installations are approved by a qualified person once a year.

### Important:

Please make sure you connect a substantial fluid source as 5 litres of fluid will only produce a maximum of 10 minutes full on snow output. Do not allow the fluid source to run dry.

To prevent the unit from overheating it is advised after 20 minutes on continuous operation you stop the unit outputting snow for approx. 10 minutes so the unit can cool down.

**At the end of each operation water must be run through the pump to prevent seizure.**



#### **DANGER OF FIRE!**

When installing the unit, make sure there is no highly flammable material (decoration articles etc) within a minimum distance of 1m



#### **DANGER TO LIFE!**

Disconnect from the mains before starting maintenance

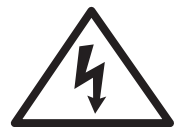

Only use quality snow fluids recommended by your dealer. You must not use substances which are classified as 'DANGEROUS WORKING MATERIALS' or 'FLAMMABLE FLUIDS'.

### Cleaning and maintenance:

We recommend a frequent cleaning of the unit. Please use a soft lint-free and moistened cloth.

Never use alcohol or solvents!

The fluids we recommend are non-hazardous to the environment and can be disposed of via the sewage system.

There are no serviceable parts inside this unit.

Maintenance and service operations are only to be carried out by authorised dealers.

### Breaker reset:

In the event of a power failure, please reset the 15A breaker located below the PowerCON input. If the breaker trips after it has been reset, this usually indicates a component fault. Disconnect the unit from the mains power supply and contact your local dealer for more information.

Should you need any spare parts, only use genuine parts.

If defective, please dispose of the unusable unit in accordance with the current legal regulations.

Should you have any further questions, please contact your dealer.

### Operation:

Connect the unit to a mains power supply via a powerCON cable. Then turn the power switch to ON, the red indication light on the power switch will illuminate.

For manual control simply connect the remote control provided and follow the remote control operation instructions below.

### Remote control operation:

Ensure the remote control switch is off and the output volume rotary knob is turned counter-clockwise until it stops.

Connect the handheld remote control to the main unit via the remote control socket. Once the remote is connected the red power indicator will illuminate.

Press the switch on the handheld remote control to ON, the green in use indicator will illuminate.

When you are ready to disperse snow, turn the output volume rotary knob clockwise to the desired output. To stop the dispersion of snow turn the output volume rotary knob counter-clockwise until it stops.

Care should be taken to ensure the fluid level is maintained and the unit is not allowed to run dry of fluid. Isolate from the mains supply before disconnecting or reconnecting the fluid source.

- 01 - Output volume
- 02 - In use indicator
- 03 - Power indicator
- 04 - ON/OFF switch

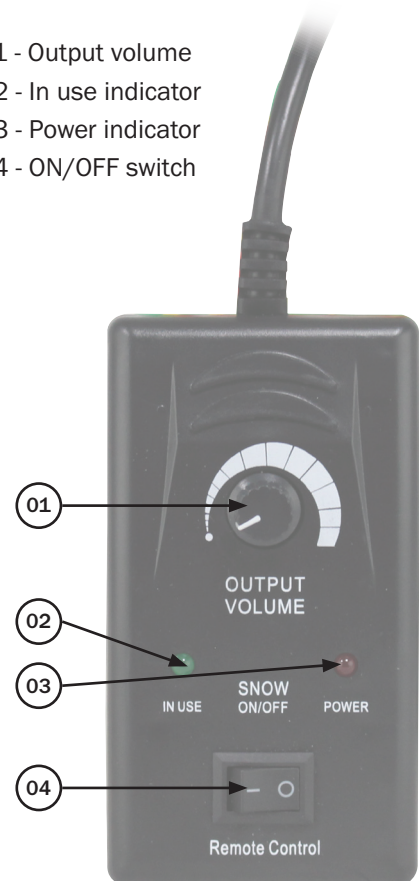

### DMX mode:

Operating in a DMX control mode environment gives the user the greatest flexibility when it comes to customising, controlling or creating a show. DMX addressing is facilitated via the dipswitches on the top of the unit.

### Addressing

Each device occupies 1 channel. To ensure that the control signals are properly directed to each device the fixture requires addressing. This needs to be changed for every fixture by changing the dipswitches as set out in the table below. The starting address is defined as the first channel from which the device will respond to the controller. Please make sure that you do not have any overlapping channels in order to control each fixture correctly and independently from any other fixture on the DMX data link. If two, three, or more devices are addressed similarly, they will work similarly.

### Occupation of the dipswitches:

Dipswitch number	1	2	3	4	5	6	7	8	9
DMX starting address	1	2	4	8	16	32	64	128	256

Fixture 1 - Channel 1	ON	▲							
	OFF		▼	▼	▼	▼	▼	▼	▼

Fixture 2 - Channel 2	ON		▲						
	OFF	▼		▼	▼	▼	▼	▼	▼

Fixture 3 - Channel 3	ON	▲	▲						
	OFF			▼	▼	▼	▼	▼	▼

Fixture 4 - Channel 4	ON			▲					
	OFF	▼	▼		▼	▼	▼	▼	▼

Fixture 5 - Channel 5	ON	▲		▲					
	OFF		▼		▼	▼	▼	▼	▼

### Controlling

After having addressed all devices, you may now start operating these via your controller.

### 1 channel mode

Channel	Value	Function
CH1	000-255	Snow output (0-100%)



## DMX dipswitch quick reference chart

DMX DIPSWITCH SET 0 = OFF 1 = ON					#9	0	0	0	0	0	0	0	0	1	1	1	1	1	1	1		
					#8	0	0	0	0	1	1	1	1	0	0	0	0	1	1	1	1	1
					#7	0	0	1	1	0	0	1	1	0	0	1	1	0	0	1	1	1
					#6	0	1	0	1	0	1	0	1	0	1	0	1	0	1	0	1	0
#1	#2	#3	#4	#5																		
0	0	0	0	0		32	64	96	128	160	192	224	256	288	320	352	384	416	448	480		
1	0	0	0	0		1	33	65	97	129	161	193	225	257	289	321	353	385	417	449	481	
0	1	0	0	0		2	34	66	98	130	162	194	226	258	290	322	354	386	418	450	482	
1	1	0	0	0		3	35	67	99	131	163	195	227	259	291	323	355	387	419	451	483	
0	0	1	0	0		4	36	68	100	132	164	196	228	260	292	324	356	388	420	452	484	
1	0	1	0	0		5	37	69	101	133	165	197	229	261	293	325	357	389	421	453	485	
0	1	1	0	0		6	38	70	102	134	166	198	230	262	294	326	358	390	422	454	486	
1	1	1	0	0		7	39	71	103	135	167	199	231	263	295	327	359	391	423	455	487	
0	0	0	1	0		8	40	72	104	136	168	200	232	264	296	328	360	392	424	456	488	
1	0	0	1	0		9	41	73	105	137	169	201	233	265	297	329	361	393	425	457	489	
0	1	0	1	0		10	42	74	106	138	170	202	234	266	298	330	362	394	426	458	490	
1	1	0	1	0		11	43	75	107	139	171	203	235	267	299	331	363	395	427	459	491	
0	0	1	1	0		12	44	76	108	140	172	204	236	268	300	332	364	396	428	460	492	
1	0	1	1	0		13	45	77	109	141	173	205	237	269	301	333	365	397	429	461	493	
0	1	1	1	0		14	46	78	110	142	174	206	238	270	302	334	366	398	430	462	494	
1	1	1	1	0		15	47	79	111	143	175	207	239	271	303	335	367	399	431	463	495	
0	0	0	0	1		16	48	80	112	144	176	208	240	272	304	336	368	400	432	464	496	
1	0	0	0	1		17	49	81	113	145	177	209	241	273	305	337	369	401	433	465	497	
0	1	0	0	1		18	50	82	114	146	178	210	242	274	306	338	370	402	434	466	498	
1	1	0	0	1		19	51	83	115	147	179	211	243	275	307	339	371	403	435	467	499	
0	0	1	0	1		20	52	84	116	148	180	212	244	276	308	340	372	404	436	468	500	
1	0	1	0	1		21	53	85	117	149	181	213	245	277	309	341	373	405	437	469	501	
0	1	1	0	1		22	54	86	118	150	182	214	246	278	310	342	374	406	438	470	502	
1	1	1	0	1		23	55	87	119	151	183	215	247	279	311	343	375	407	439	471	503	
0	0	0	1	1		24	56	88	120	152	184	216	248	280	312	344	376	408	440	472	504	
1	0	0	1	1		25	57	89	121	153	185	217	249	281	313	345	377	409	441	473	505	
0	1	0	1	1		26	58	90	122	154	186	218	250	282	314	346	378	410	442	474	506	
1	1	0	1	1		27	59	91	123	155	187	219	251	283	315	347	379	411	443	475	507	
0	0	1	1	1		28	60	92	124	156	188	220	252	284	316	348	380	412	444	476	508	
1	0	1	1	1		29	61	93	125	157	189	221	253	285	317	349	381	413	445	477	509	
0	1	1	1	1		30	62	94	126	158	190	222	254	286	318	350	382	414	446	478	510	
1	1	1	1	1		31	63	95	127	159	191	223	255	287	319	351	383	415	447	479	511	

### Setting the DMX address:

The DMX mode enables the use of a universal DMX controller. Each fixture requires a “start address” from 1- 511. A fixture requiring one or more channels for control begins to read the data on the channel indicated by the start address. For example, a fixture that occupies or uses 7 channels of DMX and was addressed to start on DMX channel 100, would read data from channels: 100,101,102,103,104,105 and 106. Choose a start address so that the channels used do not overlap. E.g. the next unit in the chain starts at 107.

### DMX 512:

DMX (Digital Multiplex) is a universal protocol used as a form of communication between intelligent fixtures and controllers. A DMX controller sends DMX data instructions from the controller to the fixture. DMX data is sent as serial data that travels from fixture to fixture via the DATA “IN” and DATA “OUT” XLR terminals located on all DMX fixtures (most controllers only have a data “out” terminal).

### DMX linking:

DMX is a language allowing all makes and models of different manufactures to be linked together and operate from a single controller, as long as all fixtures and the controller are DMX compliant. To ensure proper DMX data transmission, when using several DMX fixtures try to use the shortest cable path possible. The order in which fixtures are connected in a DMX line does not influence the DMX addressing. For example; a fixture assigned to a DMX address of 1 may be placed anywhere in a DMX line, at the beginning, at the end, or anywhere in the middle. When a fixture is assigned a DMX address of 1, the DMX controller knows to send DATA assigned to address 1 to that unit, no matter where it is located in the DMX chain.

### DATA cable (DMX cable) requirements (for DMX operation):

This fixture can be controlled via DMX-512 protocol. The DMX address is set on the back of the unit. Your unit and your DMX controller require a standard 3-pin XLR connector for data input/output, see image below.



Further DMX cables can be purchased from all good sound and lighting suppliers or Pro Light Concepts dealers.

Please quote:

**CABL10 – 2m**

**CABL11 – 5m**

**CABL12 – 10m**

**Note: DMX cable must be daisy chained and cannot be split.**

**Notice:**

Be sure to follow the diagrams below when making your own cables. Do not connect the cables shield conductor to the ground lug or allow the shield conductor to come in contact with the XLRs outer casing. Grounding the shield could cause a short circuit and erratic behaviour.

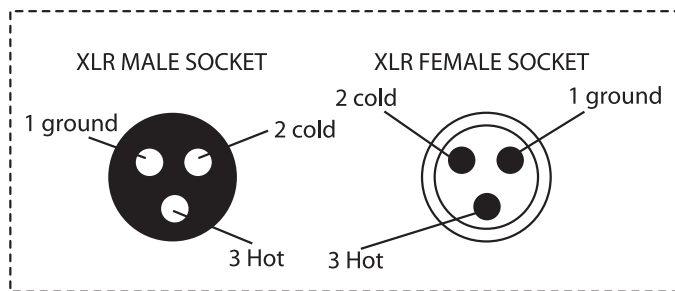
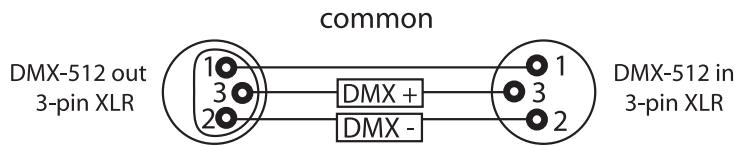

XLR Pin Configuration
Pin 1 = Ground
Pin 2 = Negative
Pin 3 = Positive

**Special note:**

**Line termination:**

When longer runs of cable are used, you may need to use a terminator on the last unit to avoid erratic behaviour.

**Using a cable terminator will decrease the possibilities of erratic behaviour.**

**(3-pin - Order ref: CABL90, 5-pin - Order ref: CABL89)**

Termination reduces signal transmission problems and interference. It is always advisable to connect a DMX terminal, (resistance 120 Ohm 1/4 W) between pin 2 (DMX-) and pin 3 (DMX+) of the last fixture.

**5-pin XLR DMX connectors:**

Some manufactures use 5-pin XLR connectors for data transmission in place of 3-pin. 5-pin XLR fixtures may be implemented in a 3-pin XLR DMX line. When inserting standard 5-pin XLR connectors in to a 3-pin line a cable adaptor must be used. The diagram below details the correct cable conversion.

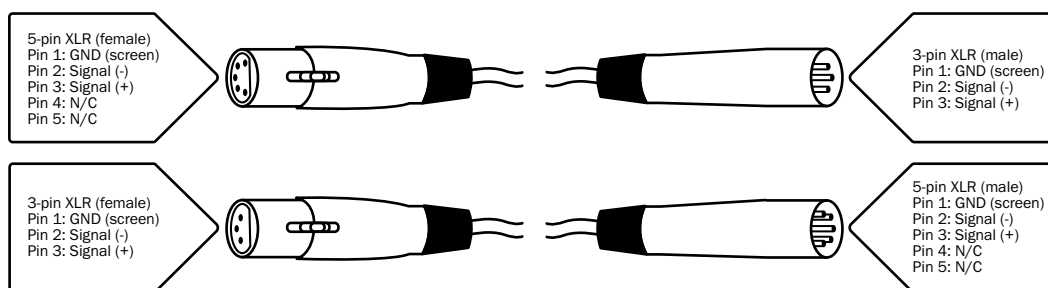



### ***Correct Disposal of this Product (Waste Electrical & Electronic Equipment)***

**(Applicable in the European Union and other European countries  
with separate collection systems)**

This marking shown on the product or its literature, indicates that it should not be disposed of with other household wastes at the end of its working life. To prevent possible harm to the environment or human health from uncontrolled waste disposal, please separate this from other types of wastes and recycle it responsibly to promote the sustainable reuse of material resources.

Household users should contact either the retailer where they purchased this product, or their local government office, for details of where and how they can take this item for environmentally safe recycling.

Business users should contact their supplier and check the terms and conditions of the purchase contract. This product should not be mixed with other commercial wastes for disposal.

