



0230-0378A

PO BOX 4394  
SANTA ROSA, CA  
95402 USA

P (707) 525-9941  
F (707) 575-7046  
EMGPICKUPS.COM

## INSTALLATION INFORMATION EMG MODEL: JMASTER\* SET

### SPECIFICATIONS:

Logo Color  
Magnet Type  
Resonant Frequency (kHz)  
Output Voltage (String)  
Output Voltage (Strum)  
Output Noise (dBV)  
Output Impedance (kΩ)  
Current @9V (Microamps)  
Battery Life (Hours)<sup>†</sup>  
Maximum Supply (Volts DC)

### MODEL:

JMASTER  
Gold  
Alnico V  
3.15  
0.50  
0.80  
-120  
3.16  
350  
715  
27

<sup>†</sup>estimate for two pickups powered by a single 9V, 500mAh battery

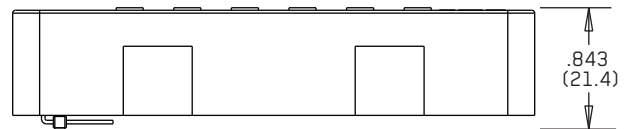
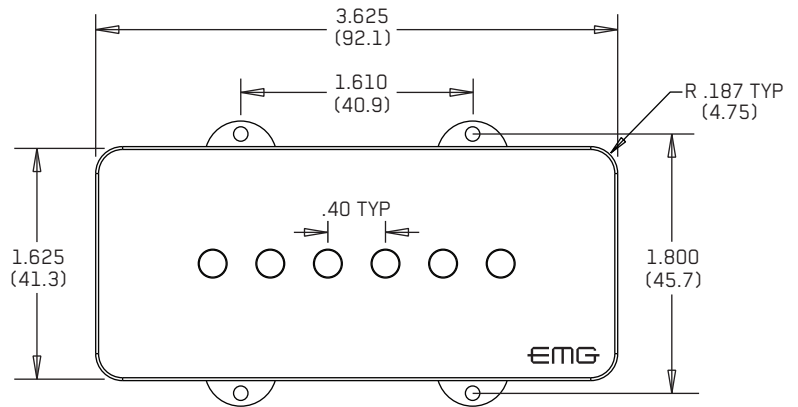

### INSTALLATION NOTES:

The JMASTER\* Set is an active pickup option for Jazzmaster\*\* style guitars. The contents of this set allow for a basic control scheme consisting of master volume, master tone, and a three-position toggle switch (not included). **The unique upper horn controls (i.e. rhythm circuit) found on many Jazzmaster style guitars will NOT be compatible with the EMG JMASTER Pickups, and should be removed or disconnected when installing the JMASTER Set.** If you'd like to add a robust active EQ section to your instrument, please consider the EMG JMASTER SYSTEM which is available as a pre-loaded pickguard. The standalone JMASTER Set is intended for more basic setups and/or instruments which lack sufficient cavity space for upper horn controls. Please verify that your instrument's pickguard can accommodate the JMASTER Pickups before installation.

### INCLUDED WITH EACH SET:

1 VOLUME CONTROL (25K)  
1 TONE CONTROL (25K)

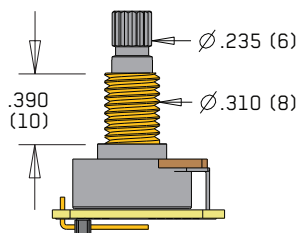

ADJUSTMENT SCREWS (x12)

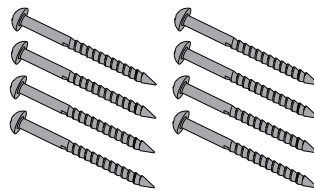

PICKUP CABLE 15" (38cm)



PICKUP CABLE 11" (28cm)



2 CONNECT CABLES 5.5" (14cm)



OUTPUT CABLE 6" (15cm)



BATTERY CABLE 7" (18cm)

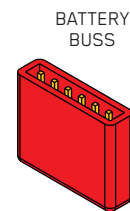

STEREO OUTPUT JACK

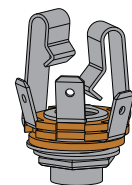

2 PICKUP IN/ OUT BATTERY BUSS (B245)

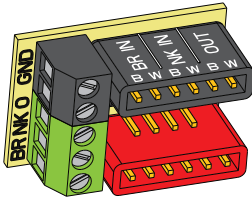

\*JMASTER is a registered trademark of EMG, Inc.

\*\*JAZZMASTER is a trademark of Fender Musical Instruments Corporation

### WARRANTY

All EMG Pickups and accessories are warranted for a period of two years. This warranty does not cover failure due to improper installation, abuse or damage. If upon examination the pickup is determined to be defective, a replacement will be made. Warranty replacement products are covered by this same warranty. This warranty covers only those pickups and accessories sold by authorized EMG Dealers. This warranty is not transferable.

**General Notes:**

- Every attempt has been made to make this a solderless installation. There are some instances where this is not possible;
- 1) If your instrument uses a long panel output jack and you had passive pickups, you will need a new stereo output jack. The Switchcraft 152B is recommended. Soldering to the new jack will be required, refer to Diagram #6.
  - 2) If your instrument has a battery holder installed, soldering may be required to splice its wires to the EMG battery cable. Refer to Diagram #8.
  - 3) Instruments with two pickups may need soldering to the selection switch for some installations.

Before restringing your guitar, it's helpful to check the function of your pickups and controls by performing a "tap test" while plugged into your amplifier set to a low volume. Tap gently on the pickups with a small screwdriver to confirm your pickups are working and that your wiring harness has been properly connected.

Direct mounting your pickups will require placing hard foam beneath each pickup. Many instruments will already have foam underneath the stock pickups, but you may also cut a piece from the packaging foam that comes with your EMG Pickups.

**Installation (Two Pickup Guitars with Selection Switch):**

Guitars with two pickups and a selection switch will use the EMG B245 Pickup Buss as shown in Diagram #2. Find a place to mount the Buss in the control cavity before starting. Then, after the cables are routed use the velcro to mount it securely.

**2 Pickups / Toggle Select Switch / Master Volume and Tone**

Refer to Diagrams #1, #2, and #3

- 1) Install the pickups and route the pickup cables to the control cavity. If the cables are too long, wind up the excess and tuck it inside the cavity.
- 2) Mount the Volume and Tone controls onto the body or pickguard. Plug both pickup cables into the B245 Pickup Buss (BLACK Shroud) as shown. Refer to diagram #2, Bridge Pickup to position 1 and Neck Pickup to position 2
- 3) Plug a connect cable from the Pickup Buss (position 3) to the Master Volume control as shown in Diagram #3
- 4) Plug a connect cable from the Master Volume to the Master Tone as shown.
- 5) Strip the insulation from the switch wires and Insert them into the GREEN Terminal Block and tighten the screws with a small screwdriver. The Bridge pickup goes to the BR Terminal The Neck pickup goes to the NK Terminal The Output of the switch goes to the O Terminal If there is a ground wire coming from the switch, insert it into one of the black GND terminals on the block. If using a solderless EMG 3-way toggle, refer to Diagram #5.
- 6) Plug the output cable onto the Master Tone control and connect the output wires to the output jack by pushing the connectors on as shown. WHITE wire onto the TIP (T) contact, BLACK wire onto the SLEEVE (S) contact BLACK Battery Negative wire onto the RING (R) contact.

**\*\*\*\*Tips and Tricks\*\*\*\* Start your installation by:**

- 1) Determine which type output jack your instrument has. A Stereo 12B type is Included, but if you have a long panel jack a SwitchCraft 152B Long Panel Jack will be required.
- 2) Remove the strings, remove any existing Pickups and controls (remember the order and function of each control)
- 3) Determine a good spot for the Pickup Buss and make sure the cable or wires from the selection switch will reach the Buss
- 4) Install the EMG Volume and Tone Controls and tighten them in
- 5) Then install the pickups keeping any excess cable under the pickup rather than in the control cavity.
- 6) **IMPORTANT: EMG Active pickups do not require a string ground wire! DO NOT reconnect the string ground, it is unnecessary and may pose a shock hazard if using a vintage amplifier.**

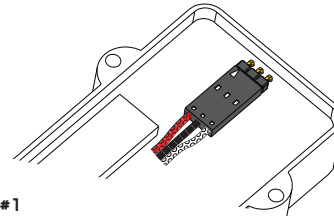

**Diagram #1**  
Insert the plug onto the 3 pin header of the pickup as shown above. Note the orientation arrow.

- 7) Plug the RED wires of the pickups onto the V+ Buss (RED Shroud) along with the RED wire of the battery clip. Extra pins on the V+ Buss are for EMG Accessories.
- 8) Wrap the battery in a piece of insulating foam and place it securely in the control cavity.
- 9) Before restringing your instrument, perform a "tap test" as described above to check that your setup performs as expected.

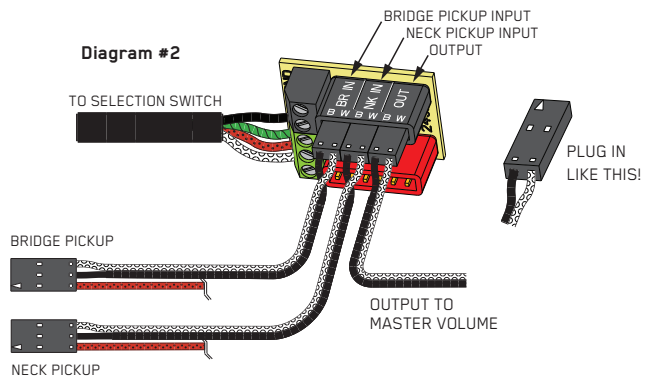

**Diagram #3**

2 Pickups  
Toggle Style Select Switch  
Master Volume & Master Tone

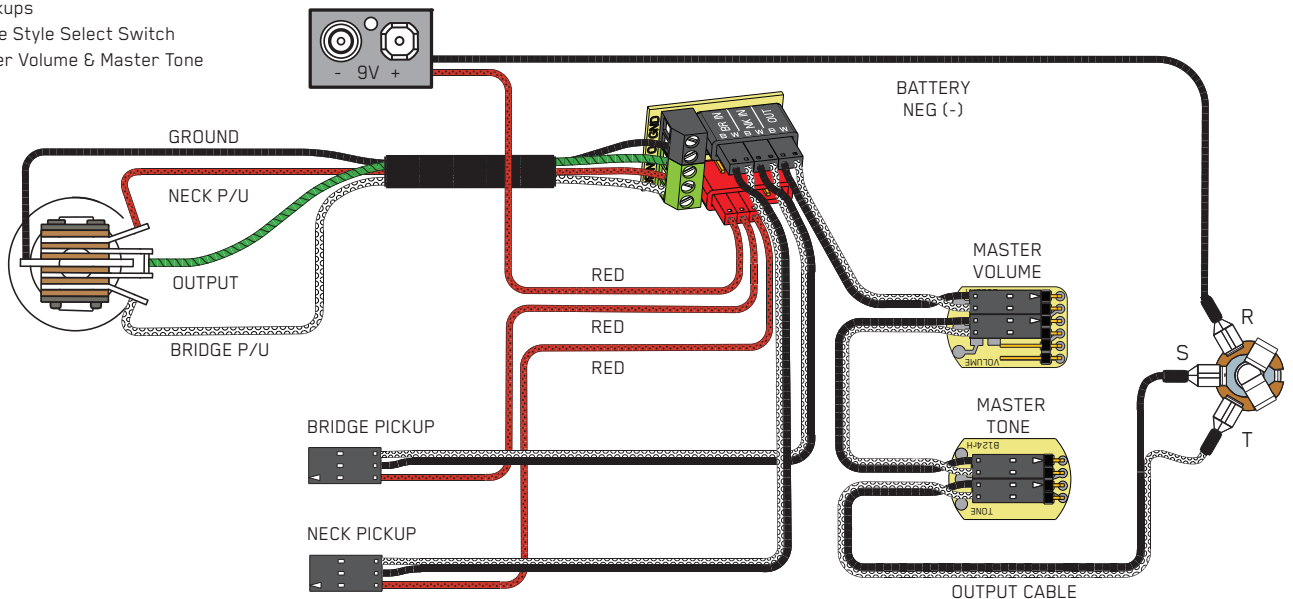

## 2 Pickups / Toggle Select Switch / 2 Volumes (No Tone Control)

Note: This configuration utilizes a second 25K volume control that is **not** included in the JMASTER Set. Additional solderless controls are available at [emgpickups.com](http://emgpickups.com)

Refer to Diagram #4

- 1) Install the pickups and route the pickup cables to the control cavity.  
If the cables are too long, wind up the excess and keep it under the pickup.
- 2) Mount the Volume controls into the body or pickguard.  
Plug both pickup cables onto the Volume controls as shown.  
Plug a connect cable from the Bridge Volume control to the Pickup Buss (Position 1)  
Plug a connect cable from the Neck Volume control to the Pickup Buss (Position 2)
- 3) Strip the insulation from the switch wires and insert them into the GREEN Terminal Block and tighten the screws with a small screwdriver.  
The Bridge Pickup goes to the BR Terminal  
The Neck Pickup goes to the NK Terminal  
The Output of the switch goes to the O Terminal  
If there is a ground wire coming from the switch, insert it into one of the black GND terminals on the block.  
If using a solderless EMG 3-way toggle, refer to Diagram #5.
- 4) Plug the output into the the Pickup Buss (Position 3) and connect the wires to the output jack by pushing the connectors on as shown.  
WHITE wire onto the TIP (T) contact,  
BLACK wire onto the SLEEVE (S) contact  
BLACK Battery Negative wire onto the RING (R) contact.
- 5) Plug the RED Wires of the pickups onto the V+ Buss (RED Shroud) along with the RED of the battery clip. Extra pins are for EMG Accessories.
- 6) Wrap the battery in a piece of insulating foam and place it securely in the control cavity.
- 7) Before restringing your instrument, perform a "tap test" as previously described to check that your setup performs as expected.

**Diagram #4**

2 Pickups  
Toggle Style Switch  
2 Volumes (Dependent)

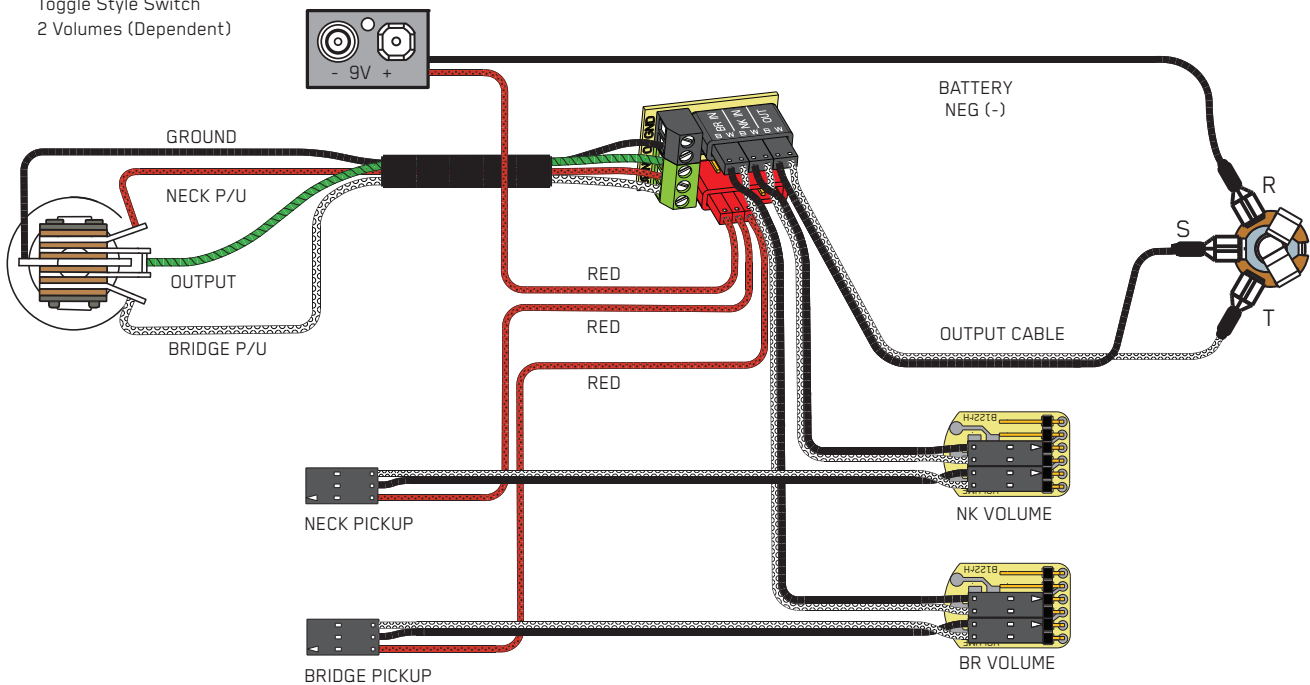
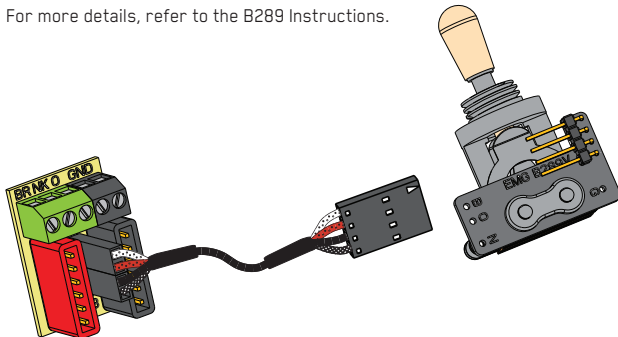

**Diagram #5**

### Connecting to the B289 3-Position Toggle:

Install the 4 pin Connector housing on the switch as shown in the diagram below. Install both of the 2 pin connectors on to the 4 pin connector between the black and red housings as shown. The black and green terminal blocks will not be used for the switch.

For more details, refer to the B289 Instructions.

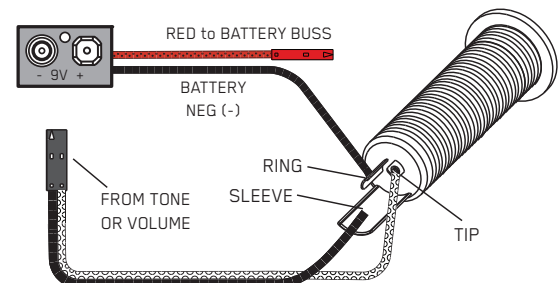

**Diagram #6**

### Soldering to the 152B Panel Jack:

If your instrument has a long barrel jack like the one below, you will need to solder the output cable and battery clip as shown.

Ground (Black) to the Sleeve  
Signal (White) to the Tip  
Battery Negative (Black) to the Ring



**2 Pickups / Toggle Select Switch / Master Volume / Active Accessory (SPC, EXG, VLPF, etc.)**

Note: This configuration utilizes an active accessory that is **not** included in the JMASTER Set.  
 Additional solderless controls are available at [emgpickups.com](http://emgpickups.com)

Refer to Diagram #7

- 1) Install the pickups and route the pickup cables to the control cavity.  
 If the cables are too long, wind up the excess and tuck it inside the cavity
- 2) Mount the Volume and EMG Active Accessory onto the body or pickguard.  
 Plug both pickup cables into the B245 Pickup Buss (BLACK Shroud) as shown.  
 Refer to diagram #2, Bridge Pickup to Position 1 and Neck Pickup to Position 2
- 3) Strip the insulation from the switch wires and Insert them into the GREEN Terminal Block and tighten the screws with a small screwdriver.  
 The Bridge pickup goes to the BR Terminal  
 The Neck pickup goes to the NK Terminal  
 The Output of the switch goes to the O Terminal  
 If there is a ground wire coming from the switch, insert it into one of the black GND terminals on the block.  
 If using a solderless EMG 3-way toggle, refer to Diagram #5.

- 4) Plug a connect cable from the Pickup Buss (Position 3) to the Input of the Active Accessory control as shown in the diagram below.

*Note the orientation of the connect cable at the Input; This "reversed" connection method is common to nearly all EMG Active Accessories like the SPC, EXG, RPC, Afterburner, and more.*

- 5) Plug a connect cable from the Output of the Active Accessory to the Master Volume as shown.
- 6) Plug the output cable onto the Master Volume control and connect the output wires to the output jack by pushing the connectors on as shown.  
 WHITE wire onto the TIP (T) contact,  
 BLACK wire onto the SLEEVE (S) contact  
 BLACK Battery Negative wire onto the RING (R) contact.
- 7) Plug the RED wires of the pickups onto the V+ Buss (RED Shroud) along with the RED wire of the battery clip and the EMG Active Accessory.
- 8) Wrap the battery in a piece of insulating foam and place it securely in the control cavity.
- 9) Before restringing your instrument, perform a "tap test" as previously described to check that your setup performs as expected.

**Diagram #7**

2 Pickups  
 Toggle Style Select Switch  
 Master Volume & Active Accessory

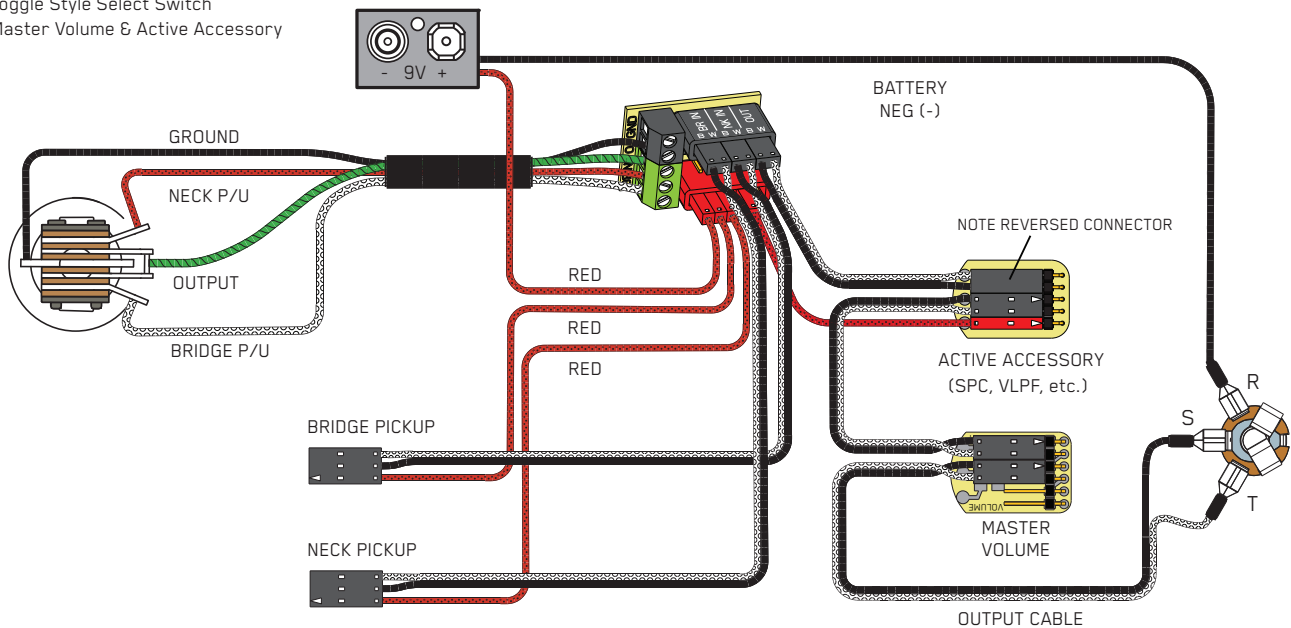

**If the instrument has a Battery Holder:**

If your instrument has a 9 or 18 Volt battery holder you can still use the EMG Connectors to supply power to the pickups. Simply cut and strip the wires from the battery clip provided. Twist the wires together and use the shrink tubing included to cover the connections. Soldering the wires is the preferred.

**Diagram #8**

